

★
T. O. 12R2-2ART13-2

HANDBOOK
MAINTENANCE INSTRUCTIONS

**RADIO TRANSMITTING SET
AN/ART-13A**

THIS PUBLICATION REPLACES T. O. 12R2-2ART13-2 (FORMERLY 16-30ART13-4)
DATED 8 MARCH 1949.

PUBLISHED UNDER AUTHORITY OF THE SECRETARY OF THE AIR FORCE

T. O. 12R2-2ART13-2

Reproduction for non-military use of the information or illustrations contained in this publication is not permitted without specific approval of the issuing service (BuAer or USAF). The policy for use of Classified Publications is established for the Air Force in AFR 205-1 and for the Navy in Navy Regulations, Article 1509.

LIST OF REVISED PAGES ISSUED

INSERT LATEST REVISED PAGES. DESTROY SUPERSEDED PAGES.

NOTE: The portion of the text affected by the current revision is indicated by a vertical line in the outer margins of the page.

* The asterisk indicates pages revised, added or deleted by the current revision.

ADDITIONAL COPIES OF THIS PUBLICATION MAY BE OBTAINED AS FOLLOWS:

USAF ACTIVITIES.—In accordance with Technical Order No. 00-5-2.
NAVAL ACTIVITIES.—Use Publications and Forms Order Blank (NavAer 2126) and submit to the nearest publications supply point listed below: NAS, Alameda, Calif.; NAS, Jacksonville, Fla.; NAS, Norfolk, Va.; NAS, San Diego, Calif.; NAS, Seattle, Wash.; NASD, ASO, Guam; NASD, Philadelphia, Pa.
For listing of available publications see Naval Aeronautic Publications Index (NavAer 00-500).

USAF

TABLE OF CONTENTS

<i>Section</i>	<i>Page</i>
Safety Notice	ix
Important Notice	ix
I. GENERAL DESCRIPTION	1-1
1. Equipment Supplied	1-1
2. Equipment Required but Not Supplied	1-3
3. General Description of Equipment	1-3
<i>a.</i> Transmitters	1-3
<i>b.</i> Dynamotor Unit	1-6
<i>c.</i> Control Units	1-7
<i>d.</i> Control Panel	1-8
<i>e.</i> Antenna Loading Unit	1-8
<i>f.</i> Antenna Shunt Capacitor	1-9
<i>g.</i> Similar Equipment	1-10
4. Interconnection of Radio Transmitting Set AN/ART-13A with Radio Receiving Set AN/ARR-11 to Form Complete Radio Set AN/ARC-8	1-10
5. Interchangeability of Major Units	1-10
6. Abbreviations	1-11—2-1
7. Symbol Designations	1-11—2-1
II. INSTALLATION AND ADJUSTMENT	1-11—2-1
1. Uncrating	1-11—2-1
<i>a.</i> Transmitter	1-11—2-1
<i>b.</i> Dynamotor Crate	1-11—2-1
<i>c.</i> Control Unit	1-11—2-1
<i>d.</i> Antenna Loading Unit	1-11—2-1
<i>e.</i> Antenna Shunt Capacitor	1-11—2-1
2. Preparation for Installation	1-11—2-1
<i>a.</i> Mechanical Inspection	1-11—2-1
<i>b.</i> Bench Test	2-3
3. Installation	2-7
<i>a.</i> Transmitter	2-7
<i>b.</i> Dynamotor Unit	2-7
<i>c.</i> Antenna Loading Unit	2-8
<i>d.</i> Control Unit	2-9
<i>e.</i> Control Panel	2-9
<i>f.</i> Antenna Shunt Capacitor and Switch	2-9
<i>g.</i> Oscillator O-17/ART-13A and Panel MX-128/ART-13	2-9
<i>b.</i> Oscillator CDA-T	2-9
4. Inter-Unit Connections	2-10
5. Inspection and Test after Installation	2-10
6. Adjustments	2-10
<i>a.</i> Use of Calibration Tables	2-10
<i>b.</i> Procedures for Setting the Controls of Radio Transmitter Set AN/ART-13A (Manual or Autotune Operation)	2-12
<i>c.</i> Simplified Procedure for Setting the Controls	2-18
III. OPERATION	2-22—3-0
1. Starting and Stopping the Equipment	2-22—3-0
<i>a.</i> To Start	2-22—3-0
<i>b.</i> To Stop	2-22—3-0

T. O. 12R2-2ART13-2

<i>Section</i>	<i>Page</i>
2. Operation During Normal Use	2-22—3-0
3. Corrective Measures If Normal Operation Is Not Obtained	3-1
<i>a.</i> Fuse or Circuit Breaker Failure	3-1
<i>b.</i> Remote Control Unit or Cable Failure	3-1
<i>c.</i> Tube Failures	3-1
<i>d.</i> Autotune Failure	3-1
<i>e.</i> Antenna Loading Unit Failure	3-1
<i>f.</i> Vacuum Switch Failure	3-1
<i>g.</i> Cold Weather Failure	3-1
 IV. THEORY OF OPERATION	 4-0
1. Description of Operation	4-0
<i>a.</i> General	4-0
<i>b.</i> Origin of Carrier Frequency	4-0
<i>c.</i> Modulation	4-0
<i>d.</i> First Audio Amplifier, Audio Driver, and Modulator	4-0
<i>e.</i> MCW Oscillator	4-2
<i>f.</i> Power Amplification and Antenna Coupling	4-2
<i>g.</i> Antennas	4-2
<i>h.</i> Sidetone Amplifier	4-2
<i>i.</i> Calibration Frequency Indicator ("CFI") Unit	4-2
<i>j.</i> Generation	4-2
<i>k.</i> Output	4-2
2. Detailed Analysis of Major Circuits	4-4
<i>a.</i> Power Control Circuits	4-4
<i>b.</i> Filament Circuits	4-6
<i>c.</i> High Voltage Circuits	4-7
<i>d.</i> Emission Selection and Carrier Control	4-8
<i>e.</i> Audio Circuits	4-10
<i>f.</i> "CFI" Calibration Oscillator Unit	4-11
<i>g.</i> Radio-Frequency Circuits Radio Transmitting Set AN/ART-13A	4-13
<i>b.</i> Radio-Frequency Circuits Radio Transmitting Set AN/ART-13B	4-17
3. The Autotune System	4-19
<i>a.</i> Mechanical Characteristics	4-19
<i>b.</i> Electrical Characteristics	4-24
<i>c.</i> Operation Cycle of Autotune Mechanism	4-25
<i>d.</i> Functions Performed by the Autotune System	4-27
 V. MAINTENANCE	 4-28—5-0
1. Inspections	4-28—5-0
<i>a.</i> Pre-Flight Inspection	4-28—5-0
<i>b.</i> Daily Inspection	5-1
<i>c.</i> 100-Hour Inspection	5-2
2. Trouble Shooting in the Plane	5-2
<i>a.</i> Simplified Trouble Shooting on Installed Equipment	5-3
<i>b.</i> Tube Checking and Replacement	5-10
3. Trouble Shooting at Repair Station	5-11
<i>a.</i> Trouble Shooting Table	5-11
<i>b.</i> Removing and Servicing Major Assemblies—Obtaining Access to Parts	5-27

<i>Section</i>	<i>Page</i>
4. Maintenance of Autotune Mechanism	5-36
<i>a.</i> Lubrication	5-36
<i>b.</i> Synchronization Check	5-36
<i>c.</i> Synchronization	5-37
<i>d.</i> Autotune Positioning Mechanism	5-38
<i>e.</i> Checking and Adjusting Limit Switches	5-39
<i>f.</i> Replaceable Parts of Autotune Mechanism	5-39
<i>g.</i> Replacing Autotune Parts	5-40
5. Alignment of VFO Radio Frequency Circuits Model AN/ART-13A	5-41
<i>a.</i> Low-Frequency Oscillator Alignment	5-41
<i>b.</i> High-Frequency Oscillator Alignment (Using "CFI")	5-42
<i>c.</i> High-Frequency Oscillator Alignment (Using External Frequency Standard)	5-44
<i>d.</i> Frequency Multiplier Alignment	5-44
6. Alignment of Crystal-Controlled Radio Frequency Circuits— Model AN/ART-13B	5-46
<i>a.</i> Low-Frequency Oscillator Alignment	5-46
<i>b.</i> High Frequency Oscillator Alignment	5-46
7. Alignment of CFI Unit	5-47
<i>a.</i> General Calibration Instructions	5-47
<i>b.</i> Precision Calibration	5-47
<i>c.</i> Approximate Calibration	5-48
8. Adjusting of MCW Oscillator	5-49
9. Replacing and Adjusting Vacuum Contact S116	5-49
 VI. SUPPLEMENTARY DATA	 5-51—6-1
1. Calibration Tables 6-9 and 6-10	5-51—6-1
2. Tables of Approximate Control Settings (for Antenna Tuning and Loading) — Table 6-11	5-51—6-1
3. General Specifications of Equipment	5-51—6-1
<i>a.</i> Range of Available Transmission Frequencies	5-51—6-1
<i>b.</i> Frequency Stability	6-2
<i>c.</i> Antenna Requirements	6-2
<i>d.</i> R-F Power Output	6-2
<i>e.</i> Modulation	6-2
<i>f.</i> Power Input Requirements	6-2
<i>g.</i> Dynamotor	6-2
<i>b.</i> Tube Complement	6-2
<i>i.</i> Audio Input Impedance	6-3
<i>j.</i> Overall Audio Frequency Response	6-3
<i>k.</i> Sidetone Output	6-4
<i>l.</i> Audio Input	6-4
<i>m.</i> Noise Level	6-4
<i>n.</i> Audio Distortion	6-4
<i>o.</i> Sidetone Distortion	6-4
<i>p.</i> Resistance Measurements of Autotune Motor	6-4
 VII. PARTS CATALOG	 7-0
 VIII. DRAWINGS	 8-1

LIST OF TABLES

<i>Table</i>	<i>Page</i>
1-1. AN/ART-13A Equipment Supplied	1-1
1-1A. AN/ART-13B Equipment Supplied	1-1
1-2. Equipment Required but Not Supplied	1-3
1-3. Vacuum Tube Complement	1-7
1-4. Power Input Requirements	1-7
1-5. Required Antenna Characteristics	1-8
1-6. Interchangeability of Major Units	1-10
2-1. Use of Antenna Shunt Capacitor with Antennas of Different Lengths....	2-14
2-2. CDA-T—Crystal-Controlled Oscillator/Multiplier Operation	2-19
2-3. VFO—Oscillator/Multiplier Operation	2-19
4-1. Frequency Range Covered by Positions of High Frequency Tuning Control "A"	4-16
4-2. Function of Multi-Section Output Network Switch S113	4-19
5-1. Trouble Shooting on Installed Equipment	5-3
5-2. Trouble Shooting at Repair Station	5-12
5-3. Voltage-to-Ground from Vacuum Tube Terminals	5-31
5-4. Voltage-to-Ground from Cable Connector Terminals	5-32
5-5. Resistance-to-Ground from Vacuum Tube Terminals	5-33
5-6. Resistance-to-Ground from Cable Connector Terminals	5-34
5-6A. Resistance-to-Ground from Tube and Connector Terminals— CDA-T Unit	5-35
5-7. Replaceable Autotune Parts	5-39
6-1. Range of Available Transmission Frequencies in Low Frequency Range	5-51—6-1
6-2. Range of Available Transmission Frequencies in High Frequency Range	6-2
6-3. R-F Power Output	6-2
6-4. Power Input Requirements	6-2
6-5. Dynamotor Characteristics and Resistance Measurements	6-3
6-6. Vacuum Tube Complement	6-3
6-7. Sidetone Output	6-3
6-8. Resistance Measurements of Autotune Motor	6-4
6-9. Calibration of Low Frequency Oscillator (200 KC to 600 KC)	6-5
6-10. Calibration of High Frequency Oscillator (2000 KC to 18100 KC)	6-6
6-11. Tables of Approximate Dial Settings (for Antenna Tuning and Loading)	6-47

LIST OF ILLUSTRATIONS

<i>Figure</i>		<i>Page</i>
1-1.	Radio Transmitting Set AN/ART-13A—Major Assemblies	1-0
1-1A.	Radio Transmitting Set AN/ART-13B—Major Assemblies	1-2
1-2.	Radio Transmitter T-47A/ART-13	1-4
1-2A.	Radio Transmitter T-412/ART-13B—Front View	1-4
1-3.	Radio Transmitter T-47A/ART-13—Units Removed	1-5
1-3A.	Radio Transmitter T-412/ART-13B and Removable Units	1-6
1-4.	Dynamotor Unit DY-17/ART-13A	1-7
1-5.	Control Unit C-87/ART-13	1-8
1-6.	Control Panel C-405/A	1-8
1-7.	Antenna Loading Unit CU-32/ART-13A—Front View	1-9
1-8.	Antenna Shunt Capacitor CU-24/ART-13	1-9
2-1.	Tube Replacement Diagram	2-2
2-1A.	Tube Replacement Diagram AN/ART-13B	2-3
2-2.	Microphone Selector Switch and Sidetone Output Switch	2-4
2-3.	MCW-CFI Unit—Top View	2-4
2-4.	Transmitter and Mounting Plate MT-283/ART-13, shown with Mounting Bases MT-284/ART-13 and MT-284A/ART-13	2-5
2-5.	Dynamotor Unit DY-17/ART-13A with Mounting Plate MT-164/ART-13	2-6
2-6.	Antenna Loading Unit CU-32/ART-13A with Mounting Base MT-198/ART-13A	2-8
2-7.	Control Unit C-87/ART-13 with Mounting Plate MT-163/ ART-13	2-9
2-8.	Illustration Showing Setting of Control "B" to 1114.1	2-11
2-9.	Radio Transmitter T-47A/ART-13	2-11
2-9A.	Radio Transmitter T-412/ART-13B—Front View	2-12
2-10.	Antenna Loading Unit CU-32/ART-13A—Front View	2-17
2-11.	Crystal Controlled Oscillator Unit (CDA-T)—Front Side View	2-21
4-1.	Radio Transmitting Set AN/ART-13A—Block Diagram	4-1
4-1A.	Radio Transmitting Set AN/ART-13B—Block Diagram	4-1
4-2.	Power Control Circuits	4-3
4-3.	Filament Circuits AN/ART-13A and AN/ART-13B	4-3
4-3A.	Filament Circuits AN/ART-13B	4-7
4-4.	High Voltage Circuits	4-7
4-5.	Emission Selection and Carrier Control Circuits AN/ART-13A	4-8
4-5A.	Emission Selection and Carrier Control Circuits AN/ART-13B	4-9
4-6.	Speech Amplifier Circuits	4-9
4-7.	Modulator Circuit	4-10
4-8.	Sidetone Amplifier Circuit	4-11
4-9.	MCW Oscillator Circuit	4-11
4-10.	CFI Oscillator Circuits	4-12
4-11.	VFO Low Frequency R-F Circuits AN/ART-13A	4-12
4-11A.	Low Frequency R-F Circuits—Crystal-Controlled Operation AN/ART-13B	4-14
4-12.	High Frequency R-F Circuits—VFO Operation AN/ART-13A	4-14
4-12A.	High Frequency R-F Circuits—Crystal-Controlled Operation AN/ART-13B	4-15
4-13.	Power Amplifier and High Frequency Output Circuits	4-18
4-14.	Autotune Mechanism—Mechanical Portion	4-20
4-15.	Singleturn Autotune Unit (Type 96J)—Left Side View	4-22

<i>Figure</i>	<i>Page</i>
4-16. Singleturn Autotune Unit (Type 96J)—Right Side View	4-22
4-17. Multiturn Autotune Unit (Type 96K)—Left Side View	4-22
4-18. Multiturn Autotune Unit (Type 96K)—Right Side View	4-22
4-19. Autotune Casting	4-24
4-20. Electrical Portion of Autotune System	4-24
4-21. Sequence of Autotune Operation	4-26
5-1. Tube Replacement Diagram AN/ART-13A	5-10
5-2. Location of Brushes on Russell Dynamotor	5-23
5-3. Location of Brushes on General Electric Dynamotor	5-24
5-3A. Initial Disassembly of Eicor Dynamotor	5-25
5-3B. Exploded View of Eicor Dynamotor	5-26
5-4. Component Parts of Russell Dynamotor	5-27
5-5. Component Parts of General Electric Dynamotor	5-28
5-6. Radio Transmitter T-47A/ART-13 and Removable Units	5-30
5-7. Low Frequency Oscillator	5-41
5-7A. Crystal-Controlled Oscillator Unit (CDA-T)—Top View	5-43
5-8. High Frequency Oscillator—Side View, Open	5-45
5-9. Frequency Multiplier	5-46
5-10. MCW-CFI Unit—Top View	5-48
5-11. Keying Relay K102 and Vacuum Contact S116	5-50
6-1. Overall Audio Frequency Response Curve	6-3
8-1. Radio Transmitter T-47A/ART-13—Front View, Open	8-2
8-2. Radio Transmitter T-47A/ART-13—Top View, Cover Removed ..	8-3
8-2A. Radio Transmitter T-412/ART-13B—Top View, Cover Removed ..	8-4
8-3. Radio Transmitter T-47A/ART-13—Bottom View, Panel Removed	8-5
8-3A. Radio Transmitter T-412/ART-13B—Bottom View, Panel Removed	8-6
8-4. Low Frequency Oscillator Unit (Oscillator O-17/ART-13A) Top View, Open	8-7
8-5. Low Frequency Oscillator Unit (Oscillator O-17/ART-13A) Bottom View, Open	8-8
8-5A. Crystal-Controlled Oscillator Unit (CDA-T)—Top View	8-9
8-5B. Crystal-Controlled Oscillator Unit (CDA-T)—Parts Identification	8-10
8-6. High Frequency Oscillator—Side View, Open	8-11
8-7. Frequency Multiplier—Side View, Open	8-12
8-8. MCW-CFI Unit—Top View	8-13
8-9. MCW-CFI Unit—Bottom View	8-14
8-10. Audio Amplifier Unit—Top View	8-15
8-11. Audio Amplifier Unit—Bottom View	8-16
8-12. Autotune Casting	8-17
8-13. Firewall Assembly—Top View	8-18
8-14. Firewall Assembly—Bottom View	8-19
8-15. Multi-Element Switch—Right Side View	8-20
8-16. Multi-Element Switch—Left Side View	8-20
8-17. Control Unit C-87/ART-13—Front View	8-21
8-17A. Control Unit C-87/ART-13 (Modified*)—Front View	8-21
8-18. Control Unit C-87/ART-13—Rear View, Open	8-22
8-18A. Control Unit C-87/ART-13 (Modified*)—Rear View	8-22
8-19. Control Panel C-405/A—Front View	8-23
8-20. Control Panel C-405/A—Rear View, Open	8-23
8-21. Antenna Loading Unit CU-32/ART-13A—Front View	8-24
8-22. Antenna Loading Unit CU-32/ART-13A—Rear View, Open	8-24

T-O. 12R2-2ART13-2

<i>Figure</i>		<i>Page</i>
8-23.	Antenna Shunt Capacitor CU-24/ART-13	8-25
8-23A.	Eicor Dynamotor DY-17A/ART-13A—Bottom View	8-26
8-24.	Dynamotor Unit DY-17/ART-13A—Bottom View	8-27
8-25.	Radio Transmitter T-47A/ART-13 and Mounting Base MT-284A/ART-13—Outline Dimensions	8-28
8-26.	Control Unit C-87/ART-13—(Modified*)—Outline Dimensions	8-29
8-27.	Antenna Loading Unit CU-32/ART-13A—Outline Dimensions	8-30
8-28.	Mounting Base MT-198/ART-13A—Outline Dimensions	8-31
8-29.	Antenna Shunt Capacitor CU-24/ART-13—Outline Dimensions	8-32
8-30.	Switch SA-46/ART-13—Outline Dimensions	8-33
8-31.	Dynamotor Unit DY-17/ART-13A—Outline Dimensions	8-34
8-32.	Control Panel C-405/A—Outline Dimensions	8-35
8-33.	Plugs for Radio Transmitting Set AN/ART-13A	8-36
8-34	Antenna Loading Unit CU-32/ART-13A—Practical Wiring Diagram	8-37
8-35.	Low Frequency Oscillator Unit—Practical Wiring Diagram	8-38
8-36.	MCW-CFI Unit—Practical Wiring Diagram	8-39
8-37.	Audio Amplifier—Practical Wiring Diagram	8-40
8-38.	Control Unit (Modified*)—Practical Wiring Diagram	8-41
8-39.	Dynamotor Unit DY-17/ART-13A—Practical Wiring Diagram	8-42
8-40.	Control Panel C-405/A—Practical Wiring Diagram	8-43—8-44
8-41.	Radio Transmitter T-47A/ART-13—Practical Wiring Diagram	8-45—8-46
8-41A.	Eicor Dynamotor DY-17A/ART-13A—Schematic Diagram	8-47
8-42.	Radio Transmitting Set AN/ART-13A—Schematic Diagram	8-49—8-50
8-43.	Typical Wiring Diagram for Radio Set AN/ARC-8	8-51—8-52
8-44.	Radio Transmitting Set AN/ART-13B—Schematic Diagram	8-53—8-54
8-45.	Antenna Loading Unit CU-32/ART-13A—Test Inter-Connection Diagram	8-55

Destruction of Abandoned Materiel in the Combat Zone

In case it should become necessary to prevent the capture of this equipment and when ordered to do so, DESTROY IT SO THAT NO PART OF IT CAN BE SALVAGED, RECOGNIZED OR USED BY THE ENEMY. BURN ALL PAPERS AND BOOKS.

Means:—

1. Explosives, when provided.
2. Hammers, axes, sledges, machetes, or whatever heavy object is readily available.
3. Burning by means of incendiaries such as gasoline, oil, paper, or wood.
4. Grenades and shots from available arms.
5. Burying all debris or disposing of it in streams or other bodies of water, where possible and when time permits.

Procedure:—

1. Obliterate all identifying marks. Destroy nameplates and circuit labels.
2. Demolish all panels, castings, switch- and instrument-boards.
3. Destroy all controls, switches, relays, connections, and meters.
4. Rip out all wiring and cut interconnections of electrical equipment. Smash gas, oil, and water-cooling systems in gas-engine generators, etc.
5. Smash every electrical or mechanical part, whether rotating, moving, or fixed.
6. Break up all operating instruments such as keys, phones, microphones, etc.
7. Destroy all classes of carrying cases, straps, containers, etc.
8. Bury or scatter all debris.

DESTROY EVERYTHING!



Unsatisfactory Report

For U. S. Army Air Force Personnel:

In the event of malfunctioning, unsatisfactory design, or unsatisfactory installation of any of the component units of this equipment, or if the material contained in this book is considered inadequate or erroneous, an Unsatisfactory Report, AAF Form No. 54, or a report in similar form, shall be submitted in accordance with the provisions of Army Air Force Regulation No. 15-54 listing:

1. Station and organization.
2. Nameplate data (type number or complete nomenclature if nameplate is not attached to the equipment).
3. Date and nature of failure.
4. Radio model and serial number.
5. Remedy used or proposed to prevent recurrence.
6. Handbook errors or inadequacies, if applicable.

SAFETY NOTICE

This equipment employs high voltages which are dangerous and may be fatal if contacted by operating personnel. Extreme caution should be exercised when working with the equipment.



IMPORTANT NOTICE

Some parts of this book do not apply to Radio Transmitting Set AN/ART-13A. All of the book does apply to Radio Transmitting Set AN/ART-13B. To determine those parts which are applicable to your particular equipment, the following paragraphs should be carefully read and understood.

In mechanical design, the above two models are identical, which permits interchangeability of all major units, assemblies and sub-assemblies. Electrically, there are major differences.

Model AN/ART-13A is a multi-channel transmitting set, utilizing variable frequency oscillator operation with a frequency range of 2000 Kc. through 18,100 Kc. Its design permits the use of an additional variable frequency oscillator plug-in unit, O-17/ART-13A, which extends the operating range of the transmitting set to include the low frequency 200 Kc. to 600 Kc. band.

Model AN/ART-13B is a modification of the AN/ART-13A, retaining all functions and method of operation of the earlier model, but modifying some circuits to permit the use of a plug-in crystal-controlled oscillator unit, identified as the CDA-T Crystal Control Unit. The CDA-T unit provides twenty additional crystal-controlled channels in the frequency range 1670 Kc. through 18,000 Kc. and four channels in the frequency range 300 Kc. through 500 Kc. The CDA-T Crystal Oscillator and the O-17/ART-13A VFO units are mechanically interchangeable but cannot be used simultaneously since they occupy the same compartment of the transmitting cabinet. To facilitate identification of the text applying solely to Model AN/ART-13B, such paragraphs will be prefaced by either the model number or an asterik (*).

ANTENNA LOADING UNIT CU-32/ART-13A

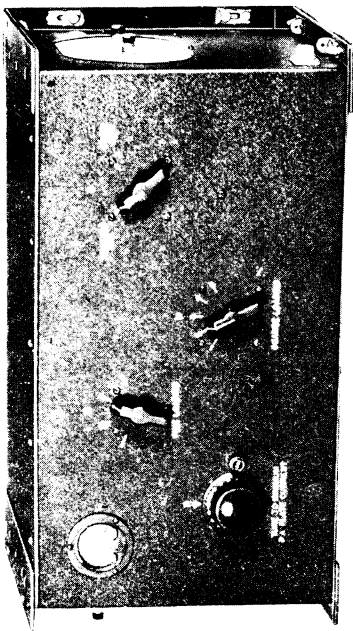

MOUNTING BASE MT-198/ART-13A
(USED WITH ANTENNA LOADING UNIT CU-32/ART-13A)

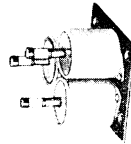
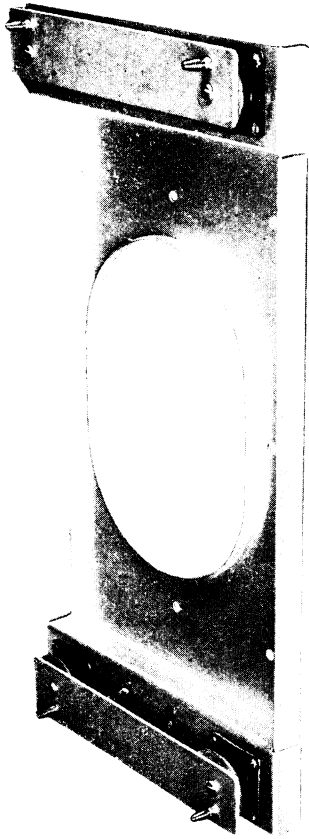

ANTENNA SHUNT CAPACITOR
CU-24/ART-13

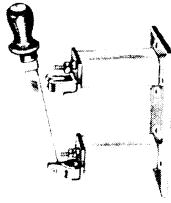

SWITCH SA-46/ART-13A

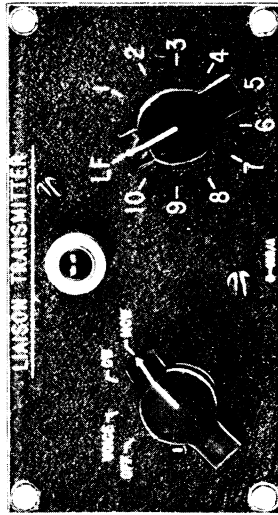

CONTROL PANEL C-405/A

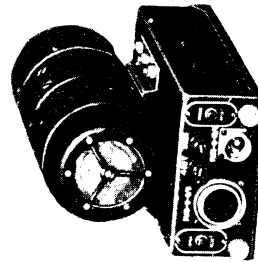

DYNAMOTOR UNIT DY-17/ART-13A
WITH
MOUNTING PLATE MT-164/ART-13

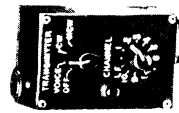

CONTROL UNIT C-87/ART-13
WITH
MOUNTING PLATE MT-163/ART-13

OSCILLATOR O-17/ART-13A

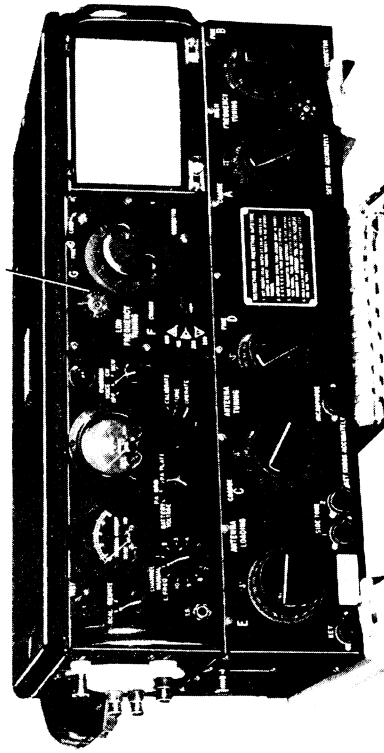

RADIO TRANSMITTER T-47A/ART-13
WITH
MOUNTING PLATE MT-283/ART-13

Figure 1-1. Radio Transmitting Set AN/ART-13A—Major Assemblies

SECTION I

GENERAL DESCRIPTION

1. EQUIPMENT SUPPLIED.

Radio Transmitting Sets AN/ART-13A and

AN/ART-13B, covered by these instructions, consist of units as listed in Tables 1-1 and 1-1A.

TABLE 1-1. AN/ART-13A — EQUIPMENT SUPPLIED

<i>Quantity</i>	<i>Name of Unit</i>	<i>Overall Dimensions (Inches)</i>	<i>Weight (Pounds)</i>	<i>Reference Symbols</i>
1	Radio Transmitter T-47A/ART-13 which includes the following items as issued: Audio Amplifier Unit MCW-CFI Unit Panel MX-128/ART-13 Calibration Book Mounting Plate MT-283/ART-13	23-5/8 x 13-5/8 x 10-3/4	70.0	101 to 199 201 to 299 2201 to 2299
1	Mounting Base MT-284/ART-13 for mounting transmitter	20-1/2 x 14-3/4 x 2-1/2	2.94	—
1	Dynamotor Unit DY-17/ART-13A which includes dynamotor machine, control relays, barometric switch and filters	7-1/8 x 11-7/8 x 8-7/8	28.0	2701 to 2799
1	Mounting Plate MT-164/ART-13 for mounting dynamotor unit	7-1/8 x 11-5/32 x 1-1/4	1.13	—
1	Control Unit C-87/ART-13	3-1/2 x 6-5/32 x 3-1/4	1.44	601 to 699
1	Mounting Plate MT-163/ART-13 for mounting control unit	3-5/8 x 5-1/4 x 1/4	0.11	—
1	Control Panel C-405/A	2-1/2 x 5 x 2-5/8	Approx. 1.5	—
1	Plug U-6/U female cable plug for remote control box, remote control end	1-5/8 dia. x 2-5/32 lng.	0.20	—
1	Plug U-7/U female power cable plug, transmitter end	2 dia. x 2-5/16 lng.	0.25	—
1	Plug U-8/U, male cable plug for remote control, transmitter end	1-3/4 dia. x 1-31/32 lng.	0.19	—
1	Plug U-9/U male power cable plug, dynamotor end	2-1/8 dia. x 1-7/8 lng. x 2-3/4 wide	—	—
1	Plug U-10/U female primary power input cable plug, dynamotor end	1-5/6 dia. x 1-7/8 lng. x 1-7/8 wide	—	—
1	Handbook of Operating Instructions	8-1/2 x 11	—	—
1	The following two items are required when operation is desired between 2000 Kc. and 3000 Kc. with fixed antennas less than 55 ft.			
1	Antenna Shunt Capacitor CU-24/ART-13	5 x 4-1/8 x 4	1.59	1101 to 1199
1	Switch SA-46/ART-13A	6-1/4 x 2 x 4	—	—
1	The following items are required when operation is desired in the range of 200 Kc. to 600 Kc.			
1	Oscillator O-17/ART-13A	—	—	2601 to 2699
1	Mounting Base MT-198/ART-13A	22-1/2 x 10-11/16 x 2	—	—
1	Antenna Loading Unit CU-32/ART-13A	23-1/2 x 13 x 12	24.75	2501 to 2599
1	Plug U-11/U, male cable plug for antenna loading unit, transmitter end	1-1/8 dia. x 1-29/32 lng.	0.12	—
1	Plug U-12/U, female cable plug for antenna loading unit, load unit end	1-1/8 dia. x 2 x 1-15/32	0.12	—

TABLE 1-1A. AN/ART-13B — EQUIPMENT SUPPLIED

<i>Quantity</i>	<i>Name of Unit</i>	<i>Overall Dimensions (Inches)</i>	<i>Weight (Pounds)</i>	<i>Reference Symbols</i>
1	Radio Transmitter T412/ART-13B which includes the following items as issued: Audio Amplifier Unit MCW-CFI Unit Panel MX-128/ART-13 Calibration Book Mounting Plate MT-283/ART-13	23-5/8 x 13-5/8 x 10-3/4	70.0	101 to 199 201 to 299 2201 to 2299
1	Mounting Base MT-284/ART-13 for mounting transmitter	20-1/2 x 14-3/4 x 2-1/2	2.94	—

TABLE 1-1A. AN/ART-13B — EQUIPMENT SUPPLIED (Continued)

Quantity	Name of Unit	Overall Dimensions (Inches)	Weight (Pounds)	Reference Symbols
1	Dynamotor Unit DY-17/ART-13A which includes dynamotor machine, control relays, barometric switch and filters	7-1/8 x 11-7/8 x 8-7/8	28.0	2701 to 2799
1	Mounting Plate MT-164/ART-13 for mounting dynamotor unit	7-1/8 x 11-5/32 x 1-1/4	1.13	—
1	Control Unit C-87/ART-13 (modified)	3-1/2 x 6-5/32 x 3-1/4	1.44	601 to 699
1	Mounting Plate MT-163/ART-13 for mounting control unit	3-5/8 x 5-1/4 x 1/4	0.11	—
1	Control Panel C-405/A	2-1/2 x 5 x 2-5/8	Approx. 1.5	—
1	Plug U-6/U female cable plug for remote control box, remote control end	1-5/8 dia. x 2-5/32 lng.	0.20	—
1	Plug U-7/U female power cable plug, transmitter end	2 dia. x 2-5/16 lng.	0.25	—
1	Plug U-8/U, male cable plug for remote control, transmitter end	1-3/4 dia. x 1-31/32 lng.	0.19	—
1	Plug U-9/U male power cable plug, dynamotor end	2-1/8 dia. x 1-7/8 lng. x 2-3/4 wide	—	—
1	Plug U-10/U female primary power input cable plug, dynamotor end	1-5/6 dia. x 1-7/8 lng. x 1-7/8 wide	—	—
1	Handbook of Operating Instructions The following two items are required when operation is desired between 1670 Kc. and 3000 Kc. with fixed antennas less than 55 ft.	8-1/2 x 11	—	—
1	Antenna Shunt Capacitor CU-24/ART-13	5 x 4-1/8 x 4	1.59	1101 to 1199
1	Switch SA-46/ART-13A	6-1/4 x 2 x 4	—	—
1	Crystal Control Unit CDA-T The following items are required when operation is desired in the range of 300 Kc. to 500 Kc.	5-3/8 x 9-1/2 x 6-1/2	3.88	801 to 899
1	Mounting Base MT-198/ART-13A	22-1/2 x 10-11/16 x 2	—	—
1	Antenna Loading Unit CU-32/ART-13A	23-1/2 x 13 x 12	24.75	2501 to 2599
1	Plug U-11/U, male cable plug for antenna loading unit, transmitter end	1-1/8 dia. x 1-29/32 lng.	0.12	—
1	Plug U-12/U, female cable plug for antenna loading unit, load unit end	1-1/8 dia. x 2 x 1-15/32	0.12	—

2. EQUIPMENT REQUIRED BUT NOT SUPPLIED.

Items listed in table 1-2 are used to complete an installation but are not supplied with the equipment.

TABLE 1-2. EQUIPMENT REQUIRED BUT NOT SUPPLIED

Quantity	Name of Unit	Required Characteristics
1	Microphone T-17 or T-30. (Microphone T-30 requires cord CD-318 or CD-508)	Carbon microphone with 40 to 100 ohms internal impedance
1	Key J-37	
1	Headset HS-33 or HS-38	300 ohm impedance
1	Antenna Equipment AN/ARA-4 or Antenna Assembly AS-315/A	Fixed and trailing wire type antennas
1	All Cables and Wiring	Open wiring. See fig. 8-43 all cable and wiring requirements
*20	Quartz Crystal Units	Type CR-7
* 2	Quartz Crystal Units	Western Electric Type 5A
* 1	Quartz Crystal Unit, dual type	Western Electric Type 5D

3. GENERAL DESCRIPTION OF EQUIPMENT.

Radio Transmitting Sets AN/ART-13A and AN/ART-13B are medium power, aircraft radio transmitters, designed to provide radio communication by

voice, modulated continuous wave telegraphy (MCW), or continuous wave telegraphy (CW). Either a carbon or dynamic microphone may be used for voice emission. The audio system is capable of modulating the carrier (100 watts nominal) at least 90 percent for MCW or Voice emission. When operating with CW or MCW emission, entirely satisfactory performance will be obtained for keying speeds up to 30 words per minute. Transmission frequencies differ between the Models AN/ART-13A and AN/ART-13B as outlined in the following paragraphs. Shifting from one transmission to another can be accomplished by the conventional method of "hand-positioning" the controls or by using the built-in automatic shifting mechanism known as the "Autotune". This automatic mechanism is also utilized to provide remote control of functions required to shift transmission frequency.

a. TRANSMITTERS.—Sub-assembly type of construction has been used extensively in Radio Transmitters T-47A/ART-13 and T-412/ART-13B. This type of construction greatly simplifies the removal of component parts without major disassembly of the unit. The MCW-CFI, the Audio Amplifier, and the plug-in oscillator units (Type O-17/ART-13A used in both AN/ART-13A and AN/ART-13B; Type CDA-T used only in AN/ART-13B) are connected by multi-terminal plugs to facilitate removal for servicing (see figures 1-3 and

*Applies only to AN/ART-13B

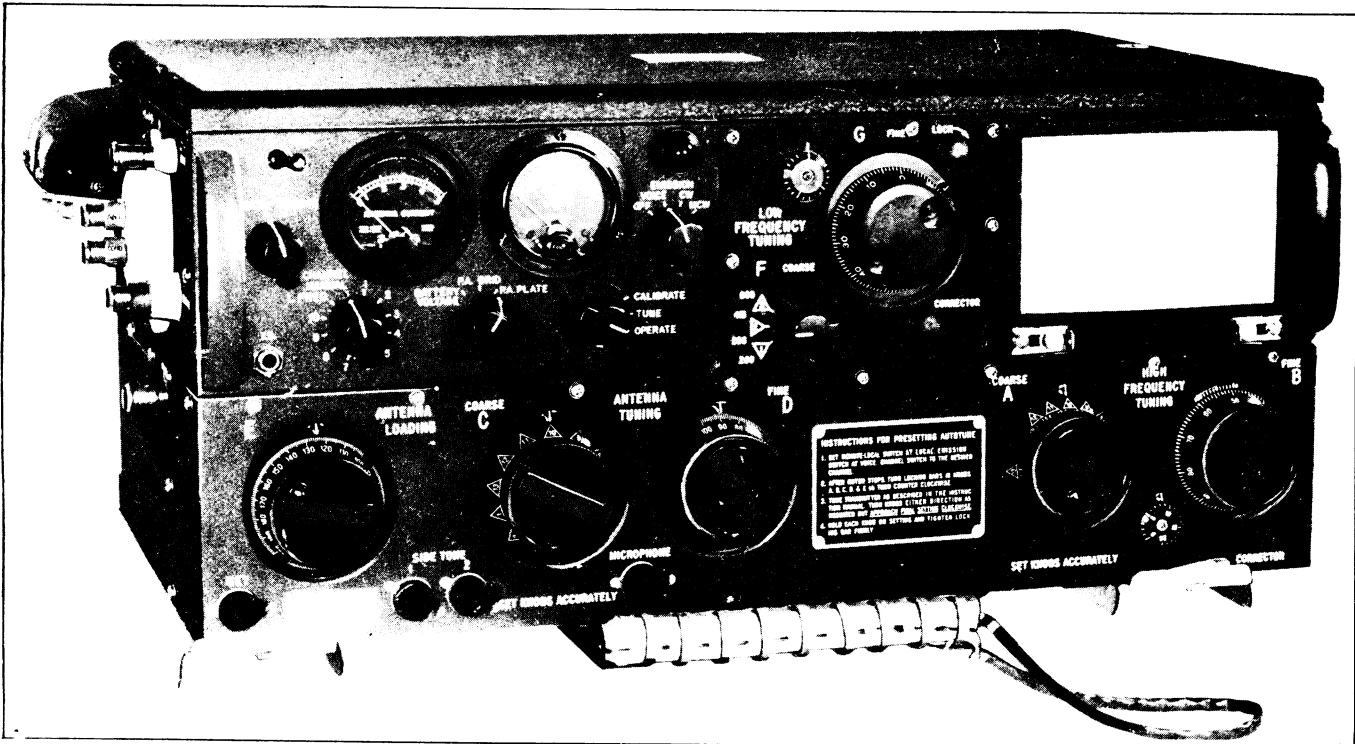

Figure 1-2. Radio Transmitter T-47A/ART-13

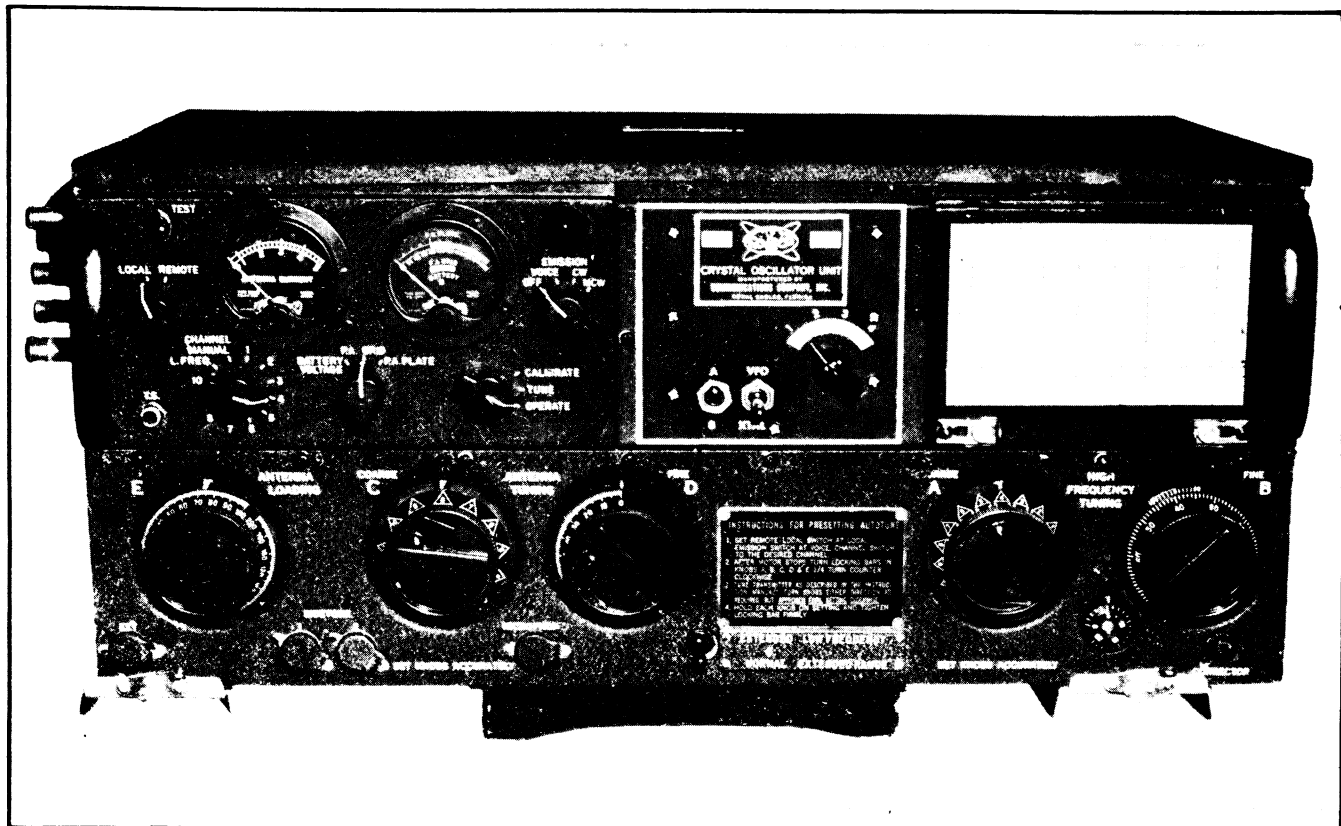

Figure 1-2A. Radio Transmitter T-412/ART-13B — Front View

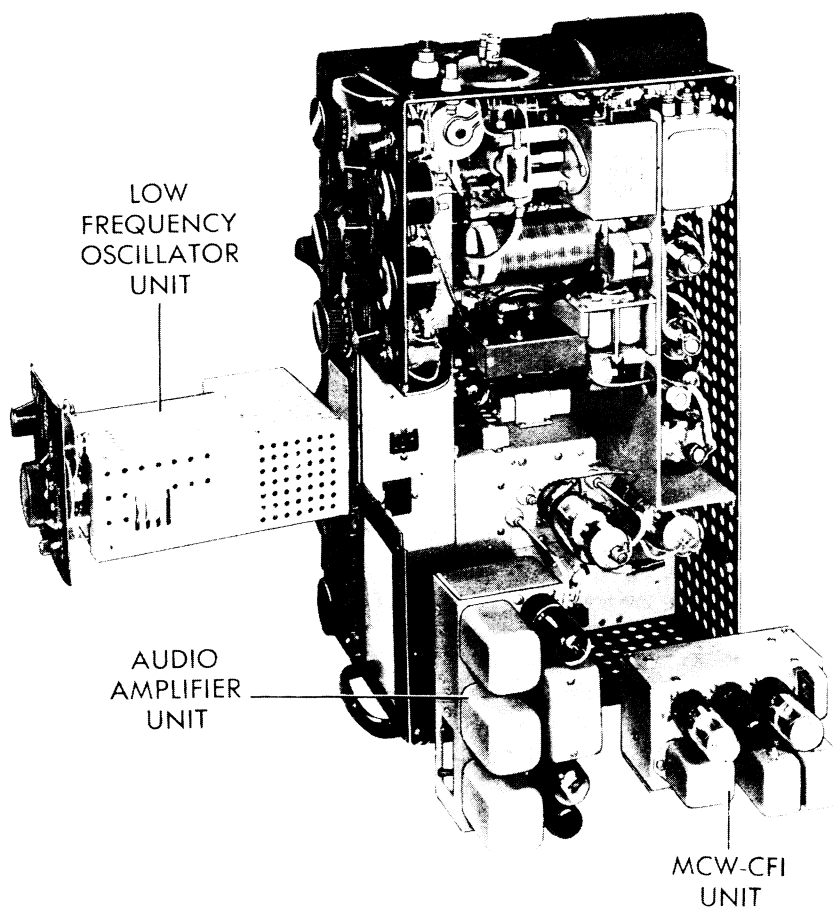

Figure 1-3. Radio Transmitter T-47A/ART-13 — Units Removed

1-3A). Particular attention was given to accessibility of component parts so that replacement could be accomplished quickly and easily. Vacuum tubes are accessible by removal of the top cover of the transmitter case.

(1) TRANSMITTER T-47A/ART-13. Used as the basic unit of Radio Transmitting Set AN/ART-13A, this transmitter (see fig. 1-2) provides variable frequency oscillator (VFO) operation with two bands of transmission frequencies available. Normal frequency range of this unit is 2000 kc. through 18,100 kc. Output may be obtained in the low frequency range of 200 kc. to 600 kc. by using Oscillator O-17/ART-13A which is not a part of the transmitter but may be installed upon removal of Panel MX-128/ART-13.

(2) TRANSMITTER T-412/ART-13B.—Used as the basic unit of Radio Transmitting Set AN/ART-13B, this transmitter (see fig. 1-2A) provides both variable frequency oscillator and crystal-controlled oscillator operation. Four bands of transmission frequencies are available. The basic unit, utilizing VFO operation, covers the frequency range of 2000 kc. to 18,100 kc. Plug-in oscillator units are required to obtain additional frequency ranges. Low frequency VFO unit O-17/ART-13A covers the range 200 kc. to 600 kc. When the

CDA-T unit is utilized, two crystal-controlled frequency bands are provided, one covering the range 1670 kc. to 18,000 kc. and the other 300 kc. to 500 kc.

(a) LOW FREQUENCY RANGE.—When the transmitter is operated in the radio frequency range 300 kc. to 500 kc. Antenna Loading Unit CU-32/ART-13A must be used to tune and deliver power to either a trailing wire antenna (approximately 200 ft. long) or a fixed aircraft antenna (from 17 to 65 ft. long).

(b) HIGH FREQUENCY RANGE.—When the transmitter is operated in the radio frequency range 1670 kc. to 18,100 kc. the antenna tuning network, incorporated in the transmitter, is capable of tuning and delivering power into fixed aircraft antennas which are between 17 and 65 feet in length. For operation over the radio-frequency range 1670 kc. to 3000 kc. Antenna Shunt Capacitor CU-24/ART-13 may be required, in addition to the antenna tuning network in the transmitter, to tune and deliver power to fixed aircraft antennas which are between 20 and 60 feet in length.

(3) CHANGING TRANSMISSION FREQUENCY.—The transmission frequency of AN/ART-13A may be changed by the conventional method of manually setting each control, or can be changed to any one of ten predetermined frequencies (eleven, when using

the O-17/ART-13A unit) by means of the automatic tuning system known as the "Autotune". Radio Transmitting Set AN/ART-13B, when operating VFO, uses the above procedures. When operating crystal-controlled, the AN/ART-13B controls may be manually set in the usual manner but use of the "Autotune" provides only semi-automatic shifting of the frequency, as additional switches on the CDA-T panel must be operated manually to obtain output in all of the twenty high frequency and four low frequency channels.

(a) **AUTOMATIC TUNING.**—The "Autotune" system has been incorporated in the transmitter to permit rapid change from one transmission frequency to another. It will operate to change frequency of transmission in less than 25 seconds at normal temperatures and battery voltage. This automatic tuning system is electrically controlled by means of mechanically repositioning adjustable elements such as switches, variable inductors and variable capacitors. The accuracy of repositioning is of a very high order and is not seriously affected by wear, humidity or temperature changes. No tools are necessary to change the settings for any of the predetermined transmission frequencies. A detailed description of construction and operation of the Autotune is given in Section IV of this manual.

(b) **MANUAL TUNING.**—The transmission frequency may be changed manually if desired. This is accomplished by first setting the "CHANNEL SELECTOR SWITCH" to the "MANUAL" position. All control knobs can then be manually operated without disturbing the settings of the Autotune system.

(4) **AUDIO INPUT FOR VOICE EMISSION.**—The audio input circuit incorporated in this equipment permits the use of either a carbon or dynamic type of microphone.

(5) **POWER OUTPUT.**—The power delivered to the antenna varies with frequency and antenna characteristics. See section VI for typical values of power output.

(a) The power output is automatically reduced to approximately one-half the full power output when an altitude between 20,000 and 25,000 feet is reached. This is accomplished by means of a pressure operated switch which reduces high voltage on the plate of the 813 power amplifier tube and the two 811 modulator tubes. The transmitter will then operate without "flash-over" up to an altitude of 40,000 feet above sea level. This "BAROMETRIC" switch reduces power output at altitudes above 20,000 to 25,000 ft. and permits full power output at altitudes below this value.

(6) **TUBE COMPLEMENT.**—The complete vacuum tube complement for this equipment is given in table 1-3.

b. **DYNAMOTOR UNIT.**—Dynamotor Unit DY-17/ART-13A is the power source for Transmitters T-47A/ART-13 and T-412/ART-13B. It contains the Dynamotor Machine, Barometric Switch, Control and Overload Relays, Filters and Fuse for overload protection of the 400 volt supply circuits. A 28 volt direct current power source is required for operation of the dynamotor machine as well as for the circuits in the transmitter. Voltages as low as 24 volts d-c may

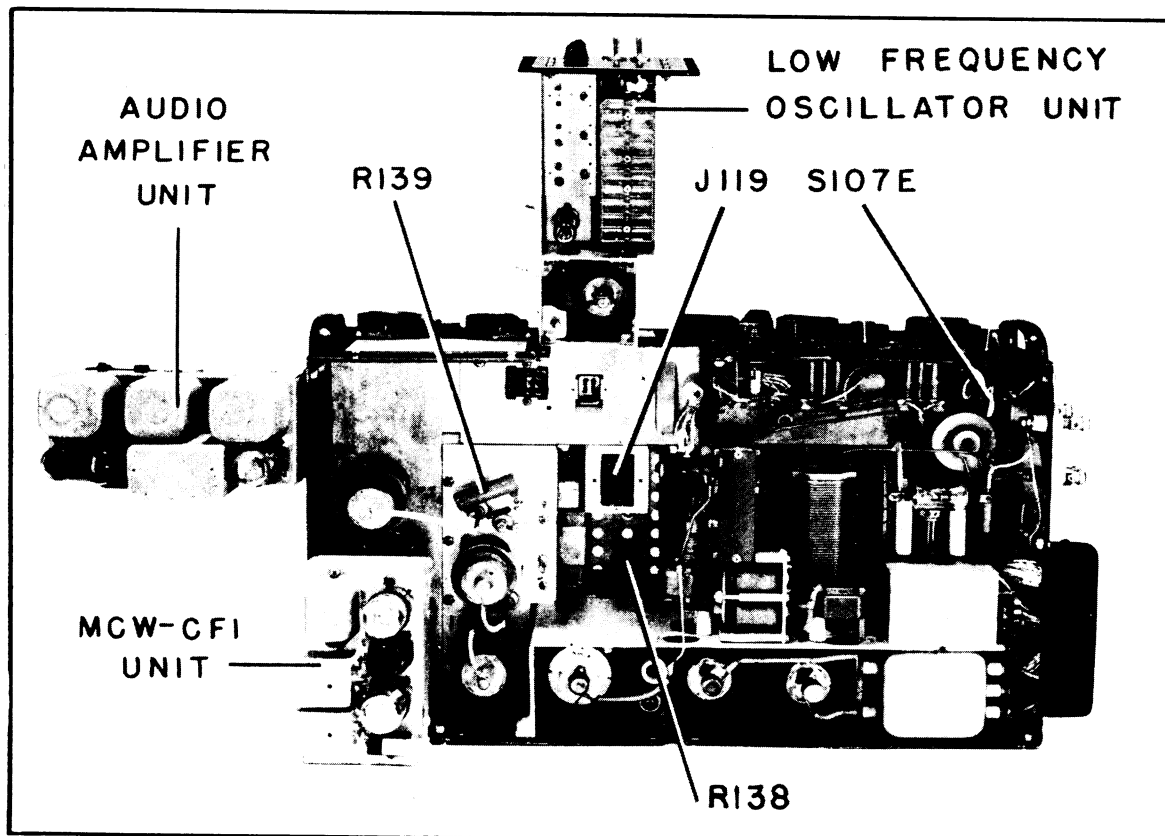

Figure 1-3A.
Radio Transmitter
T-412/ART-13B
and
Removable Units

TABLE 1-3. VACUUM TUBE COMPLEMENT

Symbol Designation	Type Number	Army-Navy Specification	Circuit Function
V101	JAN-837	JAN-1A	High Freq. Oscillator
V102	JAN-1625	JAN-1A	1st Multiplier
V103	JAN-1625	JAN-1A	2nd Multiplier
V104	JAN-813	JAN-1A	Power Amplifier
V105	JAN-811	JAN-1A	Modulator
V106	JAN-811	JAN-1A	Modulator
V201	JAN-12SJ7	JAN-1A	1st Audio Amplifier
V202	JAN-6V6GT	JAN-1A	Audio Driver
V203	JAN-6V6GT	JAN-1A	Sidetone Amplifier
V2201	*JAN-12SL7GT	JAN-1A	} 1st Section is 200 Kc Calibration Osc. } 2nd Section is Frequency Tripler Converter
V2202	†JAN-12SA7	JAN-1A	
V2203	*JAN-12SL7GT	JAN-1A	} 1st Section is Signal Detector } 2nd Section is MCW Audio Oscillator
V2601	JAN-1625	JAN-1A	
V801	‡JAN-6AQ5	JAN-1A	High Freq. Crystal Oscillator
V802	‡JAN-1625	JAN-1A	Low Freq. Crystal Oscillator

*Types JAN-12SL7GT or JAN-12SL7 may be used interchangeably.
†Types JAN-12SA7GT or JAN-12SA7 may be used interchangeably.
‡Used only in AN/ART-13B.

be used but reduction in power output and increased time required for Autotune operation will result.

(1) The dynamotor machine employs an armature with dual windings and two commutators to give output voltages of 400 and 750 volts d-c. A barometric switch incorporated in the dynamotor unit chassis connects the two windings of the dynamotor in series at altitudes below 20,000 to 25,000 feet. At higher altitudes the series connection is broken. This arrangement provides either 1150 or 750 volts for the high voltage supply circuits of the transmitter, the voltage being automatically reduced from 1150 to 750 when equipment is operated at a high altitude.

TABLE 1-4. POWER INPUT REQUIREMENTS

Type of Emission Used	Frequency	Power Input (Watts)	
		Full Power	Reduced Power
CW	3.0 Mc.	780	700
CW (Stand By)	3.0 Mc.	560	560
MCW	3.0 Mc.	925	760
MCW (Stand By)	3.0 Mc.	560	560
Voice (90% Mod.)	3.0 Mc.	925	760
Voice (Stand By)	3.0 Mc.	250	250

(2) Table 1-4 shows typical power input requirements for a supply voltage of 28 volts d-c. Data is shown for different types of emission and for full or reduced power INPUT (reduced power INPUT being obtained by operation of barometric switch at altitudes above 20,000 to 25,000 feet). All measurements made with power amplifier loaded to rated P.A. plate current.

c. CONTROL UNITS.—Control Unit C-87/ART-13 (see fig. 1-5) used with Radio Transmitting Set AN/ART-13A and a modified version of this unit (see fig. 1-1A) used with Radio Transmitting Set AN/ART-13B, provide a means of operating the transmitter from a remote position. These two controls differ only by the addition of a toggle switch in the modified version. One knob on each unit permits the power supply to be turned

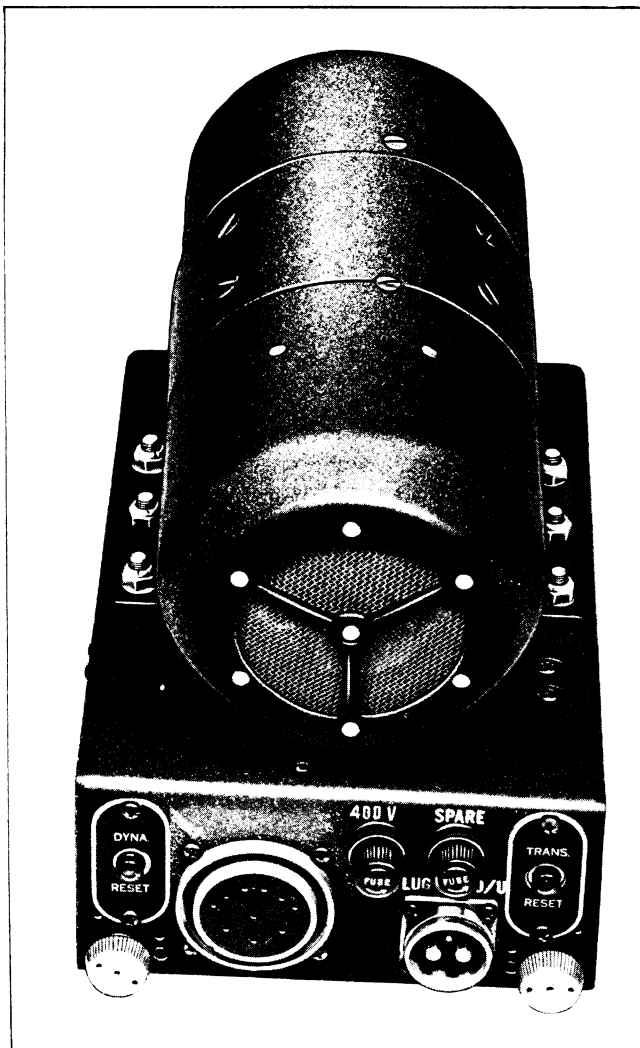

Figure 1-4. Dynamotor Unit DY-17/ART-13A

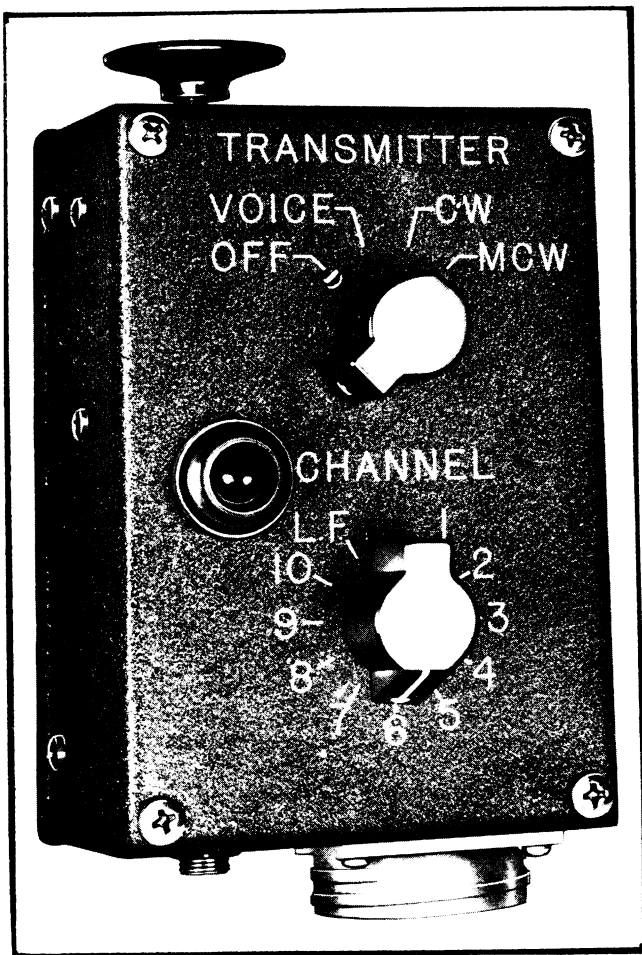

Figure 1-5. Control Unit C-87/ART-13

on and off, and selects the type of emission (CW, MCW or VOICE). A second knob operates the Autotune and permits selection of any one of eleven preset frequency channels. The control unit used with AN/ART-13B utilizes a toggle switch which allows selection of two frequencies for each of the ten high frequency channels of the Autotune system, provided the remote transmitter is using crystal-controlled operation.

(1) The pilot lamp on the control unit will operate when the emission selector switch is in any position other than the "OFF" position (providing Autotune System is at rest). The pilot lamp will light only when the remote position is in control. The pilot lamp on the transmitter performs the same function when the transmitter controls are being used. If Autotune is in process of changing the transmission frequency, the pilot lamp will remain off until the Autotune cycle is completed. Thus, the pilot lamp serves a dual purpose by indicating that the power supply has been connected to the equipment and to let the operator know when the Autotune has completed the change from one transmission frequency to another so that the carrier is again ready to be keyed or voice modulated.

(2) Both control units mount a key, used for keying the transmitter on "CW" or "MCW" and a jack for connection of a microphone for "VOICE" operation.

d. CONTROL PANEL.—For installations having standardized control panels, Control Panel C-405/A replaces and performs all the functions (except key) of Control Unit C-87/ART-13. See figure 1-6.

Note

Control Panel C-405A/A may be supplied instead of C-405/A. Control Panel C-405A/A differs from the C-405/A model in that it has an edge-lighted lucite panel and two panel lamps. It is mechanically and electrically interchangeable with the C-405/A except that it has an additional wire to bring power to the lamps.

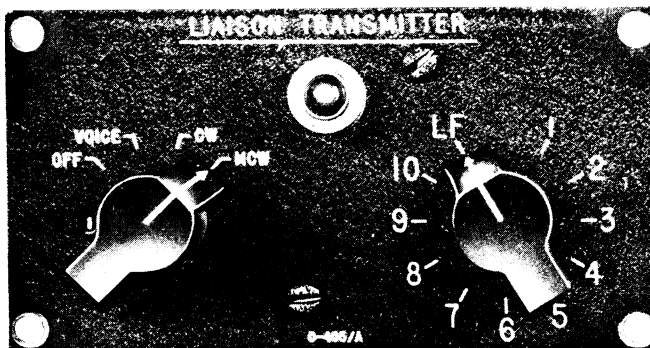

Figure 1-6. Control Panel C-405/A or C-405A/A

e. ANTENNA LOADING UNIT.—Antenna Loading Unit CU-32/ART-13A is required to tune and deliver power to either a trailing wire or fixed aircraft antenna when the transmitter is operated in the 200 kc to 600 kc frequency range. This loading unit is designed to accommodate antennas whose characteristics are within the range shown in table 1-5.

TABLE 1-5.
REQUIRED ANTENNA CHARACTERISTICS

Freq. In KC.	Effective Resistance In Ohms	Effective Capacity In Mmfd.	Freq. In KC.	Effective Resistance In Ohms	Effective Capacity In Mmfd.
200 to 600	3 to 10	85 to 175	200 to 600	3 to 15	300 to 450

When transmission frequencies in the 200 kc to 600 kc range are selected, the antenna tuning and loading circuits, built into the transmitter, are not used and the output of the power amplifier is automatically connected to the loading circuits in the antenna loading unit.

(1) Controls are provided on the front panel to permit adjustment of inductive reactance and coupling in order to tune and deliver power to the antenna. A radio frequency ammeter is used to indicate antenna current. Selection of either the trailing wire or fixed aircraft antenna is accomplished by means of a switch located on the front panel of the loading coil.

(2) Terminal posts on both side panels facilitate connections to a fixed aircraft antenna, trailing wire antenna, ground (structure of aircraft), the high frequency antenna terminal of the transmitter, the low



Figure 1-7. Antenna Loading Unit CU-32/ART-13A—Front View

frequency terminal of the transmitter, and to a 28 volt supply source which is controlled by the output circuit selecting relay (K105) in the transmitter. The 28 volt d-c source is "keyed" by microphone or telegraph key and actuates a relay in the loading unit. This relay either connects the aircraft antenna to the high frequency antenna terminal of the transmitter or connects aircraft antenna to the circuits of the loading unit. Thus, automatic selection of the correct antenna tuning and loading system is accomplished for either high or low frequency operation when the transmitter controls are being set to the desired transmission frequency.

(3) When both the trailing wire antenna and the fixed antenna are connected to the loading unit, only one or the other is actually in use for any transmission frequency. The idle antenna is, at all times, automatically connected to a terminal post on the exterior of the unit. This terminal (labelled "PLUG PL-259") may be connected to a disassociated receiver.

(4) A mounting plate, type Mounting Base MT-198/ART-13A, is supplied for mounting the antenna loading unit to the aircraft structure.

f. ANTENNA SHUNT CAPACITOR.—Antenna Shunt Capacitor CU-24/ART-13 is supplied for use with the transmitter. It is used whenever required (see section II, paragraph 6b(2)(jj)), to properly tune and deliver power to fixed aircraft antennas (20 to 60 feet long) operating in 2000 kc to 3000 kc range of transmission frequencies. The shunt capacitor unit consists

of three individual 25 micromicrofarad capacitors mounted on a plate which serves as a common connection to one terminal of each unit. The terminal at the top of each capacitor may be connected individually or collectively to the antenna system, thus providing capacitance values of 25, 50, or 75 micromicrofarads.

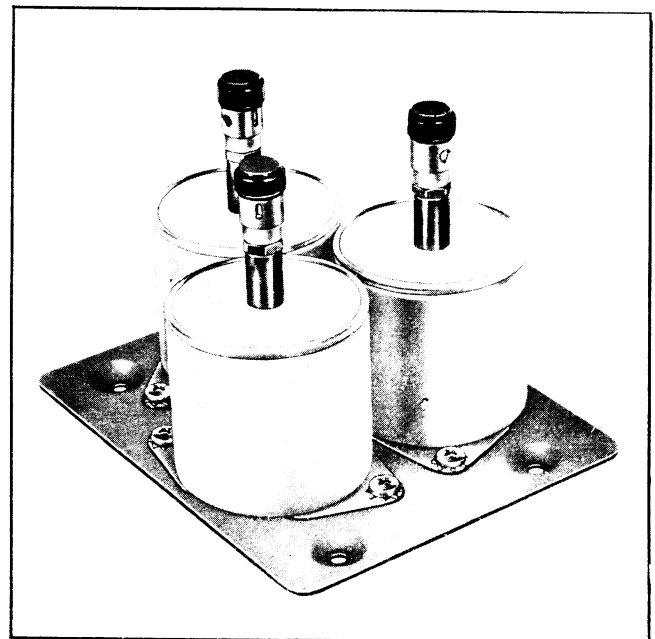

Figure 1-8. Antenna Shunt Capacitor CU-24/ART-13

Mounting holes are provided in the base of this unit to facilitate attachment to the aircraft structure.

8. SIMILAR EQUIPMENT.—Equipment similar to Radio Transmitting Set AN/ART-13 was purchased before procurement of the latter. This equipment, known as Radio Transmitting Set AN/ART-13, ATC, or ATC-1 Aircraft Radio Transmitter in its various models, is substantially the same as Radio Transmitting Set AN/ART-13A, especially after accomplishment of Technical Order modifications. See table 1-6 for details.

4. INTERCONNECTION OF RADIO TRANSMITTING SET AN/ART-13A WITH RADIO RECEIVING SET AN/ARR-11 TO FORM COMPLETE RADIO SET AN/ARC-8.

The complete Radio Set AN/ARC-8 includes the radio receiver. The receiving equipment is interconnected with the transmitting equipment so that they are co-ordinated for "break-in" operation. The radio receiver can be operated when the radio transmitter is either OFF or ON provided that neither the telegraph key nor microphone switch is depressed. It is impossible for the radio transmitter and receiver to be operative at the same time except for receiver calibration

purposes when a "NORMAL-MONITOR" switch is used. When the keying relay in the radio transmitter is actuated, it causes the transmitter to function and at the same time it open-circuits the receiver screen voltage supply, disconnects the receiver antenna, and grounds the receiver antenna terminal. Only transmitter sidetone will then be heard in the headset. When keying relay opens, transmitter output ceases, receiver screen voltage supply is restored, antenna is reconnected and ground connection is removed. The receiver is then ready for operation.

Figure 8-43 illustrates the interconnection of the Radio Transmitting Set AN/ART-13A with Radio Receiving Set AN/ARR-11, Antenna Equipment AN/ARA-4, and terminal panel for the Aircraft's Interphone system. The equipment shown in this illustration constitutes the complete equipment of Radio Set AN/ARC-8. A detailed description of all cables (wire sizes and points of connection) and required plugs is given in the tabulation at the side of figure 8-43. The required plugs are shown in greater detail in figure 8-33.

5. INTERCHANGEABILITY OF MAJOR UNITS.

Although the contents of this book apply specifically to Radio Transmitting Set AN/ART-13A, the same

TABLE 1-6. INTERCHANGEABILITY OF MAJOR UNITS

<i>Name of Unit</i>	<i>Type Designation of USAF Item</i>	<i>Type Designation of Navy Item</i>	<i>Interchangeability</i>
Radio Transmitting Set	AN/ART-13A	AN/ART-13, Navy ATC and Navy ATC-1	See individual components.
Radio Transmitter	T-47A/ART-13	T-47/ART-13	Electrical and mechanical
Dynamotor Unit	DY-17/ART-13A	DY-11/ART-13 and DY-12/ART-13	Electrical and mechanical
Control Unit	C-87/ART-13	C-87/ART-13	Identical
Control Panel	C-405/A	None	No Navy Equivalent
Antenna Loading Unit (200 to 600 Kc.)	CU-32/ART-13A	CU-25/ART-13 plus SA-22/ART-13	Electrical
Antenna Loading Coil (500 to 1500 Kc.)	None supplied	CU-26/ART-13	Item dropped by USAF
Oscillator	O-17/ART-13A (200 to 600 Kc.)	O-16/ART-13 (200 to 1500 Kc.)	Electrical and mechanical
Antenna Shunt Capacitor	CU-24/ART-13	CU-24/ART-13	Identical
Crystal Unit (200 Kc.)	CR-2B/U	CR-2B/U	Identical
Mounting Plate (on transmitter)	MT-283/ART-13	MT-283/ART-13	Identical
Mounting Base (on transmitter)	MT-284 ART-13*	MT-284 ART-13*	Identical
Mounting Plate (for control unit)	MT-163/ART-13	MT-163/ART-13	Identical
Mounting Plate (for dynamotor unit)	MT-164/ART-13	MT-164/ART-13	Identical
Mounting Base (for loading unit)	MT-198/ART-13A	None for load unit; FT-142 for SA-22/ART-13	CU-25 and CU-26 mounted directly
Switch	SA-46/ART-13A	None supplied	SA-46 can be used with either
Plugs	U-6/U — U-12/U	U-6/U — U-12/U	Identical

* Denotes MT-284A/ART-13 is interchangeable.

general type of equipment is also employed by the Navy Bureau of Aeronautics as Radio Transmitting Set AN/ART-13. Major units of both equipments are electrically and mechanically interchangeable. Table 1-6 indicates, by name and designation numbers, each of the major assemblies of equivalent equipments used by the different services or of succeeding models of the same equipment. Interchangeability is indicated by the symbol X.

6. ABBREVIATIONS.

Abbreviations of certain radio terms and phrases are used on the control panels of the equipment and in the following sections of this handbook. These terms and their definitions are itemized as follows.

<i>Abbreviation</i>	<i>Term</i>
A-F.....	Audio Frequency
CFI.....	Calibration Frequency Indicator
CW.....	Continuous-Wave Type of Emission
D.C. (or dc).....	Direct Current
1st Multiplier.....	First Radio-Frequency Multiplier Stage
GND.....	Ground (Br. Earth)
H-F Oscillator.....	High Frequency Oscillator (1000 to 1510 Kc.)
L Frequency.....	Low Frequency Band (200-600 Kc.)
L-F Oscillator.....	Low Frequency Oscillator (200-600 Kc.)
Local.....	Using the Controls on the Transmitter; Not Controlled from a Remote Control Unit

<i>Abbreviation</i>	<i>Term</i>
MCW.....	Modulated Continuous-Wave Type of Emission
P.A.....	Power Amplifier
R-F.....	Radio Frequency
Remote.....	Use of Remote Controls (on Control Unit) to Operate the Transmitter
2nd Multiplier.....	Second Radio-Frequency Multiplier Stage
VFO.....	Variable Frequency Oscillator
Voice.....	Voice Modulation of Radio-Frequency Carrier
XTAL.....	Crystal-controlled
T.S.....	Throttle Switch

7. SYMBOL DESIGNATIONS.

All component parts of Radio Transmitting Sets AN/ART-13A and AN/ART-13B are identified in this manual by means of a symbol designation. These symbol designations appear in the text of the following sections, in illustrations, photographs, schematic circuit diagrams and in the parts list section. Thus a part shown in an illustration can be located in the parts list by means of the symbol designation. Complete descriptions of parts as well as the stock numbers and manufacturer's part numbers appear in the Table of Replaceable Parts (section VII) of this manual.

**SECTION II
INSTALLATION AND ADJUSTMENT**

1. UNCRATING.

Open packing crates as outlined below. Use care to avoid damage and search all packing material to be sure that small packages are not overlooked. All crates are marked with arrows to indicate the upright position. Cut and remove banding around crates.

a. TRANSMITTER.—Keep in upright position and open the carton. Take off waterproof and foil bags. Lift the transmitter out.

b. DYNAMOTOR CRATE.—Keep in upright position and remove cover of crate. Remove waterproof and foil bags. Remove two clamps holding dynamotor to base and lift out the dynamotor. Remove Kimpak wrapper.

c. CONTROL UNIT.—Remove cover of crate. Lift out cardboard carton containing the unit. Remove unit from carton.

d. ANTENNA LOADING UNIT.—Remove cover of crate. Remove foil and waterproof bags.

e. ANTENNA SHUNT CAPACITOR.—Remove cover of crate. Lift out cardboard carton containing the unit. Remove unit from carton.

2. PREPARATION FOR INSTALLATION.

The equipment should be checked before installation to make sure that all parts are operating properly and that no damage occurred during shipment which might cause early failure in service.

a. MECHANICAL INSPECTION.

(1) TRANSMITTER.

(a) Rotate all switches on the face of the transmitter to see that they operate freely and the knobs are fastened tightly to their shafts.

(b) Inspect the terminals at the left end of the transmitter for proper spring action and broken parts.

(c) Inspect the case and mountings for dents or bent portions which might interfere with operation.

(d) Make sure the crystal is in the proper position and clamped securely in place. See Tube Placement Diagram, figure 2-1.

(e) Make sure all tubes are mounted securely in the sockets and that tubes JAN-811, JAN-1625, and JAN-837 are locked properly. See Tube Placement Diagrams, figures 2-1 and 2-1A.

Section II
Paragraph 2

T. O. 12R2-2ART13-2

(f) Make sure the plate connector caps on all tubes employing them are in the proper position and firm.

(g) Remove the cover from the low frequency oscillator and check the tube for proper seating in the socket and firm and proper connection of the plate cap. Replace the cover.

(b) Check the vacuum switch to be sure it is not broken.

(2) DYNAMOTOR UNIT.

(a) Check the fuse and spare fuse to see that they are not blown.

(b) Remove the bottom plate and check all relays and stand off insulators for broken parts.

(c) Check the relays by closing them by hand to see that they do not bind and are not bent.

(d) Make sure all circuit elements are mounted securely. Replace the bottom cover.

(e) Make sure the end cover mounting bolts are tight.

(3) CONTROL UNIT.

(a) Turn the switches to make sure they function properly and the knobs are not loose on the shafts.

(b) Press the key to check the spring action and make sure the mechanism does not bind and stick.

(c) Remove the back plate and inspect the switches for broken parts. Replace the plate.

(4) CONTROL PANEL.

(a) Turn the switches to make sure they function properly and the knobs are not loose on the shafts.

(b) Inspect the switches for broken parts.

(5) ANTENNA SHUNT CAPACITOR.

(a) Inspect to see that no parts are bent or broken.

(b) Check spring action of all terminals.

(6) ANTENNA LOADING UNIT.

(a) Turn the switches to make sure they function properly and the knobs are not loose on the shafts.

(b) Check all terminals for broken parts and spring action.

(c) Remove the cover plate and inspect all switches for broken parts.

(d) Rotate the variometer and make sure it does not bind.

(e) Make sure vacuum switch is not broken.

(f) Make sure micalex terminal boards are not broken.

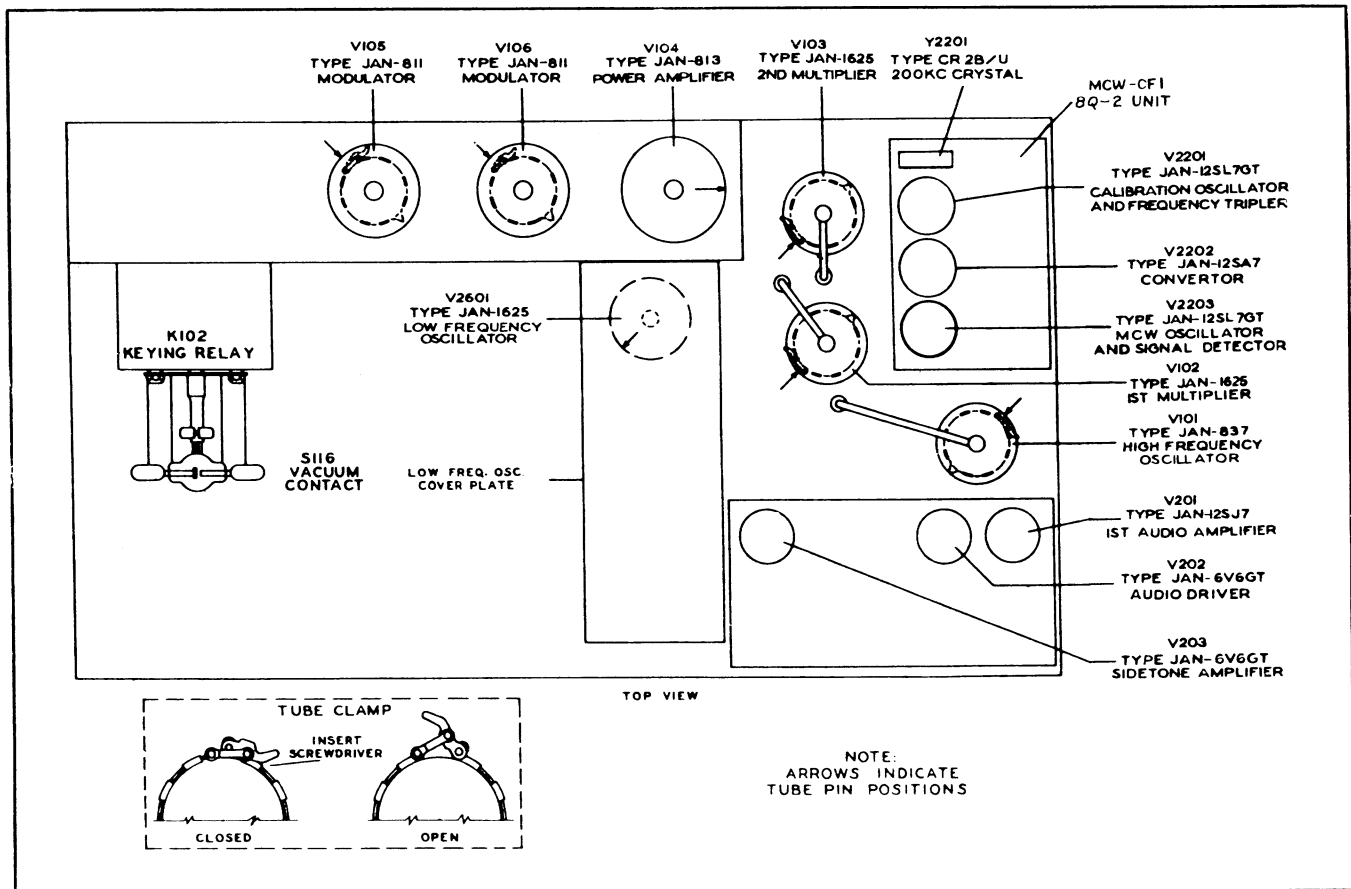

Figure 2-1. Tube Replacement Diagram

(g) Check all stand off insulators to see that none are broken and replace the cover.

b. BENCH TEST.

(1) GENERAL.—Check the complete equipment for proper operation before installation in the aircraft. When numerous installations are to be made, it is recommended that a test bench be set up.

Note

Adjustment procedures for the equipment must be thoroughly understood before making any of the following tests. (See par. 6, this section.)

(2) EQUIPMENT REQUIRED.

(a) Complete mock-up including all necessary cables and plugs and one interphone jack box or panel with liaison position connected into the mock-up.

(b) A 28-volt direct current power source with a capacity of 35 amperes per transmitter being tested.

(c) Suitable phantom antenna (Antenna A-58).

(d) Head Set HS-33.

(e) Microphone T-17, or Microphone T-30 with Cord CD-318 or CD-508.

(f) Means for checking continuity. This may be a continuity meter or just a battery and light bulb.

(g) Plug PL-55 with the terminals shorted.

(3) TEST PROCEDURE
MODEL AN/ART-13A.

(a) Connect the components in the bench mock-up with Antenna A-58 connected to the "FIXED ANTENNA" terminal on the antenna loading unit.

(b) Turn "EMISSION" switch to "VOICE" position and "CHANNEL" switch to position 1.

(c) Set the antenna change-over switch on the antenna loading unit on "FIXED ANT." position and the switch on Antenna A-58 on position 4. Set and lock the transmitter controls on 2400 kc (control A on 1) on channel 1 in accordance with the operating instructions for CW operation and using the crystal frequency indicator. Check P.A. GRID meter reading to make certain the grid drive to the final amplifier tube is within limits.

(d) Channel the autotune into channel 1 by moving "CHANNEL" switch to position 2 until the autotune motor starts and then back to position 1. Close "TEST" switch after cycling is completed. The P.A. PLATE reading should be very close to that obtained when the channel was set up.

(e) Plug the shorted Plug PL-55 into T.S. jack and "KEY" jack in turn. Power should be delivered to the antenna in each case.

(f) Lift the calibration chart on the face of the transmitter and make sure that microphone selector switch S201 is in "CARBON" position. (See fig. 2-2.) Turn "EMISSION" switch to "VOICE," plug the microphone into "MICROPHONE" jack, and press

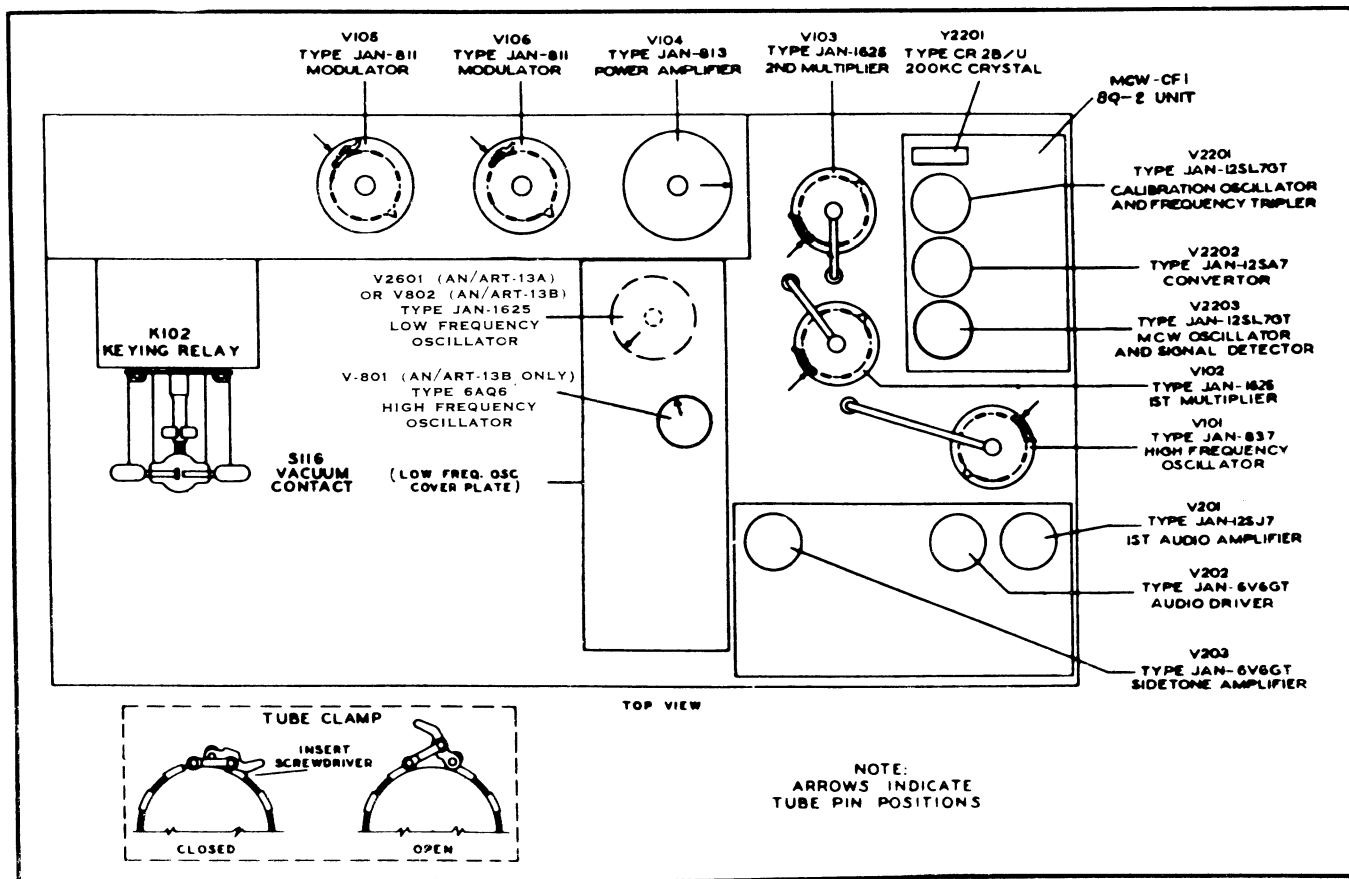

Figure 2-1A. Tube Replacement Diagram AN/ART-13B

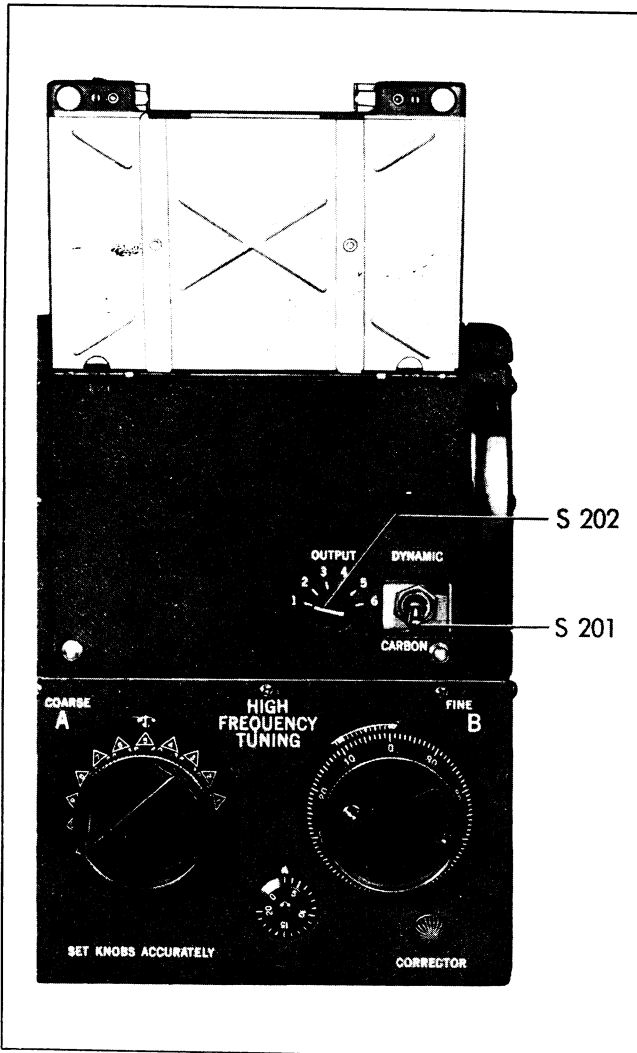

Figure 2-2. Microphone Selector Switch and Sidetone Output Switch

the button. Power should be delivered to the antenna and the plate current should be slightly above that for CW operation. Speak or whistle into the microphone. Plate current should rise near or higher than the MCW area on the meter with modulation.

(g) Place "EMISSION" switch on MCW position and close "TEST" switch. Power should be delivered to the antenna and the plate current meter should read 190 or higher. If this reading is not obtained, readjust the MCW control until a reading of 190 is secured. This adjustment, marked "R2201" in figure 2-3, is located inside the transmitter. See paragraph 7 in the MAINTENANCE section (V) which describes this adjustment.

(h) Listen in the "SIDETONE 1" circuit and key the transmitter on CW, MCW, and modulate on "VOICE" position. The proper sidetone signal should be heard on all emission positions. Repeat with headset connected to the interphone jack box, control box or control panel installed as a part of the mock-up. Lift the calibration chart and set "OUTPUT" switch

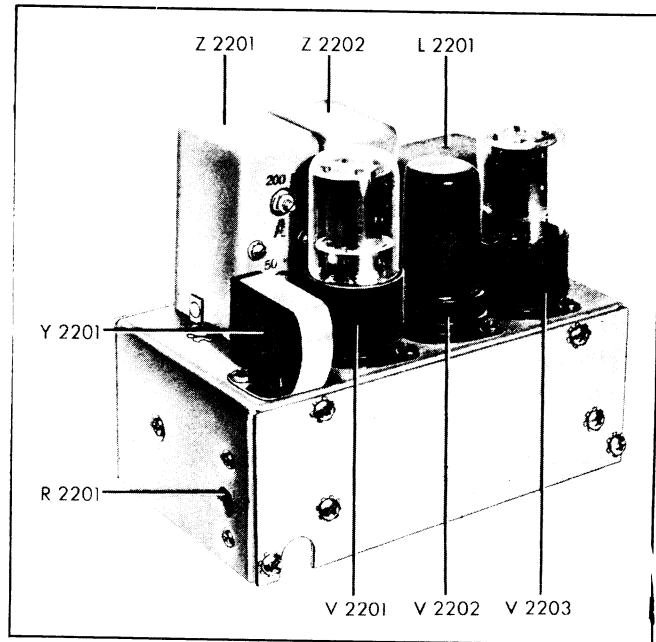

Figure 2-3. MCW-CFI Unit — Top View

S202 on each position in turn. (See fig. 2-2.) The proper sidetone signal should be heard on each position, being louder the higher the number of the switch position.

(i) Set up and lock the other channels of the autotune by loading the transmitter into the phantom antenna, with controls A and B set as follows:

Channel	A	B
2	2	200
3	3	100
4	4	060
5	5	100
6	6	100
7	7	100
8	8	100
9	9	100
10	10	100

(j) Set up the "L.FREQ." channel on 400 kc using the internal CFI.

(k) Place "CHANNEL" switch on "MANUAL," power level switch on "TUNE," meter switch on "P.A. GRID," control B on 100, control C on 13, control A on 11, and close "TEST" switch. The meter should read in or slightly above the lightly shaded area under "P.A. GRID." Repeat with control A on position 12.

(l) Connect all three sections of the antenna shunt capacitor between the "COND" post and ground, and tune the transmitter near 2300 kc. Disconnect the capacitors.

(m) Turn "EMISSION" switch to "OFF."

(n) Change the phantom antenna lead from the "FIXED ANTENNA" terminal on antenna loading unit to the "TRAILING ANTENNA" terminal and set the switch to the "TRAILING ANT." position.

(o) Set "LOCAL-REMOTE" switch on "REMOTE" position, the emission switch on the remote control unit on "VOICE," and "CHANNEL" switch on position 1. Then place the emission switch on CW. Wait for the light on the control unit to come on.

Note

If a control panel is used in the mock-up, disregard the next two steps and check the operation from a microphone connected to the proper terminals for remote operation.

(p) Press the key on the control unit. Power should be delivered to the antenna and the meter should read in the lightly shaded area marked CW. Meter readings should be very close to those obtained previously.

(q) Check "VOICE" and MCW operation from the control unit by means of its emission switch and the microphone jack on it.

(r) Select channels 2 to L.F. on the control unit in turn, closing the key each time the autotune completes cycling. Operation should be normal on each; meter readings, plate and antenna, should be very close to those obtained previously.

(s) Disconnect the wires from the "ANT." and "LOAD COIL" posts and check continuity between the "RECEIVER" post and ground. They should be open with the key up and closed with the key down.

Remove the input plug from the dynamotor unit and then check continuity between the "ANT" and "RECEIVER" posts. They should be connected.

(4) TEST PROCEDURE—MODEL AN/ART-13B.

Note

For VFO operation, using Oscillator O-17/ART-13A, follow instructions as outlined in the preceding paragraph (3) of this section. For crystal-controlled operation, using Oscillator CDA-T, the following instructions are applicable.

(a) Connect the components in the bench mock-up with Antenna A-58 connected to the "FIXED ANTENNA" terminal on the antenna loading unit.

(b) Turn "VFO-XTAL" switch to "XTAL" position, "A-B" switch to "A" position, "EMISSION" switch to "VOICE" position and "CHANNEL" switch to position 1. Set the antenna change-over switch on the antenna loading unit on "FIXED ANT." position and the switch on Antenna A-58 on position 4.

(c) Check control "A" to be sure it is set on channel 1. Unlock control "B", operate the test switch and observe the P.A. GRID meter for grid drive indication. Vary control "B" while observing this meter to obtain maximum reading. Lock control "B". If two crystals are in use for channel 1, adjust control "B" for maximum grid drive reading and note the control set-

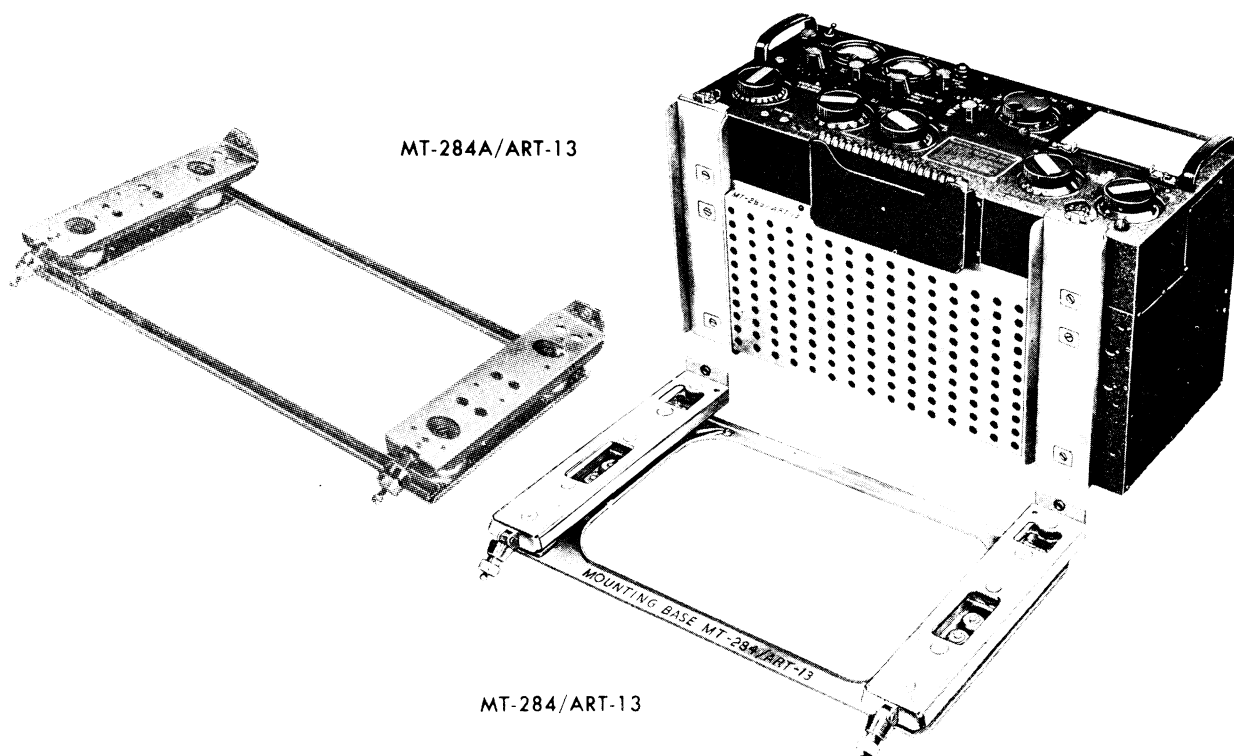

Figure 2-4. Transmitter and Mounting Plate MT-283/ART-13, shown with Mounting Bases MT-284/ART-13 and MT-284A/ART-13

ting. Turn the "A-B" switch to "B" and again adjust control "B" for highest grid drive indication. Finally, set control "B" midway between the two settings required to produce maximum grid drive for each crystal, and lock the control.

(d) With the "A-B" switch in the "A" position, channel the autotune into channel 1 by moving "CHANNEL" switch to position 2 until the autotune motor starts and then back to position 1. Close "TEST" switch after cycling is completed. The P.A. PLATE reading should be very close to that obtained when the channel was set up. Switch to crystal "B". It also should retain the reading previously obtained when the controls were set.

(e) Plug the shorted Plug PL-55 into T.S. jack and "KEY" jack in turn. Power should be delivered to the antenna in each case.

(f) Lift the calibration chart on the face of the transmitter and make sure that microphone selector switch S201 is in "CARBON" position. (See fig. 2-2.) Turn "EMISSION" switch to "VOICE," plug the

microphone into "MICROPHONE" jack, and press the button. Power should be delivered to the antenna and the plate current should be slightly above that for CW operation. Speak or whistle into the microphone. Plate current should rise near or higher than the MCW area on the meter with modulation.

(g) Place "EMISSION" switch on MCW position and close "TEST" switch. Power should be delivered to the antenna and the plate current meter should read 190 or higher. If this reading is not obtained, readjust the MCW control until a reading of 190 is secured. This adjustment, marked "R2201" in figure 2-3, is located inside the transmitter. See paragraph 7 in the MAINTENANCE section (V) which describes this adjustment.

(b) Listen in the "SIDETONE 1" circuit and key the transmitter on CW, MCW, and modulate on "VOICE" position. The proper sidetone signal should be heard on all emission positions. Repeat with headset connected to the interphone jack box, control box or control panel installed as a part of the mock-up.

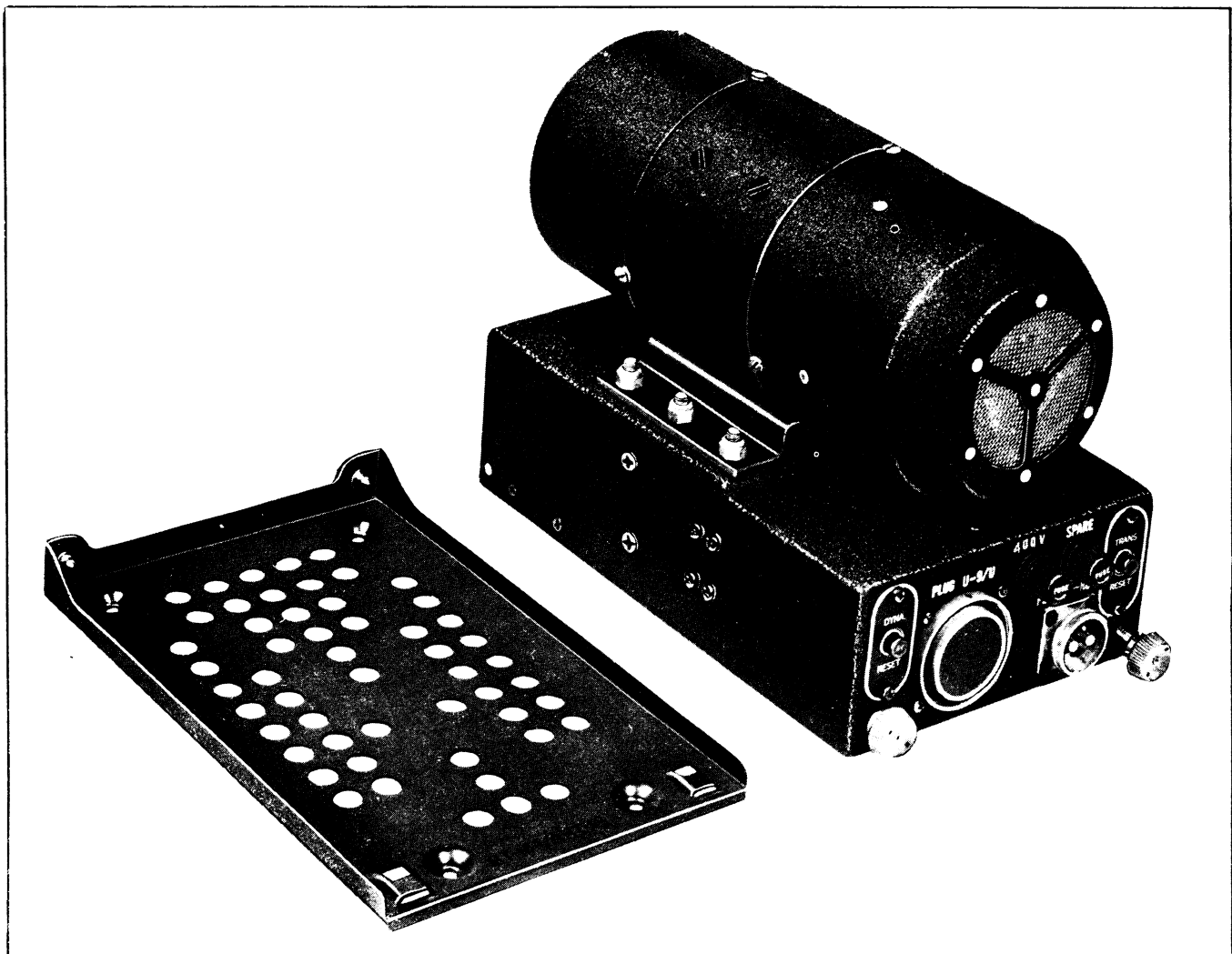

Figure 2-5. Dynamotor Unit DY-17 ART-13A with Mounting Plate MT-164/ART-13

Lift the calibration chart and set "OUTPUT" switch S202 on each position in turn. (See fig. 2-2.) The proper sidetone signal should be heard on each position, being louder the higher the number of the switch position.

(i) Check channels 2 through 10, as outlined in paragraph (4) (a) through (e). It should be understood that "CHANNEL" switch positions will not necessarily correspond with the same position number of control "A". Control "A" has 12 settings available for the high frequency band, and any ten of these settings may be utilized for autotune operation, depending on the crystals in use and the frequency desired.

(j) Turn the "CHANNEL" switch to L.FREQ. When the autotune cycling is complete, control "A" should rest on position 13. Four crystal-controlled frequencies are available, depending on the setting of the 4-position low frequency switch, located on the CDA-T panel. With the four low frequency crystals in place (one holder is a dual crystal type), check for grid drive as previously outlined for the higher frequency ranges. Grid drive may be varied by means of the adjustable plate choke, L803, of the low frequency oscillator tube, V802. This adjustment is readily available from the top of the chassis, at the rear of the CDA-T unit. When more than one low frequency crystal is used, a setting should be selected that will provide sufficient grid drive to obtain normal transmitter output on each crystal frequency.

(k) Crystal operation is not possible using the "MANUAL" setting of the "CHANNEL" switch. This "MANUAL" setting applies only to VFO operation and should be checked as outlined in paragraph (3) (k).

(l) Connect all three sections of the antenna shunt capacitor between the "COND" post and ground. Channel the autotune to a crystal frequency setting near 2300 kc and tune the transmitter. Disconnect the capacitors.

(m) Turn "EMISSION" switch to "OFF."

(n) Change the phantom antenna lead from the "FIXED ANTENNA" terminal on antenna loading unit to the "TRAILING ANTENNA" terminal and set the switch to the "TRAILING ANT." position.

(o) Set "LOCAL-REMOTE" switch on "REMOTE" position, the emission switch on the remote control unit on "VOICE", the "A-B" switch to "A" and the "CHANNEL" switch to position 1. Then place the emission switch on "CW". Wait for the light on the control unit to come on.

Note

If a control panel is used in the mock-up, disregard the next two steps and check the operation from a microphone connected to the proper terminals for remote operation.

(p) Press the key on the control unit. Power should be delivered to the antenna and the meter should read in the lightly shaded area marked CW. Meter readings should be very close to those obtained previously.

(q) Check "VOICE" and MCW operation from the control unit by means of its emission switch and the microphone jack on it.

(r) Turn "A-B" switch on remote control unit to "B". Check again as outlined in preceding paragraphs (4) (p) and (q). Operate the "CHANNEL" switch through positions 2 to L. FREQ., closing the key each time the autotune completes cycling. Operation should be normal on each; meter readings, plate and antenna, should be very close to those obtained previously. In the L.FREQ. position, only one frequency check is possible from the remote position, as the 4-position low frequency switch must be manually operated at the transmitter location.

(s) Disconnect the wires from the "ANT." and "LOAD COIL" posts and check continuity between the "RECEIVER" post and ground. They should be open with the key up and closed with the key down. Remove the input plug from the dynamotor unit and then check continuity between the "ANT" and "RECEIVER" posts. They should be connected.

3. INSTALLATION.

a. TRANSMITTER.

(1) Mount the transmitter at a height convenient for operation of the controls. See figure 8-25 Transmitter Outline Dimensions with Mounting Base MT-284/ART-13 for ventilation provisions, clearances required for operation and removal, bonding, and mounting hole size and placement. The unit may be slid into position from the front or may be lowered on the mounting two inches forward of the final position and slid backwards into position. When the unit has been placed, tighten the two locking knobs on the front edge of the mounting by rotating them clockwise. Tie wire the locking knobs in position.

b. DYNAMOTOR UNIT.

(1) Locate the dynamotor unit in such a position that it will be possible to reach the "RESET" buttons

and the "FUSE" on the front of the unit while in flight. Both ends must be at least three inches from a flat surface to provide sufficient ventilation.

(2) See figure 8-31 Dynamotor Unit Outline Dimensions for plug clearances, bonding, and mounting hole positions and sizes.

(3) To install the dynamotor unit on Mounting Plate MT-164/ART-13, set it on the mounting and slide it backward until the holding pins are engaged, then tighten the two locking knobs on the front of the unit by turning them clockwise. Tie wire the locking knobs together.

c. ANTENNA LOADING UNIT.

(1) Mount Antenna Loading Unit at a height convenient for operation of controls and within easy reach of the transmitter. A clearance of at least 6 inches should be provided between electrical terminals on each side of this unit and surrounding objects.

(2) See figure 8-27 for outline dimensions of Antenna Loading Unit CU-32/ART-13A and figure 8-28 for outline dimensions of Mounting Base MT-198/ART-13A. Required clearances, mounting hole location and bonding instructions are also shown in

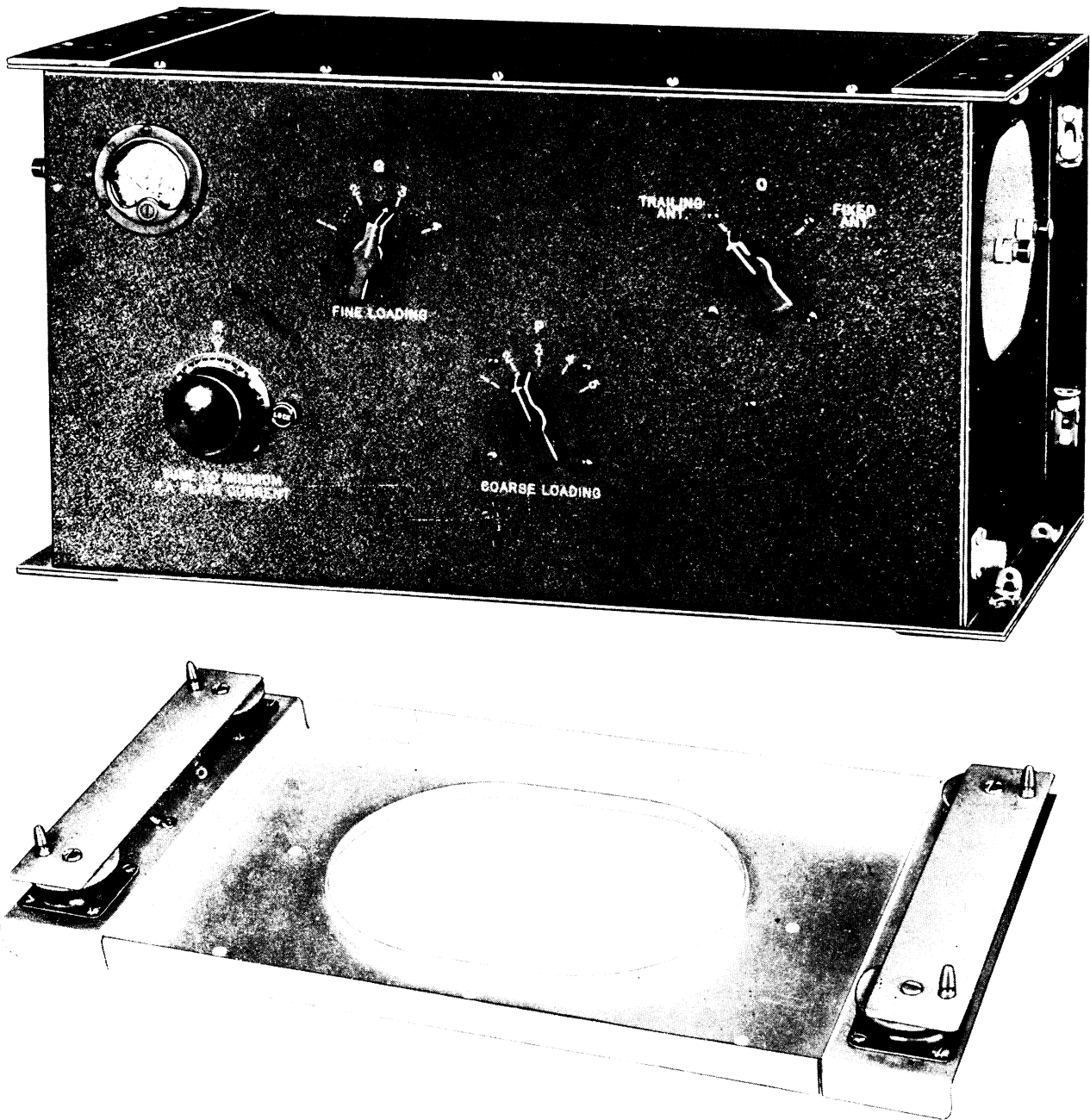

Figure 2-6. Antenna Loading Unit CU-32/ART-13A with Mounting Base MT-198/ART-13A

these figures. The mounting base may be installed on top of, or hung upside down from, a flat surface. Shock mounts must be assembled differently when the loading unit is suspended from the mount. Instructions for proper assembly are shown in figure 8-28. The loading unit may be mounted on top of the mounting base on its top, bottom or back or it may be suspended from the mounting by its top, bottom or back.

(3) Mounting Base MT-198/ART-13A is mounted to the structure of the aircraft by means of four 1/4" screws (see fig. 8-28 for location of holes).

(4) After mounting base has been installed, place loading unit in position on mounting plate and secure by closing all four snap slides (one on each corner of the case). Tie wire the four snap slides.

d. CONTROL UNIT.—Locate the control unit so that the controls are easily accessible to the operator. Mount it with the key upward leaving sufficient space for operation of the key.

(1) See figure 8-26 (Control Unit Outline Dimensions) for plug clearances and mounting hole positions and sizes.

(2) To mount the control unit on Mounting Plate MT-163/ART-13, place the unit on the mounting and tighten the four screws, one in each corner.

e. CONTROL PANEL.—Install the panel in the rack. In racks with threaded holes, mount the panel with screws. In racks with smooth holes and a wire across the center, the panel needs a small adapter plate equipped with quick-release fasteners on each side. A half turn clockwise is all that is necessary to fasten the panel.

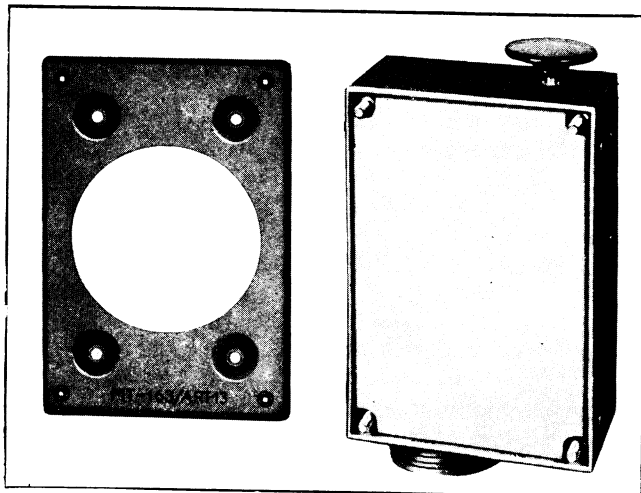

Figure 2-7. Control Unit C-87/ART-13 with Mounting Plate MT-163/ART-13

f. ANTENNA SHUNT CAPACITOR AND SWITCH.

(1) Locate the unit as near the left end of the transmitter as possible. Place between the unit and the

transmitter in such a position that vibration will not cause it to close. The total length of lead from the transmitter to the capacitor shall not exceed 12 inches.

(2) See figures 8-29 and 8-30 for bonding and position and size of mounting holes.

g. OSCILLATOR O-17/ART-13A AND PANEL MX-128/ART-13.—These units are mechanically interchangeable and electrically always maintain the continuity of the filament string. To remove panel MX-128/ART-13 and install Oscillator O-17/ART-13A, proceed as follows:

(1) Remove the top cover and type 813 tube.

(2) Remove the two screws holding the rear of the installed unit to the fire wall assembly.

(3) Remove the seven screws around the front panel of the unit.

(4) Disconnect the lead to the multiplier section as required.

(5) Lift straight up to remove.

(6) Before any attempt is made to install new unit, make certain that the top screws of the autotune cover are loosened on each side of the oscillator panel.

(7) Tilt the low frequency oscillator forward 15 to 20 degrees and install the lower lip of the oscillator panel behind the autotune cover.

(8) Lower the oscillator from its tilted forward position to mate with the Jones plug. Force should not be used to mate these plugs.

(9) When the oscillator is in place, replace and tighten the seven screws that hold the low frequency oscillator panel in place.

(10) Tighten screws along top edge of autotune cover.

(11) Replace and tighten screws that hold the back of oscillator unit.

(12) Replace JAN-813 power amplifier tube and connect plate lead.

(13) Connect one end of wire from standoff insulator (Ref. E-109-B, Figure 8-2) to terminal on right side of oscillator unit.

(14) Replace cover on Transmitter.

b. OSCILLATOR CDA-T.—This unit, used only in Radio Transmitting Set AN/ART-13B, is mechanically interchangeable with Oscillator O-17/ART-13A and Panel MX-128/ART-13 but differs electrically from the latter units. To remove Oscillator O-17/ART-13A and install Oscillator CDA-T, proceed as follows:

(1) Remove the transmitter cover and the type 813 power amplifier tube.

(2) Remove the two screws holding the rear of the installed unit to the fire wall assembly. Replace the type 813 tube.

(3) Remove the seven screws around the front panel of the unit. Loosen the top screws of the autotune

Paragraphs 4-5-6

front cover, on each side of the oscillator panel.

(4) Disconnect the lead from the insulated standoff terminal on the right side of the oscillator unit.

(5) Lift straight up to remove.

(6) Tilt the CDA-T unit forward 15 to 20 degrees and insert the lower lip of the oscillator panel behind the top of the autotune cover.

(7) Lower the oscillator from its tilted forward position to mate with the two Jones connectors. Force should not be used to mate these plugs and receptacles.

(8) When the unit is in place, replace and tighten the seven screws that hold the oscillator in place and tighten screws along top edge of autotune cover.

(9) Remove the low frequency oscillator tube (JAN-1625) in the CDA-T unit. Install screw that holds the back of the oscillator unit to the fire wall assembly. Replace the JAN-1625 tube and connect its plate lead.

(10) Connect the two leads to the standoff insulators on the right side of the CDA-T unit (see figure 8-2A).

(11) Replace cover on transmitter.

4. INTER-UNIT CONNECTIONS.

a. Make up the inter-unit connections when installing the equipment. A drawing of a typical wiring diagram is shown in figure 8-43. Cut the wires to the proper length for the installation involved. Allow enough additional length for each cable so that the radius of any bend in a cable is never less than 8 inches and the cable is not tight enough to interfere with the action of the shock mounts or to damage the connectors. Figure 8-33 shows the dimensions of the plugs and outlines the method of connecting wires to the terminals.

b. Tighten the locking rings on all plugs and tie wire them in place.

5. INSPECTION AND TEST AFTER INSTALLATION.

a. Inspect the inter-connections to check them for conformity to the mock-up of the particular installation. Check the knobs on the front of the transmitter and dynamotor unit, the microphone selector switch under the chart, and all connector plug locking rings for tie wire.

b. Set up the frequencies to be used in the flight test on the channels desired according to the procedure given in the "ADJUSTMENTS" section of this book.

c. Set up one frequency in the range 200 to 600 kc and check it for proper operation.

d. Follow the procedure outlined for DAILY INSPECTION in this Handbook of Maintenance Instructions.

e. Turn on the receiver, make sure the "NORMAL-MONITOR" switch is in the "NORMAL" position,

and listen in the liaison position of the jack box. The receiver hiss should be heard with the key up; the proper transmitter sidetone signal should be heard with the key down. Set the output switch under the calibration chart on the position that gives the proper volume of sidetone signal when the transmitter is being operated.

f. Tune the receiver for CW operation on one of the frequencies set up on the transmitter. Set "NORMAL-MONITOR" switch in "MONITOR" position and close the transmitter key. The transmitter should be on CW. It should be possible to hear a beat note and to tune the beat note to zero by rotating the receiver dial. Release the transmitter key and return "NORMAL-MONITOR" switch to "NORMAL" position.

g. Establish communication with the ground station on each frequency to be used in the flight test.

6. ADJUSTMENTS.

WARNING

Operation of this equipment involves use of high voltages which are dangerous to life. Operating personnel must observe all safety precautions. Whenever the dynamotor is running, there is a potential of 1150 volts applied to the plate caps on top of the tubes.

a. USE OF CALIBRATION TABLES.

(1) In Radio Transmitting Set AN/ART-13A, the low frequency and high frequency oscillators are variable frequency master oscillators (VFO) with no provision made for crystal control of the frequency of either oscillator. Therefore, a crystal controlled frequency standard has been incorporated in the equipment to be used for the calibration of the variable frequency oscillators. Radio Transmitting Set AN/ART-13B uses both crystal-controlled and variable frequency oscillators. These calibration tables are necessary for the VFO operation but are not required for crystal-controlled operation.

(2) Detailed oscillator calibration tables 6-9 and 6-10 are included in section VI, SUPPLEMENTARY DATA, of this book. Calibrating frequency "check points" have been indicated in the calibration tables by printing them in heavy black type. When checking the calibration, it is necessary to use the check point which is numerically nearest to the transmission frequency that is to be used. Heavy ruled lines that appear at intervals in the calibration tables, serve to indicate the direction of the nearest check point. For example—for frequencies that appear above (or before) this dividing line, use first check point (heavy type) that is encountered by looking back to successively lower frequencies. For frequencies that appear below (or after) the dividing line, use first check point (heavy type) that is encountered by looking ahead to successively higher frequencies.

(3) The check points are frequencies at which audio beat notes between the output of the low-frequency oscillator or the output of the high-frequency oscillator and the harmonics of the crystal controlled

50 kc output of CFI unit may be heard. These "beat notes" are used for setting the dial and the movable indicator mark is for adjusting the calibration of the oscillator. The frequency in the tables is given in kilocycles with the control positions in columns opposite the frequency. The numbers in column B or G may be considered as combination numbers. For control G, the hundreds figures (the one or two figures in the third and fourth positions to the left of the decimal point as underlined in the following example: 724.6 or 1536.4) are set on the revolution counter near the control and the rest of the number is set on the dial, estimating the figure to the right of the decimal and setting it between divisions on the dial. For control B, the hundreds figures are set the same as for control G, the two figures immediately to the left of the decimal point (724.6 or 1536.4) are set on the dial and the figure to the right of the decimal point (724.6 or 1546.4) is set by means of a vernier. To obtain the settings given in the columns under B and G (B and G represent both dial designations and calibration table column heading), rotate the control until the revolution counter indicates the proper number of full revolutions and the dial indicates the fraction of a revolution. For accuracy in setting control B, a vernier scale has been provided. To use the vernier, set that part of the number to the left of the decimal point opposite the zero line on the vernier scale. Then note the line on the vernier scale that corresponds to the figure to the right of the decimal point and rotate the dial slightly in a clockwise direction until that line on the vernier is lined up with the first line on the dial that approaches it. For example, opposite 3410 kc the

reading under B in the table is 1114.1. To obtain this setting of control B, rotate the dial until the revolution counter indicates that the control has been rotated 11 full revolutions from the zero setting (see fig. 2-8); then continue to rotate the control until 14 on the dial appears opposite the zero indicating mark, note

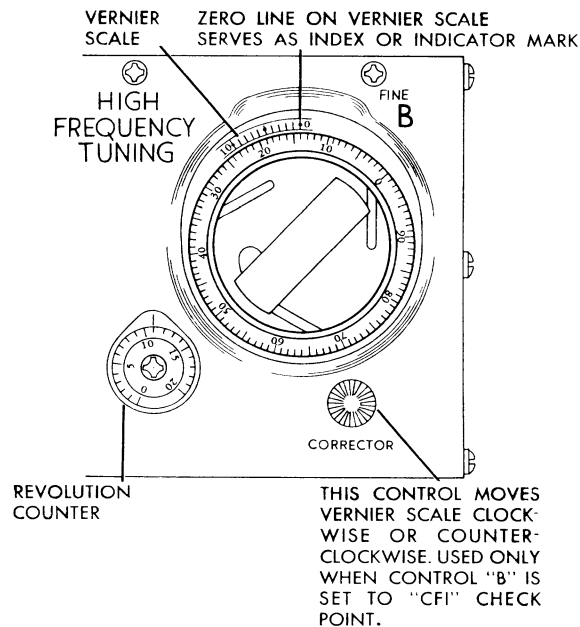

Figure 2-8.
Illustration Showing Setting of Control "B" to 1114.1
(Per Example in the Text)

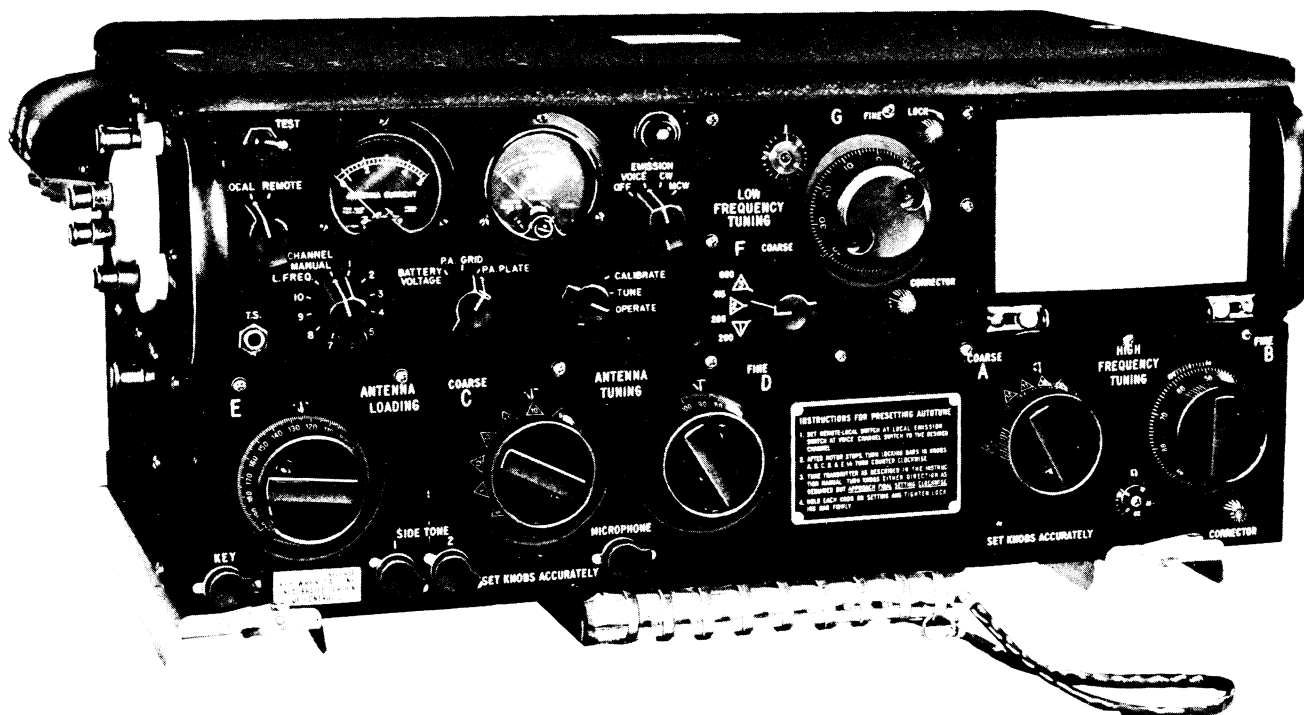

Figure 2-9. Radio Transmitter T-47A/ART-13



Figure 2-9 A. Radio Transmitter T-4 12/ART-13B — Front View

line 1 on the vernier scale and further rotate the dial until the first line (15) on the dial lines up with line 1 on the vernier.

(4) The transmitter can be set to frequencies between those given in the table by the following method:

(a) Find the two frequencies located on either side of the desired frequency.

(b) Find the difference between the dial settings of control B or G for these two frequencies.

(c) Multiply this difference by the decimal of a kilocycle in the desired frequency.

(d) Add this product to the dial setting for the lower frequency in (a).

(e) Example: It is desired to transmit on 3411.5 kilocycles.

	<i>Freq.</i>	<i>A</i>	<i>B</i>	
Desired	3410	3	1114.1	
Frequency	3411	3	1116.6	Difference Between Dial Settings Is 2.4
	3412	3	1119.0	
	3413	3	1121.5	

Setting for desired frequency is obtained thus:

<i>Difference in Dial Settings—</i>	2.4	<i>Multiply</i>
<i>Decimal in the Desired Frequency—</i>	<i>x .5</i>	
	<hr/>	
	<i>Product—</i>	1.20
<i>Dial Setting for Lower Frequency—</i>	1116.60	<i>Add</i>
	<hr/>	
<i>Dial Setting for Desired Frequency—</i>	1117.80	

b. PROCEDURES FOR SETTING THE CONTROLS OF RADIO TRANSMITTER SET AN/ART-13A (MANUAL OR AUTOTUNE OPERATION)

(1) GENERAL.—The following procedures are for setting up the transmitter for “MANUAL” or autotune operation. If “MANUAL” operation is desired it is only necessary to set “CHANNEL” switch on “MANUAL” position and follow these instructions, except the locking bars should not be moved. “MANUAL” operation will not interfere with any of the channels set up for autotune operation if the locking bars are not loosened, nor will setting up any channel in accordance with the following procedure interfere with any other channel previously set up. Channeling the autotune with the locking bars loose will completely eliminate the settings previously set up for the channel that was cycled and may cause settings for some or all of the other channels to shift.

(2) “CW” OPERATION INTO FIXED ANTENNA (2000 to 18100 KC).—The following procedure is to be used for setting up the transmitter for autotune operation on a desired frequency on any one of the 10 high-frequency channels.

(a) Place the antenna selector switch on the antenna loading unit on “FIXED ANT.” position.

(b) Make certain that the microphone, key, and throttle switch (T.S.) jack circuits are open.

(c) Place “LOCAL-REMOTE” switch in “LOCAL” position.

(d) Place “EMISSION” switch in “VOICE” position.

(e) Check primary voltage by moving the meter switch to "BATTERY-VOLTAGE" position. Usable primary voltage is indicated when the meter needle is within the light shaded area under "BATTERY." A primary voltage of 28 volts will cause the meter needle to read at the top edge of this shaded area. A primary voltage of 24 volts will cause the meter needle to read at the lower edge of this shaded area.

(f) Place "CHANNEL" switch in the position corresponding to the channel it is desired to set up. (If "MANUAL" operation is desired, place "CHANNEL" switch in "MANUAL" position.) If the autotune system begins to run, allow it to complete the cycle of operation before proceeding. The red pilot light on the front of the transmitter will light when the autotune cycle is completed, and the transmitter will be ready for tuning adjustments or operation.

Proceeding. See note in paragraph 6b(2)(m), this section.

(s) Place the meter switch on "P.A. PLATE" position.

(t) Place control "D" on zero.

(u) Hold "TEST" switch closed and rotate control "E" throughout its range, seeking a plate current dip indicating resonance of the circuit.

CAUTION

Do not move control "E" across the space between 100 and 200 or between 0 and 100 while "TEST" switch, microphone button, or key is closed. An internal switch will be damaged if this precaution is not followed.

(v) If no resonance dip is found, set control C on the next higher position and rotate control E again, seeking a dip in plate current.

(w) Repeat the instructions in paragraph (v), above, until the resonance dip is found or until control C is set on position 8 and resonance has not been

(l) Set the power level switch to "CALIBRATE" position and listen in the sidetone circuit for a beat note while rotating control B back and forth about the position given for the crystal check point. Set control B on the position that gives zero beat and turn the power level switch to "TUNE" position.

(m) Set the movable indicator mark by means of the "CORRECTOR" knob near control B to the reading of control B found in column B at this crystal check point.

(n) Refer to the calibration table and obtain the correct setting of control "B" for the desired operating frequency.

(o) Set control B to the reading obtained above.

(p) Lock control A by first noting its reading, rotating dial counterclockwise one-quarter turn, or against the stop if the stop is within one-quarter turn, and then rotating it *clockwise to, but not past* the reading on which it had been set. Hold the knob and turn the locking bar clockwise until it is tight with a firm but not heavy pressure. Repeat this procedure for con-

trol B. Further pressure on either control in a clockwise direction should not cause the dial to move beyond the original setting. If it does, unlock and repeat the locking procedure, making certain the original dial settings are used. (If "MANUAL" operation is being used, the locking bars should not be bothered.)

(q) Place "EMISSION" switch on "CW" position.

(r) Check the grid drive to the final amplifier by placing the meter switch on "P.A. GRID" position, closing "TEST" switch, and noting the reading on the meter. It should read in, or slightly above, the light-shaded area marked "P.A. GRID." If it does not, operation is not normal. Control A may not have been positioned accurately or there may be something wrong with the transmitter. Check the trouble before proceeding. See "Note" in paragraph 6b(2)(i).

(g) Unlock all five controls by holding the locking bar 1/4 turn in clockwise direction. (If "MANUAL" operation is being used, the locking bars should not be touched.)

(b) Set control "C" on position 1. The position of the control against the indicator mark on the transmitter panel. *The setting of this control is critical.* The transmitter will not operate if control "C" is not set properly.

(i) Find the desired frequency in the calibration table and note the nearest crystal check point in heavy black type.

(j) Set control A to the position corresponding to the number in column A at this crystal check point. Check the position of the control against the indicator mark on the transmitter panel. *The setting of this control is critical.* The transmitter will not operate if control A is not set properly.

(k) Set control B to the position corresponding to the number in column B at this crystal check point.

Note

If frequency of operation is below 3000 kc, see instructions in paragraph 6b(2)(jj), this section.

(x) If resonance was found on position 1 to 7, inclusive, on control C, place the power level switch in "OPERATE" position.

(y) Load the power amplifier by increasing the reading on control D in steps, re-resonating with control E each time. When control D had been rotated throughout its range, set control C on the next higher position, control D on zero and repeat. Continue this process until the resonance dip falls in the light-shaded area marked "CW" on the plate meter. Correct loading of the final amplifier tube, when a 28-volt primary voltage is used, is 100 on the plate meter. It may not be possible in all cases to load the amplifier tube exactly to this value, but any value of loading which is in the light-shaded area marked "CW" will be satisfactory.

Note

If the resonance dip causes the plate current to fall to a very low value, control C may be set to the next higher position without moving control D, always re-resonating with control E each time as before. Fine adjustment must still be made by means of control D. On antennas less than 55 feet in length and on frequencies below 3000 kc, it may not be possible to load the final amplifier to the light-shaded area marked "CW" before control E reaches zero. If this happens, set control E on zero and resonate with control D. This will give the best operation obtainable under these conditions.

(z) If resonance was not found before control C was set on position 8, leave control C on position 8, set control E on zero, and seek the resonance dip in plate current by rotating control D throughout the range of 0 to 100.

(aa) If resonance is not found, set control C on the next higher position, rotate control D again, seeking the resonance dip.

(bb) Repeat paragraph (aa), above, until resonance is found or until control C has been tried on position 13 without finding a resonance dip.

(cc) If the resonance dip was not found with control C on position 13, leave that control on position 13, place control D on 100, and seek the resonance dip with control E.

(dd) When resonance is found, place the power level switch on "OPERATE" position.

(ee) Load the power amplifier by increasing the reading on control E in steps, re-resonating with control D each time until the resonance dip falls in the light-shaded area marked "CW" on the meter.

(ff) After proper loading of the final amplifier tube has been found using any of the above procedures, lock control C by noting its reading, rotating the dial counterclockwise about one-quarter turn, and then rotating it *clockwise to, but not past* the reading on which it had been set. Hold the knob and turn the locking bar clockwise, until tight, with a firm but not heavy pressure. Further pressure on the dial in a clockwise direction should not cause the dial to move beyond the original setting. If it does, unlock and repeat the locking procedure, making certain the original dial setting is used. Repeat this procedure with controls D and E. (If "MANUAL" operation is being used, the locking bars should not be bothered.)

(gg) Check tuning and locking by holding "TEST" switch closed while placing a small force on *each* dial in turn in the clockwise direction. If all dials are locked properly, no detuning will result. (Do not use this test when in "MANUAL" position.)

(hh) Repeat the above procedure for each high-frequency autotune channel it is desired to set up on the transmitter.

Note

The "P.A. GRID" meter reading, with control A on position No. 7, is usually at the lower edge of the light-shaded area. It is permissible for the grid meter reading for this particular setting (control A on No. 7) to be 50 on the meter scale and still be satisfactory. A lower meter reading is not satisfactory, and the transmitter should be repaired or aligned according to the instructions in section V of this handbook. If control A is not set accurately it is possible for some of the multiplier switches to be between contact positions; this results in loss of grid drive to the final amplifier tube, and burning of contacts. *Set control A accurately.*

(ii) When operating in the 2000-kc to 3000-kc range into a fixed antenna, care must be exercised to avoid operation on a harmonic of the desired frequency. This will be avoided in most cases by following the outlined procedure for tuning adjustment into a fixed antenna. However, for frequencies between 2000 kc and 3000 kc on antennas shorter than approximately 50 feet, the antenna may be too short for the tuning elements in the transmitter to resonate at the fundamental frequency. Therefore, the first resonance indicated by the tuning adjustment may be a harmonic of the desired frequency. To determine whether this is true, follow the tuning procedure outlined in paragraph (jj), below.

(jj) For operation into short antennas (less than 50 feet) at frequencies between 2000 kc and 3000 kc, it may be necessary to connect the antenna shunt capacitor to the "COND." post on the transmitter. This is accomplished by throwing the knife switch so the capacitors are connected to the transmitter. Table 2-1 may be used as a guide to determine whether or not use of the capacitor will be necessary and, if used, how

TABLE 2-1. USE OF ANTENNA SHUNT CAPACITOR WITH ANTENNAS OF DIFFERENT LENGTHS

Length of Antenna (in feet)	Frequency Range (in kilocycles)	Antenna Shunt Capacitor; No. of Sections Necessary
60 to 65	2000 to 18100	None
53 to 60	2000 to 2100	One
53 to 60	2100 to 18100	None
45 to 53	2000 to 2100	Two
45 to 53	2100 to 2200	One
45 to 53	2200 to 18100	None
36 to 45	2000 to 2100	Three
36 to 45	2100 to 2200	Two
36 to 45	2200 to 2400	One
36 to 45	2400 to 18100	None
27 to 36	2100 to 2200	Three
27 to 36	2200 to 2400	Two
27 to 36	2400 to 2700	One
27 to 36	2700 to 18100	None
20 to 27	2200 to 2400	Three
20 to 27	2400 to 2700	Two
20 to 27	2700 to 3000	One
20 to 27	3000 to 18100	None

many sections are required for various frequencies and lengths of antenna.

To determine the length of the antenna, measure the total length of wire from the antenna terminal of the transmitter to the extreme end of the antenna (including the length of the lead inside the airplane). If the antenna is a "T," disregard the length of wire in the shorter branch at the top of the "T," or, if the two branches are equal, include the length of only one of them. The tuning procedure for the transmitter, when using the shunt capacitor, is identical to the procedure without shunt capacitors. The use of these antenna shunt capacitors reduces the power output from the transmitter when used on frequencies higher than those which require its use. For this reason, it should not be used unless necessary and only on those channels which require it. This obviously cannot be done if the transmitter is to be operated from a remote position, since no provisions have been made to automatically switch the shunt capacitor in or out. In this case the capacitor should be used only if it is desired to set a channel in the frequency range wherein the antenna cannot be resonated by the tuning elements in the transmitter itself, and it must be left in for all channels regardless of the reduction of power. Only the capacity necessary to tune the lowest frequency used should be connected. This can be done by connecting one, two, or three of the capacitors in parallel, according to the amount of capacity needed. Use the smallest number possible. To determine the lowest frequency that can be tuned with a given number for a particular antenna, proceed as follows:

1. Connect the circuit it is desired to check; that is, either no capacitor connected, one section connected, two sections connected, or three sections connected.
2. Place "LOCAL-REMOTE" switch to "LOCAL" position.
3. Place "EMISSION" switch on "VOICE" position.
4. Place "CHANNEL" switch on "MANUAL" position.
5. Place the meter switch on "P.A. PLATE" position.
6. When the autotune motor stops and the pilot light comes on, set control A on position 2 and control B on 2000.
7. Tune and load the power amplifier according to instructions contained in paragraphs 6.b. (2) (q) thru (y).

Control A	Control B
2.....	1500
2.....	1000
2.....	500
1.....	1500
1.....	1000
1.....	500
1.....	100

8. Attempt to repeat the above tuning and loading procedure with each of the following combinations of setting in turn.

The setting of control E for each successive trial will be lower than for the preceding trial. If one of the above combinations of controls A and B cannot be tuned without going to a "HIGHER" setting of control C than for the preceding combination, place control C on position 1, control D on zero, and control E on zero. Then rotate control B toward a higher reading, while holding "TEST" switch closed, until the plate current shows a resonance dip. Turn the transmitter off and look up the frequency in the calibration table corresponding to the combination of controls A and B found by this process. *This installation of the transmitter, with sections of the antenna shunt capacitor (if used), with this length of fixed antenna wire in this type of airplane, cannot be tuned to any frequency below that obtained by this process.* It may appear that proper operation is obtained by continuing the tuning procedure to "HIGHER" positions of control C, but this results in operation on a harmonic of the desired frequency and will result in complete lack of communication.

(3) CW OPERATION INTO TRAILING ANTENNA (2000 KC TO 18,100 KC).

- (a) Set controls A and B on the desired frequency by following instructions in paragraphs 6.b. (2) (b) through (s).
- (b) Connect the "ANT." post on the transmitter to ground with a lead as short as possible.
- (c) Place control D on zero.
- (d) Hold "TEST" switch closed and rotate control E throughout its range, seeking a plate current dip indicating resonance of the circuit.
- (e) If no resonance dip is found, set control C on the next higher position and rotate control E again, seeking a dip in plate current.
- (f) Repeat the instructions in paragraph (e), above, until the resonance dip is found or until control C is set on position 8.
- (g) If resonance was not found before control C was set on position 8, leave control C on position 8, set control E on zero, and seek resonance dip in plate current by rotating control D throughout the range of 0 to 100.
- (h) If resonance is not found, set control C on the next higher position, rotate D again, seeking the resonance dip.
- (i) Repeat paragraph (b), above until resonance is found or until Control C has been tried on position 13 without finding a resonance dip.
- (j) If the resonance dip was not found with control C on position 13, leave that control on position 13, place control D on 100, and seek the resonance dip with control E.

CAUTION

Do not attempt to load the transmitter.

Note

The above procedure may be accomplished on the ground and controls C, D, and E locked in the positions found for each frequency on which trailing wire operation is desired. Then, during flight, it will be necessary to channel the autotune into the channel on which it is desired to operate; unlock controls C, D, and E and continue with the procedure that follows. Be sure "EMISSION" switch is on CW, power level switch is on "TUNE," and meter switch is on "P.A. PLATE."

(k) When resonance is obtained, *release the "TEST" key* and remove the connection between the "ANT." post and ground and make certain the proper wire is fastened to that post.

(l) Let out the trailing wire to a counter reading 10 higher than that shown in the following table of approximate antenna lengths for the desired frequency.

(m) Hold the "TEST" switch closed and reel the wire in while watching the plate current meter for a resonance dip.

(n) If no dip is found, let the wire out to a reading 20 higher than that indicated in the following table and repeat the reeling-in procedure.

KC	Counter Reading		
	1/4 Wave	3/4 Wave	5/4 Wave
2000	101		
3000	61		
4000	46	150	
5000	38	118	
6000		90	
7000		70	
8000		60	
9000		48	93
10000		41	76
12000			55
14000			44
16000			37
18000			34

(o) When resonance is found, adjust the length of the wire to correspond to minimum plate current and set power level switch on "OPERATE" position.

(p) If resonance was found with control C on positions 1 to 7 inclusive, load the power amplifier by increasing the reading on control D in steps, re-resonating with control E each time. When control D has been rotated throughout its range, set control C on the next higher position, control D on zero, and repeat. Continue this process until the resonance dip falls in the light-shaded area marked "CW" on the plate meter.

Note

If the resonance dip causes the plate current to fall to a very low value, control C may be set to the next higher position without moving control D, always re-resonating with control

E each time as before. Fine adjustment must still be made by means of control D.

(q) If resonance was found with control C on positions 8 to 13 inclusive, load the power amplifier by increasing the reading on control E in steps, re-resonating with control D each time until the resonance dip falls in the light-shaded area marked "CW" on the meter.

(r) Lock controls C, D, and E. (If "MANUAL" operation is being used, the locking bars should not be loosened.)

Note

This channel may be used on trailing wire again without unlocking the dials by cycling the autotune into the channel, placing the power level switch on "TUNE" position, adjusting the antenna length to the position corresponding to minimum plate current if frequency is below 10,000 kc and to maximum antenna current if frequency is above 10,000 kc, and returning the power level switch to "OPERATE" position. Be sure to use the same number of quarter wave lengths as in tuning up.

(s) Trailing wire operation will increase the range of the equipment considerably in the frequency range 2000 to 6000 kc and somewhat in the frequency range above 6000 kc.

(4) CW OPERATION INTO FIXED OR TRAILING ANTENNA (200 KC TO 600 KC).

The following procedure is to be used for setting up the transmitter for autotune or manual operation on a desired frequency in the low frequency channel.

(a) Place the antenna selector switch on the antenna loading unit in the position which selects the desired antenna.

(b) Make certain that the microphone, key and throttle switch (T.S.) jack circuits are open.

(c) Place "LOCAL-REMOTE" switch in "LOCAL" position.

(d) Place "EMISSION" switch in "VOICE" position.

(e) Place "CHANNEL" switch in "L. FREQ." position and wait until the autotune stops.

(f) Unlock controls A and C, place control A on position 13 and control C on position 8, and lock them in place. (If "MANUAL" operation is being used, place control A on position 13 and control C on position 8 without unlocking them.)

Note

If the low frequency autotune mechanism should fail, it is only necessary to switch to "MANUAL" and set control A to position 13 and control C to position 8, since low frequency operation is only a switching proced-

ure. It is possible to set the low frequency position on any of the 11 channels. It is only necessary to lock control A on position 13 and control C on position 8, on the channel it is desired to use as a substitute for the "L. FREQ." position.

(g) Find the desired frequency in the calibration table and note the nearest crystal check point marked in heavy black type.

(h) Set control F to the position corresponding to the number in column F at the crystal check point.

(i) Unlock control G by turning the "LOCK" knob counterclockwise until loose. Then set control G to the position corresponding to the number in column G at the crystal check point.

(j) Set the power level switch to "CALIBRATE" position and listen in the sidetone circuit for a beat note while rotating control G back and forth about the position given for the crystal check point. Set control G on the position that gives zero beat and turn the power level switch to "TUNE" position.

(k) Set the movable indicating mark by means of the "CORRECTOR" knob near control G to the reading of control G found in column G at the crystal check point.

(l) Refer to the calibration table and obtain the correct setting of control G for the desired operating

frequency and set control G to that reading. Lock the dial.

(m) Place "EMISSION" switch on "CW" position.

(n) Check the grid drive to the final amplifier by placing the meter switch on "P.A. GRID" position, closing "TEST" switch, and noting the reading on the meter. It should read in, or slightly above, the light-shaded area marked "P.A. GRID" on the meter. If it does not, check the position of controls A and C.

(o) Place the meter switch on "P.A. PLATE" position.

Note

In certain aircraft an auxiliary plate current meter is located adjacent to the antenna loading unit for convenience in tuning.

(p) Place control P on the antenna loading unit on position 1.

(q) Place control Q on position 1.

(r) Unlock control R and place it on zero.

(s) Hold "TEST" switch closed and rotate control R throughout its range, seeking a plate current dip indicating resonance of the circuit.

(t) If no resonance was found, place control Q on the next higher position, hold "TEST" switch closed, and rotate control R again, seeking the dip in plate current.



Figure 2-10. Antenna Loading Unit CU-32/ART-13A—Front View

(u) Repeat paragraph (t) above until resonance is found or until control Q has been tried on all its positions.

(v) If no resonance was found in paragraph (u) above, set control P on the next higher position, control Q on position 1 and repeat paragraphs (s), (t), and (u) above.

(w) Repeat paragraph (v) above until resonance is found.

(x) When resonance is found, lock control R in the position giving minimum plate current.

(y) This completes the tuning procedure, as there is no provision for exact loading of the transmitter in the frequency range 200 to 600 kc. The plate current may read anywhere between 10 and 120 for normal operation.

(5) VOICE OPERATION.

Note

Voice and MCW operation on *fixed* wire antennas in the 200 kc to 600 kc range is prohibited because the loading unit is not designed to withstand the high voltages generated with modulation under these conditions. Use CW only on "FIXED ANT." in the 200 kc to 600 kc range.

(a) Adjust the transmitter for "CW" operation and place "EMISSION" switch on "VOICE" position. No further tuning adjustments are necessary.

(b) Be sure the microphone selector switch under the tuning chart on the front panel of the transmitter is in the position corresponding to the type of microphone being used.

(c) Press the button on the microphone or in its cord and hold it depressed while speaking. Release it to listen.

Note

When the meter switch is in "P.A. PLATE" position, the meter indicates the sum of the power amplifier and modulator plate currents and will, therefore, read slightly higher on "VOICE" than on "CW." With normal modulation the plate current meter will read in the red area above the "CW" portion and may hit the meter peg with heavy modulation during normal operation.

(6) "MCW" OPERATION.

Note

Voice and MCW operation on *fixed* wire antennas in the 200 kc to 600 kc range is prohibited because the loading unit is not designed to withstand the high voltages generated with modulation under these conditions. Use CW only on "FIXED ANT." in the 200 kc to 600 kc range.

(a) Adjust the transmitter for "CW" operation and place "EMISSION" switch on "MCW" position. No further adjustments are necessary.

(b) Key the transmitter for normal operation.

Note

The normal meter reading on "MCW" when the meter switch is in "P.A. PLATE" position, key down, will be in or slightly above the light-shaded area marked "MCW."

(7) ADJUSTMENT OF SIDETONE LEVEL.

(a) Lift the chart on the front panel of the transmitter.

(b) Listen in the headphones while holding the "TEST" switch closed and adjust the "OUTPUT" control for proper volume of signal. Check the volume on each type of emission; "MCW," "CW," and "VOICE."

(8) USE OF CHART ON FACE OF TRANSMITTER.—After the transmitter has been set on the desired channels, enter the readings of controls A, B, C, D, and E, on the chart on the transmitter. Make these entries after the autotune has been channeled into each channel set up and after the operation has been checked. Set the indicating mark for control B with the zero line of the vernier directly above the dial and record the reading of the dial with the indicating mark in that position. This will enable the operator to check the settings even after the movable indicating mark has been adjusted to set up another channel. If the shunt capacitor is necessary on any of the frequencies set up, write the number of sections required following the number of channel in the left hand column. Record the settings of controls F, G, P, Q, and R on the lower line. Set the movable indicating mark on control G directly above the dial to obtain its reading, then record whether P, Q, and R are settings for fixed or trailing antenna in the left hand column in the same position used for indicating sections of the shunt capacitor in the upper lines. To minimize tuning in the air, leave controls P, Q, and R on the positions for fixed antenna operation and record the positions for trailing antenna on the chart or reverse the order if desired. If two frequencies in the range 200 to 600 kc are to be used, one may be set on the controls (F, G, P, Q, and R) and the other recorded on the chart. Which of the above methods is chosen for use of the chart for low frequency operation will depend on tactical considerations.

(9) PREPARATION FOR OPERATION.—This transmitter uses tubes which require at least 30 seconds to warm up before operation. If conditions permit, have the transmitter in readiness for operation by leaving the "EMISSION" switch in "VOICE" position during the entire flight. This is a "standby" condition and eliminates the 30 second delay waiting for the tubes to warm up.

c. SIMPLIFIED PROCEDURE FOR SETTING THE CONTROLS.

(1) GENERAL.—The following procedures are for setting the controls using the approximate dial settings following the calibration tables.

TABLE 2-2. CDA-T CRYSTAL-CONTROLLED OSCILLATOR/MULTIPLIER OPERATION

"A" DIAL POSITION	V-801 — High Freq. Oscillator		V-102 — 1st. Mult.		V-103 — 2nd. Mult.		Output Frequency Range (Kc)
	"A-B" Switch Position	Xtal Frequency Range (Kc)	Xtal Freq.	Frequency Range (Kc)	Xtal Freq.	Frequency Range (Kc)	
1	A or B	1670 - 2400	X 1	1670 - 2400			1670 - 2400
2	A or B	2400 - 3000	X 1	2400 - 3000			2400 - 3000
3	A or B	3000 - 3600	X 1	3000 - 3600			3000 - 3600
4	A or B	1800 - 2000	X 2	3600 - 4000			3600 - 4000
5	A or B	2000 - 2400	X 2	4000 - 4800			4000 - 4800
6	A or B	2400 - 3000	X 2	4800 - 6000			4800 - 6000
7	A or B	2000 - 2400	X 1	2000 - 2400	X 3	6000 - 7200	6000 - 7200
8	A or B	2400 - 3000	X 1	2400 - 3000	X 3	7200 - 9000	7200 - 9000
9	A or B	3000 - 3600	X 1	3000 - 3600	X 3	9000 - 10800	9000 - 10800
10	A or B	3600 - 4000	X 1	3600 - 4000	X 3	10800 - 12000	10800 - 12000
11	A or B	2000 - 2400	X 2	4000 - 4800	X 3	12000 - 14400	12000 - 14400
12	A or B	2400 - 3000	X 2	4800 - 6000	X 3	14400 - 18100	14400 - 18100

TABLE 2-3. VFO—OSCILLATOR/MULTIPLIER OPERATION

"A" DIAL POSITION	V-101 — High Freq. Oscillator		V-102 — 1st. Mult.		V-103 — 2nd. Mult.		Output Frequency Range (Kc)
	S-101 C-101 C-135 Switched	Frequency Range (Kc)	Master Freq.	Oscillator Frequency Range (Kc)	Master Oscillator Freq.	Frequency Range (Kc)	
1	Closed	In	1000 - 1200	X 2	2000 - 2400		2000 - 2400
2	Open	Out	1200 - 1510	X 2	2400 - 3000		2400 - 3000
3	Closed	In	1000 - 1200	X 3	3000 - 3600		3000 - 3600
4	Open	Out	1200 - 1510	X 3	3600 - 4000		3600 - 4000
5	Closed	In	1000 - 1200	X 4	4000 - 4800		4000 - 4800
6	Open	Out	1200 - 1510	X 4	4800 - 6000		4800 - 6000
7	Closed	In	1000 - 1200	X 2	2000 - 2400	X 3	6000 - 7200
8	Open	Out	1200 - 1510	X 2	2400 - 3000	X 3	7200 - 9000
9	Closed	In	1000 - 1200	X 3	3000 - 3600	X 3	9000 - 10800
10	Open	Out	1200 - 1510	X 3	3600 - 4000	X 3	10800 - 12000
11	Closed	In	1000 - 1200	X 4	4000 - 4800	X 3	12000 - 14400
12	Open	Out	1200 - 1510	X 4	4800 - 6000	X 3	14400 - 18100

(2) "CW" OPERATION INTO FIXED ANTENNA (2000 KC TO 18,100 KC).

(a) Follow instructions in paragraphs 6b(2)(a) through (s), this section.

(b) Set controls C, D, and E to the positions indicated in the table of approximate dial settings for the desired frequency. (Table 6-11 in this manual.)

(c) If control C is on position 7 or below:

1. Hold "TEST" switch closed and adjust control E to the position at resonance indicated by the dip in plate current.

2. Place the power level switch on "OPERATE" position.

3. If the plate current meter reading is above the area marked "CW," move control D a few divisions lower and readjust control E for minimum plate current. Repeat until the plate current reading is in the area marked "CW." If the plate current meter reading is below the area marked "CW," move control D a few divisions higher and readjust control E for minimum plate current. Repeat until the plate current reading is in the area marked "CW." *Do not leave the controls on any position other than that at the resonance dip.* Lock controls C, D, and E.

(d) If control C is on position 8 or above:

1. Hold "TEST" switch closed and adjust control D to the position at resonance indicated by the dip in plate current.

2. Place the power level switch on "OPERATE" position.

3. If the plate current meter reading is above the area marked "CW," move control E a few divisions lower and readjust control D for minimum plate current. Repeat until the plate current reading is in the area marked "CW." If the plate current meter reading is below the area marked "CW," move control E a few divisions higher and readjust control D for minimum plate current. Repeat until the plate current reading is in the area marked "CW." *Do not leave the controls on any position other than that at the resonance dip.* Lock controls C, D, and E.

(3) "CW" OPERATION INTO FIXED OR TRAILING ANTENNA (200 KC TO 600 KC).

(a) Follow instructions in paragraphs 6b(4), steps (a) through (o).

(b) Set controls P and Q on the positions indicated in the table of approximate dial settings for the frequency below the desired frequency. Be sure to use the column under the correct length of antenna.

(c) Follow the instructions in the regular procedure starting with paragraphs 6b(4)(s), this section.

d. PROCEDURES FOR SETTING THE CONTROLS OF RADIO TRANSMITTING SET AN/ART-13B (MANUAL OR AUTOTUNE OPERATION)

(1) GENERAL.—Radio Transmitting Set AN/ART-13B employs both variable frequency oscillator (VFO) operation and crystal-controlled (XTAL) operation. When operated as a VFO transmitter, utilizing Oscillator O-17/ART-13A, procedures for setting all controls are exactly as outlined for Radio Transmitting Set AN/ART-13A in paragraph b. of this section. For VFO operation on the high frequency range, with the CDA-T Oscillator in use, the transmitter controls are set as outlined for the AN/ART-13A, with the addition of one operation; that is the setting of the "VFO-XTAL" switch, on the CDA-T panel, to "VFO".

Crystal-controlled operation is obtainable only with use of the CDA-T Oscillator unit, and its "VFO-XTAL" switch turned to "XTAL". "MANUAL" operation is not possible with crystal-controlled operation. All transmitter and loading coil adjustments for crystal-controlled operation (excepting the frequency controls "A" and "B") are performed the same as described in paragraph b. of this section. Crystal-controlled frequency adjustment procedures are as follows.

(2) FREQUENCY ADJUSTMENTS—CRYSTAL CONTROLLED OPERATION.—Since manual control is inoperative with crystal-controlled operation, ten high frequency and one low frequency channels are available with autotune selection. Through use of an "A-B" switch on the CDA-T panel, two frequencies are available on each of the ten high frequency "CHANNEL" switch positions. A 4-position switch, also on the CDA-T panel, permits selection of four low frequencies with the "CHANNEL" switch in the "L-FREQ." position.

(3) HIGH FREQUENCY RANGE.—Utilizing the "A-B" switch, two frequency channels are available on each of the autotune "CHANNEL" switch positions, 1 through 10. Selection of frequencies with the 1670 to 18,000 Kc. range are limited only by the available crystals and the individual range of each setting of the transmitters "A" control. "CHANNEL" switch positions of the autotune mechanism are not restricted to any particular setting of the "A" control and several frequency outputs within a narrow frequency range are possible, providing crystals are available for each channel desired. The crystal frequency used, however, must be suitable for the frequency range of the chosen "A" control setting. Table 2-2 lists the frequency range of each position of control "A" and the crystal frequency required for each of these output ranges.

(a) Place the antenna selector switch on the antenna loading unit on "FIXED ANT." position. Make certain that the microphone, key and throttle switch (T.S.) jack circuits are open.

(b) Place "LOCAL-REMOTE" switch in "LOCAL" position, the "VFO-XTAL" switch in "XTAL" position and the "A-B" switch in the "A" position. Turn the "EMISSION" switch to "VOICE".

(c) Check crystals for proper seating and frequency. Channel the autotune to position 1. When

cycling has stopped, check the frequency range of the control "A" setting, to be sure it is suitable for the crystal employed. If not suitable, change either the crystal or retune control "A" to the proper frequency range setting. Lock this control. Unlock the other transmitter controls; set control "C" to position 1.

(d) Place "EMISSION" switch on "CW" position. Check the grid drive to the final amplifier by placing the meter switch on "P.A.GRID" position, closing the "TEST" switch, and noting the reading on the meter. If no reading, or a very low reading is observed, close the "TEST" switch, at the same time varying the "B" control setting. The grid drive indication will vary as the "B" control setting is changed. Adjust this setting for maximum grid drive reading.

(e) Set the remaining transmitter loading controls, as described in paragraph *b.* to obtain proper P.A. Plate dip indication, and maximum antenna current reading.

(f) Channel the autotune to channel 2, and when cycling starts, turn the "CHANNEL" switch back to position 1. Again check the grid drive and P.A. Plate readings, which should be approximately the same as previously obtained.

(g) Channel the autotune to each of the remaining nine high frequency channels and tune as outlined for channel 1.

(h) If two frequency outputs are desired for any one position of the "CHANNEL" switch, their frequencies should not be separated by more than 3%.

The exact amount of separation possible will be determined by the output frequency and the antenna characteristics into which the transmitter operates. Adjust the setting of control "B" as outlined with the "A-B" switch on "A". Record the setting of this control for maximum grid drive reading. Throw the "A-B" switch to "B" and determine the setting of control "B" for maximum grid drive indication. Finally, set control "B" midway between the two settings obtained with maximum grid drive for the "A" and "B" crystals. Repeat this procedure for all channel switch positions for which two crystals are in use.

(4) LOW FREQUENCY RANGE.—Utilizing the 4-position selector switch, located on the CDA-T panel, four low frequency outputs within the range of 300 to 500 Kc. are possible. It will be noted that only three low frequency crystal sockets are provided, requiring the use of a dual crystal holder in one socket. Due to the physical limitations of this holder, its two crystals must be within the range of 400 to 500 Kc. Remote control of low frequency operation is possible, only on one frequency, as the 4-position switch must be operated manually and its setting will determine the frequency obtained by the remote control operator.

(a) Place the antenna selector switch on the antenna loading unit in the fixed antenna position. Make certain that the microphone, key and throttle switch (T.S.) jack circuits are open. Place "LOCAL-REMOTE" switch in "LOCAL" position, the "EMISSION" switch in "VOICE" position, the "VFO-XTAL"

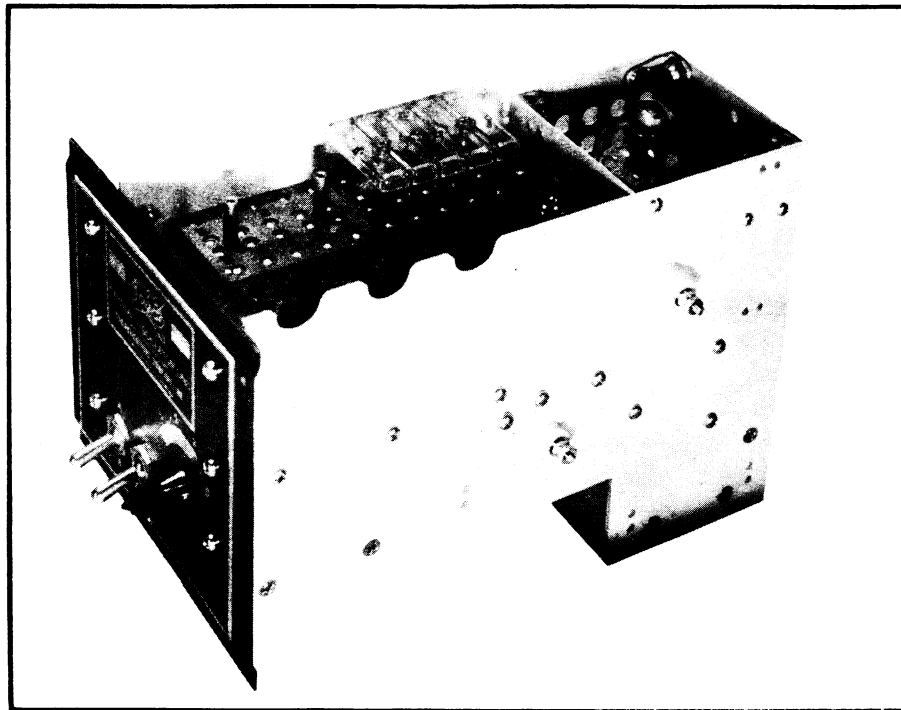

Figure 2-11 Crystal Controlled Oscillator Unit (CDA-T) — Front Side View

switch in "XTAL" position, and the 4-position low frequency selector switch in position 1.

(b) Place "CHANNEL" switch in "L.FREQ." position and wait until the autotune stops. Control "A" should stop on position 13. If not in this position when cycling is complete, unlock control and set to 13. Set control "C" to position 8. (Control "B" is not required for low frequency crystal operation.)

(c) Place the meter switch on "P.A.GRID"; the "EMISSION" switch on "CW", and check for grid drive by closing the "TEST" switch and noting the meter reading. P.A.GRID meter readings will be lower than those obtained for the high frequency ranges.

(d) Adjust the variable choke, L-803, located at the top rear corner of the CDA-T unit, to obtain maximum grid drive indication.

(e) Turn the 4-position switch to the remaining three positions, and check for grid drive. Adjust the variable choke, as required, to obtain maximum grid drive reading for each switch position. This choke setting will vary slightly for each of the low frequency output frequencies, and should finally be set to obtain sufficient grid drive with all crystals employed.

(f) Set all other transmitter and loading coil adjustments as outlined in paragraph b. (4) (o) through (y) of this section, to obtain proper P.A. Plate dip indication and maximum antenna current reading. When more than one low frequency crystal is employed, optimum transmitter performance on any one frequency requires readjustment of the variable choke (for grid drive peaking) and the transmitter loading controls, with a resultant lowering of output at the remaining low frequency channels.

SECTION III OPERATION

CAUTION

No transmissions will be made on emergency (distress) H.F. Channels except for emergency purposes. For testing, demonstration or drill purposes, radio equipment will be operated into a non-radiating dummy load instead of an Antenna to prevent transmission of false distress signals.

WARNING

This equipment utilizes high voltages which are dangerous to life. Operating personnel must observe all safety regulations. Be sure to turn off the entire equipment before opening top cover of transmitter. High voltage (1150 volts) connections are made to the caps at the tops of some tubes.

1. STARTING AND STOPPING THE EQUIPMENT.

a. TO START.—Turn "EMISSION" switch to "VOICE" position.

b. TO STOP.—Turn "EMISSION" switch to "OFF" position.

2. OPERATION DURING NORMAL USE.

a. Check "LOCAL-REMOTE" switch to make sure it is in the proper position according to whether operation is from the transmitter panel or from the remote control unit.

b. Place the emission switch on "VOICE" and "CHANNEL" switch on the position corresponding to the frequency on which transmission is desired. This may be found on the chart on the front panel of the transmitter.

c. When the red pilot light comes on (it will take about 25 seconds for the Autotune to seek the proper position), place the emission switch on the position corresponding to the type of emission desired, either "VOICE," "CW," or "MCW."

Note

Voice and MCW operation on *fixed* wire antennas in the 200 kc to 600 kc range is prohibited because the loading unit is not designed to withstand the high voltage generated with modulation under these conditions. Use CW only on "FIXED ANT." in the 200 kc to 600 kc range.

d. The transmitter is now ready for operation. Use either a key or a standard microphone as required by the type of emission chosen.

CAUTION

Under no circumstances should the transmitter be actually operating (key down or microphone pushbutton closed) when "EMISSION" switch is being operated. Such operation, especially at high altitudes, can cause an arc to occur and damage the contacts of relays.

3. CORRECTIVE MEASURES IF NORMAL OPERATION IS NOT OBTAINED.**a. FUSE OR CIRCUIT BREAKER FAILURE.**

(1) If Autotune does not run and tubes do not light, press the "TRANS. RESET" button on the front of the dynamotor unit.

(2) If Autotune runs and tubes light but dynamotor does not start, press the "DYNA. RESET" button on the front of the dynamotor unit.

(3) If Autotune runs, tubes light, and dynamotor starts but no transmission is obtained, first check the position of control C by unlocking the dial and rotating it back and forth through a small range while holding "TEST" switch closed. If this results in normal operation, lock control C near the proper number but in such a position that the transmitter will operate even if not exactly on the indicated position. If rotating control C does not result in normal operation, check the fuse on the front panel of the dynamotor unit and if it is blown, replace it with the SPARE fuse.

b. REMOTE CONTROL UNIT OR CABLE FAILURE.

(1) Place "LOCAL-REMOTE" switch on the transmitter panel in "LOCAL" position and operate transmitter from its panel.

c. TUBE FAILURES.

(1) **LOW FREQUENCY OSCILLATOR.**—Replace with one of the multiplier tubes. This will provide low frequency operation only.

(2) **ONE MULTIPLIER TUBE.**—Interchange with the low frequency oscillator tube. A tube with a good filament must be in the low frequency oscillator socket at all times. This will provide high frequency operation only.

(3) **TWO MULTIPLIER TUBES OR ONE MULTIPLIER TUBE AND THE LOW FREQUENCY OSCILLATOR TUBE.**—Put the good tube in the first multiplier socket. Tubes with good filaments must be in the low frequency oscillator and the second multiplier sockets. This will provide operation in the frequency range 2000 to 6000 kc.

(4) **SPEECH AMPLIFIER.**—Use "CW" operation. No sidetone signal will be available.

(5) **AUDIO DRIVER.**—Interchange it with the sidetone amplifier. There must be a tube with a good filament in the sidetone socket. This will provide normal operation with the exception of a sidetone signal.

(6) **MODULATOR.**—Use "CW" operation. The modulator tubes must have good filaments.

(7) **DETECTOR AND MCW AUDIO OSCILLATOR.**—Interchange it with the crystal oscillator tube. If there is a tube with a good filament in the crystal oscillator socket, all operation will be normal except the "CFI" will be inoperative. If the tube in the crystal oscillator socket does not have a good filament, only "VOICE" and "CW" operation are possible.

(8) **ANY COMBINATION (INCLUDING ALL) OF CRYSTAL OSCILLATOR, MIXER, DETECTOR AND "MCW" AUDIO OSCILLATOR, SIDETONE AMPLIFIER.**—There must be a tube with a good filament in the sidetone amplifier socket. "VOICE" and CW operation are available.

(9) **ANY COMBINATION (INCLUDING ALL) OF CRYSTAL OSCILLATOR, MIXER, DETECTOR AND MCW AUDIO OSCILLATOR, SPEECH AMPLIFIER, DRIVER, SIDETONE AMPLIFIER, MODULATORS.**—There must be tubes with good filaments in the modulator sockets. CW operation is available.

(10) **HIGH FREQUENCY OSCILLATOR.**—Interchange with the low frequency oscillator. The tube in the low frequency oscillator socket must have a good filament. It may be necessary to reset the frequency of operation since this interchange will cause the oscillator to shift from the original frequency. The tube must be replaced with the proper type as soon as possible. This interchange will provide high frequency operation only.

d. AUTOTUNE FAILURE.—If the Autotune fails to position all dials properly, proceed as follows until proper positioning is obtained.

(1) First turn all controls, that did not position properly, in the extreme counterclockwise direction by hand and then turn them clockwise until they stop.

(2) If that fails, turn "CHANNEL" switch to "MANUAL" and set the controls on the proper position as indicated by the chart on the transmitter and re-resonate by adjusting the tuning control (either D or E) to the plate current dip.

(3) If controls are tight and above procedure fails, loosen the locking bars and set the controls as for "MANUAL" position.

e. ANTENNA LOADING UNIT FAILURE.—Connect the "ANT." post on the transmitter directly to the antenna lead-in. This will provide high frequency operation only.

f. VACUUM SWITCH FAILURE.—Remove the wire from the "ANT." post and connect it to the "COND." post. Add a wire from the "RECEIVER" post on the transmitter to the antenna (either fixed or trailing) not being used for transmission. Be sure the trailing wire is reeled out. This operation may result in damage to the receiver especially if the same frequency is being used for transmission and reception. As a precaution, the wire may be disconnected from the antenna (A) post on the receiver during each transmission period.

g. COLD WEATHER FAILURE.—On certain frequencies where Dial D tunes very sharply, difficulty may be experienced if those frequencies are set up in moderate ambient temperatures and subsequently operated at extremely cold temperatures, or vice versa. This is due to change of inductance with temperature. The condition will occur only in extremes of temperature and can be corrected by resetting Dial D.

SECTION IV THEORY OF OPERATION

1. DESCRIPTION OF OPERATION.

a. GENERAL.—A detailed analysis of the theory and function of all parts of Radio Transmitting Sets AN/ART-13A and AN/ART-13B is presented in this section. Model AN/ART-13B duplicates all functions of Model AN/ART-13A, differing from the latter model by the addition of a crystal-controlled oscillator unit, known as the CDA-T. Any reference to the Model AN/ART-13B or crystal-controlled operation, which does not apply to the AN/ART-13A, will be indicated by a separate paragraph with an appropriate sub-title.

Both equipments are designed to provide radio communication by voice, modulated continuous wave telegraphy, or continuous wave telegraphy employing VFO operation over the frequency ranges 200 kc to 600 kc and 2000 kc to 18,100 kc. In addition to the VFO operation, Model AN/ART-13B provides crystal-controlled operation over the frequency ranges 300 to 500 kc and 1670kc to 18,000 kc. These equipments function as medium power transmitters intended primarily for aircraft use. A distinguishing feature of this equipment is the automatic tuning system known as the "Autotune". By means of the Autotune, the manual functions that are performed to change transmission frequency, can be made automatic and any one of eleven preset transmission channels may be selected. Approximately 25 seconds is required for the Autotune to reset transmitter controls for operation on a new transmission frequency. Remote control of operations required to change the transmission frequency is also made possible with the aid of the Autotune system.

An understanding of the theory and performance of the circuits can be more easily obtained by first examining the contribution made by each major circuit and by following the signal path from origin to the antenna. This can be accomplished by a study of the block diagrams, figures 4-1 and 4-1A; and with the aid of the explanation in the following paragraphs.

b. ORIGIN OF CARRIER FREQUENCY.—The carrier frequency of both transmitters, for VFO operation, is generated in either of two variable frequency oscillators, depending on the transmission frequency that is selected. One oscillator, which covers the range 200 kc to 600 kc is known as the low frequency oscillator, or "LFO Unit". The second VFO oscillator, covering the range of 1000 kc to 1510 kc, utilizes one or more frequency multiplier stages to produce the high frequency range of 2000 kc to 18,100 kc. For crystal-controlled operation (Model AN/ART-13B only), a plug-in crystal unit known as the CDA-T, provides a low frequency output of 300 kc to 500 kc, coupled direct to the Power Amplifier stage and a high frequency out-

put which utilizes one or more of the transmitters frequency multiplier stages to cover a frequency range of 1670kc to 18,000 kc. Tables 2-2 and 2-3 indicate the basic oscillator frequencies for each of the twelve high frequency dial positions, along with the multiplication factors, the frequency multiplier stages used and their frequency output.

(1) VFO OPERATION—MODELS AN/ART-13A AND AN/ART-13B

(a) HIGH FREQUENCY OSCILLATOR AND MULTIPLIER STAGES.—When transmission frequencies in 2000kc to 18,100 kc range are required, the V101 High Frequency Oscillator is used. Output of this oscillator is fed into the First Frequency Multiplier stage where the frequency is doubled, tripled, or quadrupled as required. Further frequency multiplication is required to obtain frequencies above 6.0 megacycles and a Second Frequency Multiplier stage is provided for that purpose. The second multiplier acts only as a frequency tripler and is not used for generation of transmission frequencies below 6.0 megacycles. Thus, for transmission frequencies in the range 2.0 to 6.0 megacycles, the Second Frequency Multiplier is disconnected and the output of the First Frequency Multiplier is fed directly to the Power Amplifier stage. For transmission frequencies in the range 6.0 to 18.1 megacycles, the Second Frequency Multiplier is connected into the system and the output of the First Frequency Multiplier is fed to the Second Frequency Multiplier. Output of the Second Frequency Multiplier is then coupled to the Power Amplifier stage.

(b) LOW FREQUENCY OSCILLATOR.—When transmission frequencies in the 200 kc to 600 kc range are required, the Low Frequency Oscillator is used. Output of this oscillator is fed directly to the Power Amplifier Stage. The High Frequency Oscillator and both multiplier stages are not used.

c. MODULATION.—The carrier frequency may be "keyed" for Continuous Wave (CW) or Tone Modulated Continuous Wave (MCW) emission. Voice modulation may also be accomplished. The three types of emission, CW, MCW, or VOICE are selected by means of a manually operated switch knob on the control panel of the transmitter or the control panel of the Control Unit.

d. FIRST AUDIO AMPLIFIER, AUDIO DRIVER, AND MODULATOR.—When Voice is used, the input from either a carbon or dynamic microphone is coupled to the First Audio Amplifier Stage. Output of the amplifier is fed to the Audio Driver Stage which develops sufficient audio power to "drive" the Modulator Stage. The Modulator Stage is then coupled to

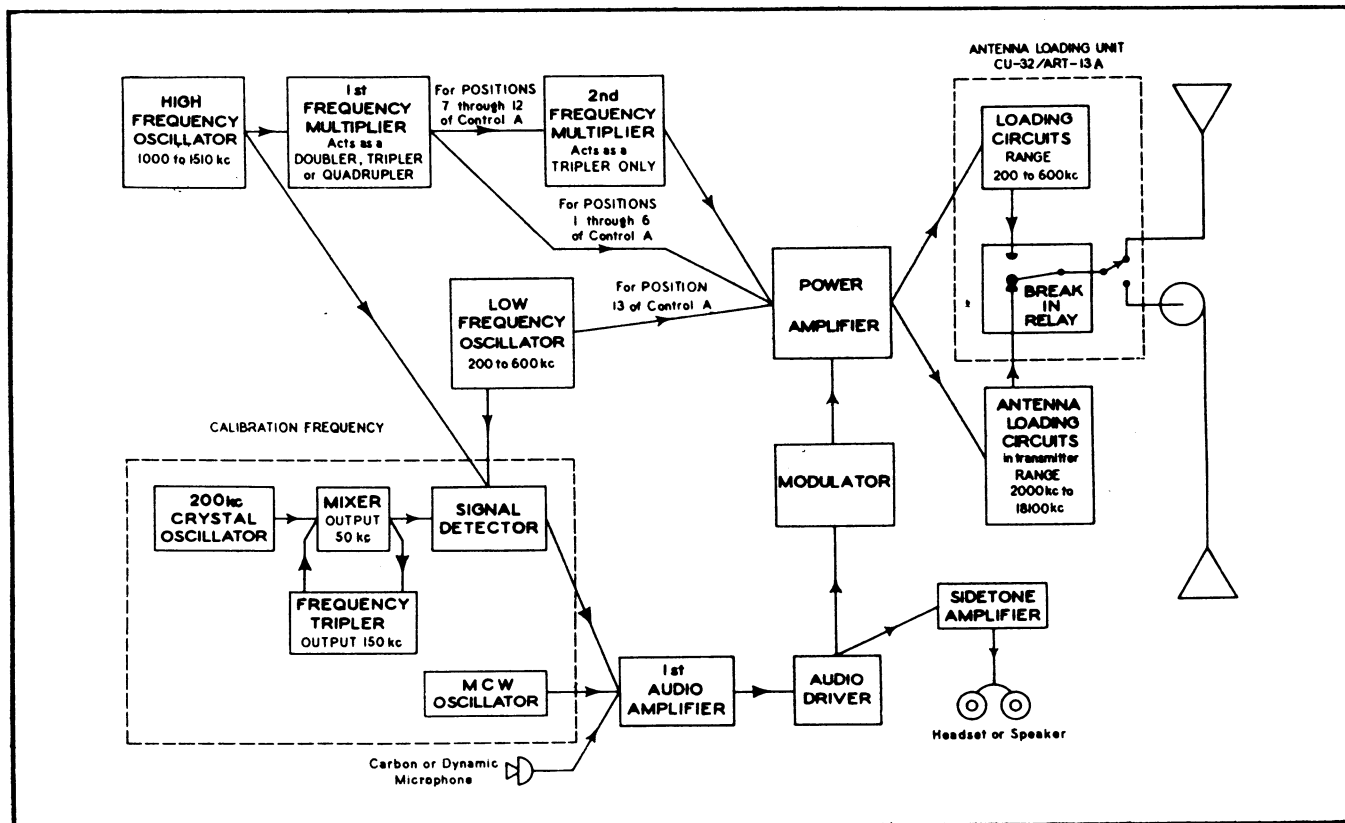

Figure 4-1. Radio Transmitting Set AN/ART-13A — Block Diagram

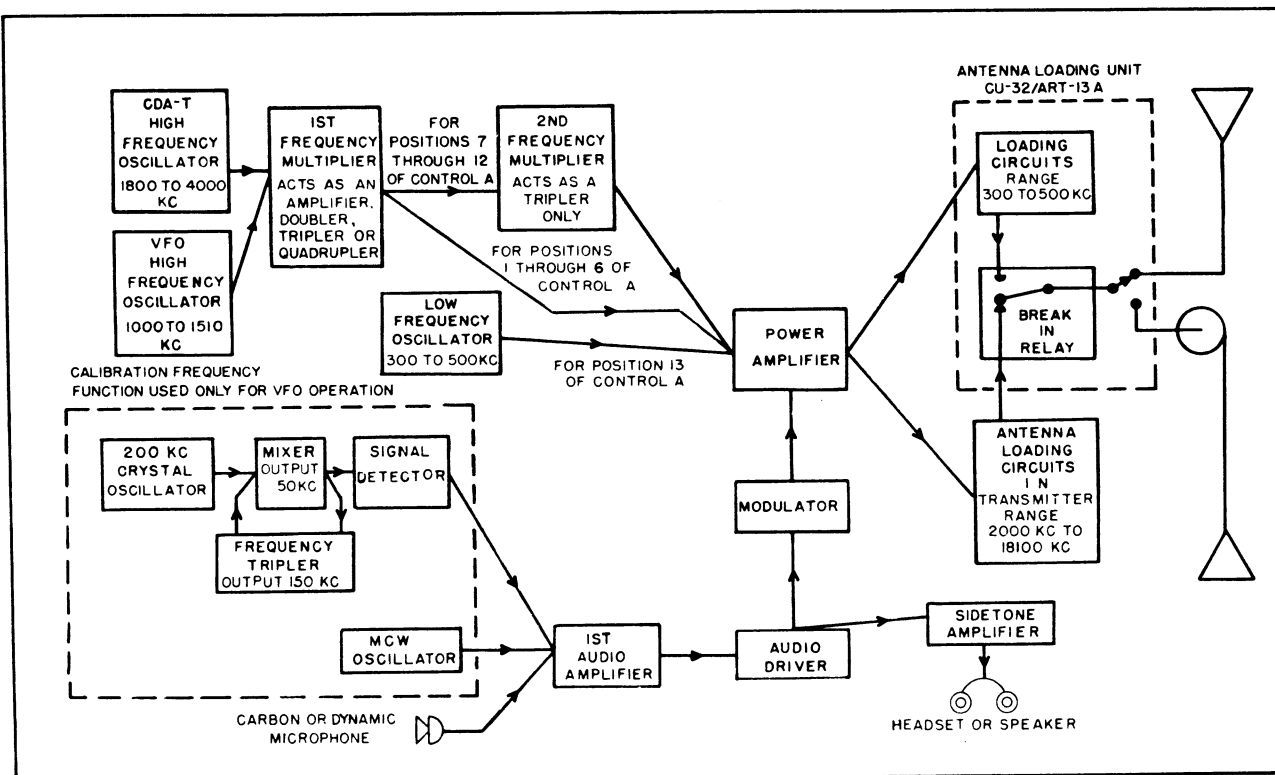

Figure 4-1A. Radio Transmitting Set AN/ART-13B — Block Diagram

the Power Amplifier to accomplish Voice modulation of the carrier.

e. MCW OSCILLATOR.—A separate audio oscillator, known as the MCW Oscillator, is provided to generate approximately a 1000 cycle tone that is used for modulation of the carrier frequency when MCW emission is selected. The output of the MCW oscillator is coupled to the input of the First Audio Amplifier when transmitter is used for CW or MCW emission. This audible tone then passes through Audio Driver Stage, Modulator Stage, and to Power Amplifier to modulate the carrier. (NOTE: When using CW emission, modulator stage is not in operation thus preventing this audible tone from modulating the carrier.) Operation of the telegraph key will "key" the MCW Oscillator as well as the Carrier Oscillator (High or Low Frequency Oscillator) and the Power Amplifier Stage.

f. POWER AMPLIFICATION AND ANTENNA COUPLING.—The Power Amplifier Stage provides for power amplification of the modulated carrier. Output of this stage is connected to an antenna loading circuit where power is delivered to the antenna. Two separate antenna loading circuits are provided. The loading circuits in Radio Transmitters T-47A/ART-13 (AN/ART-13A) and T-412/ART-13B (AN/ART-13B) are used for transmission frequencies in the range 1670 kc to 18,100 kc. A separate unit known as Antenna Loading Unit CU-32/ART-13A is equipped with the loading circuits for transmission frequencies in the range 200 kc to 600 kc. Separate output terminals on the transmitter are used to connect both the low frequency and high frequency output to two separate terminals on Antenna Loading Unit CU-32/ART-13A. The low frequency input connects to the loading circuits within the loading unit. Output from these circuits passes to a "break-in" relay also incorporated in the loading unit. This relay also handles the high frequency output of the transmitter. When transmitter is operated in the 1670 kc to 18,100 kc frequency range, the "break-in" relay in Antenna Loading Unit CU-32/ART-13A is not operated and its contacts provide a closed path for connection of high frequency terminal to the antenna directly. When transmitter is operated in 200 kc to 600 kc frequency range, the relay in Antenna Loading Unit CU-32/ART-13A is operated by the telegraph key or microphone switch. The antenna is then connected to the output of the low frequency loading circuits in the unit; thus permitting power to be delivered to antenna whenever the telegraph key or microphone switch is depressed. When the telegraph key or microphone switch is released, the relay reconnects the antenna to the high frequency antenna terminal of the transmitter. The high frequency antenna terminal of the transmitter is connected to the receiver antenna terminal whenever the telegraph key or microphone switch is released thus providing for "break-in" operation of an associated radio receiving set.

g. ANTENNAS.—The output of the Antenna Load-

ing Unit may be connected to either a Trailing Wire or a Fixed Aircraft Antenna. Two separate antenna terminals are provided. A manually operated switch on the Loading Unit is used to select either antenna.

h. SIDETONE AMPLIFIER.—A portion of the output from the Audio Driver Stage is coupled to a separate audio amplifier known as the Sidetone Amplifier. Output from this amplifier is used to operate the headset or a speaker. The Sidetone Amplifier provides for monitoring the code or voice that modulates the carrier. It also provides a means of listening to the output of the CFI Unit that is used in checking calibration of the high or low frequency oscillators. This action is described more fully in the following paragraph.

i. CALIBRATION FREQUENCY INDICATOR ("CFI") UNIT.—This unit, used only with VFO operation, consists of four major circuits which operate to provide a constant 50 kc signal (rich in harmonics) that is then mixed with output of either the high or low frequency oscillator to produce an audible beat note. Calibration of the carrier frequency oscillator can then be checked at numerous points by "zero beating" the 50 kc standard against the carrier frequency oscillator. A beat note will be heard when the carrier frequency or its harmonics are approximately equal to some harmonic of the 50 kc standard.

j. GENERATION.—Generation of the 50 kc signal in the CFI Unit is accomplished by using a circuit known as a regenerative frequency divider. The circuit produces a 50 kc fundamental frequency and harmonic output voltages while using a 200 kc crystal as the controlling standard. The output of the 200 kc Crystal Controlled Oscillator and the 150 kc output of a Frequency Tripler Stage are both fed to a Mixer Stage. The difference frequency (50 kc) is present in the output of the Mixer Stage. A portion of this 50 kc signal is fed back to the Frequency Tripler Stage to provide the 150 kc output of that stage. It is the 50 kc signal that is obtained from the Mixer Stage that is used to "beat against" (or mix with) the carrier frequency oscillator of the transmitter and is introduced into the Signal Detector Stage in the CFI Unit to produce an audible beat note.

k. OUTPUT.—Output from the Signal Detector in the CFI Unit is coupled to the First Audio Amplifier. The audible beat note is further amplified in passing through the Audio Driver Stage and the Sidetone Amplifier to the headset.

(2) CRYSTAL-CONTROLLED OPERATION— MODEL AN/ART-13B

(a) HIGH FREQUENCY OSCILLATOR AND MULTIPLIER STAGES.—The high frequency oscillator of the CDA-T unit covers a frequency range of 1670 kc to 3600 kc, and its output is fed to the First Frequency Multiplier stage. The First Frequency Multiplier stage functions as a straight through amplifier or as a doubler, depending on the desired transmitter output frequency. For transmission frequencies in the range of 1.67 to 6.0 megacycles, the output of this First Frequency Multiplier

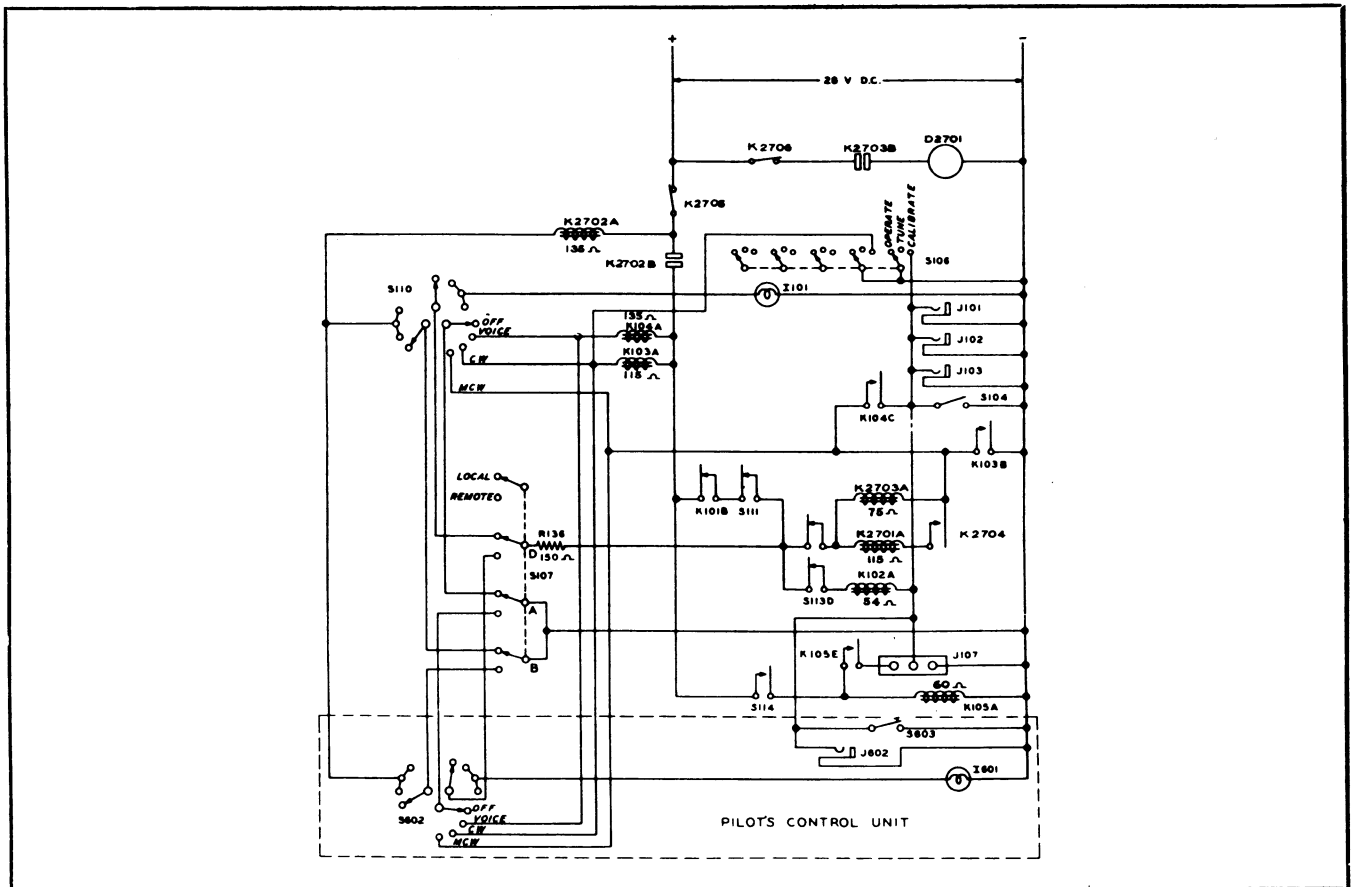

Figure 4-2. Power Control Circuits

stage couples directly to the Power Amplifier. If frequencies between 6.0 and 18.0 megacycles are desired, the output of the First Frequency Multiplier stage is fed to the Second Frequency Multiplier stage which functions as a frequency tripler, whose output couples

to the final amplifier.

(b) LOW FREQUENCY OSCILLATOR.—When transmission frequencies in the 300 kc to 500 kc range are required, the low frequency oscillator of the CDA-T unit is utilized. Output of this oscillator is fed directly

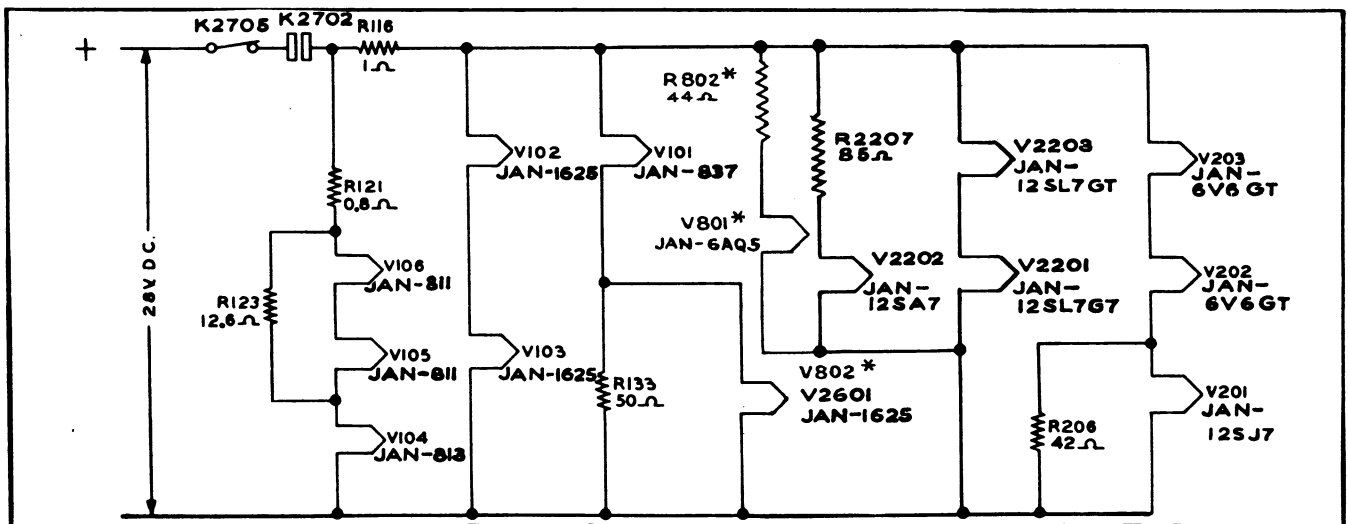

Figure 4-3. Filament Circuits AN/ART-13A and AN/ART-13B

*Applies only to AN/ART-13B

to the Power Amplifier stage. The high frequency oscillators and the multiplier stages are not used.

(3) **CRYSTAL-CONTROLLED OPERATION—HIGH FREQUENCY.**—The high frequency oscillator of the CDA-T unit, in conjunction with the frequency multiplier stages of the basic transmitter provide twenty crystal-controlled output frequencies in the range 1670 kc to 18,000 kc. Utilizing the autotune selection system and manually operated controls on the CDA-T panel, any one of these 20 preset frequencies may be selected without circuit readjustments.

(a) Utilizing a modified Pierce crystal oscillator circuit, this high frequency oscillator employs a Type JAN-6AQ5 tube (V801) and operates over the range of 1670 kc to 4000 kc. The output frequency of the oscillator will always be the frequency of the crystal in the circuit. The twenty crystals utilized to cover the above range are divided into two groups, "A" and "B", with ten crystals in each group. Group selection is accomplished by manually operating the "A-B" switch, S801, located on the CDA-T panel. This switch actuates the "A-B" relay (K811) which selects one group of crystals, shorting out the other group. Individual selection of crystals within a group functions through the autotune system, using positions 1 through 10 of the "CHANNEL" switch. When the autotune has cycled control "A" to the desired position, switch S109 which is mechanically coupled to the "A" control autotune motor, supplies relay operating voltage to one of the ten crystal relays (K801 through K810) which connects the selected crystal to the grid circuit of oscillator tube, V801. Oscillator operation is controlled by opening the cathode lead of V801 as previously described in this section, paragraph 2.d.(2A). Oscillator frequency range for each of the 12 positions of the "A" control are outlined in table 2-2.

(b) The output of the crystal oscillator is coupled through capacitor C150 and resistor R139 to the input of the First Frequency Multiplier stage. For transmitter output frequencies between 1.67 and 6.0 megacycles, this frequency multiplier stage couples directly to the Power Amplifier stage. For frequencies between 6.0 and 18.0 megacycles, the output of the First Frequency Multiplier stage is fed to the Second Frequency Multiplier. The First Frequency Multiplier operates as a straight through amplifier or as a frequency doubler, depending on the transmitter output frequency range desired. For positions 1 through 3 and 7 through 10 of the "A" control, it is an amplifier with its frequency output the same as the crystal. In positions 4 through 6, 11 and 12 of the "A" control, it is a frequency doubler, with its output frequency twice that of the crystal.

(c) The Second Frequency Multiplier stage always operates as a frequency tripler and is used for positions 7 through 12 of the "A" control. Its output couples to the Power Amplifier.

(d) All Power Amplifier and Output circuits operate exactly as outlined previously in paragraph

2.g.(6) of this section.

(4) **CRYSTAL-CONTROLLED—LOW FREQUENCY.**—The low frequency oscillator of the CDA-T unit employs a Type JAN-1625 beam pentode tube V802 in a modified Pierce oscillator circuit to cover the frequency range of 300 to 500 kc. Three crystal sockets, one of which accommodates a dual type crystal holder, permit four channel low frequency operation. Switching from one frequency to another is accomplished through the 4-position rotary switch (S802) which shunts out all crystals not in use. An iron core plate choke (L803) may be varied to obtain resonance and provide maximum oscillator output. Screen and plate voltage for V802 is obtained from a tap on the dynamotor low voltage bleeder. Oscillator operation is controlled by opening the cathode lead of V802 as indicated in figure 4-5A. This cathode returns to ground through switch S114 (which is mechanically operated by the "A" control); through relay K106 (controlled by the "VFO-XTAL" switch S802), and finally through the keying relay contacts K102E. For low frequency operation, control "A" must be in position 13, which couples the oscillator output through the Second Multiplier range switch S103, to the grid of the Power Amplifier tube, V104. Frequency output of this oscillator is always the frequency of the crystal in the circuit.

2. DETAILED ANALYSIS OF MAJOR CIRCUITS.

Simplified schematic diagrams of the basic circuits are presented to complement the discussion. Where Eicor Dynamotor Unit DY-17A/ART-13A is used, basic theory and function apply, but there are differences in reference symbols and circuitry. Referring to Figure 8-41A schematic diagram, note that S2701, S2702 and S2703 correspond to K2705, K2706 and K2704 respectively; also, the filters are sealed assemblies.

a. **POWER CONTROL CIRCUITS.**—Primary power to the dynamotor is controlled by contactors located in Dynamotor DY-17/ART-13A. All relays and contactors which require energizing operate from the 28 V d-c power source. Relays K2705 and K2706 are thermal-operated overload relays which protect the equipment from damage due to overloads. Relay K2704 is a pressure-operated switch which requires no power; it operates when the atmospheric pressure is reduced to that corresponding to altitudes between 20,000 and 25,000 feet above sea level. Complete control of all power contactors is possible from either the transmitter or the remote position.

(1) Figure 4-2 shows a simplified schematic of the power control circuits.

(2) Relays K2705 and K2706 are normally closed and operate to break the primary circuits when an overload occurs. These relays may be returned to the normal position by pressing the "RESET" buttons located on the Dynamotor Unit. Primary overload relay K2705 is designated as TRANSMITTER RESET

and dynamotor overload relay K2706 as DYNAMOTOR RESET. With the overload relays K2705 and K2706 in normally closed positions and the "LOCAL-REMOTE" switch, S107, in the "LOCAL" position, placing the "EMISSION" selector switch, S110, in the "VOICE" position will complete the circuit necessary for the operation of the primary power contactor, K2702. The primary power contactor coil, K2702A, is energized by the circuit through LOCAL-REMOTE switch S107, EMISSION selector switch S110, primary power contactor coil K2702A and the contacts of primary overload relay K2705. When the power control relay, K2702, has operated, the circuit necessary for the operation of the "voice" relay, K104, is completed through the contacts of primary overload relay K2705, primary power contactor contacts K2702B, "voice" relay coil K104A, the contacts of EMISSION selector switch S110, and the contacts of LOCAL-REMOTE switch S107. If the power level switch, S106, is in either the "TUNE" or "OPERATE" position, it is necessary to operate the TEST switch, S104, or to complete the circuit through the throttle switch jack, J101, MICROPHONE jack J102, or KEY jack J103, before the dynamotor input relay, K2703A, will operate.

(3) Operating the EMISSION selector switch, S110, to the CW position completes the circuit necessary for the operation of CW relay K103, through the contacts of LOCAL-REMOTE switch S107, EMISSION selector switch S110, and CW relay coil K103A. When the CW relay, K103, has operated, the coil of dynamotor input relay K2703 is energized through the contacts of CW relay K103B, dynamotor input relay coil K2703A, the contacts of safety interlock switch S117, the contacts of Autotune limit switch section S111, motor control relay contacts K101B, primary power contactor contacts K2702B, and the normally closed contacts of overload relay K2705.

(4) If the EMISSION selector switch, S110, is operated to the MCW position, the primary power contactor K2702, is operated by the circuit through the normally closed contacts of overload relay K2705, the coil of primary power contactor K2702, the contacts of EMISSION selector switch S110, and the contacts of LOCAL-REMOTE switch S107. Dynamotor input relay K2703 is energized by the circuit through the normally closed contacts of primary overload relay K2705, motor control relay contacts K101B, the contacts of Autotune limit switch section S111, the contacts of safety interlock switch S117, dynamotor input relay coil K2703A, the contacts of EMISSION selector switch S110, and the contacts of LOCAL-REMOTE switch S107. The operation of dynamotor input relay K2703 closes the contacts of this relay and applies power to the motor section of dynamotor D2701 through the normally closed contacts of dynamotor overload relay K2706.

(5) If the power level switch S106 is operated to the "CALIBRATE" position, CW relay K103 is oper-

ated through the normally closed contacts of primary overload relay K2705, primary power contactor contacts K2702B, CW relay coil K103A and the contacts of power level switch S106. The dynamotor input relay, K2703, is operated by the circuit through the normally closed contacts of primary overload relay K2705, primary power contactor contacts K2702B, Autotune motor control relay contacts K101B, the contacts of Autotune limit switch section S111, the contacts of safety interlock switch S117, dynamotor input relay coil K2703A, and CW relay contacts K103B.

(6) With LOCAL-REMOTE switch S107 in the local position the primary power contactor, K2702, and the transmitter panel pilot lamp, I101, will be energized when the EMISSION selector switch, S110, is in any position other than the "OFF" position. Primary power contactor K2702 will be operated by the circuit through the normally closed contacts of primary overload relay K2705, primary power contactor coil K2702A, the contacts of EMISSION selector switch S110, and the contacts of LOCAL-REMOTE switch S107. The pilot lamp, I101, will be energized through the normally closed contacts of primary overload relay K2705, primary power contactor contacts K2702B, Autotune motor control relay contacts K101B, the contacts of Autotune limit switch section S111, the contacts of safety interlock switch S117, the pilot lamp series resistor, R136, the contacts of LOCAL-REMOTE switch S107 and the contacts of EMISSION selector switch S110.

(7) When the LOCAL-REMOTE switch, S107, is placed in the "REMOTE" position, control of all power circuits is transferred from the transmitter panel controls to the controls located on the remote control unit.

Note

Operation of the control panel is identical to that of the control box described below except that there is no key or microphone jack on the panel.

(8) If the EMISSION selector switch, S602, is placed in the "VOICE" position, the primary power contactor, K2702, is energized by the circuit through the normally closed contacts of primary overload relay K2705, primary power contactor coil K2702A, the contacts of EMISSION selector switch S602, and the contacts of LOCAL-REMOTE switch S107. To complete the circuit necessary for the operation of the dynamotor input relay, K2703, the telegraph key, S603, must be operated or the microphone jack, J602, circuit must be completed. The "voice" relay, K104, is operated by the circuit through the normally closed contacts of primary overload relay K2705, primary power contactor contacts K2702B, "voice" relay coil K104A, the contacts of EMISSION selector switch S602, and the contacts of LOCAL-REMOTE switch S107. The dynamotor input relay, K2703, is operated by the circuit through the normally closed contacts of pri-

mary overload relay K2705, primary power contactor contacts K2702B, Autotune motor control relay contacts K101B, the contacts of Autotune limit switch section S111, the contacts of safety interlock switch S117, dynamotor input relay coil K2703, "voice" relay contacts K104C and telegraph key S602 or microphone jack J602.

(9) When the EMISSION selector switch, S602, is operated to the CW position, the CW relay, K103, is operated by the circuit through the normally closed contacts of primary overload relay K2705, primary power contactor contacts K2702B, CW relay coil K103A, the contacts of EMISSION selector switch S602 and the contacts of LOCAL-REMOTE switch S107. The operation of CW relay K103 completes the circuit necessary for the operation of dynamotor input relay K2703. Dynamotor input relay K2703 is operated by the circuit through the normally closed contacts of primary overload relay K2705, primary power contactor contacts K2702B, Autotune motor control relay contacts K101B, the contacts of Autotune limit switch section S111, the contacts of safety interlock switch S117, dynamotor input relay coil K2703A and CW relay contacts K103B. The operation of the dynamotor input relay, K2703, applies power to the motor section of dynamotor D2701 through the normally closed contacts of dynamotor overload relay K2705 and dynamotor input relay contacts K2703B.

(10) If the EMISSION selector switch, S602, is operated to the MCW position, primary power contactor K2702 is held operated and dynamotor input relay K2703 is energized through the normally closed contacts of primary overload relay K2705, primary power contactor contacts K2702B, Autotune motor control relay contacts K101B, the contacts of Autotune limit switch section S111, the contacts of safety interlock switch S117, dynamotor input relay coil K2703A, the contacts of EMISSION selector switch S602 and the contacts of LOCAL-REMOTE switch S107.

(11) LOCAL-REMOTE CIRCUITS

(a) AN/ART-13A

With LOCAL-REMOTE switch S107 in the "REMOTE" position the primary power contactor, K2702, and the pilot lamp, I601, are energized when EMISSION selector switch S602 is in any position other than the "OFF" position. Primary power contactor K2702 is energized through the normally closed contacts of primary overload relay K2705, primary power contactor coil K2702A, the contacts of EMISSION selector switch S602, and the contacts of LOCAL-REMOTE switch S107. The pilot lamp, I601, is energized by the circuit through the normally closed contacts of primary overload relay K2705, primary power contactor contacts K2702B, Autotune motor control relay contacts K101B, the contacts of Autotune limit switch section S111, the contacts of safety interlock switch S117, pilot lamp series resistor R136, the contacts of LOCAL-REMOTE switch S107 and the contacts of EMISSION selector switch S602.

(b) AN/ART-13B

Supplementing the LOCAL-REMOTE circuits as outlined in the preceding paragraph, the AN/ART-13B utilizes an additional single pole, double throw wafer on "LOCAL-REMOTE" switch S107. For crystal-controlled operation, this wafer connects to an "A-B" toggle switch on the remote control unit and to the "A-B" relay (K811) and "A-B" switch (S801) of the CDA-T unit. With the "LOCAL-REMOTE" switch in the "LOCAL" position, S801 controls operation of the "A-B" relay, changing the group of crystals as desired. With the "LOCAL-REMOTE" switch in the "REMOTE" position, the "A-B" toggle switch of the remote unit controls the crystal group switching.

(12) The power change relay, K2701, operates when the pressure is reduced to a pressure corresponding to altitudes between 20,000 and 25,000 feet above sea level by the operation of the pressure operated relay, K2704. If the transmitter is operating with VOICE emission, power change relay coil K2701A is energized by the circuit through the normally closed contacts of primary overload relay K2705, primary power contactor contacts K2702B, Autotune motor control relay contacts K101B, the contacts of Autotune limit switch section S111, the contacts of safety interlock switch S117, power change relay coil K2701A, the contacts of pressure operated relay K2704, the contacts of "voice" relay K104 and the closed circuit of MICROPHONE jack J102. If the transmitter is operating with CW emission and pressure operated relay K2704 has operated, the operating circuit for power change relay K2701 is through the normally closed contacts of primary overload relay K2705, primary power contactor contacts K2702B, Autotune motor control relay contacts K101B, the contacts of Autotune limit switch section S111, the contacts of safety interlock switch S117, power change relay coil K2701A, the contacts of pressure operated relay K2704 and CW relay contacts K103B. If the transmitter is operating with MCW emission, the energizing circuit for power change relay K2701 is through the normally closed contacts of primary overload relay K2705, primary power contactor contacts K2702B, Autotune motor control relay contacts K101B, the contacts of Autotune limit switch section S111, the contacts of safety interlock switch S117, power change relay coil K2701A, the contacts of pressure operated relay K2704, the contacts of EMISSION selector switch S110 or S602 and the contacts of LOCAL-REMOTE switch S107.

b. FILAMENT CIRCUITS.—The filament power circuits of the transmitter are a combination of series and parallel connections. The filaments are supplied with power from the 28 volt d-c source. Figure 4-3, covering Model AN/ART-13A and Figure 4-3A covering Model AN/ART-13B, show the filament circuits in simplified form. All filament power is controlled by primary power contactor contacts K2702. The primary overload relay, K2705, operates to break the fila-

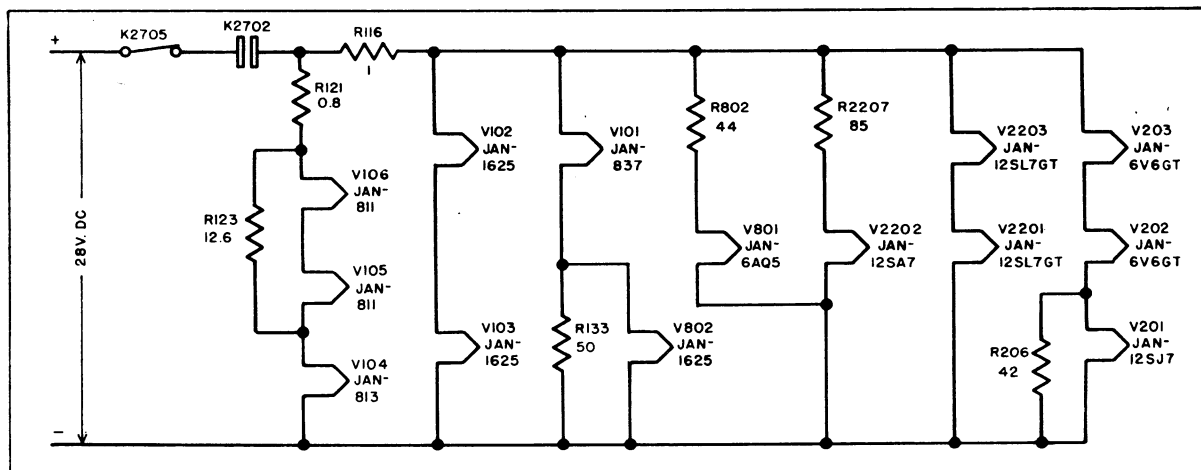

Figure 4-3A. Filament Circuits — AN/ART-13B

ment circuit when an overload occurs in the filament or associated circuits.

c. HIGH VOLTAGE CIRCUITS.—Figure 4-4 shows, in simplified form, the high voltage circuits employed in the equipment.

(1) The dynamotor employs an armature with dual windings and two commutators to give output voltages of 400 volts d-c and 750 volts d-c. (The Eicor unit has slightly higher output voltages of 410 and 780.) To obtain the high voltage necessary for application to the power amplifier and modulator tubes, the 400 volt output is connected in series with the 750 volt output of the dynamotor. On the diagrams, figure 4-4 and figure 8-42, the low voltage section of the dynamotor is designated as G1 and the high voltage section is

designated as G2. When the power change relay, K2701, is in the normal position the positive lead from low voltage dynamotor section G1 is connected to the negative lead of high voltage dynamotor section G2 through the contacts of power change relay K2701, and milliammeter multiple resistor R2701B. The circuit necessary to energize the coil of power change relay K2701 is completed by the operation of the pressure-operated relay, K2704. When power change relay K2701 operates, the negative lead of high voltage dynamotor section G2 is disconnected from the positive lead of low voltage dynamotor section G1 and is grounded through milliammeter multiplier resistor R2701A and B and the contacts of power change relay K2701. Spark suppressing circuits have been in-

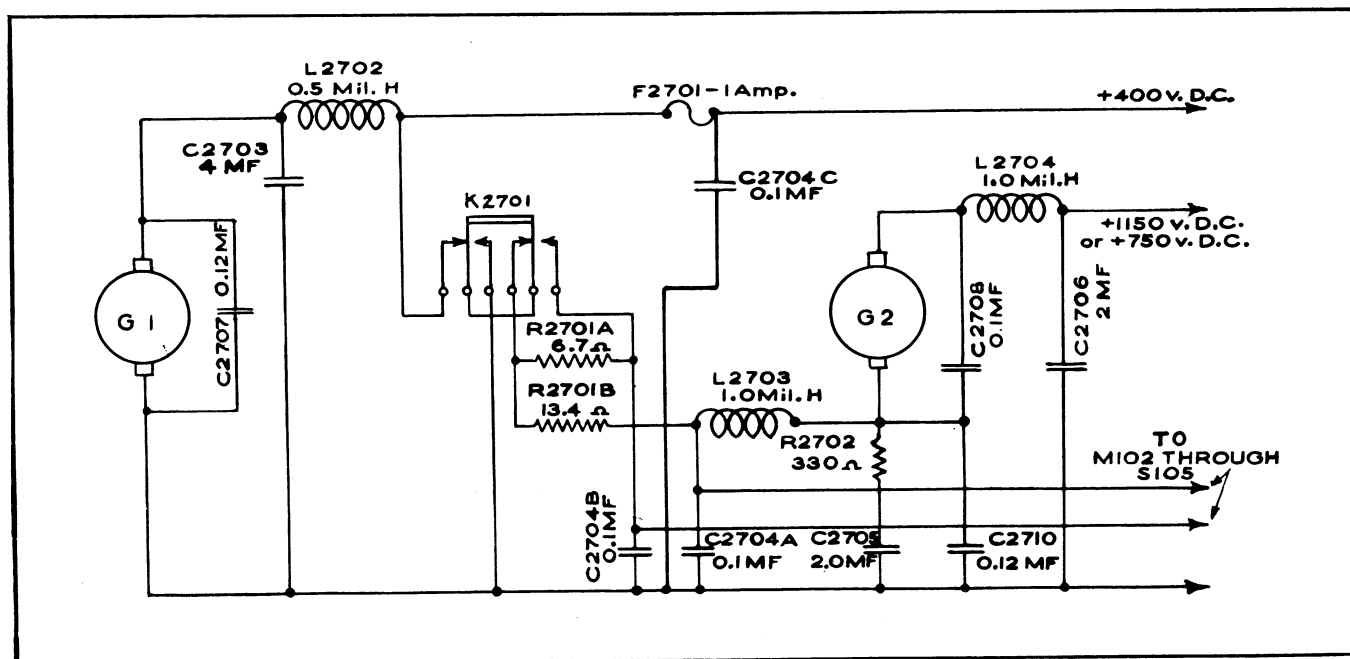

Figure 4-4. High Voltage Circuits

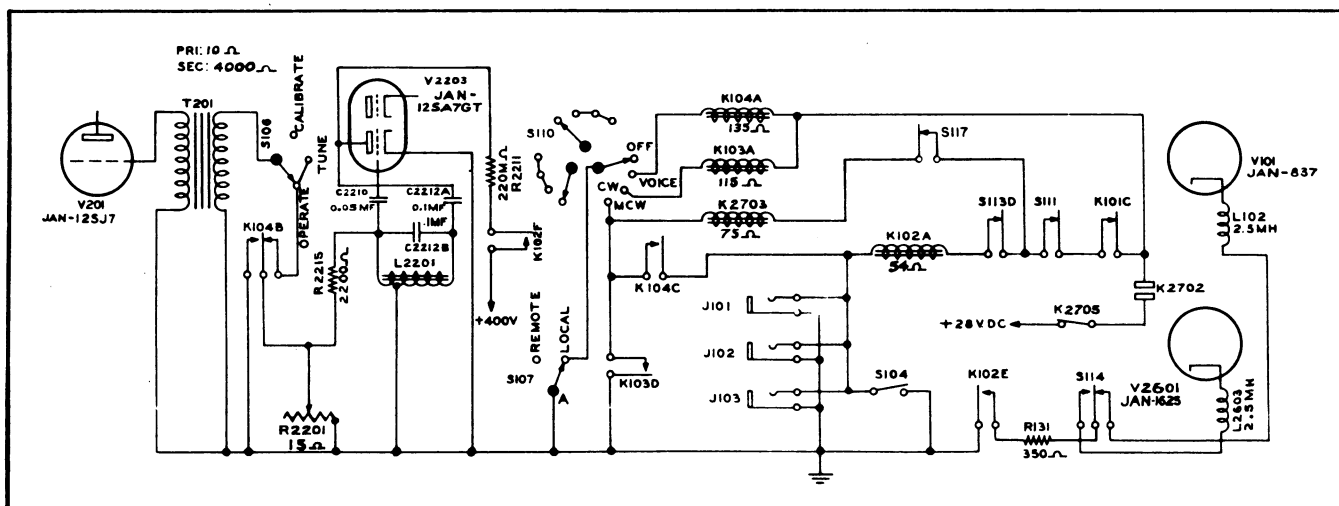

Figure 4-5. Emission Selection and Carrier Control Circuits AN/ART-13A

incorporated in the output circuits of the dynamotor to suppress the sparks generated at the motor and generator brushes.

d. EMISSION SELECTION AND CARRIER CONTROL.

(1) The "EMISSION" selector switch S110 is a combination transmitter "ON-OFF" switch and "EMISSION" selector switch. Operating "EMISSION" selector switch S110 to the "VOICE," "CW" or "MCW" position will operate the primary contactor K2702 (see fig. 4-5). (Note: Refer to paragraph 3a, this section for detailed explanation of the operation of primary power contactor K2702.) Selecting "VOICE" emission by the operation of "EMISSION" selector switch S110 operates "VOICE" relay K104. "VOICE" relay contacts K104B disconnect the output of the "MCW" oscillator tube, V2203, from the input to the speech amplifier. "VOICE" relay contacts K104C connect the coil of dynamotor input relay K2703 to the emission control circuits of throttle switch jack J101, "MICROPHONE" jack J102, "KEY" jack J103 and the "TEST" switch, S104. Selecting "CW" emission completes the circuit necessary for the operation of "CW" relay K103. "CW" relay contacts K103D complete the circuit necessary for the operation of dynamotor input relay K2703 which, in turn, applies primary power to the dynamotor, D2701. Selecting "MCW" emission operates dynamotor input relay K2703 directly.

(2) MODEL AN/ART-13A (Fig. 4-5)

The r-f carrier is keyed by opening the cathode circuit of the oscillator and removing the screen voltage from the power amplifier. The keying relay, K102, has six sets of contacts. The contacts K102E complete the oscillator cathode circuit by grounding resistor R131. Keying relay contacts K102E and resistor R131 serve as a cathode return for both the h-f oscillator tube, V101, and the l-f oscillator tube, V2601. The desired oscillator circuit is selected by the operation of oscillator selecting switch S114 which operates in conjunction with Control A.

(3A) MODEL AN/ART-13B (Fig. 4-5A).—The r-f carrier is keyed by opening the cathode circuit of the oscillator and removing the screen voltage from the power amplifier. Selection of the channel and method of operation (VFO or XTAL) is accomplished by switching the cathode ground return lead to the desired oscillator. Switch S114, mechanically controlled by the "A" control dial, selects the frequency band. Positions 1 through 12 of control "A" permit operation in the high frequency band; position 13 the low frequency band. Choice of operation, XTAL or VFO, is controlled by switch S802 and relay K106. With switch S802 turned to "XTAL", relay K106 is energized. This relay shorts out R131, and depending on the setting of the "A" control, grounds the crystal oscillator cathode (V801 or V802) through S114 and keying relay con-

tion, voltage is removed from the screen grid of power amplifier tube V104 and this grid is connected back to the control grid of the same tube through a pair of contacts on switch S106. This connection permits negative voltage on control grid to be applied to screen grid and thereby cuts off output from power amplifier stage. The keying relay, K102, may be operated by closing the circuits of the Throttle Switch jack, J101, the "MICROPHONE" jack, J102, or the "KEY" jack, J103, or by operating the "TEST" switch, S104. Keying interlock switch S113D is operated in conjunction with output network switch S113, and breaks the energizing circuit to the coil of keying relay K102 when output network switch S113 is operated, thus removing excitation from the R-F circuits to prevent arcing at the switch contacts. The Autotune limit switch section, S111, and Autotune motor control relay contacts K101C are also connected in series with keying relay coil K102A so that when Autotune limit switch section S111 or Autotune motor control relay K101 operates, the holding circuit for keying relay K102 will be broken and arcing at all switch contacts will be prevented.

e. AUDIO CIRCUITS.—The audio system consists of a two stage speech amplifier, push-pull modulators, a sidetone amplifier, and an "MCW" audio tone oscillator, See simplified circuit in figure 4-6.

(1) SPEECH AMPLIFIER.—Either of two types of microphones may be used with this equipment. The input to the speech amplifier has been designed so that by operating a switch, proper connections are made to the "MICROPHONE" jack J102, to match the output of either a carbon or dynamic type of microphone. The

microphone circuit selector switch, S201, is located beneath the tuning chart on the front panel of the transmitter (see fig. 2-2). If microphone circuit selector switch S201 is placed in the "CARBON" position, the bleeder composed of R201, R202, R203, and R204 connected between the positive terminal of the 28-v d-c power source and ground (Br. earth) provides the voltage necessary for the operation of the carbon type of microphone. The operation of microphone circuit selector switch S201 also connects limiting resistor R203 between "MICROPHONE" jack J102 and the input circuit of the speech amplifier to reduce the level of the output of the carbon microphone to the level of the output of a dynamic microphone. Thus, no audio gain control has been provided because the level of the input to the speech amplifier is the same when using a dynamic microphone as it is when using a carbon microphone. If microphone circuit selector switch S201 is placed in the "DYNAMIC" position, the voltage is removed from the input circuit and the "MICROPHONE" Jack, J102, is connected in series with limiting resistor R216 and the primary of the input transformer T201. The two stage speech amplifier employs a Type JAN-12SJ7 1st Audio Amplifier tube, V201, and a Type JAN-6V6GT audio driver tube, V202. The output of the microphone is coupled by the input transformer, T201, to the grid of 1st Audio Amplifier tube V201. The output of 1st Audio Amplifier tube V201 is coupled to the grid of audio driver tube V202 by the capacitor C204. The output of audio driver tube V202 is coupled to the grids of the modulator tubes, V105 and V106, by driver transformer T202.

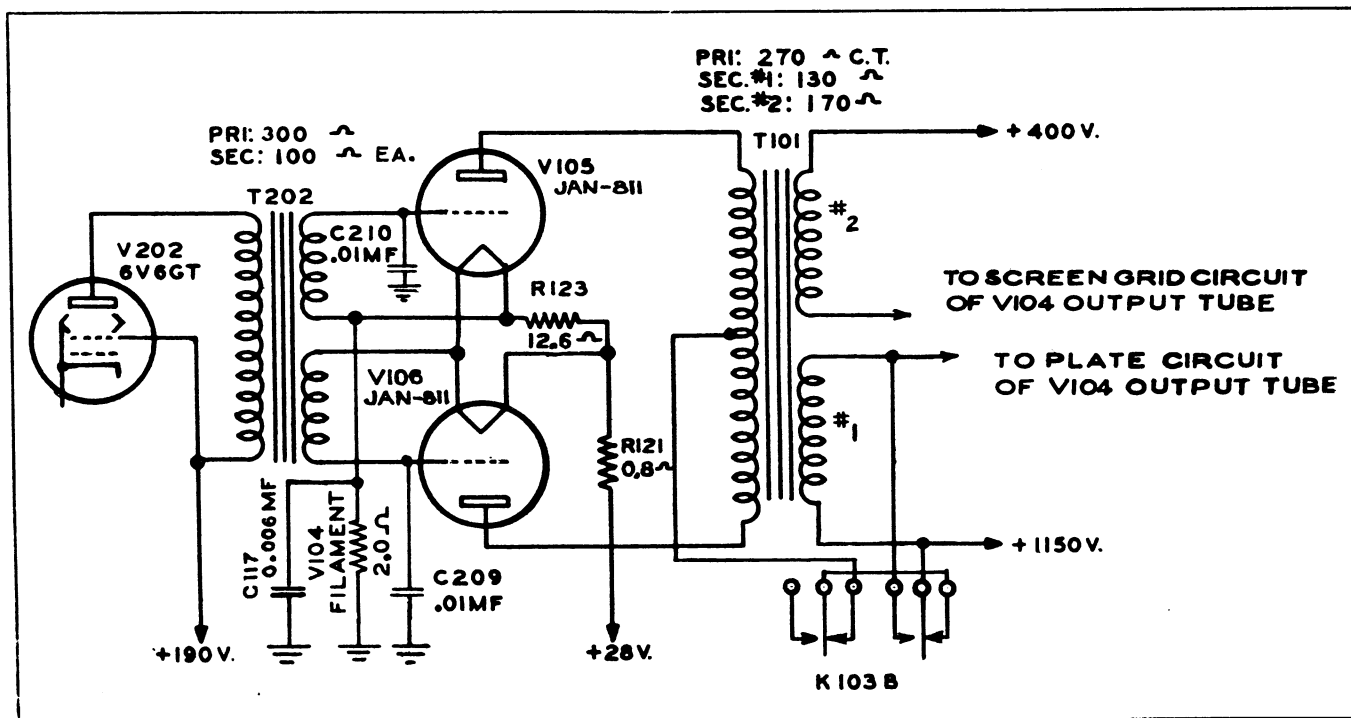

Figure 4-7. Modulator Circuit

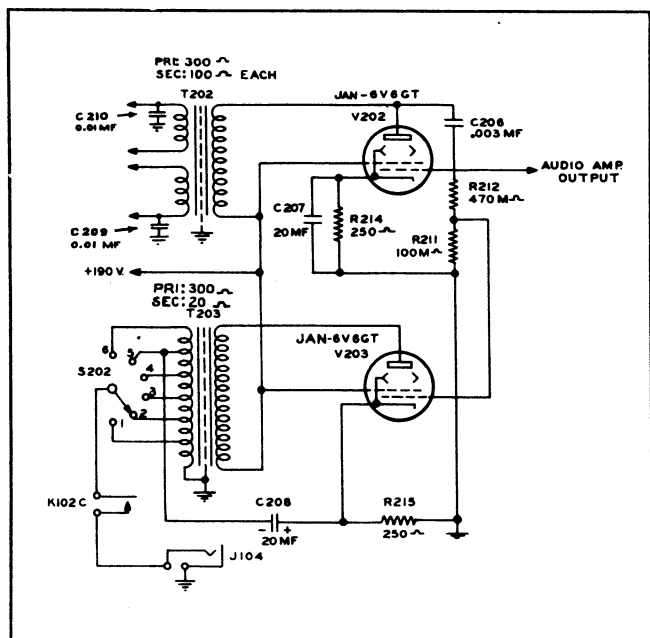

Figure 4-8. Sidetone Amplifier Circuit

(2) MODULATOR.—The modulator employs two Type JAN-811 high mu triodes connected in push-pull, and operating Class B. The modulators are capable of modulating the carrier (100 watts nominal) at least 90% with full voltage applied to the power amplifier. While the JAN-811 is essentially a zero bias tube when used with plate voltages as high as 1150 volts d-c, it becomes necessary to apply some bias to the grid of the tube to keep the static plate current as low as practicable. In this application the bias is obtained from the 28-volt d-c supply by utilizing the average voltage drop through the filaments of the tubes to obtain equal voltage for application to the grids of both modulator tubes. The output of the modulators is coupled to the r-f circuit by modulation transformer T101 (see fig. 4-7). Both the screen and plate of the final amplifier tube, V104, are modulated. The full output voltage of the dynamotor 1150 volts d-c, is applied to the plates of the modulator tubes, V105 and V106. "CW" relay contacts K103B remove plate voltage from the modulators when "CW" emission is selected.

(3) SIDETONE AMPLIFIER.—A sidetone amplifier is incorporated in the same unit as the two stage speech amplifier.

The amplifier employs a Type JAN-6V6GT beam pentode tube, V203. The output of the audio driver tube, V202, in addition to being applied to the primary of driver transformer T202, is applied to a voltage dividing system consisting of C206, R211 and R212. (See fig. 4-8). The grid of the sidetone amplifier tube, V203, is coupled to the junction of R211 and R212 and the voltage developed across resistor R211 drives the grid of V203 to provide sufficient output from the sidetone amplifier to operate headphones or speaker. The output of sidetone amplifier tube V203

is coupled to the "SIDETONE" jack, J104, by "SIDE-TONE" impedance matching transformer T203 through sidetone "OUTPUT" switch S202 and keying relay contacts K102C. The turns-ratio of "SIDE-TONE" impedance matching transformer T203 may be varied by operating the sidetone "OUTPUT" switch S202. The output of the sidetone amplifier is keyed by the operation of keying relay K102. The "SIDETONE" jack, J104, may be connected in parallel with auxiliary jack J105 by connecting a jumper between terminals 26 and 27 of cable connector J106. The necessary plate and screen voltages for the sidetone amplifier are obtained by tapping the bleeder system of the low voltage output of the dynamotor.

(4) "MCW" OSCILLATOR.—The "MCW" audio tone oscillator utilizes a Type JAN-12SL7GT dual triode tube, V2203. One triode section of this tube is used for the "MCW" audio oscillator and the other triode section is used in conjunction with the CFI Unit which is described in the next paragraph. The "MCW" oscillator is in operation whenever keying relay contacts K102F apply voltage to the plate of "MCW" oscillator tube, V2203, when keying relay K102 is operated (see fig. 4-9). The audio frequency output of the "MCW" oscillator is controlled by varying "MCW" output control resistor R2201. A screwdriver slot for varying resistor R2201 is accessible through a hole at the rear of the "MCW-CFI" Unit. The voltage developed across MCW output control resistor R2201 is coupled to the input of the speech amplifier through "VOICE" relay contacts K104B and the contacts of power level switch, S106. When "VOICE" emission has been selected, "VOICE" relay contacts K104B disconnect the output of the "MCW" oscillator tube, V2203, from the input circuit of the speech amplifier. During periods of "CW" transmission the "MCW" oscillator is keyed and the output is fed to the input of the speech amplifier. The output of the sidetone amplifier provides a means of monitoring the keying.

f. "CFI" CALIBRATION OSCILLATOR UNIT.—A regenerative frequency divider circuit is employed

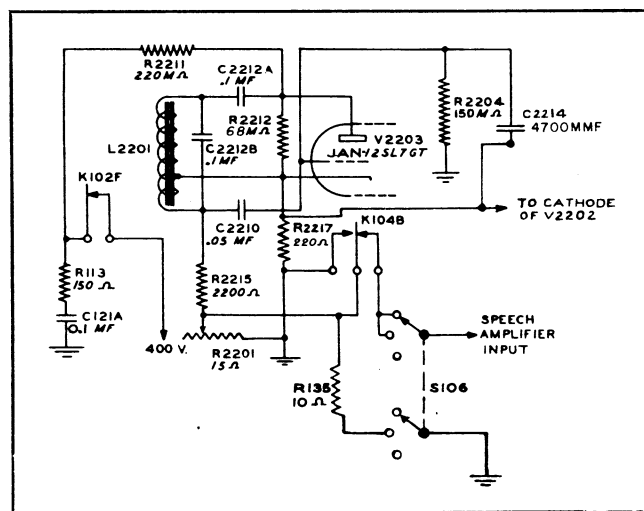

Figure 4-9. MCW Oscillator Circuit

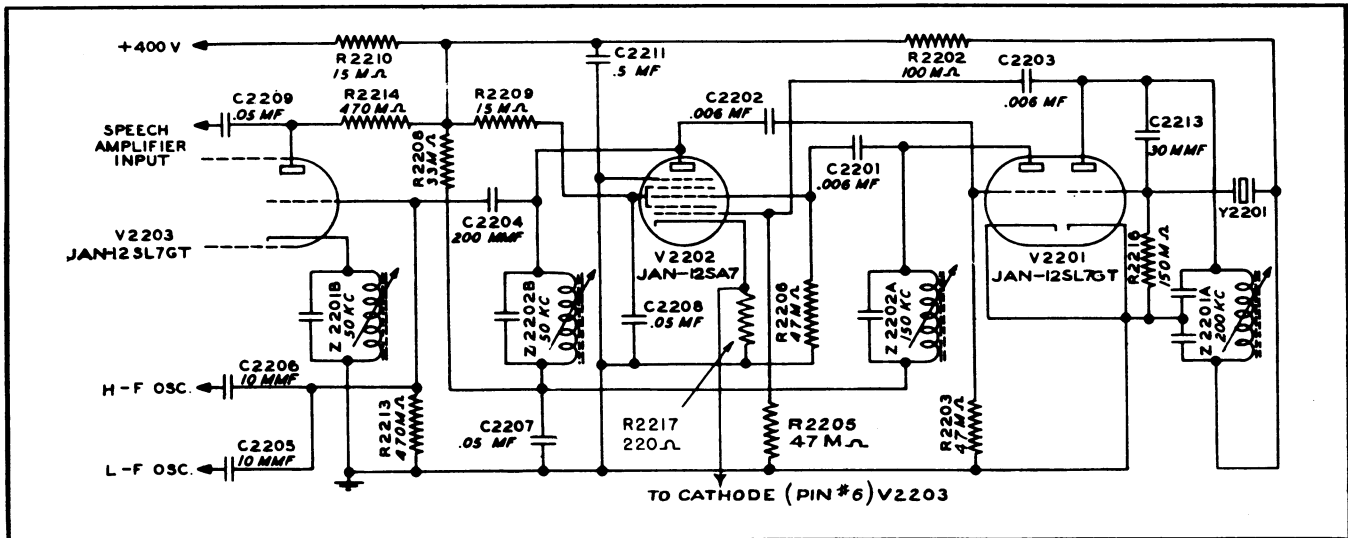

Figure 4-10. CFI Oscillator Circuits

in the "CFI" Unit to obtain a stable 50-kc fundamental frequency and harmonics that are used to check the frequency of the carrier oscillator of the transmitter. The circuit utilizes a 200-kc crystal as the controlling standard. A simplified schematic diagram of this oscillator is shown in figure 4-10. Both triode sections of a JAN-12SL7GT tube, V2201, a JAN-12SA7 pentagrid converter tube, V2202, and one section of another JAN-12SL7GT tube, V2203, are used in the calibration oscillator. Plate voltage is supplied to these tubes from the low voltage output section of the dynamotor and is applied when the power level switch S106 is operated to the "CALIBRATE" position. Operating power level switch S106 to "TUNE" or "OPERATE" positions removes the plate voltage from the "CFI" tubes and disables the circuit.

(1) The application of plate voltage to the oscillator section of JAN-12SL7GT tube V2201, starts the 200-kc crystal oscillator. This produces a frequency of

200 kc, plus random tube and circuit noises, to appear on the injector grid of JAN-12SA7 mixer tube V2202. The random noises appearing on the plate of JAN-12SA7 excites frequency tripler section of JAN-12SL7GT tube V2201. Since the plate circuit of this section of JAN-12SL7GT tube V2201 is tuned to 150 kc, only the 150-kc components of the random noises are amplified. This 150-kc component of random noise is then impressed on control grid of JAN-12S7 mixer tube. Since the plate circuit of the JAN-12SA7 is tuned to 50 kc, the 50-kc difference frequency produced by the combination of a 200-kc voltage and a 150-kc voltage appearing in the JAN-12SA7 tube, is the frequency amplified. This 50-kc voltage continues to excite the second triode section of V2201, which because of its tuned 150-kc plate circuit, triples the frequency and sustains the 150-kc voltage on the JAN 12SA7 grid. The 50-kc voltage appearing on the JAN-12SA7 plate becomes the calibration frequency.

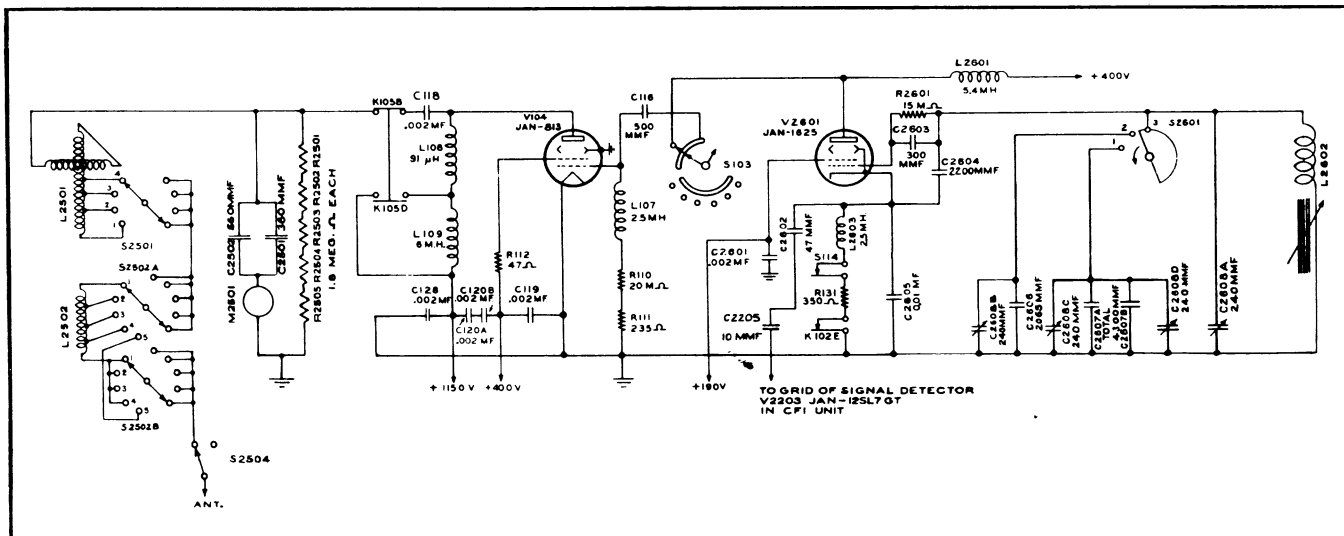

Figure 4-11. VFO Low Frequency R-F Circuits AN/ART-13A

(2) One triode section of the second JAN-12SL7GT tube, V2203, is employed as a signal detector. A portion of the 50-kc voltage appearing on the plate of JAN-12SA7 tube, V2202, is coupled to the grid of V2203 by capacitor C2204. Depending upon the transmission frequency selected, a portion of the output of the low frequency oscillator or the high frequency oscillator is coupled to the grid of V2203 by capacitor C2206 or C2205. The beat note that is generated in the signal detector is coupled to the input of the first amplifier by capacitor C2209.

(3) When power level switch S106 is operated to the "CALIBRATE" position, the circuit from capacitor C2209 to the input of the first audio amplifier is completed and the output of the signal detector will be heard through the sidetone circuits of the transmitter.

(4) The second triode section of V2203 is utilized as the "MCW" audio oscillator. A description of this circuit is given in paragraph 2e(4) entitled "MCW OSCILLATOR."

(5) The inductor tuning screws that protrude through the sides of the shield cans containing tank circuits Z2201A, Z2201B, Z2202A and Z2202B should not be disturbed for any reason unless the alignment procedure is thoroughly understood. The alignment of these circuits is described in the Maintenance section of this manual.

g. RADIO FREQUENCY CIRCUITS

RADIO TRANSMITTING SET AN/ART-13A.

Radio Transmitter T-47A/ART-13 employs two r-f systems. One system covers the frequency range 200 kc to 600 kc and the other system the frequency range 2000 kc to 18,100 kc. Separate oscillator tubes are employed for each frequency range. The same power amplifier tube serves both systems.

(1) LOW-FREQUENCY R-F CIRCUITS.—The l-f oscillator employs a Type JAN-1625 beam pentode tube, V2601. This oscillator operates in the frequency range 200 kc to 600 kc. Frequency range is covered in three bands which have the following individual ranges:

200 kc to 285 kc
285 kc to 415 kc
415 kc to 600 kc

A combination of capacitive and inductive grid tuning is employed. The l-f oscillator "COARSE" tuning switch, S2601 (control "F"), varies the grid circuit capacity by increasing the number of padding capacitors connected in the circuit as the switch is rotated toward the lowest frequency position (see fig. 4-11). Trimmer capacitors have been connected in parallel with the padding capacitors to provide means of fine adjustment of grid circuit capacity. These trimming capacitors are of the ceramic type and the capacity of each may be varied by rotating one plate with

respect to the other. In spite of the small physical size, this type of capacitor provides a means of varying the capacity over a wide range. With the end points of the frequency band set and the trimmer capacitors adjusted to give some overlap in each position of l-f oscillator "COARSE" tuning switch S2601, all fine frequency adjustments within the frequency range of each switch position are made by varying the inductance of the inductor L2602. The inductance of L2602 is altered by adjusting the position of the core, which is actuated by a tuning screw. The position of the tuning core within the inductor is determined by control G. When l-f operation is desired and the l-f (13) position of control A has been selected, the cathode circuit of the l-f oscillator tube, V2601 is coupled through the contacts of oscillator selecting switch S114 and bias resistor R131 to keying relay contacts K102E of keying relay K102. Operation of keying relay K102 completes the cathode circuit to ground. Screen voltage for l-f oscillator tube V2601 is obtained by tapping the dynamotor low voltage output bleeder. The output of l-f oscillator tube V2601 is coupled to the grid of the final amplifier tube, V104, by second multiplier range switch S103 when control A is operated in the l-f position. Selecting l-f operation operates output circuit selecting relay K105 which connects the plate circuit of final amplifier tube V104 to the external loading circuits in Antenna Loading Unit CU-32/ART-13A. The h-f output network is completely removed from the circuit by the operation of output circuit selecting relay K105. Output circuit selecting relay contacts K105D remove the shorting connection across the plate choke, L109. Screen voltage for final amplifier tube V104 is obtained from the low voltage output of the dynamotor. The full voltage of the high voltage section of the dynamotor is applied to the plate of final amplifier tube V104. The external loading coil in addition to being an antenna loading coil is also the power amplifier plate tank circuit. A tapped inductor and variometer provides means of adjusting the power amplifier plate tank tuning.

(2) HIGH FREQUENCY R-F CIRCUITS.—The h-f oscillator employs a pentode Type JAN-837 tube, V101, in a variable frequency oscillator circuit. The oscillator operates within the frequency range 1000 kc to 1510 kc. This frequency range is covered in two bands, 1000 kc to 1200 kc, and 1200 kc to 1510 kc. The band of frequencies within which output is obtained, is dependent on the position of h-f oscillator range switch S101. Capacitors C101 and C135, (see fig. 4-12) are connected in the grid circuit of the h-f oscillator tube V101, by h-f oscillator range switch S101 which is operated by control A. Alternate positions of control A add or remove the padding capacitors C101 and C135. With control A in the 2.0-mc to 2.4-mc position h-f oscillator range switch S101 is closed, giving the maximum grid circuit capacitance

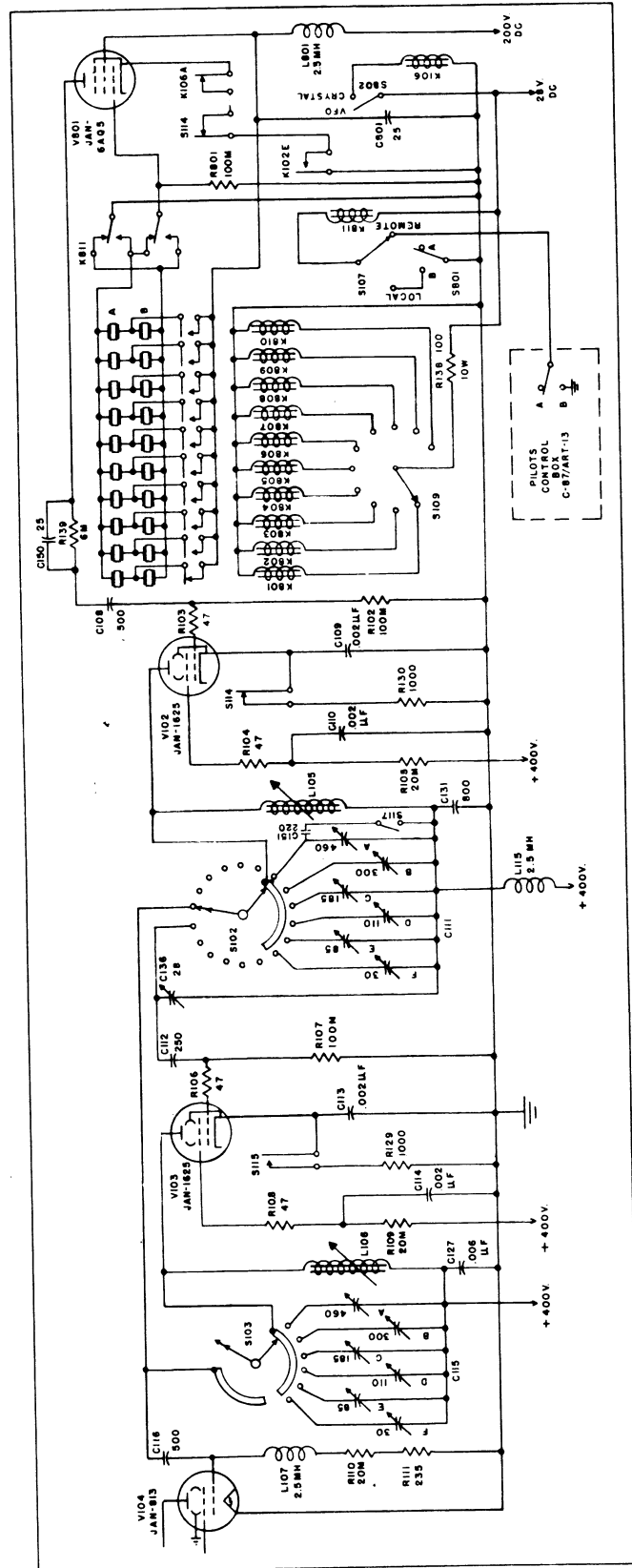

Figure 4-12A. High Frequency R-F Circuits — Crystal Controlled Operation — AN/ART-13B

and consequently the lowest frequency output. Therefore, when control A is in the 2.0-mc to 2.4-mc position, oscillator output is obtained in the frequency range 1000 kc to 1200 kc. When control A is rotated to the 2.4-mc to 3.0-mc position, h-f oscillator range switch S101 is opened, removing capacitors C101 and C135 from the circuit, and oscillator output is obtained in the frequency range 1200 kc to 1510 kc. When control A is operated to the 3.0-mc to 3.6-mc position, h-f oscillator range switch S101 is again operated to the closed position and oscillator output is obtained in the frequency range 1000 kc to 1200 kc. In the remaining nine h-f positions of control A, h-f oscillator range switch S101 is alternately opened and closed to give oscillator output as indicated above. Trimming capacitors C134 and C135 have been provided to aid in setting the end-points of the two frequency bands. When setting the h-f end of the 1000-kc to 1200-kc band, the grid capacity is trimmed using variable capacitor C135. When the h-f end of the 1200-kc to 1510-kc band is set, the grid tuning capacity is trimmed by using variable capacitor C134. Fine frequency adjustment within each band is made by varying the inductance of grid tuning inductor L101. The inductance of L101 is varied by adjusting the position of the tuning slug within the coil. The position of the tuning slug is determined by control B. Approximately 20 revolutions of control B will cover the entire frequency range of the band upon which the oscillator is operating, with some overlap on both ends of the band. A portion of the output of the h-f oscillator tube, V101, is fed to the grid of the CFI signal detector tube, V2203, to permit the calibration of h-f oscillator against the crystal oscillator circuit of CFI Unit. When h-f operation has been selected, rotating control A to any one of the twelve h-f positions will close the cathode circuit of h-f oscillator tube, V101, through cathode choke L102, the contacts of oscillator selecting switch S114 and the cathode resistor R131, to keying relay contacts K102E. The operation of keying relay K102 complete the cathode circuit to ground. Screen voltage for h-f oscillator tube V101 is obtained by tapping the bleeder across the low voltage output of the dynamotor. The full voltage of the low voltage section of the dynamotor is applied to the plate of h-f oscillator tube V101.

(3) To obtain r-f output in the frequency range 2000 kc to 18,100 kc, the output of the h-f oscillator must be multiplied from two to twelve times. The frequency multiplier tubes, V102 and V103, are inoperative when l-f operation has been selected. The frequency multiplier stages employ Type JAN-1625 beam pentode tubes. The first multiplier tube may operate as a frequency doubler, tripler, or quadrupler. The second multiplier tube operates only as a frequency tripler. The number of times that the frequency of the output of the h-f oscillator tube, V101, is multiplied is dependent upon the position of first multiplier range switch S102 and second multiplier range switch S103. The position of the multiplier range switches is determined by control A. Twelve h-f positions and one l-f

position of control A are available. The twelve h-f positions permit the selection of any output frequency within the frequency range 2000 kc to 18,100 kc, while the l-f position permits the selection of any output frequency within the frequency range of 200 kc to 600 kc.

(4) The 13 positions of Control "A" and the frequency range covered by each is given in table 4-1.

(5) HIGH FREQUENCY TUNING
CONTROL "A".

TABLE 4-1. FREQUENCY RANGE COVERED BY POSITIONS OF HIGH FREQUENCY TUNING CONTROL "A"

<i>Control "A" Position</i>	<i>Frequency Range</i>
1	2.0 to 2.4 mc
2	2.4 to 3.0 mc
3	3.0 to 3.6 mc
4	3.6 to 4.0 mc
5	4.0 to 4.8 mc
6	4.8 to 6.0 mc
7	6.0 to 7.2 mc
8	7.2 to 9.0 mc
9	9.0 to 10.8 mc
10	10.8 to 12.0 mc
11	12.0 to 14.4 mc
12	14.4 to 18.1 mc
13 (L.F.)	200 kc to 600 kc

In the first six positions of Control "A," only the first frequency multiplier tube, V102, is in operation. First multiplier range switch S102 connects the output circuit of the first frequency multiplier tube, V102, to the input circuit of the final amplifier tube, V104. With Control "A" in position 1 or 2, first multiplier tube V102 is operating as a frequency doubler. With control "A" in position 3 or 4, first multiplier tube V102 is operating as a frequency tripler. With control "A" in position 5 or 6, first multiplier tube V102 is operating as a frequency quadrupler. First multiplier range switch S102 is a twelve-position switch and connects padding capacitors across the first multiplier tube V102 plate tuning inductor, L105. The capacity of the tank circuit is reduced as control "A" is rotated in a clockwise direction, thus increasing the frequency of the output of first multiplier tube V102 as control "A" is rotated through positions 1 through 6. When control "A" is rotated to position 7, the second multiplier tube, V103, is placed in operation. First multiplier range switch S102 acts to connect the output circuit of first multiplier tube V102 to the grid circuit of second multiplier tube V103 and breaks the circuit from the first multiplier tube V102 output circuit to the grid circuit of final amplifier tube V104. The second multiplier tube, V103, operates only as a frequency tripler. Control "A" when in position 7 to 12 inclusive, also operates second multiplier operating switch S115 to connect the cathode of second multiplier tube V103 through bias resistor R129 to ground. The first multiplier tube, V102 operates as a frequency doubler when control "A" is in position 7 or 8, as a

frequency tripler when control "A" is in position 9 or 10, and as a frequency quadrupler when control "A" is in position 11 or 12. Second multiplier range switch section S103 connects the sections of padding capacitor C115 across the second multiplier tube V103 plate inductor, L106. Capacitors C111 and C115 are of the ceramic type and the capacity of each section may be adjusted by rotating one plate with respect to the other. The frequency multiplier stages are aligned by adjusting the capacity of C111 and C115 and the inductance of the plate tank inductors L105 and L106. The tuning slugs within inductors L105 and L106 are ganged with the tuning slug of L101, but may be adjusted in respect to each other and with respect to the tuning slug of L101, to obtain proper tracking within each frequency band. Plate and screen voltages for the frequency multiplier tubes, V102 and V103, are furnished by the low voltage section of the dynamotor. The voltage for application to the tube screens is dropped from the 400 volt output of the dynamotor to approximately 270 volts by dropping resistors R105 and R109.

(6) **POWER AMPLIFIER AND OUTPUT NETWORK.**—The power amplifier stage employs a Type JAN-813 beam pentode tube and operates as a straight amplifier at all frequencies. When the transmitter is operating in the frequency range 200 kc to 600 kc, the output of the l-f oscillator is capacitively coupled to the grid of the power amplifier (see fig. 4-13). When the transmitter is operating in the frequency range 2.0 mc to 6.0 mc the output of the first frequency multiplier tube, V102, is coupled to the grid of the power amplifier tube through first multiplier range switch S102 contacts and capacitor C116. When the transmitter is operating in the frequency range 6.0 mc to 18.1 mc the output of the second frequency multiplier tube, V103 is coupled to the grid of the final amplifier tube, V104, through second multiplier range switch contacts S103 and capacitor C116. When l-f operation has been selected output circuit selecting relay K105 operates to connect the plate circuit of the final amplifier tube, V104, to external loading coil terminal J117. With output circuit selecting relay K105 in the normal unoperated position the plate circuit of final amplifier tube V104 is connected to the output network that is incorporated in the transmitter proper. Voltage for the screen of power amplifier V104 is supplied by the low voltage section of the dynamotor. This voltage is applied through relay contacts K102F when the keying relay, K102, is operated. When the power level switch S106 is in the "CALIBRATE" position, screen voltage for V104 is removed and screen is connected to the control grid circuit through resistor R-137. This connection permits negative voltage on control grid to be applied to screen grid and thereby cuts off output from the power amplifier stage. If power level switch is in the "TUNE" position, screen voltage on V104 is reduced through series resistor R-124 to protect the tube from overload when transmitter is tuned. Full screen voltage is applied to V104 when switch S106

is in the "OPERATE" position.

(7) The operation of output circuit selecting relay K105 performs four functions, namely, (1) connects the output of the power amplifier to external loading coil terminal J117, (2) disconnects the antenna tuning and power amplifier plate tank circuit, (3) adds an additional r-f choke, in series with the power amplifier feed choke, L108, and (4) connects the positive 28 volt d-c lead to external relay connector J107 that connects to the "break-in" relay, K2501, in Antenna Loading Unit CU-32/ART-13A. When output control selecting relay K105 is in the normal or unoperated position, the output of the power amplifier tube is coupled to the plate tank and antenna coupling network in the transmitter proper through the capacitor C118. The r-f choke, L109, is shorted out. Full output voltage of the high voltage section of the dynamotor is applied to the plate of final amplifier tube V104.

(8) The output network is designed to operate as either a pi or L section. The multi-section output network switch, S113, connects the capacitors and inductors in the proper positions to permit matching the power amplifier plate circuit to most aircraft antennas at any frequency within the frequency range 2000 kc to 18,100 kc.

(9) Table 4-2 will help the operator to better understand the operation of switch S113.

(10) The variometer, L112, is operated by control D. The variable capacitor C125 is operated by control E. These network controls, C, D, and E are connected to the Autotune system, but may be manually operated without disturbing the positions of the Autotune stop rings if the "CHANNEL" selector switch, S108, is placed in the "MANUAL" position and the Autotune system allowed to operate. The network will tune and load to rated power with antennas 17 feet to 60 feet in length throughout the frequency range 3000 kc to 18,100 kc. If operation in the range 2000 kc to 3000 kc is desired, it may be necessary to connect Antenna Shunt Capacitor CU-24/ART-13 (fig. 1-8) across the network output to tune and deliver power to fixed aircraft antennas which are between 20 and 60 feet in length.

b. RADIO FREQUENCY CIRCUITS

RADIO TRANSMITTING SET AN/ART-13B.

Radio Transmitter T-412/ART-13B provides a choice of two combinations of r-f systems; one utilizing the master oscillator of the basic transmitter chassis; a second combination utilizing the Crystal-Controlled Oscillator CDA-T and the basic transmitter chassis. A change from one system to the other is accomplished by operating the "VFO-XTAL" switch on the CDA-T panel.

(1) **VFO OPERATION—HIGH FREQUENCY.**—This operation involving the use of the basic transmitter high frequency oscillator, V101, is always avail-

able regardless of whether the CDA-T is in use. When the CDA-T unit is used, the "VFO-XTAL" switch (S802) on its panel must be set on "VFO" to permit cathode grounding of the V101 oscillator circuit. All circuit details, as outlined in paragraph 2.g. (2) through (10), apply also to this operation.

(2) VFO OPERATION—LOW FREQUENCY.—This operation requires the use of Oscillator O-17/ART-13A. Circuit operation is outlined in paragraph 2.g. (1) of this section.

(3) CRYSTAL-CONTROLLED OPERATION—HIGH FREQUENCY.—The high frequency oscillator of the CDA-T unit, in conjunction with the frequency multiplier stages of the basic transmitter provide twenty crystal-controlled output frequencies in the range 1670 kc to 18,000 kc. Utilizing the autotune selection system and manually operated controls on the CDA-T panel, any one of these 20 preset frequencies may be selected without circuit readjustments.

(a) Utilizing a modified Pierce crystal oscillator circuit, this high frequency oscillator employs a Type JAN-6AQ5 tube (V801) and operates over the range of 1670 kc to 4000 kc. The output frequency of the oscillator will always be the frequency of the crystal in the circuit. The twenty crystals utilized to cover the above range are divided into two groups, "A" and "B", with ten crystals in each group. Group selection is accomplished by manually operating the "A-B" switch, S801, located on the CDA-T panel. This switch actuates the "A-B" relay (K811) which selects one group of crystals, shorting out the other group. Individual selec-

tion of crystals within a group functions through the autotune system, using positions 1 through 10 of the "CHANNEL" switch. When the autotune has cycled control "A" to the desired position, switch S109 which is mechanically coupled to the "A" control autotune motor, supplies relay operating voltage to one of the ten crystal relays (K801 through K810) which connects the selected crystal to the grid circuit of oscillator tube, V801. Oscillator operation is controlled by opening the cathode lead of V801 as previously described in this section, paragraph 2.d.(2A). Oscillator frequency range for each of the 12 positions of the "A" control are outlined in table 2-2.

(b) The output of the crystal oscillator is coupled through capacitor C150 and resistor R139 to the input of the First Frequency Multiplier stage. For transmitter output frequencies between 1.67 and 6.0 megacycles, this frequency multiplier stage couples directly to the Power Amplifier stage. For frequencies between 6.0 and 18.0 megacycles, the output of the First Frequency Multiplier stage is fed to the Second Frequency Multiplier. The First Frequency Multiplier operates as a straight through amplifier or as a frequency doubler, depending on the transmitter output frequency range desired. For positions 1 through 3 and 7 through 10 of the "A" control, it is an amplifier with its frequency output the same as the crystal. In positions 4 through 6, 11 and 12 of the "A" control, it is a frequency doubler, with its output frequency twice that of the crystal.

(c) The Second Frequency Multiplier stage always operates as a frequency tripler and is used for positions 7 through 12 of the "A" control. Its output couples to the Power Amplifier.

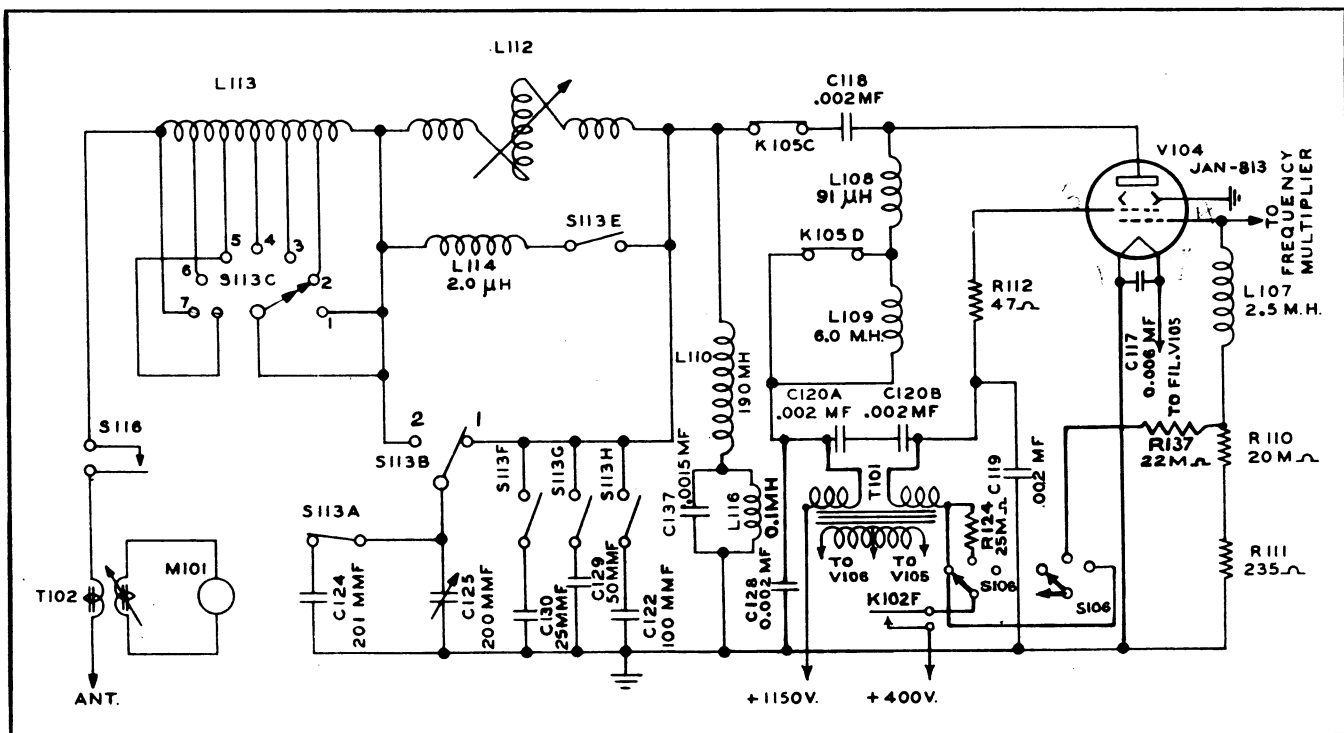

Figure 4-13. Power Amplifier and High Frequency Output Circuits

(d) All Power Amplifier and Output circuits operate exactly as outlined previously in paragraph 2.g.(6) of this section.

(4) CRYSTAL-CONTROLLED OPERATION—LOW FREQUENCY.—The low frequency oscillator of the CDA-T unit employs a Type JAN-1625 beam pentode tube V802 in a modified Pierce oscillator circuit to cover the frequency range of 300 to 500 kc. Three crystal sockets, one of which accommodates a dual type crystal holder, permit four channel low frequency operation. Switching from one frequency to another is accomplished through the 4-position rotary switch (S802) which shunts out all crystals not in use. An iron core plate choke (L803) may be varied to obtain resonance and provide maximum oscillator output. Screen and plate voltage for V802 is obtained from a tap on the dynamotor low voltage bleeder. Oscillator operation is controlled by opening the cathode lead of V802 as indicated in figure 4-5A. This cathode returns to ground through switch S114 (which is mechanically operated by the "A" control); through relay K106 (controlled by the "VFO-XTAL" switch S802), and finally through the keying relay contacts K102E. For low frequency operation, control "A" must be in position 13, which couples the oscillator output through the Second Multiplier range switch S103, to the grid of the Power Amplifier tube, V104. Frequency output of this oscillator is always the frequency of the crystal in the circuit.

3. THE AUTOTUNE SYSTEM.

The Collins Autotune System is an electrically controlled means of mechanically repositioning adjustable elements such as tap switches, variable inductors, variable capacitors, etc. Any combination of these items such as are used in transmitting equipment can be tuned to any one of eleven pre-selected frequencies in a period of 25 seconds at normal room temperatures and with a normal supply voltage, by the use of the Autotune system. Provisions have also been made to permit manual tuning of the transmitter.

a. MECHANICAL CHARACTERISTICS. — The Autotune assembly consists of a group of positioning mechanisms, one of which is applied to each tuning element to perform the same function as a manual tuning knob. Each positioning mechanism provides precise angular setting of the tuning control to any one of eleven angular positions, each of which is readily adjustable. The settings for each frequency and for each control are entirely independent.

(1) The positioning accuracy of the Autotune mechanism is of a very high order. Each setting is inherently independent of wear, backlash, alignment, supply voltage, etc. The accuracy of the settings is comparable to that of vernier manual controls. The parts are machined within close limits, and although operation is most precise, there are no delicate adjustments or fragile mechanisms. Permanently lubricated bearings are used in many places and the assembly is enclosed and protected from dust and corrosion.

(2) Some of the controls which are operated by the Autotune mechanism only require a maximum change in position of one revolution (360°) or less but the "Fine High Frequency Tuning Control B" may require as many as 20 revolutions to reach a particular setting. Thus, the Autotune system provides two basic types of mechanisms; one known as the "Singleturn Unit" and the other as the "Multiturn Unit." Singleturn Units are used to operate controls that make one turn or less to reach final setting. The Multiturn Unit is used to operate control B only, since that control may require up to 20 revolutions to reach final setting.

(3) IMPORTANT PARTS OF THE AUTOTUNE SYSTEM.—The names, descriptions, and functions performed by important parts of the Autotune mechanism are given in the following tabulation. Numbers that appear in parenthesis after the part names refer to the parts in figure 4-14.

(a) LINE SHAFT (1).—The line shaft extends the entire length of the Autotune casting and drives all

TABLE 4-2. FUNCTION OF MULTI-SECTION OUTPUT NETWORK SWITCH S113

Control "C" Position	S113A*	S113B	S113C	S113D**	S113E	S113F	S113G	S113H
1		1	1		OPEN	OPEN	OPEN	OPEN
2		1	2		OPEN	OPEN	OPEN	OPEN
3		1	3		OPEN	OPEN	OPEN	OPEN
4		1	4		OPEN	OPEN	OPEN	OPEN
5		1	5		OPEN	OPEN	OPEN	OPEN
6		1	6		OPEN	OPEN	OPEN	OPEN
7		1	7		OPEN	OPEN	OPEN	OPEN
8		2	7		OPEN	CLOSED	CLOSED	CLOSED
9		2	7		OPEN	OPEN	OPEN	CLOSED
10		2	7		OPEN	OPEN	CLOSED	OPEN
11		2	7		OPEN	CLOSED	OPEN	OPEN
12		2	7		OPEN	OPEN	OPEN	OPEN
13		2	7		CLOSED	OPEN	CLOSED	OPEN

*Operated by the rotation of C125. (Operated when Dial E reads in 0-100 range.)

**Operated by Control "C." Switch is closed when Control C is set to any of its 13 positions. As Control is rotated between positions, S113D opens and disables keying relay K102 thus preventing arcing at other switch contacts.

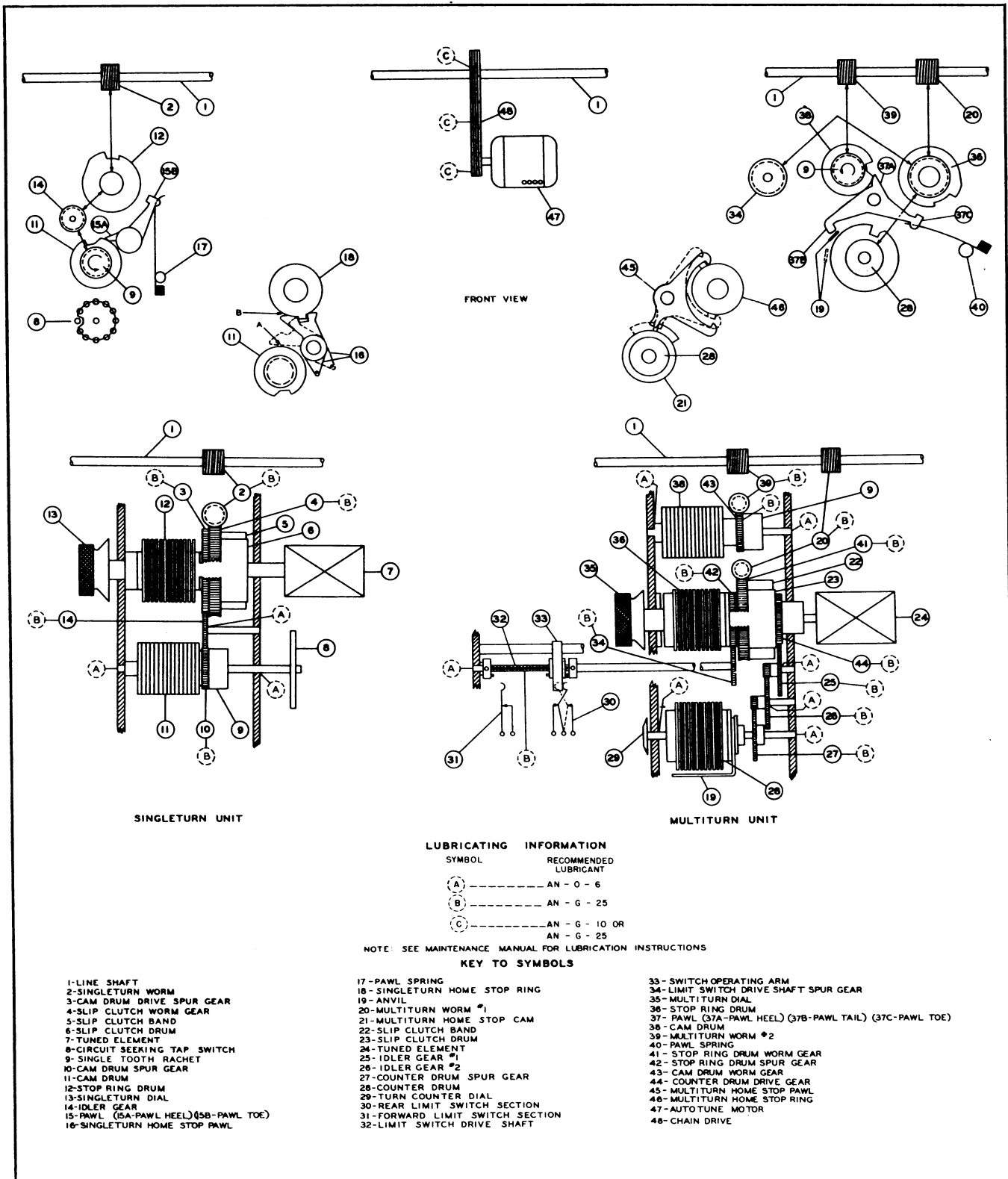

Figure 4-14. Autotune Mechanism — Mechanical Portion

the Autotune units. Power is applied to the shaft from the motor (47) by means of a chain drive (48).

(b) SINGLETURN WORM (2).—The singleturn unit is driven by one worm on the line shaft (1).

CAM DRUM DRIVE SPUR GEAR (3).—This gear is fastened directly to the slip clutch worm gear (4) and drives the cam drum spur gear (10) through the idler gear (14).

(c) SLIP CLUTCH WORM GEAR (4).—This gear is fastened to the cam drum drive spur gear (3) and drives the stop-ring drum (12) through the slip clutch (6). This gear is driven by the singleturn worm (2).

(d) SLIP CLUTCH BAND (5).—This band is driven directly from the slip clutch worm gear (4) and presses against the slip clutch drum (6).

(e) SLIP CLUTCH DRUM (6).—The slip clutch drum, driven by the slip clutch band (5), is fastened to the stop-ring drum shaft.

(f) TUNED ELEMENT (7).—The tuned element, such as a tap switch, a variable capacitor, or a variometer, is driven directly from the stop-ring drum shaft.

(g) CIRCUIT SEEKING TAP SWITCH (8).—This switch is driven by the cam drum shaft and is phased so that the contacts are in synchronization with the cams of the cam drums (11) and (38).

(h) SINGLE TOOTH RATCHET (9).—The single tooth ratchet, when engaged, drives the cam drum (11). These ratchets keep the cam drums of the various units synchronized.

(i) CAM DRUM SPUR GEAR (10).—The cam drum spur gear is driven from the line shaft through gears (2), (3), (4), and (14). The spur gear drives the cam drum (11) through the single tooth ratchet (9).

(j) CAM DRUM (11).—The cam drum consists of twelve cams mounted on a shaft with adjacent cam slots staggered 30 degrees. These cams are rigidly fastened to the drum. The single tooth ratchet (9) mounts on the shaft behind the drum and drives the drum.

(k) STOP-RING DRUM (12).—The stop-ring drum assembly consists of 12 stop rings mounted on a shaft with spacers between the rings. The stop rings are free to rotate but the spacers are keyed to the shaft so that as one stop ring is rotated, movement of the ring will not affect the adjacent rings which may have been previously adjusted. A locking bar, on the dial, locks the stop rings when adjustment has been completed. The locking mechanism consists of a bar that drives a screw to apply pressure to the stack of stop rings and spacers, thereby, in effect, locking them.

(l) SINGLETURN DIAL (13).—The singleturn dial is fastened to the stop-ring drum (12) and enables the operator to adjust the tuned element (7). The locking bar is located on the front of the dial.

(m) IDLER GEAR (14).—The idler gear transmits power from the cam drum drive spur gear (3) to the cam drum spur gear (10).

(n) PAWL HEEL (15A).—The pawl heel is held against the cam drum (11) by the pawl spring (17).

(o) PAWL TOE (15B).—The pawl toe serves to position the tuned element (7) by dropping into the stop-ring slot and stopping the stop-ring drum (12) after the motor (47) reverses and pawl heel (15A) is in a cam drum slot.

(p) SINGLETURN HOME STOP PAWL (16).—This pawl limits the rotation of the singleturn unit to one revolution. The pawl is located on the same shaft as the pawl (15) and is engaged by the singleturn home stop ring (18). Referring to the mechanical portion of the Autotune, the pawl as shown in solid lines limits the rotation of the stop-ring drum (12) in the counterclockwise direction. The pawl cannot pivot further because it bears against the stop-ring drum (12) at point "B." The pawl as shown in dotted lines limits the rotation of the cam drum (12) in a clockwise direction. The pawl cannot pivot further in this position because it bears on the cam drum (11) at point "A."

(q) PAWL SPRING (17).—The pawl spring presses the pawl heel (15A) against the cam drum (11) and when the pawl heel (15A) drops into the cam drum slot, the pawl spring presses the pawl toe (15B) against the stop-ring drum (12).

(r) SINGLETURN HOME STOP RING (18).—This ring, mounted with the other stop rings on the stop-ring drum (12), is rigidly fastened to the drum. The home stop pawl (16) engages with this ring to limit the rotation of the stop-ring drum (12) to one revolution.

(s) ANVIL (19).—The anvil prevents the multiturn pawl tails (37B) from becoming engaged in the counter drum (28) ring slots until after the motor (47) reverses.

(t) MULTITURN WORM NO. 1 (20).—This worm drives the stop-ring drum worm gear (41).

(u) MULTITURN HOME STOP CAM (21).—This cam is mounted with the other cams on the counter drum (28). It actuates the home stop pawl (45) to limit the rotation of the stop-ring drum (36) to 20 revolutions.

(v) SLIP CLUTCH BAND (22).—This band, driven by the worm gear (41) drives the stop-ring drum (36) through the slip clutch drum (23).

(w) SLIP CLUTCH (23).—This clutch, similar to (6), is driven by the slip clutch band (22) and is fastened to the stop-ring drum shaft.

(x) TUNED ELEMENT (24).—This frequency determining element is coupled directly to the stop-ring drum (36).

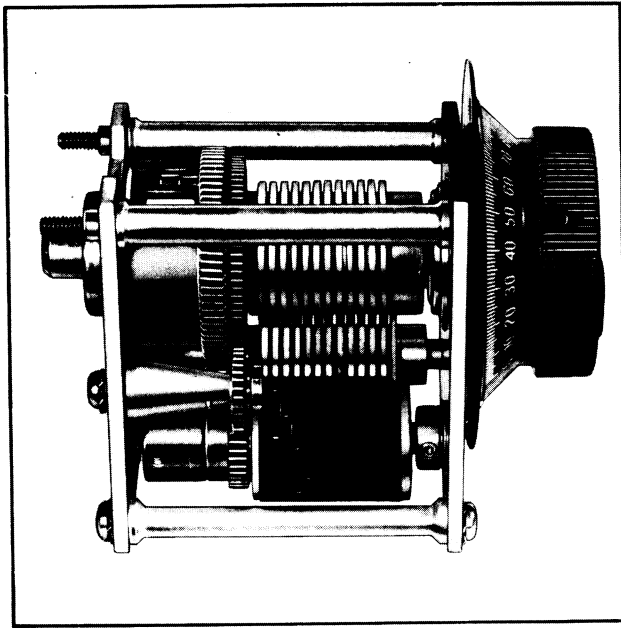

Figure 4-15. Singleturn Autotune Unit (Type 96J)—
Left Side View

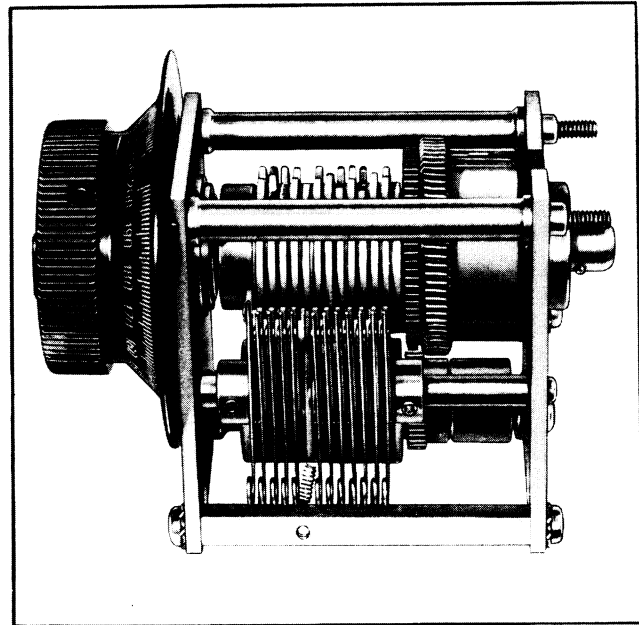

Figure 4-16. Singleturn Autotune Unit (Type 96J)—
Right Side View

Singleturn Autotune Units Operate Controls "A", "C", "D", and "E".

Unit No. 564080 Is Used to Operate Control "A".

Unit No. 564060 Is Used to Operate Control "C".

Unit No. 564070 Is Used to Operate Control "D".

Unit No. 564050 Is Used to Operate Control "E".

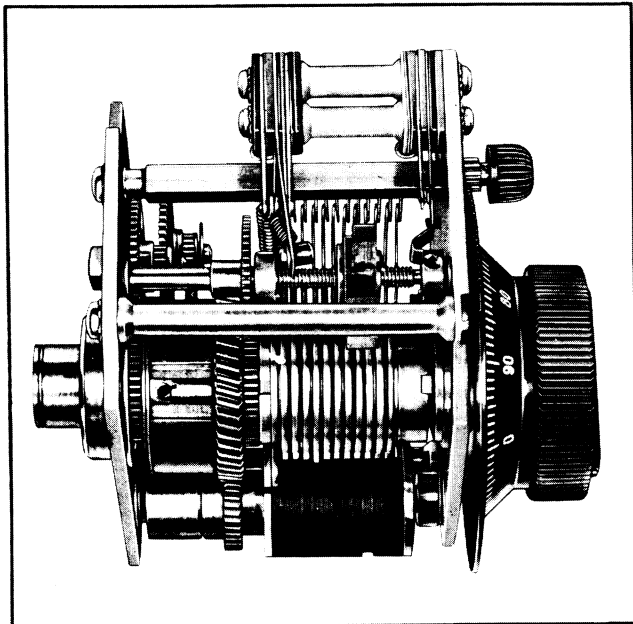

Figure 4-17. Multiturn Autotune Unit (Type 96K)—
Left Side View

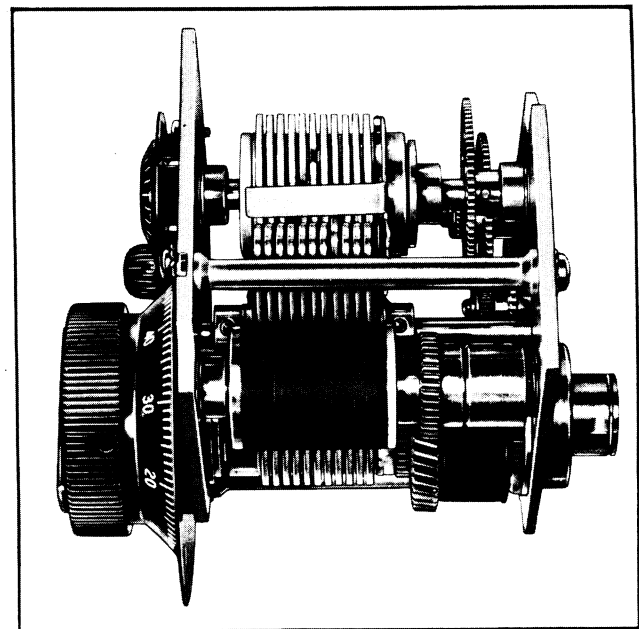

Figure 4-18. Multiturn Autotune Unit (Type 96K)—
Right Side View

Multiturn Autotune Unit No. 564090 Is Used to Operate Control "B".

Replacement Parts for the Autotune Are Listed in Table 5-7, Section V

IDLER GEAR NO. 1 (25).—This gear and gear (26) link the counter drum (28) to the slip clutch spur gear (44) which is fastened to the stop-ring drum (36).

(y) **IDLER GEAR NO. 2 (26).**—This gear and idler gear No. 1 (25) link the counter drum (28) to the slip clutch spur gear (44).

COUNTER DRUM SPUR GEAR (27).—This gear drives the counter drum (28).

COUNTER DRUM (28).—This drum consists of eleven cams with spacers between them. Like the stop-ring drums (12) and (36), the spacers are keyed to the shaft so that movement of one cam will not disturb adjacent cams. A spring on the rear of the counter drum loads the stack of cams axially so that the rings will not turn too easily.

(z) **TURN COUNTER DIAL (29).**—This dial, numbered from 0 to 20, indicates the number of turns the Multiturn unit has made.

(aa) **REAR LIMIT SWITCH SECTION (30).**—This switch, actuated by the operating arm (33), is normally held in the operated position. During the first part of the Autotune cycle, this switch opens, disabling the keying and dynamotor input relays. As the Autotune cycle nears completion, the operating arm (33) recloses the switch, turning off the motor (47) by restoring the motor torque retainer resistor to the circuit and restoring the coil circuits of the keying and dynamotor input relays.

(bb) **FRONT LIMIT SWITCH SECTION (31).**—This switch, normally closed, provides a holding circuit for the motor control relay. When the limit switch operating arm (33) opens the switch, the circuit seeking tap switch breaks the operating circuit of motor control relay K101, the unoperated position of which reverses the motor, thereby returning the limit switch operating arm to the original position, completing the cycle.

(cc) **LIMIT SWITCH DRIVE SHAFT (32).**—This shaft is driven by the gear (34) from the line shaft (1). The screw thread on the shaft moves the switch operating arm forward or backward between the limit switch sections (30) and (31). On either end of the screw are cams which limit the travel of the switch operating arm (33).

(dd) **SWITCH OPERATING ARM (33).**—This arm is driven by the threaded drive shaft (32) and controls limit switches (30) and (31).

LIMIT SWITCH DRIVE SHAFT SPUR GEAR (34).—This gear, driven by the stop-ring drum spur gear (42) drives the limit switch drive shaft (32).

(ee) **MULTITURN DIAL (35).**—This dial with locking bar enables the operator to adjust the stop-ring drum (36) to any desired operating frequency within the range of the equipment.

(ff) **STOP-RING DRUM (36).**—Same as Stop-Ring Drum, item (12).

(gg) **PAWL HEEL (37A).**—The pawl heel is held against the cam drum (38) by the pawl spring (40).

(hh) **PAWL TAIL (37B).**—The pawl tail, when allowed to engage the counter drum (28) ring slot by the movement of the anvil (19) selects the revolution in which the tuned element (24) will be positioned.

(ii) **PAWL TOE (37C).**—The pawl toe serves to position the tuned element (24) by dropping into the stop-ring slot and stopping the stop-ring drum (36).

(kk) **CAM DRUM (38).**—Same as Cam Drum, item (11).

(ll) **MULTITURN WORM NO. 2 (39).**—This worm drives the cam drum (38) through the single tooth ratchet (9).

(mm) **PAWL SPRING (40).**—This spring is similar to (17).

(nn) **STOP-RING DRUM WORM GEAR (41).**—This gear, powered from the line shaft (1) by the worm (20), drives the stop-ring drum (36) through the slip clutch (23).

(oo) **STOP-RING DRUM SPUR GEAR (42).**—This gear is fastened to the stop-ring drum worm gear (41) and drives the limit switch drive shaft (32) through the gear (34).

(pp) **CAM DRUM WORM GEAR (43).**—This gear, powered from the line shaft (1) by the worm (39) drives the cam drum (38) through the single tooth ratchet (9).

(qq) **COUNTER DRUM DRIVE GEAR (44).**—This gear, fastened to the slip clutch drum (23) drives the counter drum (28) through the idler gears (25) and (26) and gear (27).

(rr) **MULTITURN HOME STOP PAWL (45).**—This pawl, actuated to either position shown by the home stop cam (21), engages the projection on the home stop ring (46) to limit the rotation of the stop-ring drum (36) to 20 revolutions. This pawl is mounted on the same shaft as the pawl (37).

(ss) **MULTITURN HOME STOP RING (46).**—This ring is engaged by the pawl (45) and is mounted on the stop-ring drum (36). The dotted outlines of the home stop ring (46) and pawl (45) show the stop-ring drum (36) in the limit of rotation in the counterclockwise direction. The other position shows limit in the clockwise direction.

(tt) **AUTOTUNE MOTOR (47).**—The Autotune motor is a d-c shunt wound reversible type and applies power to the line shaft (1) through the chain drive (48).

(uu) **CHAIN DRIVE (48).**—The chain drive transmits power from the Autotune motor (47) to the line shaft (1) and consists of a driving pinion coupled to a driven sprocket by a chain.

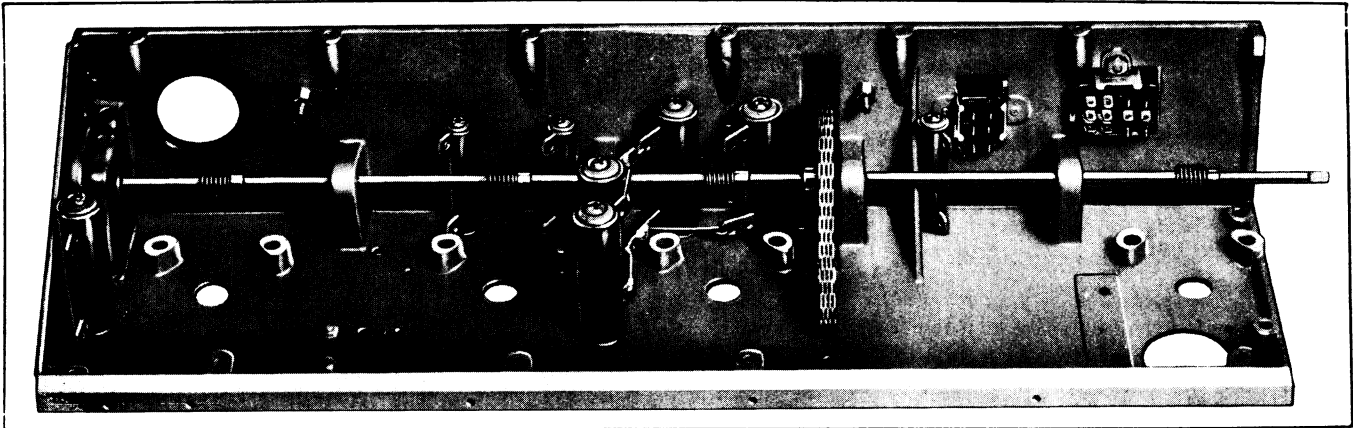

Figure 4-19. Autotune Casting
(See Table 5-7, Section V, for list of replaceable parts)

(See Table 5-7, section V, for list of replaceable parts.)

b. ELECTRICAL CHARACTERISTICS.—The following electrical components are used in conjunction with the Autotune System as a source of motive power and for electrical control of the mechanical functions. Interconnection of these electrical parts is shown in figure 4-20.

(1) **AUTOTUNE MOTOR B101.**—The Autotune motor operates from the 28 volt direct current power source and is controlled by the limit switches, S111 and S112, and motor control relay, K101.

(2) **MOTOR CONTROL RELAY K101.**—K101 is energized through the contacts of the keying relay, K102, the "LOCAL-REMOTE" switch, S107, the "CHANNEL" selector switch, S108, and the circuit

seeking tap switch S109, to ground (Br. Earth). The holding circuit for the relay is through contacts 5 and 6 of motor control relay K101 and the contacts of front limit switch section, S112. When operated, motor control relay K101 disables keying relay K102 and dynamotor input relay K2703 preparatory to the release of rear limit switch section S111.

(3) **KEYING RELAY K102.**—When K102 is operated during periods of transmission, it prevents false operation of the Autotune System by opening the circuit to motor control relay K101. The energizing circuit is through the "EMISSION" control circuits; that is, the "TEST" switch, S104, the Throttle Switch Jack J101, the "MICROPHONE" Jack J102, or the "KEY" jack J103.

(4) **LOCAL-REMOTE SWITCH S107.**—This switch provides for selection of control either from the

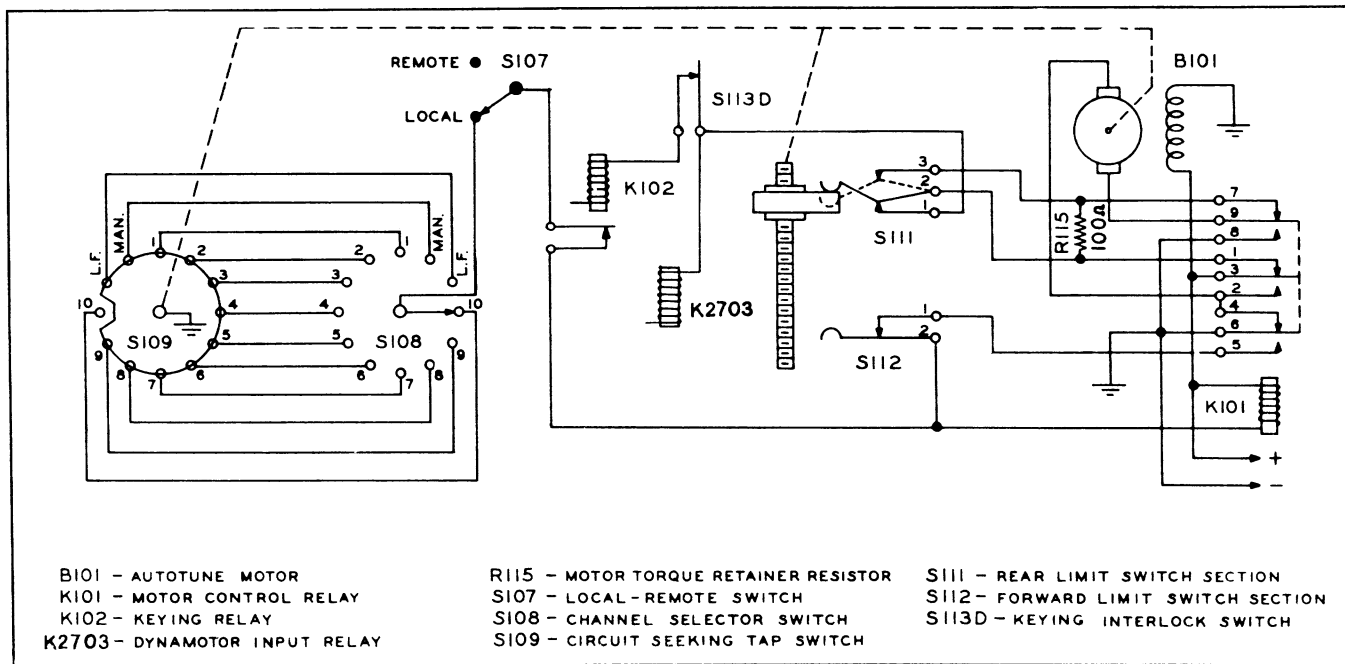

Figure 4-20. Electrical Portion of Autotune System

front panel of the transmitter or from the remote control unit. The switch is located on the transmitter panel and is designed for manual operation only.

(5) CHANNEL SELECTING SWITCH S108.— This switch permits the selection of any one of ten high-frequency Autotune channels, one low-frequency channel and "MANUAL" tuning of the transmitter. It completes the circuit to ground (Br. Earth) necessary for the operation of the motor control relay K101.

(6) CIRCUIT SEEKING TAP SWITCH S109.— This switch is driven by the Autotune motor, B101, through a worm and spur gear arrangement. The circuit seeking tap switch, S109, completes the circuit necessary for the operation of the motor control relay, K101. Of the 12 circuits connected to the circuit seeking tap switch, S109, 11 are grounded (Br. Earthed) at all times. The operation of motor control relay K101 connects front limit switch section S112 in the circuit, preventing seeking switch S109 from finding the circuit selected by "CHANNEL" selecting switch S108 until after the limit switch operating arm reaches and operates front limit switch section S112.

In the AN/ART-13B, S109 is comprised of two wafer decks, the first one as described above and performing the functions already outlined; and a second wafer (single-pole 10-position) whose function is to select the required crystal(s) for each of the ten high frequency channel positions, when using crystal-controlled operation. This selection is accomplished by switching primary power, in turn, to each of the crystal relays (K801 through K810) as the "CHANNEL" switch and S109 move to the desired high frequency channel. Further selection of crystals is determined by the "A-B" switch.

(7) REAR LIMIT SWITCH SECTION S111.— S111 is normally held in the operated position to complete the circuit necessary for the operation of keying relay, K102 and dynamotor input relay K2703. When released by the limit switch operating arm, contacts 2 and 3 of the rear limit switch section, S111, short motor torque retainer resistor R115 out of the circuit preparatory to the release of motor control relay K101. The return of the limit switch operating arm to the original position opens contacts 2 and 3 of rear limit switch S111, placing motor torque retainer resistor R115 again in the circuit, thereby stopping Autotune motor B101.

(8) FRONT LIMIT SWITCH SECTION S112.— The normally closed contacts of S112 complete the holding circuit for motor control relay K101 through contacts 5 and 6 of K101. When the front limit switch section, S112, is operated by the switch operating arm, allowing circuit seeking tap switch S109 to find the circuit position selected by "CHANNEL" selecting switch S109, the operating circuit for motor control relay K101 is broken allowing K101 to release. The return of motor control relay K101 to the unoperated position reverses the direction of rotation of the Autotune motor, B101.

(9) KEYING INTERLOCK SWITCH S113D.—

This switch is operated by the "ANTENNA TUNING—COARSE," control C, and prevents the operation of the keying relay, K102, between settings of control C when "LOCAL-REMOTE" switch S107 is in the "LOCAL" position.

c. OPERATION CYCLE OF AUTOTUNE MECHANISM.—The Autotune system consists of one Multiturn unit and several Singleturn units (see figs. 4-15, 4-16, 4-17, 4-18, and 4-19) which are driven by a reversible motor through a line shaft. The Multiturn unit may be set up to select any dial setting in a continuous range of 7200 angular degrees (20 turns or revolutions) of dial rotation.

Note

One revolution of the dial is equal to 360 angular degrees of rotation. The Singleturn units may be set up to select any dial setting from 0 to 360 degrees of rotation (a single turn or revolution).

(1) The drawings of the electrical and mechanical portions of the Autotune, figure 4-20 and figure 4-14, should be referred to in connection with the following description of the operational sequence. The drawings show the Autotune mechanism in the rest position at the completion of the operation cycle.

(2) The following sequence of operations, listed in order, represents the complete Autotune cycle:

(a) The operator turns the CHANNEL selector switch S108, to the channel desired.

(b) This places a ground (Br. Earth) on the motor control relay, K101, through the circuit seeking tap switch, S109, the "CHANNEL" selector switch, S108, the "LOCAL-REMOTE" switch, S107, and the contacts of the keying relay, K102. With the keying relay, K102, in the normal or unoperated position, the motor control relay, K101, will operate and energize the Autotune motor, B101. The motor control relay, K101, is then kept energized by the circuit through contacts 5 and 6 and the limit switch section, S112. The operation of motor control relay, K101, disables the keying relay K102.

(c) The motor, B101, drives the line shaft (1) in a forward direction causing all the cam drums and stop-ring drums to rotate in a counterclockwise direction and the multiturn unit counter drum to rotate in a clockwise direction.

(d) The switch operating arm (33) moves out from the rear limit switch section, S111 and moves toward the forward limit switch section S112. Contacts No. 1 and No. 2 of the rear limit switch section, S111, open, keeping keying relay K102 and dynamotor input relay K2703 disabled when the motor control relay, K101, opens. Contacts No. 2 and No. 3 of the rear limit switch section short motor torque resistor R115 out of the circuit preparatory to the release of motor control relay K101.

(e) The forward limit switch section, S112, opens and the motor continues to run until the open

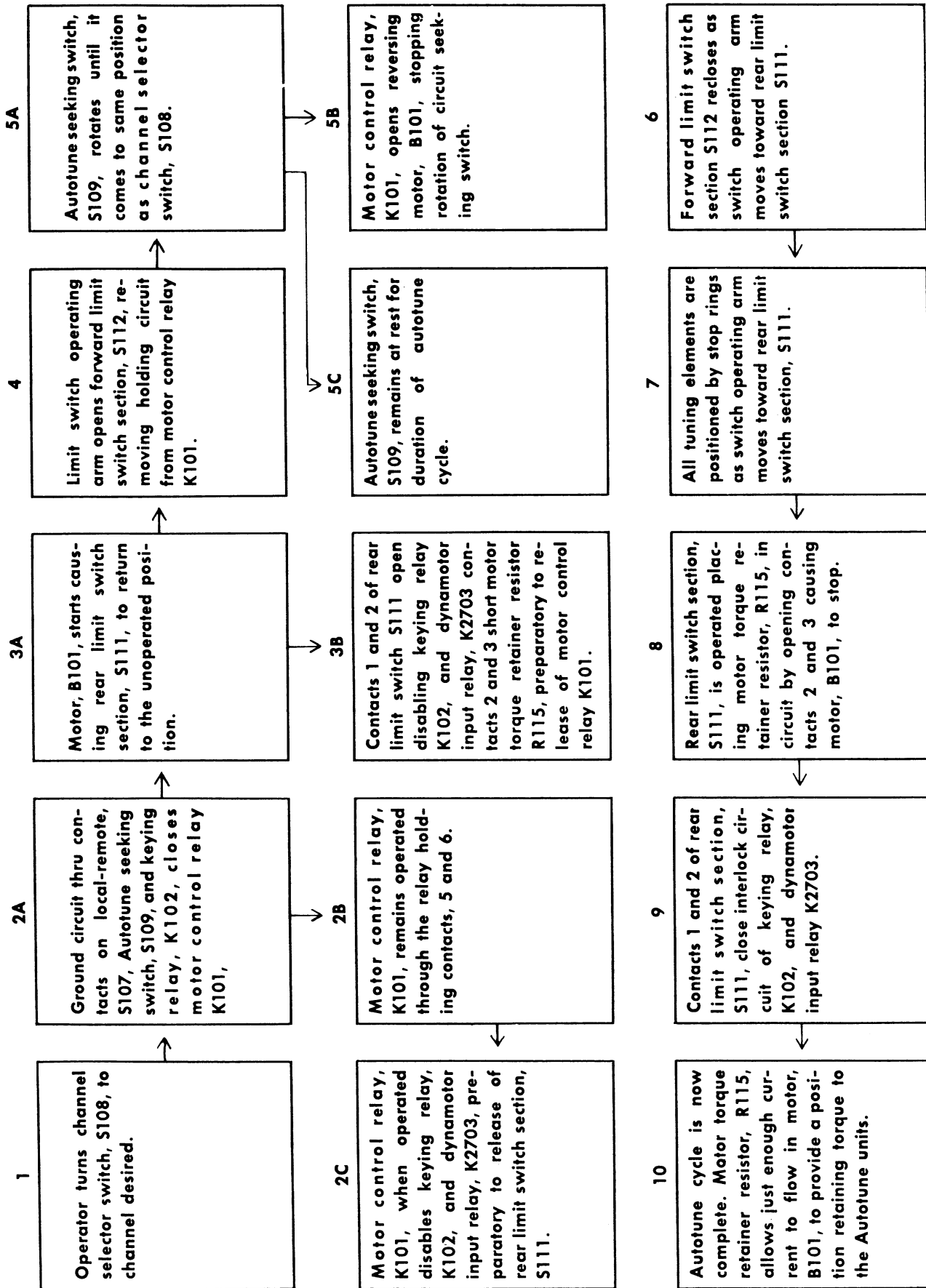

Figure 4-21. Sequence of Autotune Operation

segment of the circuit seeking tap switch, S109, is positioned opposite the contact upon which the channel selector switch has been set by the operator.

(f) As the open segment of the seeking tap switch, S109, comes to the contact of the channel selected, the synchronized cam drums are at the position where the pawl heels (15A and 37A) of the channel selected have just dropped into their respective slots in the cam drums.

(g) Since the holding circuit has been removed, the motor control relay, K101, opens, causing the polarity of the voltage on the armature to be reversed. The motor reverses direction of rotation.

(h) After the motor reverses, allowing the cam drums to fully engage their respective pawl heels, the switch operating arm moves toward the rear, allowing the forward limit switch section, S112, to reclose.

(i) As the motor continues to run in a reverse direction, the stop-ring drum (12) of the singleturn unit rotates and when the slot on the stop ring of the channel selected is adjacent to pawl toe (15B) the pawl toe drops into the slot. The pawl toe stops the tuned element (7) at the predetermined position and the clutch slips until the Autotune cycle has been completed.

(j) Also, as the motor runs in the reverse direction, the counter drum (28) of the multiturn unit reverses direction of rotation thereby rotating the anvil (19) out from under the pawl tail (37B) and when the slot of the cam on the counter drum, of the channel selected, is adjacent to the pawl tail (37B), the pawl tail drops into the slot and selects the revolution in which the tuned element (24) will be positioned.

(k) As soon as the slot in the proper stop ring of the stop-ring drum (36) is adjacent to the pawl toe (37C) the pawl toe drops into the slot. This stops the tuned element (24) at the preselected position and the clutch (23) slips until the Autotune cycle has been completed.

(l) As the motor continues in the reverse direction, the switch operating arm moves back against the rear limit switch section, S111, opening contacts No. 2 and No. 3 of S111.

(m) Contacts No. 2 and No. 3 of the rear limit switch section upon opening remove the short across the motor torque retainer resistor, R115, which stops the motor by allowing just enough current to flow through the armature of motor B101, to provide a position retaining torque to the Autotune units.

(n) The contacts No. 1 and No. 2 of the rear limit switch section, S111, close permitting the carrier to be turned on. The Autotune cycle is now complete. The carrier control circuits and Autotune control circuits are interlocked so that the Autotune will not operate when the carrier is on and the carrier cannot be turned on while the autotune system is in operation.

d. FUNCTIONS PERFORMED BY THE AUTOTUNE SYSTEM.—The entire Autotune System utilizes one multiturn Autotune mechanism and four

singleturn Autotune mechanisms to automatically operate transmitter controls "A," "B," "C," "D," and "E." Control "B" requires the use of a multiturn mechanism as this dial may be rotated through 20 complete revolutions. Other controls are operated by the singleturn mechanisms.

(1) Functions performed by each Autotune unit are described in the following paragraphs. Each of the five individual Autotune units are referred to by the same letter that is used to designate the control on the panel of the transmitter; for example, Autotune unit "A" is used to operate control "A" etc.

(2) AUTOTUNE UNIT "A."—This unit is a singleturn mechanism that operates control knob "A" to accomplish the following:

(a) Selects high or low frequency oscillator.

(b) Selects high frequency oscillator range.

(c) Selects multiplier range.

(d) Operates Autotune circuit seeking switch S109.

The above functions are performed by means of directly operated and cam operated switches which are located in the multiplier chassis and in the high frequency oscillator chassis. Range of first multiplier stage is controlled by the switch wafer nearest to Autotune Unit "A." Range of second multiplier stage is controlled by switch wafer farthest from Autotune Unit "A." A cam operated multi-contact switch selects either low or high frequency oscillator and actuates relay K105 to select correct output circuit for power amplifier stage. Another cam operated switch closes the cathode of the second multiplier stage when that stage is required. The one remaining cam is star shaped and is used to actuate a switch located in the adjacent high frequency oscillator casting; this switch being used to select desired high frequency oscillator range.

(3) AUTOTUNE UNIT "B."—This unit is a multiturn mechanism that operates control knob "B" to accomplish the following:

(a) Fine tuning of high frequency oscillator.

(b) Fine tuning of both multiplier stages.

The above functions are performed by moving the tuning slugs in inductors L101, L105 and L106. These three inductors are located on the high frequency oscillator casting and are ganged so that they are all operated simultaneously by control knob "B" or Autotune unit "B."

(4) AUTOTUNE UNIT "C."—This unit is a singleturn mechanism that operates control knob "C" to accomplish the following:

(a) Coarse selection of inductance for antenna tuning circuits (in transmitter).

(b) Coarse selection of capacity for antenna tuning circuits (in transmitter).

These functions are performed by operation of the multi-element network switch sections S113B, S113C, and S113E. The switch is operated directly by

control "C" or Autotune Unit "C." In the first position of the switch all of the inductance L113 is in the circuit and when position seven is reached, the inductance L113 is completely shorted out. L113 remains shorted out in positions seven through 13. Between positions seven and eight, a switch operates to cut in ceramic padding capacitors, various combinations of which are used in positions eight through 13. In addition a small inductance L114 is connected across variometer L112 in position 13 by operation of one of the switch arms. A star cam on the same network switch shaft operates switch S113D that disables the r-f portion of the complete transmitter by preventing the operation of keying relay K102 when control

knob is between switch settings.

(5) AUTOTUNE UNIT "D."—This unit is a singleturn mechanism that operates control knob "D" to accomplish the following: operates variometer L112 to provide fine inductance tuning of the antenna circuit.

(6) AUTOTUNE UNIT "E."—This unit is a singleturn mechanism that operates control knob "E" to accomplish the following: operates variable capacitor C125 and switch section S113A to provide fine control of capacitance in the antenna loading circuits (in transmitter). Operation of switch section S113A connects a fixed capacitor C124 in parallel with variable capacitor C125 to extend the range.

SECTION V MAINTENANCE

IMPORTANT

Periodic inspections prescribed herein represent minimum requirements. If because of local conditions, peculiarities of equipment, or abnormal usage they are found insufficient to assure satisfactory operation of the equipment, local authorities should not hesitate to increase their scope of frequency.

1. INSPECTIONS.

In order to insure dependable operation, the equipment must be briefly inspected before each flight. More thorough inspections are required daily and after an interval of 100 hours of operation. Detailed procedures for each type of inspection are presented in the following paragraphs.

a. PRE-FLIGHT INSPECTION.—The radio transmitting equipment shall be given a rapid visual and operating inspection in accordance with the following:

- (1) Inspect antenna for proper security and tension. Check condition of shock links and antenna wire, cleaning if dirty and replacing if defective. Clean insulators and replace if cracked or chipped.
- (2) Make a visual check for proper security of all set components.
- (3) Turn on the liaison receiver.
- (4) Place EMISSION switch on "VOICE" with LOCAL-REMOTE switch on "LOCAL". In Model AN/ART-13B, the VFO-XTAL switch should be set at VFO or XTAL, depending on the type of operation desired.
- (5) Place CHANNEL switch on a position corresponding to one of the frequencies to be used on the mission.
- (6) When the cycle is completed, check the settings of controls "A," "B," "C," "D," and "E" against

readings on the transmitter chart with the indicating mark on "B" previously set so that the zero line is directly above the dial.

(7) Make sure the microphone selector switch is in the position corresponding to the type of microphone to be used.

(8) Be sure the meter switch is on "P.A. PLATE" and the power level switch is on "OPERATE."

(9) Place EMISSION switch on "CW" and close TEST switch. The plate current should read in the area marked "P.A. PLATE."

(10) Place the meter switch on "P.A. GRID." The meter should read in the area marked "P.A. GRID." Release "TEST" switch and place the meter switch on "P.A. PLATE". In Model AN/ART-13B, when "XTAL" operation is used, the P.A. GRID reading will be lower than for "VFO" operation. Normal meter indication will be just under the area marked "P.A. GRID".

(11) Place "EMISSION" switch on "MCW."

(12) Listen in the sidetone circuit and close "TEST" switch. The receiver hiss should stop and the sidetone signal should be heard. The plate current should be in or near the area marked "MCW." Release "TEST" switch.

(13) Place "EMISSION" switch on "VOICE." Press the microphone button. The plate current should read about 20 or 30 higher than on "CW." Speak or whistle into the microphone. The plate current should read near the area marked "MCW," and may read full scale on loud signals.

(14) Check the control settings, "P.A. GRID" current and "P.A. PLATE" current on "CW" for each of the other channels it is desired to use on the mission. Connect the proper number of sections of the shunt capacitor for the channels requiring them as indicated on the chart. (See par. 6.b. (2) (jj) of sec. II.)

b. **DAILY INSPECTION.**—The radio transmitting equipment shall be given a thorough visual and operational inspection in accordance with the following:

(1) Inspect as directed in paragraph 1.*a.*(1) and (2), this section. In addition check all interconnecting cables and wires. Be sure all cable plug locking rings are tight and tie wired in place.

(2) Check the connections to the receiver, antenna, ground, and loading unit, making certain the spring connector terminals are making good contact with the wires.

(3) **OPERATIONAL CHECK OF AUTOTUNE OPERATION.**

(*a*) Place the power level switch in "TUNE" position and "EMISSION" switch in "VOICE" position.

(*b*) Beginning with channel 1, operate "CHANNEL" selector switch to each of the 10 high-frequency channels that are tuned. As each autotune cycle is completed, check the positions of the controls against the original settings as shown on the chart with the indicating mark on control B previously set so that the zero line is directly above the dial.

(*c*) Having checked the positioning of the high-frequency channels in use, operate "CHANNEL" switch to "L. FREQ." position.

(*d*) When the autotune cycle has been completed, control A should come to rest on position 13 and control C on 8.

(*e*) Assuming that autotune positions are correct for the tuned channels, operate "CHANNEL" switch to "MANUAL" position. "MANUAL" operation is possible only in Model AN/ART-13A and "VFO" operation of Model AN/ART-13B. "XTAL" operation of the latter model utilizes only autotune selection.

(*f*) When the autotune cycle has been completed, check the operation of all controls. Each control should move freely to permit transmitter tuning without disturbing the positions of the autotune stop rings.

(4) **CHECK OF POWER CONTROL, R-F AND AUDIO CIRCUITS.**

(*a*) Operate "LOCAL-REMOTE" switch to "LOCAL" position and "EMISSION" switch to "CW" position.

(*b*) Rotate the meter switch to the "P.A. PLATE" position.

(*c*) Close "TEST" switch.

(*d*) Check the power amplifier plate reading on the meter. The meter should indicate within the "CW" portion of the meter scale.

(*e*) If the meter does not indicate a "P.A. PLATE" meter reading within the "CW" portion of the scale, some adjustment of the output loading may be necessary. Before attempting to readjust the output circuit for proper loading for the particular channel upon which the transmitter is operating, check the

operation on the other tuned autotune channels by operating "CHANNEL" switch.

(*f*) If all meter readings are off in the same direction, that is, if all readings are too high or if all readings are too low, check the battery voltage by operating the meter switch to "BATTERY-VOLTAGE" position.

(*g*) If the battery voltage is much higher or lower than the voltage was at the time the tuning adjustments were made and the autotune stop rings locked, the power amplifier plate meter reading will be somewhat different than the original reading. No adjustment of the output tuning controls should be attempted if the tuning adjustments were originally made with normal supply voltage.

(*h*) Check the keying by operating the telegraph key and listening to the keyed signal in the headphones. The transmitter should key cleanly and without noticeable chirp at speeds up to thirty words per minute.

(*i*) Release the telegraph key and operate "EMISSION" switch to "MCW" position.

(*j*) Close "TEST" switch.

(*k*) Check the "P.A. PLATE" meter reading on the meter. The meter should indicate within the "MCW" portion of the meter scale.

(*l*) Release "TEST" switch and listen in the earphones.

(*m*) Operate "EMISSION" switch to "VOICE" position.

(*n*) Press the "PUSH-TO-TALK" button on the microphone and check the "P.A. PLATE" meter reading. It should read about 20 or 30 higher than on "CW."

(*o*) Speak or whistle into the microphone and check the swing of the needle of the meter. The needle should swing up to the "MCW" portion of the meter scale, or slightly beyond, on voice peaks.

(*p*) Check operation of the speech amplifier by listening to the sidetone amplifier output while speaking into the microphone.

When operation from the transmitter panel has been checked, the procedure outlined below should be followed to check remote operation:

(*q*) Operate "LOCAL-REMOTE" switch to "REMOTE" position.

(*r*) Operate the "EMISSION" selector switch on the remote control unit to "VOICE" position.

(*s*) Following the procedure outlined for checking the autotune system from the transmitter panel, check operation and positioning of the dials when using remote "CHANNEL" switch. The position of the controls for a given autotune channel selected with the remote control unit should correspond to the position of the controls when the autotune channel is selected with the transmitter panel switch. For "XTAL" operation of AN/ART-13B from the remote position, using two crystals on one or more of the ten high frequency

channels, the remote "A-B" switch must be operated to select the desired crystal. With the CHANNEL switch of the remote control in "L.FREQ." position, only one of the low crystal frequencies is available, depending on the setting of the 4-position low frequency selector switch on the CDA-T unit.

(t) Using a microphone at the remote position, check the transmitter control by operating the "PUSH-TO-TALK" button on the microphone. Also check the condition of the audio lines from the control unit to the transmitter by speaking into the microphone and checking the kick of the needle of plate meter. Voice peak readings should correspond to reading obtained when checking the modulation at the transmitter panel.

(u) Operate the "EMISSION" switch to "CW" position and momentarily operate the key on remote control unit. Check the keying by listening to the sidetone.

(v) Operate the "EMISSION" switch to "MCW" position and check "P.A. PLATE" by observing plate meter. Check the keying by listening to the sidetone.

(w) If the above checks reveal erratic or abnormal operation, the tubes should be carefully checked. Tube failure is probably the most common cause of transmitter failure. The most dependable method of checking the tubes and finding the defective tube is to replace the tubes, one at a time, with tubes known to be in good condition.

(x) In order to gain access to the tubes and other components, the transmitter cover must be removed. This can be done by inserting a coin or a screw driver in the holddown screws, making a half turn counterclockwise and lifting off the cover.

c. 100-HOUR INSPECTION.—The radio transmitting equipment shall be given a thorough and searching visual and operating inspection in accordance with the following:

(1) Inspect as directed in paragraph 1.b.(1) and (2) in this section. Remove and disassemble all plugs and inspect wires for breaks and loose wires at the plugs. Inspect all cables.

(2) PREPARATION FOR INSPECTION.—Remove the transmitter, dynamotor unit, and antenna loading unit as follows:

(a) To remove the transmitter loosen the wires from the five terminals on the left hand end of the transmitter and also remove the three electrical plugs. Remove the safety wire from and loosen the locking knobs located on the front edge of the transmitter by turning them counterclockwise. Slide the transmitter forward approximately two inches and lift off the mounting.

(b) To remove the dynamotor, remove the two electrical plugs and remove the safety wire from the locking knobs. Loosen the knobs by turning counterclockwise until the clamps rotate a fraction of a turn and the base plate is released.

(c) To remove the antenna loading unit, remove all wires and plugs. Loosen the four snap slides and remove the unit.

(3) TRANSMITTER INSPECTION.—Remove the cover from the transmitter and inspect the interior for loose leads, corrosion, or other obvious defects. Clean out all dust and dirt, particularly around isolanite bushings, standoff feed through insulators, etc. Check all tubes for proper seating, and check plate leads and tube locking clamps for tightness. Inspect all relay contacts.

(4) DYNAMOTOR INSPECTION.—Remove the dynamotor end covers, and using compressed air, blow out all carbon dust and copper dust from the commutator and surrounding surfaces. Inspect the brushes and commutators for wear and replace the brushes if they are shorter than 1/4 inch. Clean the commutators with carbon tetrachloride and a cloth. Smooth the commutators with 00 sandpaper if they are rough. No lubrication of the dynamotor bearings is necessary. The bearings are sealed for the life of the unit. Remove the bottom plate and inspect the relay contacts for pits and burrs. Remove the fuse cover and inspect the fuse for corrosion. Replace the end covers.

(5) ANTENNA LOADING UNIT.—Remove all dust and dirt. Inspect switch contacts and remove any corrosion found.

(6) REINSTALLATION.—Reinstall the transmitter, dynamotor unit, and antenna loading unit on their mounts. Connect all electrical plugs and wires and replace all screws. Safety wire the transmitter and dynamotor units and all connecting plug locking rings. To prevent corona discharge from the antenna leads, do not allow any sharp ends of the leads to project from the binding post terminals. Make sure proper spacing is provided between all antenna wires and ground.

(7) Make operational check as directed in paragraph 1.b.(3) and (4) in this section.

2. TROUBLE SHOOTING IN THE PLANE.

When symptoms of unsatisfactory operation are noted, certain observations and simple tests can usually be performed to quickly determine the approximate location and nature of the fault. By first looking for the most common causes of transmitter failure and then correcting those faults that only require repair or replacement of easily accessible items, the need for removing the equipment from the aircraft can be avoided. Therefore, the trouble-shooting procedure given in the following paragraphs and in table 5-1, may be performed while the equipment is installed in the plane and does not require any specialized knowledge of the internal circuits of the equipment. If it is found that the fault cannot be corrected by these simple procedures, the major unit in which the trouble is located may be removed so that more involved trouble-shooting methods may be applied at the repair station. Trouble-shooting methods for faults of the type that

can only be corrected at the repair station are given in paragraph 3 and table 5-2, this section.

a. **SIMPLIFIED TROUBLE SHOOTING ON INSTALLED EQUIPMENT.**—The more common causes of transmitter failure, that are most easily corrected, are as follows:

- (1) Loose connection at plug on one or more of the interconnecting cables or antenna leads.
- (2) No power available at the 28-volt d-c power lines in the plane, caused by loose connections or open circuit breaker in the power line.
- (3) Blown fuse in the equipment.

- (4) Faulty tubes.
- (5) Worn brushes in the dynamotor.

(6) Protective overload relays on the Dynamotor Power Unit have opened because of an overload somewhere in the equipment.

Whenever any of the above faults occur, peculiarities in the performance of the equipment will generally be noted. If these peculiarities or symptoms are recognized as being caused by a particular fault, the problem of locating the fault is immediately solved. Table 5-1 has been prepared to show the symptoms produced by these more common causes of failure. Location of the fault, as well as the remedy to be applied, is given in each instance.

TABLE 5-1. TROUBLE SHOOTING ON INSTALLED EQUIPMENT

Faults That Prevent Operation of Entire Equipment

<i>Symptoms</i>	<i>Probable Cause of Trouble</i>	<i>Remedy</i>
1. Equipment will not operate when turned on.	1a. If red indicator lamp is on, but dynamotor does not operate when EMISSION switch is set to CW or MCW, then overload relay on dynamotor unit may be open, or dynamotor brushes may be worn out.	1a. Reset overload relay on dynamotor unit by pressing button marked "DYNA-RESET." If dynamotor starts momentarily and overload relay opens again, see Symptom No. 3. If dynamotor does not start, remove end cover and check brushes and commutator. Brushes that are worn down to 1/4" or less in length, should be replaced. Copper dust on commutator should be blown out with air stream. Commutator may be cleaned with carbon tetrachloride and a cloth; <i>never use emery cloth.</i> If dynamotor does not start, see Symptom No. 2.
	1b. If red indicator light is off, LOCAL-REMOTE switch may be set to "REMOTE" position. Transmitter cannot be turned on or off at transmitter panel when switch is in "REMOTE" position.	1b. Set LOCAL-REMOTE switch to "LOCAL" position. If transmitter still will not operate and red indicator light is still off, see Cause No. 1c.
	1c. If red indicator lamp is off, and LOCAL-REMOTE switch is in LOCAL position, then the transmitter overload relay (and possibly the dynamotor overload relay as well) may be open.	1c. Reset both overload relays on dynamotor unit by pressing buttons marked "TRAN. RESET" and "DYNA. RESET." If red indicator lamp turns on momentarily and then goes out again, see Symptom No. 3. If lamp does not turn on at all, see Symptom No. 2.
	1d. If red indicator lamp is on and dynamotor operates but no R-F output is obtained, see Symptom No. 4.	1d. Remedy opposite Symptom No. 4 should be applied.
2. Red indicator light or dynamotor will not operate even after overload relay "RESET" buttons on Dynamotor Unit have been pressed. EMISSION switch must be in CW or MCW position when this symptom is checked. If equipment operates momentarily when "RESET" buttons are pressed, see Symptom No. 3.	2a. Loose connection at plugs U-10/U, U-9/U, U-8/U, U-7/U or U-6/U.	2a. Check plug connections to be sure all are making good contact.
	2b. No power available at 28 volt D.C. power line to which equipment is connected.	2b. Note whether other equipment connected to same power line will operate. If other equipment operates, check for loose connection at points where AN/ART-13A equipment connects to the power line. Check circuit breakers in power line.
	2c. Broken wire or loose connections in interconnecting cables.	2c. Examine all interconnecting cables for broken wires and loose connections at the plug terminals.
	2d. If trouble is not located in items mentioned above, the fault is probably in either the Dynamotor Power Unit or in the transmitter unit.	2d. Replace Dynamotor Power Unit. If replacement of this unit does not correct the fault, then Transmitter Unit should be replaced and defective transmitter is to be sent to repair station.

TABLE 5-1. TROUBLE SHOOTING ON INSTALLED EQUIPMENT (Cont'd)

Faults That Prevent Operation of Entire Equipment (continued)

<i>Symptoms</i>	<i>Probable Cause of Trouble</i>	<i>Remedy</i>
<p>3. Dynamotor or red indicator lamp only operates momentarily when overload relay "RESET" buttons are pressed, and then relays open circuit again when button is released.</p>	<p>3a. Equipment is drawing excessive current due to a defective tube.</p>	<p>3a. Turn off equipment. Remove cover of transmitter and check tubes as described in paragraph 2b that follows this table.</p>
	<p>3b. Excessive current due to short circuit or defective part in Pilot's Control Unit.</p>	<p>3b. If short circuit only occurs when LOCAL REMOTE switch is in "REMOTE" position, then Pilot's Control Unit is at fault, and should be removed. NOTE: To turn equipment on when switch is in "REMOTE" position, use Control on Pilot's Control Unit. If overload relay also opens when switch is set to "LOCAL," fault is not in Pilot's Control Unit; see Cause 3c.</p>
	<p>3c. Excessive current due to short circuit or defective part in Antenna Load Unit. NOTE: This condition cannot occur if control "A" is set to a position other than 13 (L.F.). Thus, if control "A" was set to any of the other 12 positions when the short circuit occurs, disregard this cause.</p>	<p>3c. Turn off equipment. Set CALIBRATE-TUNE-OPERATE switch to TUNE position. Disconnect Plug U-11/U. Turn on equipment and press relay "RESET" buttons. Close TEST key. If short circuit is cleared fault is in Antenna Load Unit and replacement is required. If overload relay still opens it indicates that short circuit was not in the Antenna Load Unit. In that case, reconnect Plug U-11/U and check cause 3d.</p>
	<p>3d. Excessive current due to short circuit or defective part in Transmitter or Dynamotor Power Unit.</p>	<p>3d. Turn off equipment. Replace Dynamotor Power Unit. Turn on equipment. Close TEST key. If short circuit is cleared, the Dynamotor Unit, that was replaced, contained the short. If overload relay on new Dynamotor Unit still opens, the short circuit was not in the Dynamotor Unit but is in the Transmitter Unit. In that case Transmitter should be removed and sent to repair station.</p>
<p>4. No R-F power output on any frequency range. Transmitter is not radiating a signal when telegraph key or microphone switch is closed. No voice or tone is heard in headset. Antenna current is zero and P.A. GRID current is approximately zero. Red indicator light is on and dynamotor operates. IMPORTANT: CALIBRATE - TUNE - OPERATE switch must be in OPERATE position to obtain full R-F power output.</p>	<p>4a. Control "C" is set between two of the numbered positions.</p>	<p>4a. Setting of Control "C" is critical. If it is set between positions, equipment will not operate. Set carefully so that numbered position lines up with index line.</p>
	<p>4b. Fuse in 400 volt plate and screen supply circuit may have blown. Fuse is located in retainer on front of Dynamotor Power Unit. Spare fuse is provided in adjacent holder.</p>	<p>4b. Turn off equipment. Remove fuse and examine it. If fuse is O.K., replace it and see Cause 4c. If fuse is blown, check for faulty tube as described in paragraph 2b which follows the table. If fuse still blows after tubes are replaced then fault is due to short in Dynamotor Unit or Transmitter. To determine which is the cause, replace Dynamotor Unit. If fuse still blows, short is in Transmitter and that unit should be removed and sent to repair station.</p>
	<p>4c. If Antenna Shunt Capacitor is connected to the equipment and is in use, it may be short circuiting the R-F output.</p>	<p>4c. Turn off equipment. Disconnect Antenna Shunt Capacitor from transmitter by opening switch in series with it. Operate transmitter at any frequency higher than 3000 KC. If R-F output still cannot be obtained, Shunt Capacitor was not causing the trouble. See 4d.</p>
	<p>4d. Faulty tube. Those most likely to be the cause of trouble are V101, V102, V103, V104, V2601 or *V801 and *V802.</p>	<p>4d. Check tubes as described in paragraph 2b that follows this table.</p>
<p>5. Pilot's Control Unit will not turn equipment on or off but equipment can be operated on and off by using Control on the transmitter panel.</p>	<p>5a. LOCAL-REMOTE switch on transmitter is set to "LOCAL" position.</p>	<p>5a. Set LOCAL-REMOTE switch to "REMOTE" position when equipment is to be operated from Pilot's Control Unit. If transmitter still cannot be turned on at Pilot's Control Unit, see Cause 5b.</p>
	<p>5b. Loose connection at plugs U-6/U or U-8/U.</p>	<p>5b. Check connections at plugs to insure good contact. Also inspect interconnecting cable for broken wire. If fault is not found, see Cause 5c.</p>
	<p>5c. Fault is in either the Pilot's Control Unit or the Transmitter.</p>	<p>5c. Replace Pilot's Control Unit. If fault is not corrected by this replacement, then the cause of the trouble is in the transmitter and that unit should be removed and sent to repair station.</p>

TABLE 5-1. TROUBLE SHOOTING ON INSTALLED EQUIPMENT (Cont'd)

Arcing or "FLASHOVER" At High Altitude

<i>Symptoms</i>	<i>Probable Cause of Trouble</i>	<i>Remedy</i>
6. When equipment is operated at an altitude higher than 20,000 to 25,000 feet, arcing occurs. The arcing may be intermittent or continuous. Arcing may cause power supply circuits to be overloaded and overload relays on Dynamotor Power Unit will open.	6a. Pressure operated switch in Dynamotor Unit should operate to reduce high voltage from 1150 to 750 volts at altitudes higher than 20,000 to 25,000 feet. This switch may be defective.	6a. A faulty pressure operated switch can be detected by watching the action of the antenna current reading as the plane is gaining altitude. Use CW emission and hold telegraph key closed while making this observation. At some altitude between 20,000 and 25,000 feet, the pressure switch should operate and a marked reduction of antenna current should be noted. If antenna current does not change, pressure operated switch may be assumed to be defective or out of adjustment and Dynamotor Unit should be removed from plane for repairs. If a prolonged flashover occurs, it may destroy parts of the equipment. A careful "Pre-flight" inspection should be made to determine if operation has been affected.
	6b. If equipment is used at altitudes higher than 40,000 feet, arcing is likely to occur.	6b. Radio Transmitting Set AN/ART-13A equipment is not designed for use at altitudes above 40,000 feet. If a prolonged flashover occurs it may destroy parts of the equipment. A careful "Pre-flight" inspection should be made to determine if operation has been affected.
	6c. If pressure operated switch is working satisfactorily and equipment is not operated at an altitude above 40,000 feet but flashover still occurs; then the fault is probably caused by defective insulation or improper spacing between parts.	6c. Turn off equipment. Examine the unit where arcing occurred. If the exact location where the arc occurred can be readily found, look for sharp pointed projections. "Flashover" occurs more readily between projecting points in the electric wiring. If remedy cannot be easily applied, remove complete unit from plane to be sent to repair station.

No R-F Output On One Frequency Range: Operation On Other Frequency Ranges Is O.K.

7. No R-F output in low frequency range, VFO operation 200 to 600 Kc; or Crystal-controlled operation (AN/ART-13B only) in the 300 to 500 Kc range. Equipment operates satisfactorily on other frequency ranges. NOTE: If R-F output is not obtained on any frequency range, see Symptom No. 4.	7a. Control A or Control "C" is not set correctly.	7a. The setting of these controls is critical. Be sure number is exactly in line with index mark.
	7b. CALIBRATE - TUNE - OPERATE switch is not in OPERATE position.	7b. This switch must be in OPERATE position to obtain full R-F power output.
	7c. Loose connection at Plugs U-11/U and U-12/U or poor connection at load coil terminal on transmitter and terminals on Antenna Loading Unit.	7c. Turn off equipment and check for loose connections or broken leads.
	7d. Low frequency oscillator tube is faulty.	7d. The low frequency oscillator tube is a type JAN-1625 and is identified in this manual as V2601. This tube may require replacement. See paragraph 2b(3) this section for location and replacement instructions.
	7e. If above causes do not apply, then fault is either in Antenna Load Unit or in the Transmitter.	7e. Turn off equipment. Replace Antenna Load Unit. If R-F output still cannot be obtained, the fault is in the transmitter and that unit should be removed for repair.
	*7f. VFO-XTAL switch improperly set.	*7f. This switch must be set for "XTAL" operation.
	*7g. Crystals not in place.	*7g. The four low frequency channels require four crystals, one in a dual type holder.
8. No R-F output in the 6.0 Mc to 18.1 Mc frequency range, VFO operation; *or the 6.0 Mc to 18.0 Mc frequency range, Crystal-controlled operation. Equipment operates satisfactorily	8a. Control "A" or Control "C" is set between numbered positions.	8a. The setting of these controls is critical. Be sure numbered position is set exactly in line with index mark.
	8b. CALIBRATE - TUNE - OPERATE switch is not in OPERATE position.	8b. This switch must be in OPERATE position to obtain full R-F power output.
	8c. Loose connection at Antenna terminal of transmitter or terminals on Antenna Load Unit.	8c. Turn off equipment and check for loose connections or broken leads.

TABLE 5-1. TROUBLE SHOOTING ON INSTALLED EQUIPMENT (Cont'd)

No R-F Output On One Frequency Range: Operation On Other Frequency Ranges Is O.K.

<i>Symptoms</i>	<i>Probable Cause of Trouble</i>	<i>Remedy</i>
on low frequency range. NOTE: If R-F output is not obtained on any frequency range, see Symptom No. 4.	8d. Tubes V101, V102, V103, or V104 may be faulty.	8d. Obtain access to and check these tubes as described in paragraph 2b following this table.
	8e. If above causes do not apply, then fault is either in Antenna Load Unit or in transmitter.	8e. Turn off equipment. Connect antenna lead-in directly to ANT. post on transmitter. If R-F output can now be obtained, Load Unit was at fault and replacement is required. If R-F output still cannot be obtained, the fault is in the transmitter and that unit should be removed for repair.
	*8f. VFO-XTAL switch improperly set.	*8f. This switch must be set for "XTAL" operation, or "VFO" operation, whichever is desired.
	*8g. V801 tube may be faulty.	*8g. Check this tube as described in paragraph 2b following this table.
9. No R-F output in the 2.0 Mc to 6.0 Mc frequency range, VFO operation; *or the 1.67 Mc to 6.0 Mc frequency range, crystal-controlled operation. Equipment operates satisfactorily on low frequency range. NOTE: If R-F output is not obtained on any frequency range, see Symptom No. 4.	*8h. Crystals not in place.	*8h. A separate crystal is required for each output frequency desired.
	9a. See causes 8a, 8b, and 8c.	9a. Use remedies 8a, 8b, and 8c.
	9b. Tubes V101, V102 or V104 may be faulty.	9b. Obtain access to and check these tubes as described in paragraph "B" following this table.
	9c. If above causes do not apply then fault is either in Antenna Load Unit or in transmitter.	9c. Turn off equipment. Connect Antenna lead-in directly to ANT. post on transmitter. If R-F output can now be obtained, Load Unit was at fault and replacement is required. If R-F output still cannot be obtained, the fault is in the transmitter, and that unit should be removed for repair.
	9d. See causes 8f, 8g and 8h.	9d. Use remedies 8f, 8g and 8h.

R-F Output Is Not Tone Modulated When MCW Emission Is Used

10. Output is not tone modulated and the emission is the same as that obtained for CW operation. In addition, sidetone will not be heard in the headphones. NOTE: Check operation when VOICE emission is used. If VOICE modulation has also failed, refer to Symptom No. 11.	10a. MCW oscillator tube V2203 may be faulty.	10a. Obtain access to and check this tube as described in paragraph "B" following this table.
	10b. Failure of a part in the MCW oscillator circuit.	10b. Remove transmitter unit to repair station for further analysis. NOTE: If desired the small sub-assembly that contains the MCW oscillator may be replaced without removing the transmitter. This small chassis containing one JAN-12SA7 and two JAN-12SL7GT tubes is easily accessible from top of transmitter (see fig. 5-6). It is held in place by a screw at each side, going through the top. Since all connections are made by means of a plug, the chassis is disconnected by lifting straight up.

R-F Output Is Not Voice Modulated When Voice Emission Is Used

11. Output is not received on associated receiving set. Also, no voice modulation is heard in the headphones connected to transmitter sidetone jacks. NOTE: If	11a. Microphone plug is loosely plugged in, making poor connection.	11a. Be sure microphone plug is pushed in as far as it will go.
	11b. Carbon microphone is being used and microphone switch S201 (located behind chart panel on transmitter, see fig. 2-2) is in "DYNAMIC" position.	11b. Set microphone switch to "CARBON" position.

TABLE 5-1. TROUBLE SHOOTING ON INSTALLED EQUIPMENT (Cont'd)

R-F Output Is Not Voice Modulated When Voice Emission Is Used (continued)

<i>Symptoms</i>	<i>Probable Cause of Trouble</i>	<i>Remedy</i>
satisfactory VOICE output is obtained in the headphones connected to sidetone jack of transmitter, disregard items a, b, c, and d in next column and proceed with e.	11c. Dynamic microphone is being used and microphone switch is in "CARBON" position.	11c. Set microphone switch to "DYNAMIC" position.
	11d. If no VOICE output is heard in headphones, one or more of the following tubes may be faulty: V201, V202, or V203.	11d. Obtain access to and check tubes as described in paragraph 2b following this table. If replacement of these tubes does not correct the trouble, the transmitter unit should be removed and sent to repair station.
	11e. If VOICE output is heard in headphones but R-F output is not VOICE modulated, then tubes V105 and V106 may be faulty.	11e. Obtain access to and check tubes as described in paragraph 2b following this table. If replacement of these tubes does not correct the trouble, the transmitter unit should be removed and sent to repair station.

No Voice or Sidetone Heard In Headphones But R-F Output Is Modulated.

12. No signal is heard in headphones connected to sidetone jack on transmitter, but equipment is operating satisfactorily in all other respects. NOTE: If R-F output is not obtained, see Symptom No. 4.	12a. Headphone plug is loosely plugged in, making poor connection.	12a. Be sure headphone plug is pushed in as far as it will go, in, making poor connection.
	12b. The volume of the signal heard in headphones is controlled by "OUTPUT" switch located behind chart on transmitter (see fig. 2-2). Volume level of output may be set too low.	12b. To increase volume, turn OUTPUT switch toward higher numbered positions.
	12c. Sidetone Amplifier tube V203 may be faulty.	12c. Obtain access to and check tube as described in paragraph 2b following this table. If replacement of this tube does not correct the trouble the transmitter unit should be removed and sent to repair station. NOTE: If desired, the small sub-assembly that contains the Sidetone Amplifier may be replaced without removing the transmitter. This small chassis containing one JAN-12SJ7 and two JAN-6V6GT tubes is easily accessible from top of transmitter (see fig. 5-6). It is held in place by a screw at each side, going through the top. Since all connections are made by means of a plug, the chassis is disconnected by lifting straight up.

Low R-F Output

13. Low R-F output will be indicated by the values of the following meter readings: P. A. GRID and P. A. PLATE. When checking for low R-F output, set EMIS- SION switch to CW position and select a transmission frequency above 3000 Kc.	13a. If plane is gaining altitude when power output suddenly decreased, the reduction may be due to the normal action of a pressure operated switch in the power supply system.	13a. The pressure operated switch operates at altitudes between 20,000 and 25,000 feet to reduce high voltages at high altitudes and prevent "flashover." The reduced voltage on the power amplifier stage causes approximately 1/2 reduction of R-F power output.
	13b. Power level switch (CALIBRATE-TUNE-OPERATE) may be in TUNE position.	13b. Power level switch must be in OPERATE position for maximum R-F power output.
	13c. Antenna tuning and loading controls "C," "D," and "E" may not be set properly.	13c. See instructions starting with paragraph 6b(4)(o) section II, for adjusting these controls to properly tune and load the antenna system. These instructions are also given in the Calibration Book.
	13d. If using VFO operation, and the following condition cannot be obtained, power amplifier tube V104 may be defective or multiplier tubes V102	13d. If P.A. PLATE and P.A. GRID readings are low, the V104 tube is probably the cause. Obtain access to and check tube as described in paragraph 2b following this table.

TABLE 5-1. TROUBLE SHOOTING ON INSTALLED EQUIPMENT (Cont'd)

Low R-F Output (continued)

<i>Symptoms</i>	<i>Probable Cause of Trouble</i>	<i>Remedy</i>
	and V103 may be defective; P.A. PLATE meter readings should rise to at least 150 divisions when Control "D" is detuned from its correct (resonant) setting, provided that the P.A. GRID reading is between 40 and 140 divisions.	If P.A. PLATE reading is above 150 and P.A. GRID is below 40, then tube V102 or V103 is probably the cause. Obtain access to and check tubes as described in paragraph 2b following this table. If P.A. PLATE reading is above 200, and P.A. GRID reading is <i>not</i> less than 40, then power amplifier tube V104 is "soft" or "gassy" and should be replaced. If replacement of tubes does not increase power output the transmitter unit should be removed and sent to repair station.
*13e. Low crystal activity.		*13e. With low activity, P.A. GRID meter reading will be excessively low. Replace crystal and check for increase in P.A. GRID reading. This reading should never go below 40 for the high frequency band. It will be lower for the low frequency band, but minimum cannot be given as it will depend on the frequency and the antenna characteristics.
	*13f. Faulty oscillator tubes, V801 or V802.	*13f. Obtain access to and check tubes, as described in paragraph 2b following this table.

Excessive Distortion Occurs When Voice Emission is Used

14. VOICE is considerably distorted when heard on headphones that are connected to a Radio Receiving Set.	14a. If VOICE is also distorted when headset is connected to Sidetone jack on transmitter, the fault is probably in the speech amplifier section of the transmitter. 14b. If voice is not distorted when heard in headphones connected to sidetone jack on transmitter, the distortion, in transmitter output, may be caused by tubes V104, V105, and V106.	14a. Obtain access to and check tubes V201, V202, and V203 as described in paragraph 2b following this table. If distortion is not eliminated by replacing tubes, the fault is in the transmitter and that unit should be removed and sent to repair station. 14b. Obtain access to and check tubes V104, V105, and V106 as described in paragraph 2b following this table. If distortion is still excessive after tubes are replaced, transmitter unit should be removed and sent to repair station.
---	--	--

"Beat Note" Cannot Be Obtained When Calibrating Low or High Frequency Oscillators

15. High or Low frequency Oscillator Controls are set to any "check point" (settings shown in heavy black type) in the calibration tables. A "beat note" is not heard in the headphones and it is impossible to "zero beat" or check the calibration of either High or Low Frequency Oscillator. NOTE: It is assumed here that when transmitter is operated, R-F output is satisfactory and VOICE or keyed signal can be heard in headphones connected to	15a. CALIBRATE - TUNE - OPERATE switch is not in CALIBRATE position. 15b. Defective Crystal in the Calibration Oscillator Unit. 15c. Tubes V2201, V2202, or V2203 may be faulty. 15d. Defective part or loose connection in the transmitter. It is probable that the fault is located in the MCW-CFI unit chassis (see fig. 5-6). This small chassis can be removed for replacement if desired. It is held in place by two screws that pass through the top of the chassis on each side.	15a. This switch must be in the "CALIBRATE" position, otherwise the calibration oscillator will not operate. 15b. Turn off equipment. Remove cover of transmitter and replace Crystal. See figure 8-8 for location of the crystal which is designated by the symbol Y2201. 15c. Obtain access to and check these tubes as described in paragraph 2b following this table. 15d. If the above items have been checked and the calibrating "beat note" still cannot be obtained, the transmitter unit should be removed and sent to repair station.
---	---	---

TABLE 5-1. TROUBLE SHOOTING ON INSTALLED EQUIPMENT (Cont'd)

"Beat Note" Cannot Be Obtained When Calibrating Low or High Frequency Oscillators

<i>Symptoms</i>	<i>Probable Cause of Trouble</i>	<i>Remedy</i>
sidetone jack. If R-F output is not obtained see Symptom No. 4. If sidetone or voice is not heard see Symptom No. 12.		

"Autotune" System Will Not Operate

16. When CHANNEL Selector switch is set to one of the 11 channels the automatic tuning mechanism will not operate to change the transmission frequency. NOTE: If red indicator lamp on transmitter does not light when LOCAL - REMOTE switch is in "LOCAL" position, then Autotune mechanism is probably O.K. but there is a fault in the power supply; see Symptom No. 1.	16a. LOCAL - REMOTE switch is in wrong position. 16b. Telegraph key, throttle switch, microphone switch, or test switch is closed. 16c. Overload relay on Dynamotor Power Unit has opened. 16d. If Autotune still will not operate the fault is probably in the mechanism or associated electrical Controls.	16a. This switch must be set to "LOCAL" when using controls on transmitter. If Pilot's Control Unit is used, set switch to "REMOTE". 16b. The Autotune mechanism will not operate when the transmitter is being keyed. Key must be open when Autotune operates to change frequency. 16c. Press RESET button labeled "TRANS. RESET." 16d. Remove transmitter unit and send to repair station.
--	---	---

Autotune Does Not Return Controls To Correct Settings

17. Autotune mechanism operates but does not return the controls correctly to the positions for which it was originally set.	17a. Autotune was not set up properly. When knobs were adjusted to final settings they were rotated in a counterclockwise direction. 17b. If autotune motor runs continuously (more than 30 seconds) and does not stop, there is a fault in the electrical system of the mechanism. If Autotune mechanism has returned some of the control knobs to their correct settings but other knobs are set incorrectly, the trouble may be due to a broken spring in the mechanism or improper synchronization of all of the units.	17a. When a control knob is being set to a desired position, YOU MUST ALWAYS TURN THE KNOB CLOCKWISE WHEN APPROACHING THE SETTING. If you accidentally rotate the knob past the setting, turn it back a half turn and again approach final setting by turning clockwise. 17b. Transmitter unit should be removed and sent to repair station. 17c. Be sure that all control knobs were correctly set up originally by approaching final dial setting in CLOCKWISE direction, <i>not counterclockwise</i> . If Autotune still does not operate properly after rechecking the set-up, remove the transmitter unit and send to repair station.
--	---	--

Autotune Motor Runs Continuously—Will Not Turn Off

18. Autotune motor can be heard running continuously, even after control knobs stop at final settings.	18a. Fault in electrical system of the Autotune mechanism.	18a. Remove transmitter unit and send to repair station.
--	--	--

b. TUBE CHECKING AND REPLACEMENT.

WARNING

Be sure to turn off the entire equipment before attempting to remove cover of transmitter and replace tubes. This equipment utilizes high voltages which are dangerous to life. Operating personnel must observe all safety regulations.

(1) All of the tubes used in this equipment are located in Radio Transmitter T-47A/ART-13 (AN/ART-13A) or Radio Transmitter T-412/ART-13B (AN/ART-13B), and are easily accessible when the top of that unit is removed. Before removing this cover, be sure to turn off entire equipment by setting LOCAL-REMOTE switch to "LOCAL" position and the EMISSION switch (on transmitter panel) to "OFF". Also, make certain that the KEY, MICROPHONE and THROTTLE switches are open.

(2) REMOVING TOP COVER OF TRANSMITTER.—One hold-down screw is used at each side of the top cover. To remove the cover, insert a coin or screw driver in each screw and make a half turn counterclockwise. The cover can now be lifted off.

(3) LOCATING TUBES.—The position of each of the tubes used in this equipment is shown in the following illustration. All tubes, with exception of V2601 (Low Frequency Oscillator), are visible and readily accessible when transmitter cover is removed. The Low Frequency Oscillator tube V2601 can be reached by removing the cover of the Low Frequency Oscillator Unit. This unit is located directly behind control "G" and the cover contains numerous ventilation holes. To remove cover, take out screws around the rim of the cover.

(4) REMOVING TUBES.—Tube clamps are used on some of the tubes in this equipment to prevent the tube from coming out of the socket under vibration incident to normal service. The operation of the tube clamp is shown in the insert sketch on figure 5-1. To open clamp, insert screw driver as shown and gently pry open. The clamps on tubes V105 and V106 are accessible through the rear cover plate. Clamps on tubes V102 and V103 can best be reached from top of transmitter. Obtain access to clamp on V101 through side cover plate.

(a) To replace tube V104 (which is a type JAN-813), orient the base pin with the slot in hole

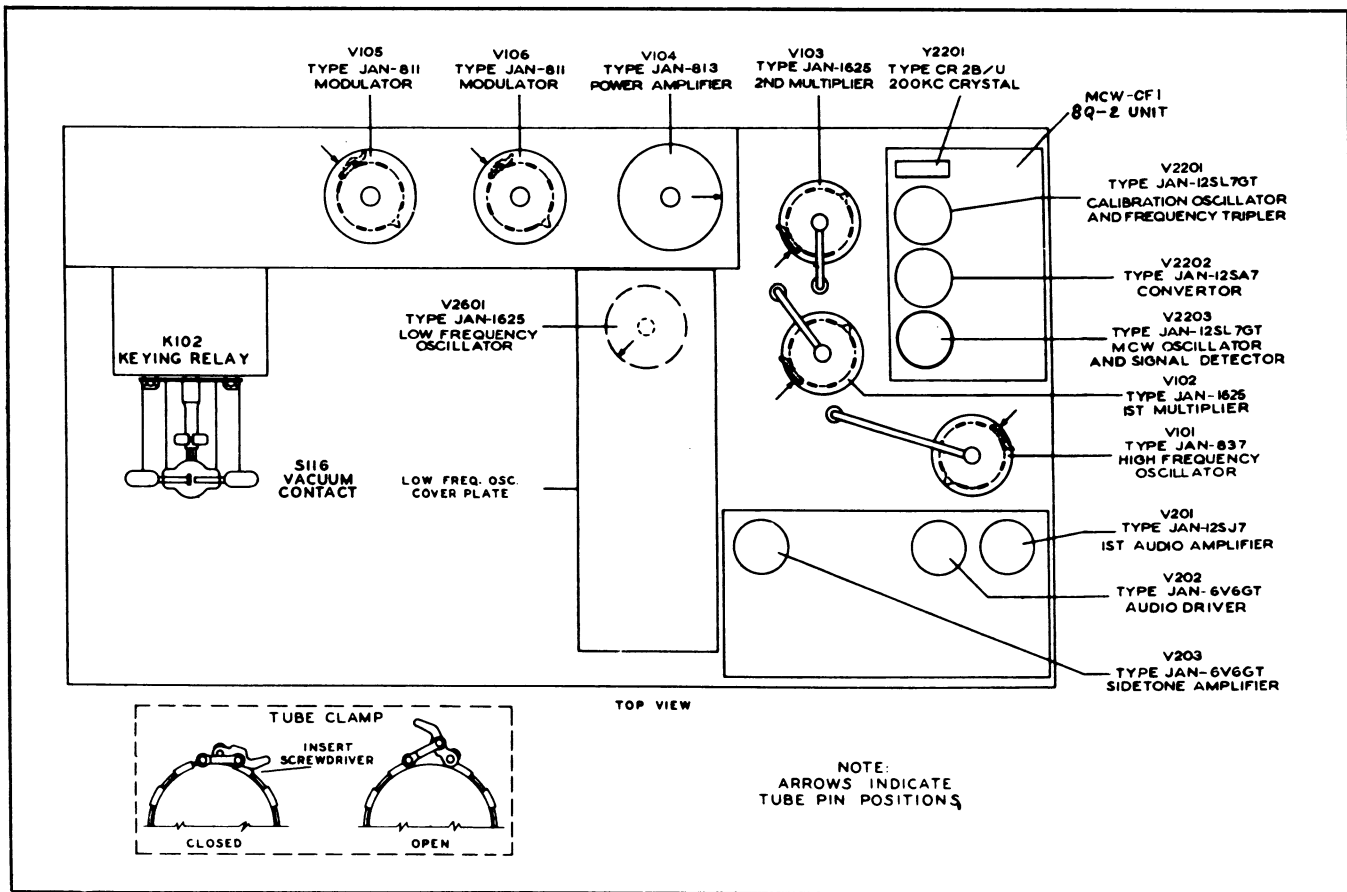

Figure 5-1. Tube Placement Diagram AN/ART-13A

above socket and then press down firmly until tube pins are solidly engaged in the socket.

(5) CHECKING TUBES.—Whenever tube failure is suspected, the most dependable method of checking the tube is to replace it with another tube known to be in good condition. To quickly determine which tubes require checking refer to table 5-2. If one or more of several tubes are the cause of faulty operation, each tube should be replaced and the new tube should remain in the equipment until all tubes have been replaced or until the faulty tube has been located.

3. TROUBLE SHOOTING AT REPAIR STATION.

The information and instructions given in the following paragraphs should only be used after the fault has been traced to one of the major units (Transmitter, Control Unit, Dynamotor, or Loading Unit) by using the simplified trouble-shooting procedure given in paragraph 2 and table 5-1, this section.

a. TROUBLE-SHOOTING TABLE.—When trying to find the exact location of a fault, it is desirable to first make a preliminary examination and determine approximately which portion or circuit of the equipment is affected. The following table is designed to assist in locating the circuit or major sub-assembly that contains the fault. Any tests, measurements, or observations that are recommended can be accomplished without major disassembly of the unit. After the offending circuit or subassembly has been located, it is necessary to know how to obtain access to or how to remove that item. This information is given in paragraphs of this section, starting with paragraph 3.b.

(1) When using the following trouble-shooting table, it is understood that the faulty major unit has been connected into a mock-up at the repair station and that other major units and interconnecting cables

in the mock-up are to be in perfect condition. It is also assumed that all tubes in the faulty unit have been checked by replacement.

(2) A set of Phillips screw drivers and Allen set-screw wrenches are supplied with each equipment and are mounted in special clips on the inside of the transmitter cover. In addition to these tools, the ordinary tools such as common screw drivers, pliers, and soldering iron will be required to remove or replace parts.

(3) A volt-ohmmeter will be required to measure operating voltages and to make continuity or resistance measurements. The instrument should be capable of measuring d-c voltages up to 1500 volts and should have an internal resistance of 20,000 ohms per volt (instruments with internal resistances of 1000 or 5000 ohms per volt may also be used, but readings will be correspondingly lower than the values shown in tables 5-1 through 5-4 in this manual, since these tables were prepared by using a 20,000 ohm per volt instrument). Use of a vacuum-tube-voltmeter is recommended when measuring voltages in grid circuits.

(4) High voltage circuits should not be checked with a voltmeter unless other means cannot be used. This practice is advocated in the interest of safety.

WARNING

When cover of transmitter is removed be sure to turn off power. High voltages (1150 volts) appear at plate connection caps on top of tubes. Avoid checking for loose connections or poor contacts while power is on. Check continuity of suspicious connection by using an ohmmeter.

CAUTION

No transmissions will be made on emergency (distress) H.F. Channels except for emergency purposes. For testing, demonstration or drill purposes, radio equipment will be operated into a non-radiating dummy load instead of an Antenna to prevent transmission of false distress signals.

TABLE 5-2. TROUBLE SHOOTING AT REPAIR STATION

Faults In Transmitter Unit

<i>Symptoms</i>	<i>Probable Cause of Trouble</i>	<i>Remedy</i>
<i>Transmitter Will Not Turn On</i>		
1. Red indicator lamp is off; dynamotor will not operate when EMISSION switch is in CW or MCW position and Autotune mechanism does not operate when CHANNEL switch is operated.	1a. Lamp may be burned out. Check lamp and then see 1b.	1a. Replace lamp. Red window in front of lamp is removed by pulling forward on knurled ring that surrounds it. Lamp has bayonet base and is removed by pushing in and turning counterclockwise.
	1b. Poor contact on EMISSION switch S110 or on LOCAL-REMOTE switch S107.	1b. Check continuity of contacts on both switches. See simplified circuit, figure 4-2. See figure 8-2 for switch location.
	1c. Poor contact at plug U-7/U or receptacle J108.	1c. Check for loose connection at plug and receptacle.
2. Dynamotor does not operate when VOICE emission is used.	2a. If emission switch is in VOICE position dynamotor will only operate when microphone switch is closed. Microphone switch may be defective.	2a. Press microphone switch. If dynamotor does not run, close TEST switch. If dynamotor runs with TEST switch closed then poor connection at microphone switch or plug is causing trouble.
	2b. Contacts No. 1 and No. 2 of VOICE relay K104 are not closed. See figure 8-42 for contact numbers. See simplified circuit figure 4-2.	2b. K104 is located at bottom of transmitter (see fig. 8-3). Remove bottom cover plate and check relay action and contacts. See circuit in figure 4-2. Check contacts of EMISSION switch S110.
	2c. Rear limit switch S111 on Autotune mechanism is open or contacts No. 1 and No. 3 of autotune motor control relay K101 are not closed. See figure 8-42 for contact numbers.	2c. See figures 4-2 and 4-20. Remove panel around bottom row of controls (see fig. 8-1). See figure 8-3 for location of K101 and S111. Check contacts. Check action of relay when autotune mechanism is operated.
3. Dynamotor does not operate when CW emission is used.	3a. Contacts No. 4 and No. 5 of CW relay K103 may not be closing; see figure 8-42 for relay contact numbers.	3a. K103 is located at bottom of transmitter (see fig. 8-3). Remove bottom cover plate and check relay action and contacts. See circuit in figure 4-2. Check contacts of EMISSION Switch S110 and LOCAL-REMOTE Switch S107.
	3b. See 2c.	3b. See 2c.
4. Dynamotor does not operate when MCW emission is used.	4a. Poor contact on EMISSION switch S110 or LOCAL-REMOTE switch S107.	4a. Check continuity of both switches. See simplified circuit figure 4-2. See figure 8-2 for switch location.
	4b. See 2c.	4b. See 2c.
5. Autotune mechanism will not operate. Dynamotor operates and rest of equipment is O.K.	5a. LOCAL-REMOTE switch must be in local position when using CHANNEL switch on transmitter.	5a. Set switch to LOCAL position.
	5b. Telegraph key, throttle switch, microphone switch or test key are closed.	5b. Autotune will not operate when transmitter is being keyed.
	5c. CALIBRATE - TUNE - OPERATE switch is in CALIBRATE position.	5c. Autotune mechanism will not operate when this switch is in CALIBRATE position. Set switch to OPERATE or TUNE positions as desired.
	5d. Poor contact at CHANNEL selector switch S108 or Autotune circuit seeking switch S109.	5d. See circuit in figure 4-20. Remove panel around bottom row of controls (see fig. 8-1). See figure 8-3 for location of S109 and figure 8-2 for location of S108. Check contacts.
	5e. Poor contacts on Autotune Motor Control Relay K101 or on Autotune rear limit switch S111.	5e. See circuit in figure 4-20. Remove panel around bottom row of controls (see fig. 8-1). See figure 8-3 for location of K101 and S111. Check contacts.

TABLE 5-2. TROUBLE SHOOTING AT REPAIR STATION (Cont'd)

Faults In Transmitter Unit (Cont'd)

<i>Symptoms</i>	<i>Probable Cause of Trouble</i>	<i>Remedy</i>
<i>Transmitter Will Not Turn On (continued)</i>		
	5f. Contacts No. 2 and No. 12 of Keying Relay K102 are not closed. (Numbers refer to plug on side of relay case).	5f. These contacts must close when Relay is at rest or unoperated position. (See circuits in figs. 8-42 and 4-20.)
	5g. Defective Autotune Motor B101.	5g. Check continuity of Autotune Motor Windings. See motor circuit in upper left corner of figure 8-42.
6. Tube filaments do not light. Dynamotor operates. Red indicator light is on. Autotune operates.	6a. Poor contact or broken wire at plug U-7/U or receptacle J108.	6a. Check for loose connection at plug or receptacle.
	6b. Loose connection at socket of tube or a defective tube.	6b. See filament circuits in figure 4-3. Check for loose connection. Check tubes by replacement.
7. No R-F output. Red indicator is on, dynamotor operates, and Autotune mechanism operates.	7a. See Symptom No. 10.	7a. See Remedy No. 10.
8. Dynamotor overload relay opens. Relay will not stay closed after DYNA. RESET button is pushed; or fuse blows.	8a. Short in high voltage circuits of transmitter. Look for burnt, overheated, or smoking part.	8a. Disconnect plug U-7/U and refer to table 5-4 in this section. Measure resistance from J108 pins Nos. 1, 2, 9, and 10 to ground. If resistance is appreciably lower than value shown in table, a short is indicated. If short is on pin No. 1, see 8b. If short is on No. 2 or No. 9 see 8c. If short is on pin 10, see 8d.
	8b. Short from pin No. 1 of J108 to ground. (This is 400 volt Supply). Causes fuse on dynamotor to blow. May be caused by short at following points in transmitter: (a) Power Amplifier Stage (b) L.F. Oscillator Unit (c) H.F. Oscillator Unit (d) Multiplier Unit (e) Audio Amplifier Unit (f) MCW-CFI Unit	8b. Trace circuit containing short by measuring resistance from tube terminals to ground for tubes in each of these stages. See Resistances in table 5-5.
	8c. Short from pins No. 2 or No. 9 of J108 to ground. This is circuit to meter reading P.A. PLATE current. Possible short in wiring to meter or at meter selector switch S105.	8c. Check for shorts around meter M102 and switch S105. Both are located on meter panel at front of transmitter.
	8d. Short from pin No. 10 of J108 to ground. Caused by possible short in wiring and components associated with power amplifier (V104) plate circuit or Modulator (V105 and V106) plate circuits.	8d. Check for shorts by measuring resistance to ground from tube terminals (see table 5-5).
9. Transmitter overload relay (On dynamotor unit) opens. Relay will not stay closed after TRANS. RESET button is pushed.	9a. Short circuits in a relay armature winding, Autotune electrical circuit, or connecting wiring.	9a. If short only occurs when EMISSION switch is on CW, fault is probably in CW relay K103 associated wiring or EMISSION switch. If short only occurs when EMISSION switch is on VOICE, fault is probably in VOICE relay K104, associated wiring or EMISSION switch. If short only occurs when TEST SWITCH or telegraph key is closed, fault is probably in KEYING relay K102 or associated wiring. If short occurs only when control A is in position 13 (L.F.), fault is probably in Output Circuit Selecting Relay K105, associated wiring or switch S114. (See figure 8-7 for location of S114 and figure 8-13 for location of K105.)

TABLE 5-2. TROUBLE SHOOTING AT REPAIR STATION (Cont'd)

Faults In Transmitter Unit (Cont'd)

<i>Symptoms</i>	<i>Probable Cause of Trouble</i>	<i>Remedy</i>
<i>Transmitter Will Not Turn On (continued)</i>		
		Check Autotune electrical circuit (fig. 4-20) for shorts or mechanical binding that would stall motor (use autotune line shaft crank, supplied in spares, to see if shaft turns freely. See figure 8-6 to attach crank).
9b. Short circuit in tube filament wiring. Look for burnt or smoking part.	9b. See tube filament circuit in figure 4-3. Remove all tubes and check wiring for shorts. Use table 5-3 in this section.	
9c. Short circuit in Autotune motor or associated switches and wiring.	9c. See figure 4-20 for autotune electrical system. Check motor switches and wiring for shorts.	
<i>No R-F Output On Any Frequency Range — VFO or XTAL Operation</i>		
10. No R-F output on any frequency. Dynamotor operates; there is no overload; and Autotune mechanism operates O.K. CALIBRATE-TUNE-OPERATE switch is in OPERATE position. IMPORTANT: —Be sure Control "C" is set so that numbered position lines up exactly with index line. R-F output will not be obtained if this control is set between numbered positions.	10a. Note whether Keying Relay (K102) operates when TEST key is closed. If it does not, fault is in 28 volt supply circuits to this relay. See figure 4-2. Note whether vacuum contact (S116) has a broken or cracked bulb. If continuous arcing occurs, glass bulb or seal of vacuum contact have been destroyed (see replacement procedure in paragraph 8 of this section).	10a. Check contacts S113D of Multi-Element Switch (see fig. 8-16). These contacts must be closed when control "C" is set to any numbered position. Check for closed contacts on Rear Limit Switch S111 (on Autotune Unit at side of Control "B"), and if contacts No. 1 and No. 3 on Motor Control Relay K101 (see fig. 8-42) are closed. Check armature winding of Keying Relay K102 for continuity. (Armature is connected to plug terminals No. 14 and No. 15 of this relay.)
	10b. If P.A. GRID meter reading is normal and P.A. PLATE reading is much higher than normal, fault is in output network. Examine Vacuum Switch contact (S116). See figure 8-2 for location of this switch.	10b. Turn off equipment and check output network parts for shorted capacitors or poor contacts at Multi-Element Switch S113 and at Output Relay K105. If shunt capacitor unit is in use, check it for a short by replacing it with a unit that is known to be good. Be sure vacuum contact (S116) operates properly and that contacts are O.K.
	10c. If P.A. GRID meter reading is normal, but P.A. PLATE reading is zero or very low, the fault is in the plate or screen supply circuits of the Power Amplifier Tube V104 or is caused by having Control "C" set between numbered positions.	10c. Check continuity of screen and plate supply circuits (see fig. 8-42) of V104. CAUTION: 1150 volts on plate and 400 volts on screen of this tube. Check for blown fuse in dynamotor.
	10d. In Model AN/ART-13A, if P.A. GRID meter reading is very low or zero, fault is in Multiplier stages or Oscillators (High or Low frequency).	10d. Check voltages at tube terminals of following tubes: V103, V102, V101, and V2601. (See voltages in table 5-1 in this section.) Check resistance from tube terminals to ground using table 5-3 in this section. Check for poor contacts at switches S103, S102, S115, S114, and S2601, S101 and plug contacts No. 3 and No. 9 of keying relay K102 (contacts of relay should connect these terminals when relay is in operated position).
	10e. In Model AN/ART-13B, low or zero P.A. GRID meter readings may result from several causes, depending on whether the equipment is operated VFO or crystal-controlled.	10e. For VFO operation, first check as outlined in 10d. VFO-XTAL switching is accomplished with relay K106, which is in the XTAL position when energized. Check the contacts to be sure they do not stick. The "VFO-XTAL" switch must be in the proper position for the type of operation desired. For XTAL operation, weak crystals may result in sufficient P.A. GRID meter reading. Check by inserting another crystal of the same frequency. Faulty oscillator tubes (V801 or V802) may also cause low readings.

TABLE 5-2. TROUBLE SHOOTING AT REPAIR STATION (Cont'd)

Faults In Transmitter Unit (Cont'd)

<i>Symptoms</i>	<i>Probable Cause of Trouble</i>	<i>Remedy</i>
<i>No R-F Output On Low Frequency Range — VFO or XTAL Operation</i>		
11. No R-F output in low frequency range (200 to 600 Kc in Model AN/ART-13A, 300 to 500 Kc in Model AN/ART-13B). Output is O.K. on other frequency ranges.	11a. Control "A" is not set exactly to position 13 (L.F.).	11a. The setting of this control is critical. Be sure No. 13 is exactly in line with index mark.
	11b. 28 volt supply for operation of relay K2501 (in loading unit) is open in the transmitter.	11b. Check voltage on pin 3 of receptacle J107 at transmitter (should be 28 volts). If no voltage is found, check contacts on relay K105 and switch S114.
	11c. Fault in VFO Low Frequency Oscillator or in wiring connecting it to grid of Power Amplifier Tube V104.	11c. Refer to figure 4-11. Check voltages on terminals of tube V2601 using table 5-1 in this section. Check resistance from tube terminals to ground using table 5-3 in this section. Check switch contacts on S2601 and S103.
	*11d. Fault in CDA-T Crystal Oscillator.	*11d. Oscillator tube, V802, may be faulty. Check and replace if necessary. Check operation of VFO/XTAL switching relay, K106. This relay must be energized to permit cathode functioning of the V802 oscillator tube. Bad or weak crystals. Replace with new crystal and check P.A. GRID meter reading for increased reading. Make a resistance check from terminals of V802 to ground, using table 5-5A.
<i>No R-F Output On High Frequency Range — VFO Operation</i>		
12. No R-F output in 6.0 Mc to 18.1 Mc high frequency range. Output is O.K. on 2.0 Mc to 6.0 Mc range.	12a. Fault in Multiplier Unit or High Frequency Oscillator Unit.	12a. Check voltages on terminals of tubes V101, V102 and V103 using table 5-1 in this section. Check contacts on switches S114, S101, S102, and S103. Refer to simplified circuit shown in figure 4-12. Check resistance from tube terminals to ground using table 5-3 in this section.
<i>No R-F Output On High Frequency Range — XTAL Operation</i>		
*13 No R-F output in 1.67 Mc to 18.0 Mc high frequency range. Output is O.K. on low frequency range, 300 to 500 Kc.	13a. See causes 10a, 10b and 10c.	13a. Use remedies 10a, 10b and 10c.
	13b. Faulty crystal on one or more channels.	13b. Low P.A. GRID meter readings are often caused by a crystal with low activity. Replacement of the crystal will correct this difficulty.
	13c. Faulty oscillator tube V801.	13c. Replace tube.
	13d. Faulty VFO/XTAL switching relay K106.	13d. This relay controls the cathode operation of V801. The relay must be energized and the contacts functioning properly to permit operation of the oscillator tube, V801.
	13e. Faulty channel switch relays on one or more channels, K801 through K810.	13e. These relays, located in the CDA-T unit, switch the crystals in and out of the oscillator circuit. Failure of any one relay affects two channel frequencies, "A" and "B".
	13f. Faulty A-B switch (S801) or A-B relay (K811).	13f. This switch and relay controls the use of either the "A" group or "B" group of crystals in the oscillator circuit. Failure of either the switch or relay will permit only one set of 10 crystals to be used. When un-energized, the relay is switched to the "A" group.

TABLE 5-2. TROUBLE SHOOTING AT REPAIR STATION (Cont'd)

Faults In Transmitter Unit (Cont'd)

<i>Symptoms</i>	<i>Probable Cause of Trouble</i>	<i>Remedy</i>
<i>R-F Output Is Not Tone Modulated When MCW Emission Is Used</i>		
14. Output is not tone modulated. VOICE emission is satisfactory. NOTE: If VOICE emission was not modulated, see Symptom No. 15.	14a. Loose plug connection to MCW-CFI Unit Chassis. 14b. Fault at contacts of VOICE relay K104, or contacts of Calibrate-Tune-Operate Switch S106. 14c. Fault in MCW Oscillator circuit.	14a. Remove MCW-CFI Unit Chassis and check plug connection that is located on the bottom (see fig. 8-9). 14b. Check for continuity across contacts 5 and 6 of VOICE relay K104 (contacts should be closed, see figs. 4-9 and 8-42). 14c. Remove MCW-CFI unit (use procedure described in paragraph 3b(4)(e), this section). Make up an extension cable and plug so that unit can be connected to plug in transmitter. Measure voltages on terminals of tube V2203 using table 5-1 in this section. Check resistance from tube terminals to ground using table 5-3 in this section.
<i>R-F Output Is Not Voice Modulated On Voice Emission</i>		
15. Output is not voice modulated.	15a. If voice is heard through sidetone output jack, fault is in Audio Driver or Modulator stages. 15b. If voice is not heard through sidetone output jack, fault is in Speech Amplifier circuits of the Audio Amplifier Unit. Be sure microphone switch is in correct position for type of microphone that is used (CARBON or DYNAMIC). If switch is set to DYNAMIC, and carbon microphone is used, no output will be obtained.	15a. Check for presence of audible signal in plate circuit of Audio Driver Tube V202, and grid circuits of both Modulator Tubes V105 and V106. (See figs. 4-6 and 4-7.) WARNING: Plates of modulator tubes operate at 1150 volts. Turn off power and check continuity of windings and transformer T101. Check connections from T101 to plate and screen of V104 (see fig. 8-42). The following contact positions should be found on CW relay K103 (see fig. 8-42): 6 and 7 are open. 7 and 8 are closed. 2 and 3 are closed. 15b. Check for loose plug connection under Audio Amplifier Unit (see fig. 8-11). Remove Unit from transmitter (use procedure described in paragraph 3b(4)(d), this section). Make up extension cable and plug so that unit can be connected to plug in transmitter. Measure voltages on terminals of tubes V201, V202, and V203 using table 5-1 in this section. Check resistance from tube terminals to ground using table 5-3 in this section.
<i>No Sidetone In Headphones—R-F Output Is O.K.</i>		
16. Signal is not heard in headset connected to sidetone jack. Equipment operates satisfactorily on VOICE emission.	16a. Check setting of "OUTPUT" switch (located behind chart panel—see fig. 2-2). 16b. Fault is in sidetone Amplifier circuit. This circuit is in Audio Amplifier Unit Chassis. 16c. Failure of contacts in Keying Relay K102. Contacts No. 6 and No. 8 on plug at side of relay case should be connected when relay is in operated position.	16a. To increase volume of output, turn switch to higher numbered position. 16b. Remove Audio Amplifier Unit from transmitter (use procedure in paragraph 3b(4)(d), this section). Make up extension cable and plug so that unit can be connected to plug in transmitter. Measure voltages on terminals of tubes V202 and V203 using table 5-1 in this section. Check resistance from tube terminals to ground using table 5-3 in this section. 16c. If contacts 6 and 8 are open, the audio signal cannot reach the sidetone jack (see circuit in fig. 4-8). Contacts should close when keying relay operates.

TABLE 5-2. TROUBLE SHOOTING AT REPAIR STATION (Cont'd)

Faults In Transmitter Unit (Cont'a)

<i>Symptoms</i>	<i>Probable Cause of Trouble</i>	<i>Remedy</i>	
<i>Low R-F Output</i>			
17. Low R-F output P.A. GRID or P.A. PLATE meter readings are abnormal. NOTE: Antenna current read on R-F Ammeter is not an accurate indicator of R-F output since the reading will vary with impedance of the antenna and frequency.	17a. Be sure CALIBRATE - TUNE - OPERATE switch is in OPERATE position.	17a. This switch must be in OPERATE position so that full screen voltage will be applied to power amplifier tube V104.	
	17b. Antenna tuning and loading controls may not be properly set.	17b. Check settings of C, D, and E Controls by operating on a frequency above 3000 Kc and using adjustment procedure starting with paragraph 6b(4)(o) in section*II.	
	17c. Antenna Shunt Capacitor Unit is connected to transmitter at all times.	17c. If Shunt Capacitor Unit is not disconnected when frequencies above 3000 Kc are used, a reduction in R-F output will result. Capacitor Unit should only be used when required to tune and load antenna in 2000 to 3000 Kc range. (See par. 6b(2)(jj) in sec. II.)	
	17d. If following condition cannot be obtained with VFO operation, the fault is in the power amplifier or exciter circuits (VFO oscillator or multiplier stages) P.A. PLATE meter reading should rise to at least 150 divisions when control "D" is detuned from its correct (resonant) setting, provided that P.A. GRID reading is between 40 and 140. NOTE: If P.A. PLATE reading is above 200 and P.A. GRID is not less than 40, then power amplifier tube V104 is causing trouble (it is "soft" or "gassy"). Replace it.	17d. If both P.A. PLATE and P.A. GRID readings are low, fault is likely to be in circuits associated with power amplifier tube V104. Check voltage from tube socket terminals to ground using table 5-1. WARNING: Plate connection at cap on top of tube V104 operates at 1150 volts. Turn off equipment and check resistance from tube terminals to ground using table 5-3. If P.A. PLATE reading is above 150, and P.A. GRID is below 40, then fault is in multiplier or oscillator circuits. Check circuits associated with tubes V103, V102, V101 and V2601 by measuring voltages and resistance to ground using tables 5-1 and 5-3. Be sure tubes have been checked. Check for poor contacts at switches S103, S102, S114, S115, and S101. If fault is not found, then tuned circuits may be out of alignment. Check alignment of multiplier and oscillator circuits as described in paragraph 5 of this section.	
	17e. If crystal-controlled operation is employed (AN/ART-13B only), and the multiplier and power amplifier circuits appear normal, the trouble lies in the CDA-T Crystal Oscillator unit.	17e. Using table 5-5A, check the tube terminal to ground resistance of both V801 and V802. Low crystal activity will result in lowered P.A. GRID drive, and usually a corresponding reduction of R-F output. New crystals may remedy this condition. In crystal-controlled, low frequency operation, a variable choke (L803) permits resonating the oscillator circuit for maximum output. Since this choke is used for all four low frequency outputs, its setting must accordingly be a compromise to permit satisfactory operation on all channels. If only one low frequency channel is to be used, the choke may be adjusted for maximum output at the single frequency. This choke is readily accessible from the top of the CDA-T unit, near the cap of V802.	
	18. Voice signal is considerably distorted when heard on liaison receiver.	18a. If voice sounds distorted when heard through sidetone jack of transmitter, fault is likely to be in speech amplifier circuits. NOTE: Try using another microphone. Be sure microphone switch under chart panel is in correct position (see fig. 2-2).	18a. If replacing tubes V201, V202, and V203 does not correct the trouble, remove Audio Amplifier Unit chassis from the transmitter (use procedure in paragraph 3b(4)(d), this section). Make up extension cable and plug so that unit can be connected to plug in transmitter. Measure voltages and resistance to ground from all tube terminals using tables 5-1 and 5-3 in this section. Check for short in capacitors C209 and C210. (Refer to fig. 8-11 for location.)

Excessive Distortion of Voice Emission

TABLE 5-2. TROUBLE SHOOTING AT REPAIR STATION (Cont'd)

Faults In Transmitter Unit (Cont'd)

<i>Symptoms</i>	<i>Probable Cause of Trouble</i>	<i>Remedy</i>
<i>Excessive Distortion of Voice Emission (continued)</i>		
	18b. If voice is not distorted when heard through sidetone jack on transmitter, the fault is likely to be in modulator and power amplifier circuits.	18b. Try replacing both modulator tubes V105, V106 and power amplifier tube V104. Check condition of resistors R121 and R123. If no improvement is obtained, measure voltages and resistance to ground from tube terminals using tables 5-3 and 5-5. WARNING: Plate connection caps at top of these tubes operates at 1150 volts. Check contacts 6, 7, and 8 of CW relay K103 (see fig. 8-42). When emission switch is on VOICE, contacts 6 and 7 of K103 should be open and 7 and 8 should be closed.
<i>"Beat Note" Is Not Heard When Attempting To Calibrate</i>		
19. When attempting to calibrate oscillators, using the CFI unit, a "beat note" cannot be obtained. It is assumed here that R-F output of transmitter is O.K. and when VOICE emission is used, the signal can be heard through sidetone jack.	19a. Be sure CALIBRATE - TUNE - OPERATE switch is in CALIBRATE position.	19a. CFI Unit will not operate if switch is not in CALIBRATE position.
	19b. Defective Crystal in CFI Unit.	19b. Replace Crystal in CFI Unit. Be sure tubes V2201, V2202, and V2203 are all O.K.
	19c. Poor contact at CALIBRATE-TUNE-OPERATE switch.	19c. Refer to figures 4-10 and 8-42. Check contacts on switch S106.
	19d. Poor contact at plug that connects CFI Unit to transmitter chassis.	19d. Check for loose plug connection under CFI Unit Chassis (see fig. 8-9).
	19e. Fault in circuits of CFI Unit.	19e. Remove CFI Unit Chassis from transmitter (see procedure in paragraph 3b(4)(e), this section). Make up extension cable and plug so that unit can be connected to plug in transmitter. Measure voltages and resistance from tube terminals to ground using tables 5-3 and 5-5 in this section.
	19f. If no fault is found in the circuits after checking as described in 19e, it is probable that the alignment of the CFI Unit has been disturbed and realignment will be required.	19f. Realign tuned circuits of the CFI Unit using procedure in paragraph 6 of this section.
<i>Autotune System Will Not Operate</i>		
20. Autotune mechanism does not operate when CHANNEL selector switch is operated.	20a. Be sure REMOTE-LOCAL switch is in LOCAL position.	20a. This switch must be set to LOCAL when using Controls on the transmitter. If Pilot's Control Unit is used, set switch to RFMOTE.
	20b. Telegraph Key, Throttle Switch, Test Switch or Microphone Switch is closed.	20b. Autotune mechanism cannot operate when transmitter is being keyed. See circuit in Figure 4-20.
	20c. Faulty contact at CHANNEL Selector Switch S108, Circuit Seeking Switch S109, Rear Limit Switch S111, Motor Control Relay K101, or contacts No. 2 and No. 12 of Keying Relay K102. (Numbers refer to plug terminals on side K102 case.)	20c. Check contacts at switch S108. Remove panel around bottom row of Controls (see fig. 8-1). See figure 8-3 for location of K101, S111, S109. Check contacts by referring to figure 4-2 or description of sequence of operation given in paragraph 3c of section IV (also see fig. 4-21).
	20d. Fault in Autotune motor.	20d. Determine whether motor will run when connected directly to a 28-volt D.C. source. See upper left corner of figure 8-42 for motor connections. Check motor brushes.
	20e. Check for mechanical binding of Autotune line shaft that might cause motor to stall.	20e. Attach Autotune line shaft crank at end of shaft that extends through right end of high frequency oscillator casting (see fig. 8-6). Crank is supplied with spare parts. Rotate line shaft to check for binding.

TABLE 5-2. TROUBLE SHOOTING AT REPAIR STATION (Cont'd)

<i>Faults In Transmitter Unit (Cont'd)</i>		
<i>Symptoms</i>	<i>Probable Cause of Trouble</i>	<i>Remedy</i>
<i>Autotune Does Not Return Controls to Correct Settings</i>		
21. Autotune mechanism operates but does not return the controls to the correct positions to which it was originally set.	21a. Be sure Autotune was set up properly.	21a. When Autotune is being set-up, be sure that Control knobs are ROTATED CLOCKWISE as final setting is approached. If you accidentally rotate knob past the setting, turn it back and again approach final setting by turning clockwise.
	21b. Autotune mechanism runs for very brief interval but does not set controls correctly; caused by poor contact at forward Limit Switch S112 or failure of contacts No. 5 and No. 6 to close on Motor Control Relay K101 (see fig. 8-42 for contact numbers).	21b. When mechanism is at rest, contacts of Forward Limit Switch S112 must be closed; check continuity. See figure 4-20. When Motor Control Relay K101 is operated, contacts No. 5 and No. 6 must be closed. (See fig. 8-42.) Check continuity.
	21c. Autotune motor runs continuously.	21c. See symptom 22.
	21d. Autotune mechanism returns some control knobs to correct setting but one or more knobs are still set incorrectly; caused by broken pawl spring, sticking pawl on multi-turn head, or improper synchronization of Autotune units or improper synchronization of Circuit Seeking Switch, S109.	21d. Examine all five Autotune mechanisms for broken pawl springs (see figs. 4-15 to 4-18 inclusive and fig. 4-14). If broken spring is found, replace that particular mechanism entirely. (Complete mechanisms and their part numbers are shown in figs. 4-15 through 4-18.) Check for sticking pawls (fails to fully engage slot in cam). Check synchronization of mechanisms and synchronization of Circuit Seeking Switch S109 as described in paragraphs 4b and 4d of this section.
<i>Autotune Motor Runs Continuously</i>		
22. Motor can be heard running continuously after control knobs have stopped tuning.	22a. Forward Limit Switch S112 fails to open when switch operating arm reaches maximum forward position. See figure 4-20.	22a. Adjust Forward Limit Switch S112 as described in paragraph 4e of this section.
	22b. Rear Limit Switch S111 fails to open when switch operating arm reaches home stop position. See figure 4-20.	22b. Adjust Rear Limit Switch S111 as described in paragraph 4e of this section.
	22c. Contacts 5 and 6 of Motor Control Relay K101 fail to open after forward limit switch opens.	22c. Check for sticking contacts on relay K101.
<i>Faults In Dynamotor Unit</i>		
WARNING		
High voltages (400, 750, and 1150) are present in the dynamotor power unit when dynamotor is running.		
<i>Dynamotor Will Not Operate</i>		
23. Dynamotor does not operate when equipment is turned on. NOTE: When EMIS- SION switch is in VOICE position dynamotor only operates when microphone switch, TEST switch, or throttle switch is closed.	23a. Transmitter Overload Relay K2705 (S2701 in Eicor dynamotor) or Primary Power Contactor Relay K2702 is open.	23a. Relay K2705 should be closed at all times. If overload occurs it will open. To re-close push button labeled TRANS. RESET. Relay K2702 should close when transmitter is turned on. If it does not, see cause No. 25b.
	23b. Dynamotor Overload Relay K2706 (S2702 in Eicor dynamotor) is open.	23b. Push DYNA. RESET button and attempt to close relay. If it closes momentarily and then opens again, there is an overload caused by a shorted part in the Dynamotor chassis or a defect in the Dynamotor Machine. Check for shorts in both the 28 volt input and the 400 and 1150 volt output circuits. See figure 8-42. Check resistance of dynamotor windings against table in paragraph 3g of section VI.

TABLE 5-2. TROUBLE SHOOTING AT REPAIR STATION (Cont'd)

Faults In Dynamotor Unit (Cont'd)

<i>Symptoms</i>	<i>Probable Cause of Trouble</i>	<i>Remedy</i>
<i>Dynamotor Will Not Operate (continued)</i>		
	23c. Faulty contacts or defective Primary Power Contactor Relay K2703.	23c. Contacts on this relay should be closed if emission switch on transmitter is in CW or MCW position. See figure 8-24 for location of relay K2703. Check armature winding of relay for continuity.
	23d. Worn brushes or defective dynamotor.	23d. Remove end covers of dynamotor and inspect brushes. Brushes shorter than 1/4" should be replaced. Clean Commutator with Carbon Tetrachloride and a cloth (NEVER USE EMERY CLOTH). Check for 28 volts on input terminals of dynamotor. If power is available but unit will not run, replace it.
<i>Transmitter Overload Relay Opens—No Fault In Transmitter</i>		
24. Overload relay K2705 (Eicor S2701) opens. When TRANS. RESET button is pushed, relay may stay closed only momentarily and immediately opens again.	24a. Overload caused by short circuit in wiring from output of this relay to terminal on receptacle J2701. 24b. Defective relay.	24a. Check wiring for shorts. See circuit in figure 8-42. 24b. If no short is found, replace relay.
<i>Transmitter Will Not Turn On—28 Volt Supply From Dynamotor to Transmitter Is Open</i>		
25. Equipment will not operate at all.	25a. Overload relay. Relay K2705 (S2701 in Eicor dynamotor) is open (no overload in transmitter). 25b. Primary Power Contactor Relay K2702 fails to close when equipment is turned on.	25a. Push button labeled TRANS. RESET. If relay closes momentarily and then opens again, and overload exists, check for shorts in wiring from this relay to receptacle J2701. If relay does not close, replace it. 25b. Check contacts of this relay (see fig. 8-24 for location). Check for voltage (28v) at relay armature. If voltage is available but relay doesn't work, replace it. If voltage is not available check circuit. (See fig. 4-2.)
<i>Fuse Blows—No Fault In Transmitter</i>		
26. Fuse on dynamotor unit blows but there is no short or overload in 400 volt circuits of transmitter.	26a. Short in wiring of dynamotor unit.	26a. Check for short in wiring from fuse to receptacle J2701. (See fig. 8-42.)
<i>High Voltage Is Not Reduced At High Altitudes—Causes "Flashover"</i>		
27. 1150 volt supply is not reduced to 750 volts at altitudes above 20,000 to 25,000 feet.	27a. Failure of Power Change Relay K2701. 27b. Failure of Pressure Operated (Barometric) Switch K2704 (S2703 in Eicor dynamotor).	27a. Check contacts of this relay (see fig. 8-24 for location). Check whether relay will operate when contacts of Pressure Operated Switch K2704 (S2703 in Eicor dynamotor) are shorted. (See fig. 8-41A and 8-42.) 27b. The contacts of this switch are normally open and will only close when pressure is reduced to correspond with altitude of approximately 25,000 feet. Failure of switch to close is cause of trouble.
<i>Dynamotor Unit Is Not Supplying 400 and 1150 Volts To Transmitter</i>		
28. Plate and screen voltage supply to transmitter is open.	28a. 400 volt supply may be open because of blown fuse. 28b. 1150 volt supply may be open because of poor contacts on Power Change Relay K2701.	28a. See symptom No. 26. Check brushes and commutator on 400 volt output of dynamotor. Clean commutator with Carbon Tetrachloride and cloth; blow out dust (NEVER USE EMERY CLOTH.) 28b. Check continuity of relay contacts. See figure 8-24 for location of relay.

TABLE 5-2. TROUBLE SHOOTING AT REPAIR STATION (Cont'd)

Faults in Dynamotor Unit (Cont'd)

<i>Symptoms</i>	<i>Probable Cause of Trouble</i>	<i>Remedy</i>
<i>Dynamotor Unit Is Not Supplying 400 and 1150 Volts To Transmitter (continued)</i>		
	28c. Worn brushes in high voltage output of dynamotor.	28c. Check brushes and commutator. Clean commutator with Carbon Tetrachloride and cloth (NEVER USE EMERY CLOTH). Blow out dust.
	28d. Fault caused by open choke coil or resistor.	28d. Check all component parts, associated with high voltage circuits, for continuity.
<i>Radio Frequency Interference ("Hash")—Caused by Dynamotor</i>		
29. Radio frequency interference causing noise in transmitter and associated equipment. (May also disturb other equipments.)	29a. Caused by improper installation of dynamotor brushes.	29a. When replacing brushes, note that each brush is numbered and that corresponding number is stamped on frame of dynamotor. Always use brush with corresponding number when replacing. Also it is very important that if brush is removed for inspection that it be replaced in same position. This is accomplished by having numbered (or marked) side of brush face the number (or mark) stamped on the frame of dynamotor.
<i>Faults In Control Unit</i>		
30. Emission Control does not operate.	30a. LOCAL-REMOTE switch on transmitter is in LOCAL position.	30a. Set switch to REMOTE position.
	30b. Poor contact on EMISSION selector Switch S602.	30b. Inspect switches in the control unit. Check continuity. See circuit in figure 8-42.
31. CHANNEL Selector does not operate.	31a. See 30a above.	31a. See 30a above.
	31b. Poor contact on CHANNEL selector Switch S601.	31b. Inspect switches in the control unit. Check continuity. See circuit in figure 8-42.
32. Red Indicator Light will not turn on.	32a. Lamp burned out.	32a. To replace bulb in the control box, remove red glass window by grasping knurled edge and pulling away from case. Lamp has bayonet base. The control panel has a screw type lamp and dimmer assembly. Replace the whole assembly.
	32b. See 30a above.	32b. See 30a above.
	32c. Lamp should be off when Autotune mechanism is in motion.	32c. Lamp should turn on as soon as Autotune mechanism completes the shift from one frequency to another.
<i>Faults In Antenna Load Unit</i>		
33. No R-F output when transmitter is operated in channels 1 through 12.	33a. Faulty contact in Vacuum Switch S2504 which is in Antenna Load Unit.	33a. Check vacuum switch S2504 for continuity. See circuit in upper left corner of figure 8-42.
	33b. Faulty contact in Antenna Selector Switch S2503.	33b. Check contacts of Antenna selector switch S2503 located in Antenna Load Unit. See figure 8-22 for location of switch.
34. No R-F output when transmitter is operated in channel 13.	34a. Break-in Relay K2501 fails to operate. This relay should operate when TEST switch or telegraph key is closed. Failure may be due to loose contact at Plug U-12/U or Receptacle J2501; or due to faulty Relay K2501.	34a. Check for loose contact or connection at plug U-12/U and receptacle J2501. Check continuity of wiring to relay K2501 and coil of relay. If relay coil is open, replace entire relay.
	34b. See 33a.	34b. See 33a.
	34c. Poor contact at fine or coarse Loading Switches S2501 and S2502.	34c. Check for poor contacts by making continuity measurements with equipment turned off.
	34d. Open winding in Inductors L2501 and L2502.	34d. Check for continuity of Inductors.

TABLE 5-2. TROUBLE SHOOTING AT REPAIR STATION (Cont'd)

<i>Symptoms</i>	<i>Probable Cause of Trouble</i>	<i>Remedy</i>
<i>Faults In Antenna Load Unit (continued)</i>		
	34e. Capacitors C2501 or C2502 are shorted.	34e. Make continuity check of capacitors. If capacitors are very warm, a high resistance short may be indicated.
35. Short circuit in Load Unit causes overload relay on dynamotor to open up.	35a. Short in 28 volt leads to Relay K2501.	35a. Turn off equipment, check for short by making continuity measurements from the 28 volt leads to ground.
36. Meter on Load Unit does not operate. R-F output is O.K.	36a. Fault may be caused by loose connection or open in Capacitors C2501 or C2502.	36a. Check for break in wiring or loose connection. If meter is OK, check condition of capacitors C2501, C2502, and resistors R2501 through R2505.
	36b. Defective meter.	36b. This thermocouple type R-F ammeter may be checked by passing either AC or DC current through it (meter is rated at 5 amperes). Current should not exceed rating of meter.
<i>Faults In Shunt Capacitor Unit</i>		
37. Shorted capacitor causes shorting of R-F output. P.A. PLATE meter reading is very high.	37a. Shorted capacitor section may get quite warm. Check capacitor by replacing with a new unit.	37a. Replace capacitor sections as required.
38. Transmitter loading circuits cannot properly tune and load antennas 20 to 60 feet long in frequency range 2000 Kc to 3000 Kc.	38a. Defective capacitor section or sections in antenna shunt capacitor.	38a. Replace individual capacitor sections as required.
<i>* Faults In CDA-T Crystal-Controlled Oscillator Unit</i>		
39. Improper channel or crystal selection.	39a. Faulty relays.	39a. Relay K106 selects the type of operation—VFO or Crystal-controlled. It must be energized for crystal operation and open or shorted relay coil, or dirty contacts will prevent proper operation.
		Relay K811 switches channels from the "A" to "B" group of frequencies. The relay must be energized to select "B" channels. Coil and contacts may cause faulty operation.
		Relays K801 through K810, individually control one channel, consisting of both an "A" and "B" frequency. The same difficulties may be experienced as listed above.
40. Low or no output.	40a. Faulty R-F chokes.	40a. One choke (L801) in the screen grid lead of V801 and two chokes (L802 and L803) in the plate lead of V802 provide B plus voltages. Open chokes will result in failure of the oscillator circuit to function.
41. Unit does not function at all.	41a. Faulty connectors or improper unit seating.	41a. This unit uses two connector plugs which connect with receptacles of the transmitter chassis. Due to slight variations of plug centering, the unit may not seat properly into the receptacles. If force is used to seat them, one or more of the plug terminals may be broken. By removing the transmitter side panel and the Audio Amplifier unit, the two plugs of the CDA-T unit may be observed as the unit is seated into place. It is possible to vary the plug locations by loosening the two screws fastening each plug. When installing the CDA-T unit, tilt the unit so that the front panel is worked into place first. Be sure to connect the two short leads which feed the oscillator output to the multiplier stage of the transmitter proper. Check to see that tubes and crystals are firmly seated in their sockets.

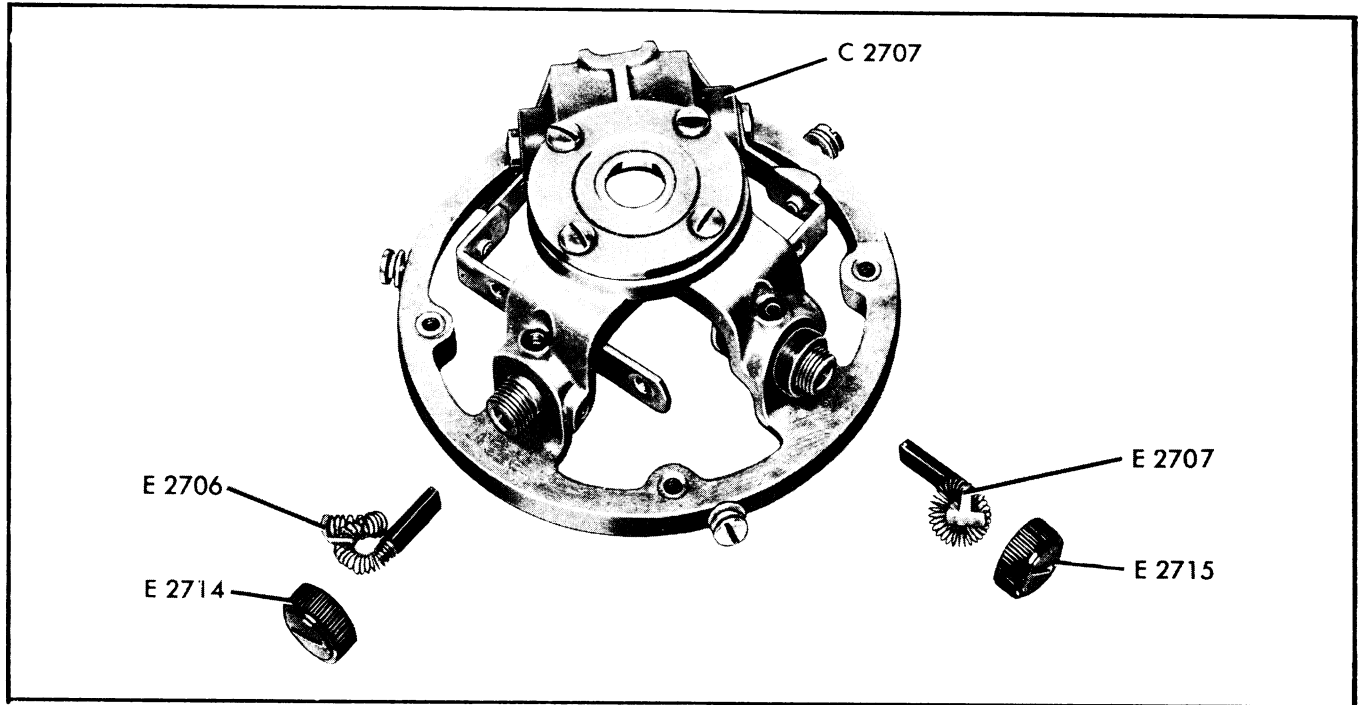

Brush Housing Assembly for 400-Volt Commutator

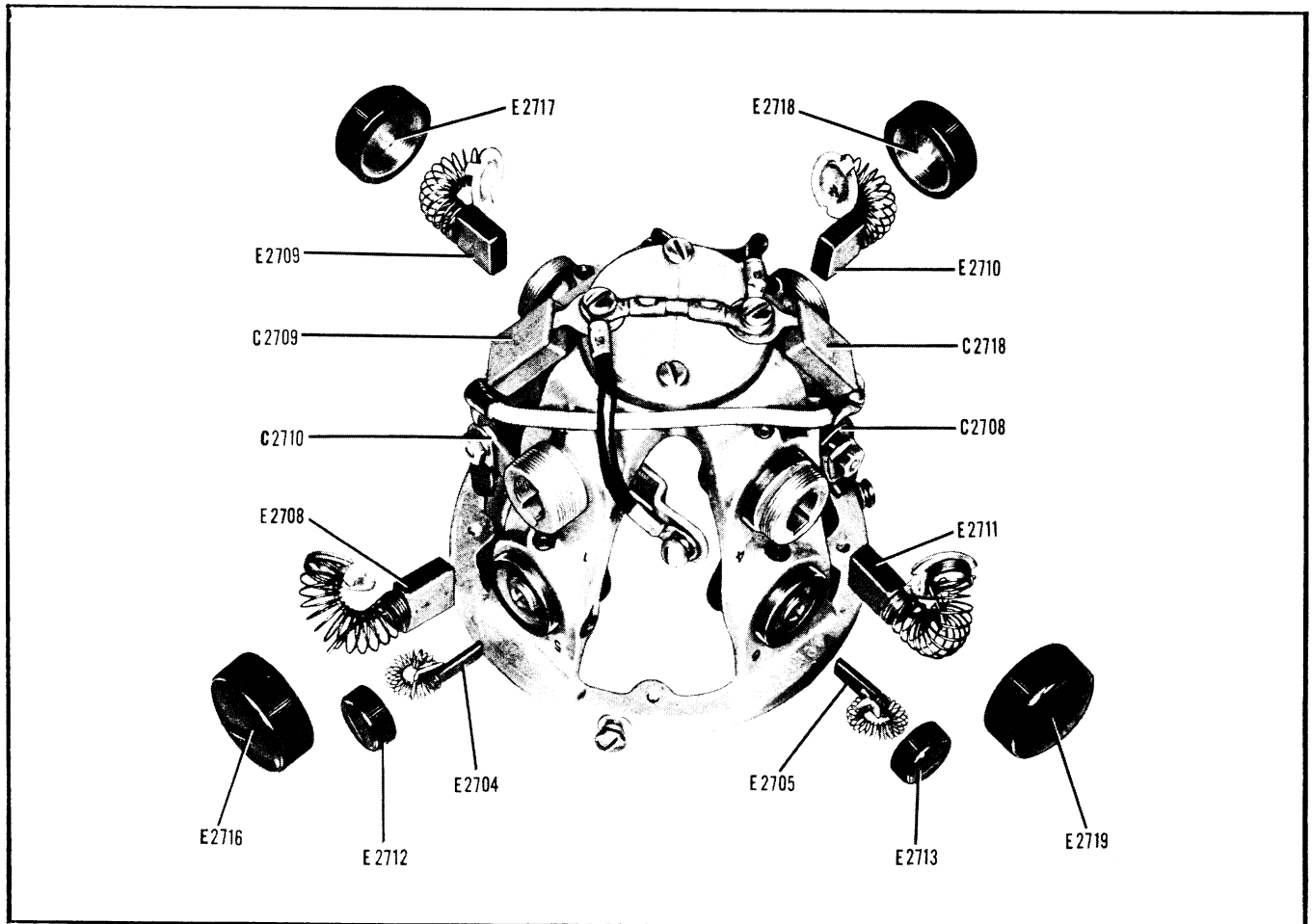

Brush Housing Assembly for 28-Volt and 750-Volt Commutators

Figure 5-2. Location of Brushes on Russell Dynamotor

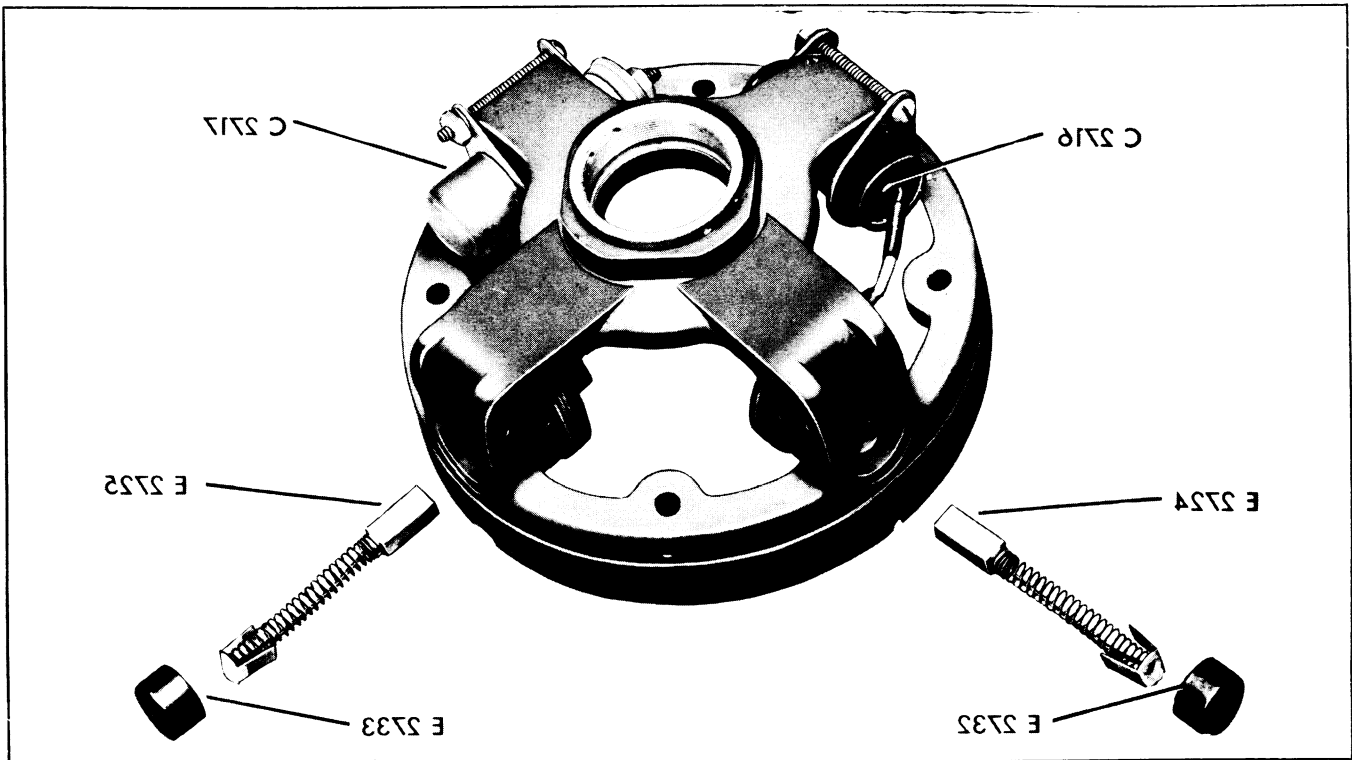

Brush Housing Assembly for 400-Volt Commutator

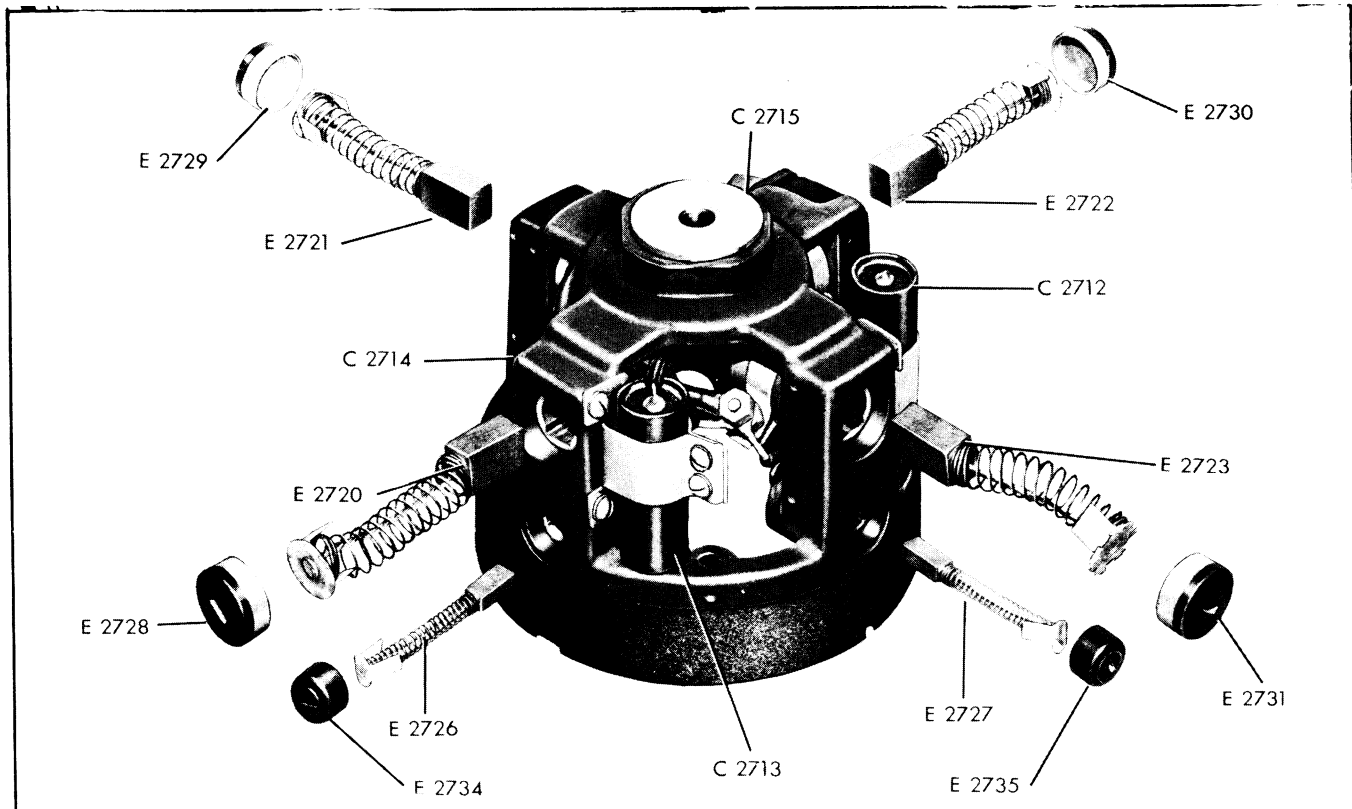

Brush Housing Assembly for 28-Volt and 750-Volt Commutators

Figure 5-3. Location of Brushes on General Electric Dynamotor

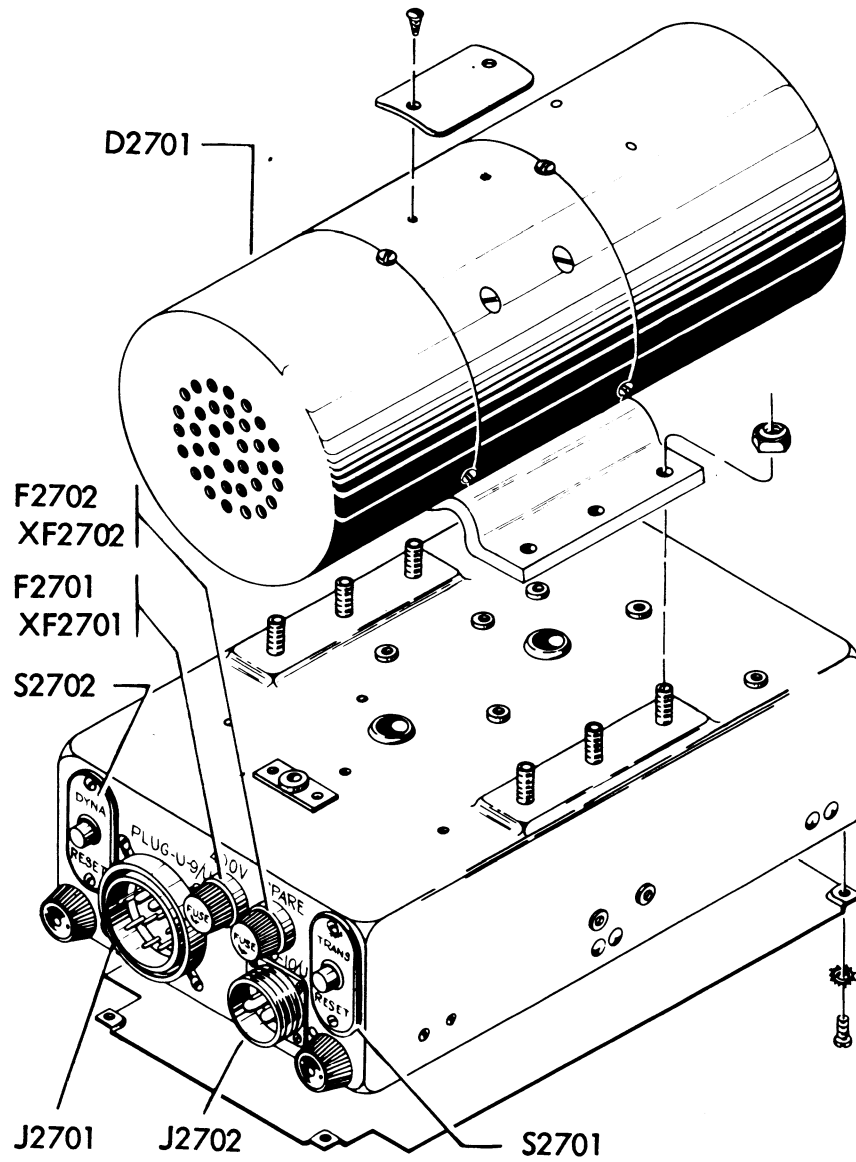

Figure 5-3A. Initial Disassembly of Eicor Dynamotor

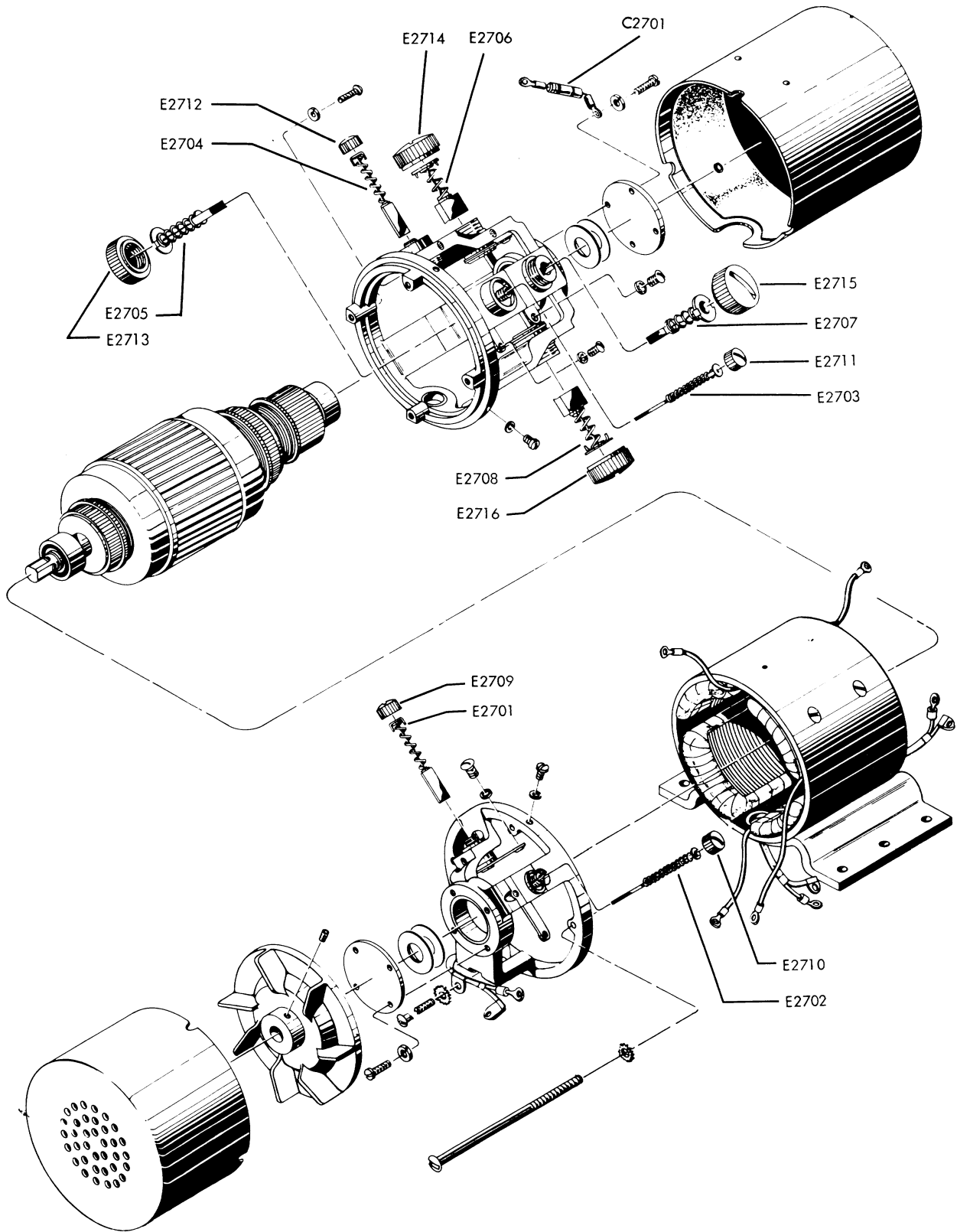

Figure 5-3B. Exploded View of Eicor Dynamotor

b. REMOVING AND SERVICING MAJOR ASSEMBLIES—OBTAINING ACCESS TO PARTS.—The procedures to be used in removing major assemblies and the methods of obtaining access to component parts are described in the following paragraphs. These procedures should be used, when required, in order to avoid unnecessary labor and to minimize the amount of disassembly required.

(1) **DISASSEMBLY OF PILOT'S CONTROL UNIT.**—Remove mounting plate by means of four screws at each corner of case. Inner cover plate is then removed by taking out two screws at each side of case (screws are nearest to back mounting surface). All components are now readily accessible.

(2) **DISASSEMBLY OF CONTROL PANEL.**—Remove the panel from the rack and disconnect the cable.

(3) **DISASSEMBLY and SERVICING THE DYNAMOTOR UNIT.**—If it is desired to obtain access to brushes and commutators of the dynamotor, this may be accomplished by removing the two end covers. These covers are held in place by 3 screws that are accessible on the rounded surface of the machine. Three sets of brushes are used in the dynamotor. The 28 volt and 750 volt commutators are located on the end of the dynamotor nearest the connector plugs. The 400 volt commutator is at the opposite end of the machine. The location and method of removal of the brushes used in the Russell and G.E. Dynamotors is shown in figures 5-2 and 5-3. Disassembly of these

dynamotors is illustrated in figures 5-4 and 5-5. Both disassembly and method of brush removal for Eicor Dynamotor DY-17A/ART-13A are shown in figure 5-3B. *Lubrication of the RUSSELL, G.E. or EICOR DYNAMOTORS is not required.*

When brushes are removed for inspection, it is extremely important that they be replaced in the same position (do not reverse). Brushes with numbers or POLARITY stamped on one surface should always be installed with the numbered surface, (or POLARITY SYMBOL) facing the corresponding number (or POLARITY SYMBOL) stamped on the frame of the dynamotor. Radio Frequency noise ("hash") may be caused by improper installation of brushes. New brushes may cause noise for a brief interval until they are "run-in." Brushes which are worn down to 1/4" in length should be replaced.

(a) Copper dust on commutators may be removed by using a stream of compressed air to blow it out. Clean commutator with Carbon Tetrachloride and a cloth—*Never use emery cloth.*

(b) **ACCESS TO POWER CONTROL UNIT UNDER DYNAMOTOR.**—To obtain access to the chassis under dynamotor, loosen two mounting plate clamp nuts on end near connector plugs. Remove unit from mounting plate. Loosen screws around bottom rim of chassis and remove bottom cover plate. All parts in the chassis are now accessible. See figures 8-24 and 8-39 for identification of parts in control unit used with Russell and G.E. Dynamotors.

Eicor Dynamotor Unit DY-17A/ART-13A includes

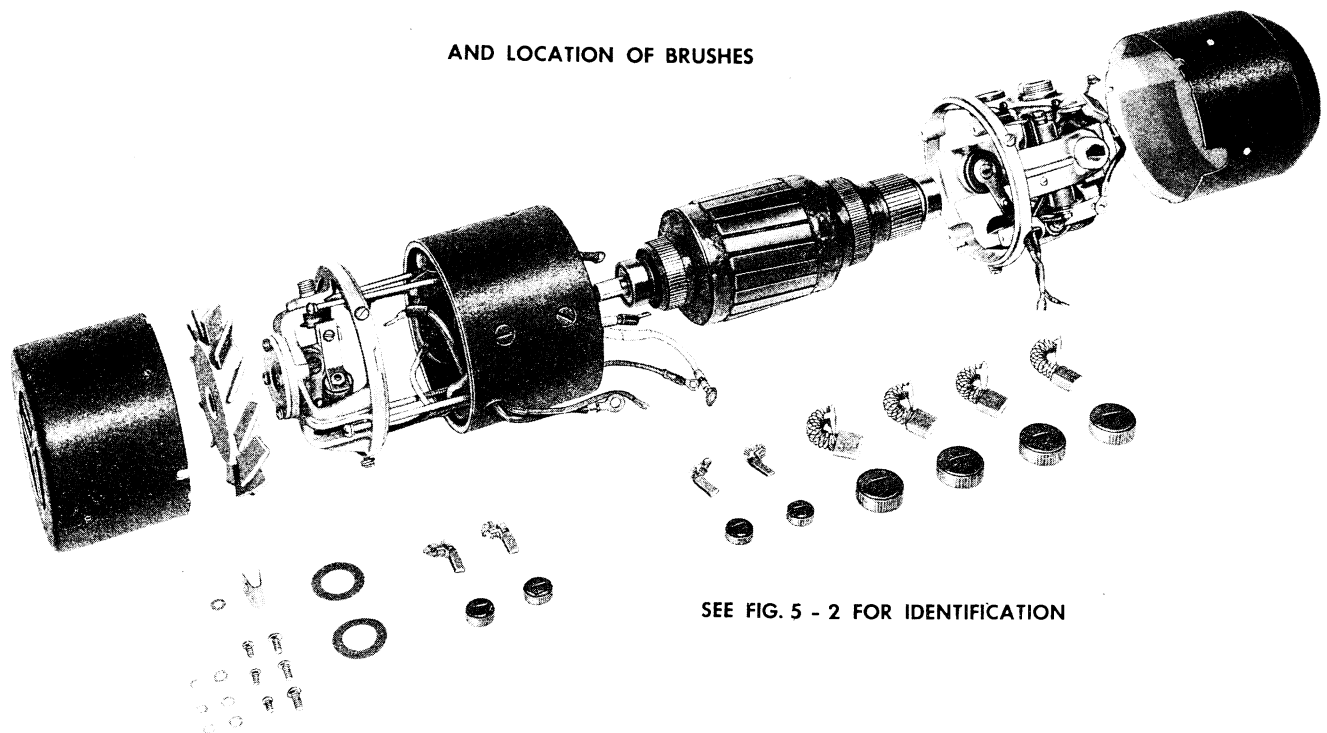
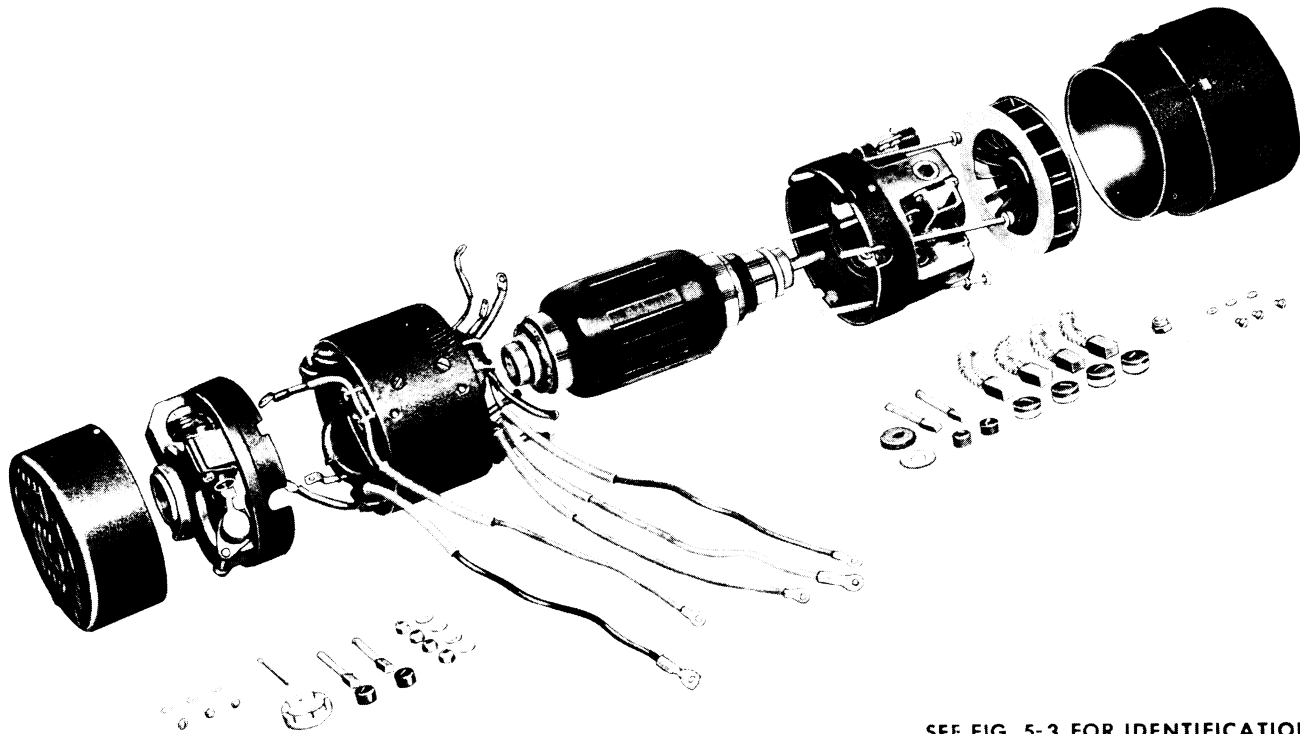

Figure 5-4. Component Parts of Russell Dynamotor



SEE FIG. 5-3 FOR IDENTIFICATION
AND LOCATION OF BRUSHES

Figure 5-5. Component Parts of General Electric Dynamotor

both the dynamotor proper and the control unit. Figure 5-3A shows the control unit with dynamotor and cover removed. For identification of parts in control unit, see figures 8-23A and 8-41A.

(c) REMOVING DYNAMOTOR.—Disconnect leads connecting dynamotor to power control chassis. Remove 3 nuts (on each side of dynamotor) that hold mounting bracket to chassis. Lift dynamotor and bracket off of chassis. Remove bracket by taking out screws holding it to dynamotor unit.

(4) DISASSEMBLY OF ANTENNA LOADING UNIT.—Remove unit from mounting plate by releasing snap slides on corners of case. Lift unit off of mounting plate. To obtain access to interior of the case, note that top and back of case are formed from a single plate of metal. This combined back and top panel is removed by taking about 15 screws at edges of top surface and 13 screws at edges of back surface. Panel may now be lifted off and all components on interior of case are accessible. Refer to figures 8-22 and 8-34 for identification of parts in the Antenna Loading Unit.

(5) DISASSEMBLY OF TRANSMITTER UNIT.—The transmitter unit contains three major assemblies that are equipped with multi-terminal plugs to permit removal without unsoldering any connections. These readily removable assemblies are the VFO Low Frequency Oscillator O-17/ART-13A (or in Model AN/ART-13B only, the CDA-T Crystal-Controlled Oscillator), the Audio Amplifier, and the MCW-CFI Unit. Figures 5-6 and 1-3A show the units removed from the equipment. Wrap-around sections and panels of the

transmitter case may also be removed to facilitate access to internal parts. The location of the part to be checked or removed will determine the section of case that must be removed.

(a) REMOVING WRAP-AROUND PANEL AT BOTTOM ROW OF CONTROLS—ACCESS TO AUTOTUNE MECHANISM AND MOTOR CONTROL RELAY K101.—To remove this panel (which is known as the Autotune front cover plate), take out 8 screws along top edge and 4 screws at each side. Pull panel forward over control knobs to remove it from the equipment. See figure 8-1 for identification of parts.

(b) REMOVAL OF BOTTOM PANEL—To remove this panel take out 3 screws at back and front edges respectively (3 in each channel) and lift off. This gives access to VOICE (K104) and CW(K103) RELAYS; see figure 8-3 for identification. In Model AN/ART-13B, only, removal of this bottom panel also gives access to VFO/XTAL RELAY (K106) and relay voltage dropping resistor (R138).

(c) REMOVAL OF OSCILLATOR PLUG-IN UNIT—O-17/ART-13A or *CDA-T.—Before attempting to remove either of these units, it should be noted that some components within the units are accessible from the top. In the CDA-T, the top is open; in the O-17/ART-13A, a top cover is used which is held in place by screws around the rim. To remove either unit, see figures 8-4, 8-5, 8-5A and 8-5B which show the complete units and then proceed as follows:

O-17/ART-13A (Removal):

1. Remove the connector wire from the right-hand side of the unit.
2. Remove the seven screws that hold the low-frequency oscillator panel in place.
3. Loosen adjacent screws along the top edge of the Autotune front cover plate.
4. Remove the plate lead from the JAN-813 power amplifier tube, V104, and remove the tube from the socket by inserting a screw driver through a ventilating hole in the back of the transmitter and using it as a lever between the tube base and the socket. Lift the tube out.
5. Insert a screw driver through the ventilating holes at the back of the transmitter and remove the screws that hold the back of the unit.
6. The unit is now free of all retaining screws and wires and may be removed from the transmitter by raising the rear edge of the oscillator unit to free the front panel from the Autotune cover plate. Then raise the unit until the connector plug is free.

* CDA-T (Removal and Disassembly):

1. Remove the two tubes, the crystal hold-down covers and all crystals.
2. Remove the two connector wires from the right-hand side of the unit.
3. Remove the one screw that holds the CDA-T rear plate to the transmitter chassis.
4. Loosen adjacent screws along the top edge of the Autotune front cover plate.
5. The unit is now free of all retaining screws and wires. It may be removed by lifting the rear edge until the front panel is free of the Autotune cover plate and then lifting until the two bottom connectors are free.
6. To disassemble, remove the six bottom screws and four rear plate screws, and the one center screw at the bottom of the front panel, which permits removal of the bottom and back plate. The connector which is mounted on the bottom of this plate should not be removed unless necessary, to avoid the necessity of realigning this plug for proper unit seating. Sufficient cable is attached to this connector to permit further disassembling and checking the unit.
7. Locate relay K811, which is mounted near the bottom of the left-hand side plate, when viewed from the front. Unsolder the lead at this relay which goes to pin #1 of the V801 tube socket.
8. Locate choke L801, which is under the center of the above lead mentioned in step 7. Unsolder or clip the lead which runs from this choke to the group of relays mounted on the left-hand side plate when viewed from the front.
9. Remove the three Phillips type screws on the left side of the front panel.
10. Remove the three Phillips type screws on the left-hand side plate, at the rear section of this plate.

The entire left plate may now be opened out to permit access to all parts of the unit. (See fig. 8-5B)

(d) REMOVAL OF AUDIO AMPLIFIER UNIT.—This unit is shown in Figures 8-10 and 8-11. To remove the unit from the equipment, proceed as follows:

1. Loosen the two large screws that hold the unit to the main transmitter chassis.
2. Remove the plate cap from the high-frequency oscillator, V101, and remove the tube from the socket.
3. Raise the unit until the multi-terminal plug becomes disengaged from the receptacle.
4. Slide the unit backward until the cabinet studs are cleared and raise the audio amplifier unit upward.

(e) REMOVAL OF MCW-CFI UNIT.—This unit is shown in Figures 8-8 and 8-9. To remove the unit from the equipment, proceed as follows:

1. Loosen the two large screws that hold the unit to the main transmitter chassis.
2. Raise the unit until the connector plug is disengaged.
3. Tip the unit toward the frequency multiplier tubes, V102 and V103, until the transformer clears the cabinet cover clamping bracket.
4. All circuit components are accessible from the bottom of the unit.

(f) ACCESS TO HIGH FREQUENCY OSCILLATOR AND MULTIPLIER PLATE TANK INDUCTORS.—Figure 8-6 shows the side view of this oscillator with all components readily accessible. To expose these parts, remove right side wrap-around panel of transmitter case by taking out the 7 screws in the rear and the 10 screws at the side of the case. An additional shield covers the section of the casting that houses the high frequency oscillator circuit components. If this inner shield is removed, all oscillator components will be exposed. *Removal of this inner shield will necessitate oscillator recalibration.* Do not remove the inner shield or make any adjustments of the h-f oscillator condensers or slug unless the calibration of this oscillator is thoroughly understood.

(g) REMOVING ENTIRE HIGH FREQUENCY OSCILLATOR CASTING.—Figure 8-6 shows this complete casting after removal from the equipment. Removal of this casting is not recommended unless absolutely necessary. When removing the casting, the following procedure should be used:

1. Remove the plate cap from the high-frequency oscillator tube, V101, unlock the tube base clamp and remove the tube from the socket.
2. Remove the MCW-CFI and the Audio Amplifier Units as outlined in the preceding paragraphs.
3. Remove the two screws that hold J111, the MCW-CFI Unit connector plug receptacle, to the standoffs and unsolder the single wire that connects

the high frequency oscillator tube V101 cathode to terminal 1 on J111.

4. Remove the Autotune cover plate and wrap-around section of the transmitter cabinet.

5. Remove the locking bar and dial from Control "A" by turning the dial locking bar to the unlocked position, loosening the two No. 10 Bristo set screws in the dial, and turning both locking bar and dial counterclockwise until free. Remove the dial back plate.

6. The Autotune Singleturn Unit adjacent to the High-Frequency Oscillator Multiturn Unit must be removed so that the screws that hold the oscillator casting to the Autotune casting may be loosened. To remove this unit loosen the short screw that holds the lower edge of the unit to the Autotune casting and the two long screws that hold the upper edge of the unit to the casting and lift the unit carefully out of position.

CAUTION

Care must be exercised not to move any of the Autotune mechanisms from the time the unit is loosened until the unit is again securely in place, otherwise the unit may be thrown out of synchronization.

7. When the Autotune Singleturn Unit has been removed, loosen the screws that hold the castings together in the front and top of the chassis.

8. To complete disconnecting the h-f oscillator, move the casting slightly to the right and unsolder the connections to the terminal strip on the inner side of the casting and the wires leading to the frequency multiplier plate tank inductors.

9. The h-f oscillator casting assembly may now be removed from the transmitter.

(b) REMOVAL OF FREQUENCY MULTIPLIER UNIT.—Figure 8-7 shows this unit after removal from the equipment. Some of the frequency multiplier circuit components are accessible from the bottom of the transmitter if the bottom cover plate is removed. To gain access to the remaining frequency multiplier circuit components, the multiplier unit must be removed from the assembly. The following procedure is recommended for the removal of the multiplier unit from the transmitter.

1. Remove the plate caps from the frequency multiplier tubes, V102, and V103, unlock the tube base clamps and remove the tubes from the sockets. Disconnect the Low Frequency Oscillator plate lead at the Oscillator end.

2. Remove the transmitter bottom cover plate and the Autotune cover plate.

3. Remove Autotune Unit "A" in the following manner: Turn the dial locking bar to the unlocked position and loosen the two No. 10 Bristo screws

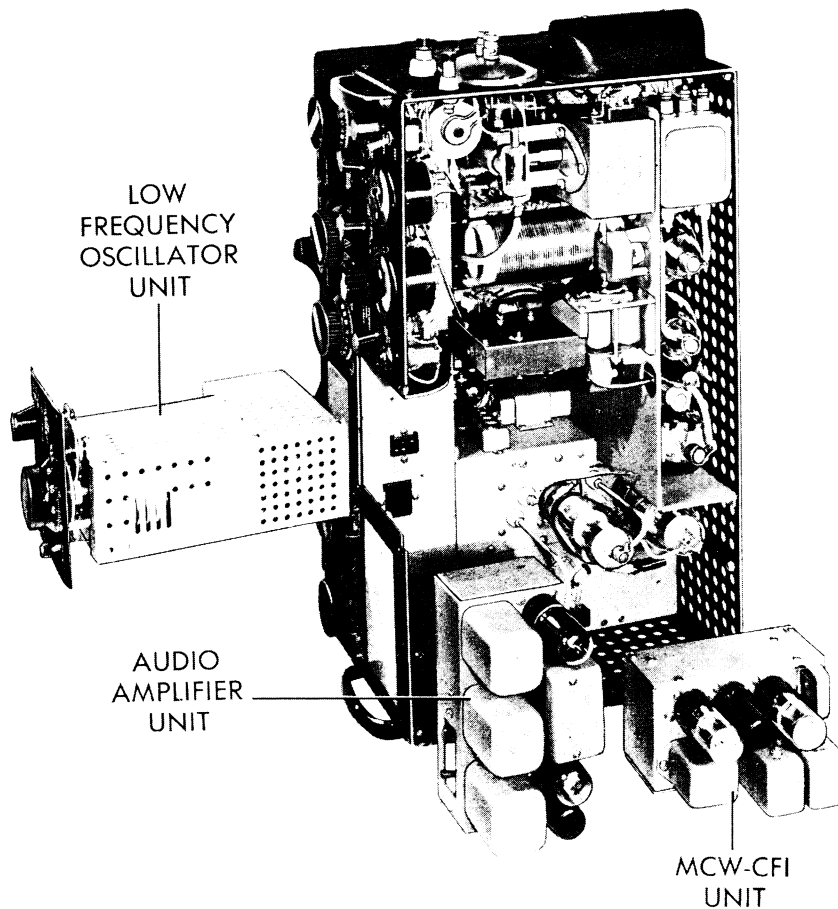

Figure 5-6. Radio Transmitter T-47A, ART-13 and Removable Units

TABLE 5-3. VOLTAGE-TO-GROUND FROM VACUUM TUBE TERMINALS

WARNING

In measuring voltages, extreme care should be exercised to prevent personal injury. Operating voltages in parts of this equipment are dangerous to human life. Be sure insulation of leads and test prods on voltmeter are rated high enough to protect personnel when used to measure voltages up to 1200 volts. Avoid high voltage measurements when other methods of circuit checking can be used.

1. USE 20,000 OHM/VOLT METER TO MEASURE ALL VOLTAGES.
2. SET POWER LEVEL SWITCH ON "OPERATE" POSITION TO MEASURE VOLTAGES ON ALL TUBES EXCEPT V2201, V2202, AND V2203. WHEN MEASURING VOLTAGES ON THESE THREE TUBES, SET SWITCH ON "CALIBRATE" POSITION.
3. SET EMISSION SELECTOR SWITCH ON MCW POSITION.
4. TUNE AND FULLY LOAD TRANSMITTER FOR OPERATION ON ANY FREQUENCY IN 6000 TO 7200 KC. FREQUENCY RANGE FOR MEASUREMENTS ON ALL TUBES EXCEPT V2601. WHEN MEASURING VOLTAGES ON TUBE V2601, TRANSMITTER SHOULD BE TUNED AND LOADED FOR OPERATION AT 400 KC.
5. HOLD TELEGRAPH KEY (OR "TEST SWITCH") CLOSED WHEN MAKING ALL MEASUREMENTS.

Tube Base Terminal Number	V101 JAN-837	V102 JAN-1625	V103 JAN-1625	V104 JAN-813	V105 JAN-811	V106 JAN-811	V201 JAN-12S17	V202 JAN-6V6GT	V203 JAN-6V6GT	V2201†JAN-12SL7GT	V2202†JAN-12S47	V2203†JAN-12SL7GT	V2601* JAN-1625
1	Heater 11	Heater 13.5	Heater O	Filament 10	Filament 10	Filament 23	Shield O	N.C. O	N.C. O	Grid No. 1 -5.6	Suppressor 4.0	Grid No. 1 -2.6	Heater O
2	Shield O	Shield O	Shield O	N.C. 420	N.C. O	N.C. O	Heater O	Heater 18	Heater 23	Plate No. 1 85	Heater 10.6	Plate No. 1 75	Shield O
3	Screen :00	Screen 300	Screen 350	Screen 420	Grid 10	Grid 16	Suppressor O	Plate 190	Plate 190	Cath. No. 1 O	Plate 75	Cath. No. 1 O	Screen 210
4	Grid -4.2	Grid -50	Grid -200	Grid -40	Filament 16	Filament 16	Grid O	Screen 200	Screen 200	Grid No. 2 -20.4	Screen 124	Grid No. 2 O	Grid -15
5	Suppressor O	N.C. -50	N.C. -200	Beam Form. O	—	—	Cathode 1	Grid O	Grid O	Plate No. 2 100	Grid No. 1 -21.5	Plate No. 2 120	N. C. 18
6	Cathode 14.5	Cathode 37	Cathode 65	N.C. O	—	—	Screen 18	N.C. O	N.C. O	Cath. No. 2 O	Cathode 4.0	Cath. No. 2 4.0	Cathode 18
7	Heater 23.5	Heater 23.5	Heater 13.5	Filament O	—	—	Heater 12	Heater 12	Heater 17.5	Heater O	Heater O	Heater 12.6	Heater 12.5
8	—	—	—	—	—	—	Plate 55	Cathode 8.5	Cathode 8.5	Heater 12.6	Grid No. 3 -2.7	Heater 25.2	—
Top Cap	Plate 410	Plate 430	Plate 420	Plate 1150	Plate 1150	Plate 1150	—	—	—	—	—	—	Plate 420

N.C. Indicates that this socket terminal does not connect to an element of the tube but merely serves as terminal post.
 †Set Power Level Switch on "Calibrate" position when measuring voltages on tubes V2201, V2202 and V2203.
 *Tune and load transmitter for operation on 400 KC before measuring voltages on tube V2601.

TABLE 5-4. VOLTAGE-TO-GROUND FROM CABLE CONNECTOR TERMINALS

WARNING

In measuring voltages, extreme care should be exercised to prevent personal injury. Operating voltages in parts of this equipment are dangerous to human life. Be sure insulation of leads and test prods on voltmeter are rated high enough to protect personnel when used to measure voltages up to 1200 volts. Avoid high voltage measurements when other methods of circuit checking can be used.

1. USE 20,000 OHM/VOLT METER TO MEASURE ALL VOLTAGES EXCEPT AS NOTED ON TERMINAL 27 OF J106 AND J601.
2. SET POWER LEVEL SWITCH ON "OPERATE" POSITION TO MEASURE ALL VOLTAGES EXCEPT THOSE ON J111 AND P2201. WHEN MEASURING VOLTAGES ON J111 AND P2201, SET SWITCH ON "CALIBRATE" POSITION.
3. SET EMISSION SELECTOR SWITCH ON MCW POSITION.
4. TUNE AND FULLY LOAD TRANSMITTER ON ANY FREQUENCY BETWEEN 6000 AND 7200 KC. FOR ALL MEASUREMENTS EXCEPT THOSE ON J107, J114, AND P2601. TO MEASURE VOLTAGES ON THESE ITEMS, TRANSMITTER SHOULD BE TUNED AND FULLY LOADED AT 400 KC.
5. HOLD TELEGRAPH KEY (OR "TEST SWITCH") CLOSED WHEN MAKING MEASUREMENTS.

Term No.	H.F. Osc.	J106 J601		J107*	J108 J2701	J111† P2201		J112 P201	J114* P2601	J115 P101	J116 P102	J2702
		Loc.	Rem.			Cal.	MCW					
1	200	O	O	O	440	18	16	10	O	300	O	O
2	23.5	O	O	O	440	O	O	10.5	11	400	25	28
3	11	O	O	25	25	450	O	15.5	440	O	O	O
4	13	O	O	O	27	O	O	15.	210	24	O	O
5	O	O	O	O	O	450	415	O	32	45	430	O
6	O	O	O	O	27	O	O	210	O	14	O	O
7	O	O	O	O	0.3	O	O	23.5	O	14	O	O
8	O	O	O	O	0.4	23	23	O	O	23.5	O	O
9	O	O	O	O	440	O	O	23.5	O	O	O	O
10	O	O	O	O	1150	O	O	O	O	440	O	O
11	O	O	O	O	O	O	O	O	O	320	O	O
12	O	O	O	O	O	O	O	O	O	O	430	O
13	O	O	O	O	O	O	O	O	O	O	O	O
14	O	O	O	O	O	O	O	O	O	O	O	O
15	O	O	O	O	O	O	O	O	O	O	O	O
16	O	O	O	O	O	O	O	O	O	O	O	O
17	O	O	O	O	O	O	O	O	O	O	O	O
18	O	O	O	O	O	O	O	O	O	O	O	O
19	O	O	O	O	O	O	O	O	O	O	O	O
20	O	O	O	O	O	O	O	O	O	O	O	O
21	O	O	O	O	O	O	O	O	O	O	O	O
22	O	O	O	O	O	O	O	O	O	O	O	O
23	O	O	O	O	O	O	O	O	O	O	O	O
24	O	O	O	O	O	O	O	O	O	O	O	O
25	O	O	O	O	O	O	O	O	O	O	O	O
26	O	O	O	O	O	O	O	O	O	O	O	O
27	O	O	O	O	O	O	O	O	O	O	O	O

†Set Power Level Switch on "Calibrate" position when measuring voltages on J111 and P2201.

*Tune and load transmitter for operation on 400 KC before measuring voltages on J107, J114 and P2601.

**Use 1000 ohm/volt A.C. meter for this measurement. If receiver disabling is used, voltage on terminals No. 26 and No. 27 of J106 and J601 are the same.

TABLE 5-5. RESISTANCE-TO-GROUND FROM VACUUM TUBE TERMINALS.

1. SET CONTROL "A" TO POSITION 7 (6.0 Mc TO 7.2 Mc)

2. SET EMISSION SWITCH TO MCW POSITION

Tube Base Terminal	V101 (837)	V102 (1625)	V103 (1625)	V104 (813)	V105 (811)	V106 (811)	V201 (12SJ7)	V202 (6V6GT)	V203 (6V6GT)	V2201† (12SL7GT)	V2202† (12SA7)	V2203† (12SL7GT)	V2601** (1625)
1	4.0*	4.5*	O	0.3	0.2	0.4	O	O	O	33,000	330	470,000	O
2	O	Inf.	Inf.	175	Inf.	Inf.	O	4.0	2.5	Inf.	15	Inf.	Inf.
3	1250	20,000	20,000	200	90	85	O	1550	1530	O	O	28	1250
4	22,000	100,000	100,000	20,000	0.3	0.3	4,000	1300	1280	33,000	O	150,000	15,000
5	O	100,000	100,000	O	—	—	2,200	470,000	100,000	Inf.	47,000	100,000	Inf.
6	Inf.	1,000	1,000	O	—	—	1 Meg.	O	Inf.	O	330	330	Inf.
7	3	3	4.5	O	—	—	5	5	4.5	O	O	15	3
8	—	—	—	—	—	—	160,000	250	250	15	47,000	27	—
Top Cap	70	110	65	325	330	325	—	—	—	—	—	—	125

*When making this measurement, CALIBRATE-TUNE-OPERATE switch must be in CALIBRATE position.

**Set Control "A" to position 13 (L.F.) before making measurements on tube V2601.

†Remove MCW-CFI Unit from transmitter for these readings.

TABLE 5-6. RESISTANCE-TO-GROUND FROM CABLE CONNECTOR TERMINALS.

THESE MEASUREMENTS ARE TO BE MADE UNDER THE FOLLOWING CONDITIONS:

1. AUDIO AMPLIFIER UNIT, MCW-CFI UNIT AND LFO UNIT REMOVED
2. ALL PLUGS AND RECEPTACLES DISCONNECTED.
3. ALL TUBES IN PLACE.
4. EMISSION SWITCH SET TO MCW.
5. CHANNEL SWITCH SET TO NO. 1.
6. CONTROL "A" SET TO NO. 1.
7. LOCAL-REMOTE SWITCH SET TO LOCAL POSITION EXCEPT AS SPECIFIED FOR MEASUREMENTS ON J106.
8. MICROPHONE CIRCUIT SELECTING SWITCH SET TO "CARBON" POSITION.

Term. No.	H.F. Osc.	J106		J107		J108	C	J111		J112	J114	J115	J116	J2701	J2702	J601	P101	P102	P201	P2201	P2601
		Loc.	Rem.	H.F.	L.F.			T	O												
1	Inf.	180	Inf.	O	O	6,750	Inf.	Inf.	Inf.	Inf.	O	Inf.	Inf.	32	O	Inf.	24,000	Inf.	Inf.	Inf.	O
2	Inf.	O	O	80	Inf.	Inf.	Inf.	Inf.	Inf.	0.5	5.5	Inf.	180	45	Inf.	Inf.	6,750	Inf.	Inf.	Inf.	7
3	Inf.	O	O	Inf.	Inf.	13	Inf.	Inf.	Inf.	0.3	6,750	O	O	Inf.	O	Inf.	Inf.	Inf.	Inf.	Inf.	Inf.
4	Inf.	O	O	O	Inf.	13	Inf.	Inf.	Inf.	Inf.	5,000	Inf.	O	Inf.	Inf.	Inf.	Inf.	Inf.	Inf.	Inf.	Inf.
5	—	O	O	O	O	O	O	O	O	Inf.	Inf.	Inf.	Inf.	O	Inf.	Inf.	Inf.	Inf.	2 to 16	Inf.	Inf.
6	—	O	O	—	—	1.5	O	O	O	5,000	Inf.	Inf.	Inf.	Inf.	Inf.	Inf.	Inf.	Inf.	Inf.	Inf.	Inf.
7	—	O	O	—	—	O	Inf.	3.5	3.5	3.0	—	Inf.	Inf.	Inf.	Inf.	Inf.	125	Inf.	17	O	1 to 15
8	—	O	O	—	—	O	3.0	3.5	—	O	—	Inf.	Inf.	Inf.	Inf.	Inf.	Inf.	Inf.	O	23	—
9	—	O	O	—	—	Inf.	—	—	—	O	—	Inf.	Inf.	40	Inf.	Inf.	Inf.	Inf.	Inf.	Inf.	—
10	—	O	O	—	—	Inf.	—	—	—	Inf.	—	Inf.	Inf.	150	Inf.	Inf.	Inf.	Inf.	325	—	—
11	—	O	O	—	—	—	—	—	—	—	—	Inf.	Inf.	—	—	Inf.	7,000	Inf.	O	—	—
12	—	Inf.	180	—	—	—	—	—	—	—	—	Inf.	O	—	—	Inf.	26,000	Inf.	6.5	—	—
13	—	Inf.	O	—	—	—	—	—	—	—	—	6,750	—	—	—	Inf.	—	Inf.	—	—	—
14	—	150	150	—	—	—	—	—	—	—	—	Inf.	—	—	—	Inf.	—	—	—	—	—
15	—	O	Inf.	—	—	—	—	—	—	—	—	0.2	—	—	—	Inf.	—	—	—	—	—
16	—	120	120	—	—	—	—	—	—	—	—	—	—	—	—	Inf.	—	—	—	—	—
17	—	Inf.	150	—	—	—	—	—	—	—	—	—	—	—	—	42	—	—	—	—	—
18	—	78	80	—	—	—	—	—	—	—	—	—	—	—	—	O (Key Down)	—	—	—	—	—
19	—	O	O	—	—	—	—	—	—	—	—	—	—	—	—	O	—	—	—	—	—
20	—	Inf.	Inf.	—	—	—	—	—	—	—	—	—	—	—	—	Inf.	—	—	—	—	—
21	—	O	Inf.	—	—	—	—	—	—	—	—	—	—	—	—	Inf.	—	—	—	—	—
22	—	Inf.	O	—	—	—	—	—	—	—	—	—	—	—	—	Inf.	—	—	—	—	—
23	—	Inf.	Inf.	—	—	—	—	—	—	—	—	—	—	—	—	Inf.	—	—	—	—	—
24	—	Inf.	Inf.	—	—	—	—	—	—	—	—	—	—	—	—	Inf.	—	—	—	—	—
25	—	Inf.	Inf.	—	—	—	—	—	—	—	—	—	—	—	—	Inf.	—	—	—	—	—
26	—	Inf.	Inf.	—	—	—	—	—	—	—	—	—	—	—	—	Inf.	—	—	—	—	—
27	—	Inf.	Inf.	—	—	—	—	—	—	—	—	—	—	—	—	Inf.	—	—	—	—	—

LOC—LOCAL REM—REMOTE INF—INFINITE RESISTANCE C—CALIBRATE T—TUNE O—OPERATE

**TABLE 5-6A. RESISTANCE-TO-GROUND FROM TUBE AND CONNECTOR TERMINALS—CDA-T UNIT—
THESE MEASUREMENTS ARE TO BE MADE UNDER THE FOLLOWING CONDITIONS:**

1. Unit is removed from the transmitter.
2. All tubes in place.
3. All crystals removed.
4. VFO/XTAL switch in "VFO" position.
5. A/B switch in "A" position.
6. 4-Position switch in position 1.

Tube Base or Connector Terminal	V801 JAN-6AQ5	V802 JAN-1625	Connector P801 (15 Term.)	Connector P802 (6 Term.)
1	100 K	0	40	0
2	Infinity	Infinity	40	5
3	2.8	Infinity	40	Infinity
4	0	100 K	40	Infinity
5	Infinity	Infinity	40	Infinity
6	Infinity	Infinity	40	Infinity
7	—	5	40	—
8 or Plate Cap	—	Infinity	40	—
9	—	—	40	—
10	—	—	49	—
11	—	—	410	—
12	—	—	40	—
13	—	—	Infinity	—
14	—	—	Infinity	—
15	—	—	Infinity	—

Note: The above measurements were made with a vacuum tube voltmeter.

in the dial. Turn the dial and locking bar counterclockwise together until the bar comes free. Remove both the dial and the locking bar. Remove the dial back plate, loosen the two long screws on the top end of the unit and the short screw on the bottom end of the unit. Carefully lift the unit out.

CAUTION

Care must be exercised not to move any of the Autotune mechanisms from the time the unit is loosened until the unit is again securely in place, otherwise the unit may be thrown out of synchronization.

4. When the Autotune Singleturn Unit has been removed, remove the screws holding the seeking switch, S109, to the Autotune casting and swing the switch out.

5. Heat and remove the wires leading to the multiplier coils at the rear of the High Frequency Oscillator Unit. Heat and remove the bus wire connected to coupling capacitor C116.

6. Remove the two screws just behind the second multiplier tube clamp shell and the two screws just in front of the first multiplier tube clamp shell. Remove the actuating arm of S101.

7. The multiplier unit can now be pulled out sufficiently to remove the nut holding the ground wire lug on the side of the unit adjacent to the fire-wall assembly. Remove cable connector J115 from P101 in the multiplier unit.

8. The multiplier unit may now be lifted out of the transmitter.

9. In reassembling the transmitter it is essential that the shaft of seeking switch S109 be carefully centered with the cam drum shaft that drives it. This may be checked by referring to paragraph 4d(1), this section, except that the position of the switch and not the driving arm should be adjusted.

(i) ACCESS TO PARTS IN FIRE-WALL ASSEMBLY.—The majority of the component parts on this assembly are accessible from top or bottom of the transmitter. Figures 8-13, 8-14, 8-15, and 8-16 will identify and locate important parts of the fire-wall assembly and the multi-element switch. Also see figure 8-3 for similar information on other surrounding parts.

4. MAINTENANCE OF AUTOTUNE MECHANISM.

a. LUBRICATION.—See figure 4-14 for locations of points to be lubricated as described below. The letters inside the dotted circles in this figure denote the type of lubricant to be used at that point. The letters A, B, and C are identified with lubricants they represent at the bottom of the figure.

(1) Use AN-O-6 oil for all lubrication points except the open gears and pawls. The points to be lubricated with this oil include:

- (a) All line shaft bearings.
- (b) Autotune motor bearings.

(c) Front and rear cam drum bearings on each of the autotune units.

(d) All idler gear bearings.

(e) Counter drum bearings.

(f) Limit switch driven shaft bearings.

(2) AN-G-25 grease should be used on all gears.

These gears include:

(a) All line shaft worms.

(b) Worm gears on all autotune units.

(c) Spur and idler gears on all autotune units.

(d) The screw on the limit switch drive shaft.

(3) AN-G-10 or AN-G-25 grease should be used on the motor sprocket and chain assembly.

(4) Each of the three lubricants may be applied with a camel's hair brush to the various lubrication points. Only very small amounts of oil or grease are required at most points. Be sure to remove any excess oil or grease after lubricating the autotune system.

(5) It will not be necessary to remove the individual autotune units in order to lubricate the mechanism properly. The transmitter should be turned on its back and the autotune front panel removed for maximum access to the lubrication points.

b. SYNCHRONIZATION CHECK.—In order for the autotune system to function properly, the five individual units must be carefully synchronized. If there is any reason to doubt the accuracy of the synchronization, it should be immediately checked. This may be done as follows:

(1) Turn the equipment on its back so as to have maximum access to the units and remove the autotune front panel.

Note

If the counter drum rings in the multi-turn unit "B" have been moved for any reason so that a pawl cannot fall in the slot of a given ring within the range of the counter drum rotation, the ring must be moved manually a quarter turn in either direction.

(2) Place the crank (which is included in the spare parts) on the right end of the autotune line shaft, orient the crank hub in the slot, and fasten it with a 4-40 x 1/2" screw.

(3) By means of the crank, turn the line shaft counterclockwise until all the cam drums are being driven. Continue to turn the crank counterclockwise until the stop-ring drum on the multi-turn unit has reached home stop and has ceased to turn.

(4) After the stop-ring drum on the multi-turn unit has ceased to turn and only the cam drums are turning, pull the fork of the anvil (fig. 4-14) in a counterclockwise direction away from under the tails of the pawls so that they are free to fall to the surface of the counter drum. If at any time the line shaft should be turned clockwise, it will first be necessary to turn the line shaft again in the counterclockwise direction far enough to reach home stop before pulling

the anvil out from under the tails of the pawls; otherwise, as soon as the line shaft is turned counterclockwise, the anvil will be rotated up under the tails of the pawls.

(5) Continue to rotate the crank slowly until the No. 5 pawl on one of the units just drops into its cam slot.

Note

Count from the front of the autotune unit to the back, omitting the first or manual pawl, to arrive at pawl No. 5.

(6) Note the position of the crank arm by marking a line on the casting and then slowly turn the crank, noting the points at which the No. 5 pawls on all of the other units drop into the cam slots. All of the pawls should drop into place within a quarter turn ahead or behind the point where the No. 5 pawl on unit "A" engaged with its cam. All pawls should drop sharply with a "click."

(7) Continue to rotate the crank counterclockwise until the No. 6 pawl on one of the units, just drops into its cam slot.

(8) Note the position of the crank arm by marking a line on the casting and then slowly turn the crank, noting the points at which the No. 6 pawls on all of the other units drop into the cam slots and repeat the procedure outlined in step (6).

(9) Repeat steps (7) and (8) above, checking operation of pawls No. 7, 8, 9, 10, 11, 12 (L. Freq.), manual, 1, 2, 3, and 4.

c. SYNCHRONIZATION.

(1) If the autotune system is found to be out of synchronism, the following procedure should be used to restore it:

(2) Determine which units are not in synchronism with the multi-turn unit by use of the foregoing procedure. No adjustment is possible on the multi-turn unit, therefore all other units should be synchronized with this unit.

(3) Repeat steps 4b(4), and (5) above.

(4) If it has been found by means of the synchronization check that autotune unit "A" is not synchronized with autotune unit "B," it may be synchronized as follows:

(a) Turn the line shaft counterclockwise until pawl No. 5 on unit "B" just drops into its slot in the cam drum. At this point the cam drum on unit "A" should be in a position so that the setscrews in the collar below the gear are accessible. In case one of the setscrews is inaccessible, tighten the accessible setscrew with a No. 6 Bristo wrench and continue to turn the line shaft counterclockwise until the inaccessible setscrew can be reached and loosened with the No. 6 Bristo wrench; after which it will be necessary to continue to turn the line shaft in a counterclockwise direction until pawl No. 5 on unit "B" again just drops into its slot in the cam drum. When this point is reached, the remaining setscrew in the collar on the

cam drum shaft in unit "A" should be loosened. In case the above conditions cannot be met, it will be necessary to choose some other pawl that will allow these conditions.

(b) The cam drum in unit "A" is now free to be turned with the fingers until No. 5 pawl just drops into its slot in the cam drum.

(c) Insert a 0.005-inch feeler gage between the cam drum washer, which is adjacent to the cam drum and the gear on the cam drum shaft in unit "A." Now insert a No. 6 wrench in the accessible setscrew, and force the collar tight against the gear and around clockwise so that all play is taken up before tightening the screw. Care must be used not to move the cam drum during this step.

(d) Turn the line shaft counterclockwise noting the sequence in which the pawls on unit "A" fall with respect to the corresponding pawls on unit "B." If all the corresponding pawls on the two units fall within one-quarter turn of the line shaft, the two units are synchronized. The second setscrew in the collar on unit "A" cam drum shaft should now be tightened.

(5) It is entirely possible, due to slight irregularities in the structure of the cam drums, that one or more corresponding pairs of pawls on the two units will not fall within the prescribed one-quarter turn tolerance or the synchronizing was not done with sufficient care, causing even No. 5 pawl on unit "A" to drop ahead or behind No. 5 pawl on unit "B" more than one-quarter turn.

(a) If it is found necessary to correct the synchronization, turn the line shaft counterclockwise, noting the sequence in which the pawls fall. If some or all of the corresponding pawls fall farther apart from each other than the prescribed tolerance, pick out the pair that drops farthest apart and note which pawl drops first.

(b) If the pawl on unit "A" drops first, note what part of a revolution the line shaft must be turned through before the corresponding pawl on unit "B" falls. Continue to crank the line shaft counterclockwise until the two setscrews on the collar below the cam drum on unit "A" are easily accessible. After loosening the setscrews, turn the line shaft counterclockwise through the required part of a turn deemed necessary to correct the error and tighten the setscrews. Repeat with more care if the pawls upon rechecking do not yet fall within the prescribed limits.

(c) If the pawl on unit "B" drops first, note what part of a revolution the line shaft must be turned through before the corresponding pawl on unit "A" falls. Continue to crank the line shaft counterclockwise until the two setscrews on the collar below the cam drum on unit "A" are easily accessible. After loosening the setscrews, rest the hand on the frame of unit "A" and, placing the thumb firmly on the cam drum, rotate the cam drum slightly counterclockwise by the amount judged necessary to correct the error, then tighten the setscrews. Repeat with more care if

the pawls upon rechecking do not yet fall within the prescribed limits.

(d) Check to make sure that both setscrews in the collar on unit "A" cam drum shaft are tight.

(6) If it has been found by means of the synchronization check that autotune unit "D," "C," or "E" is not synchronized with unit "A" causing corresponding pawls on units "A," "D," "C," and "E" to drop more than one-quarter turn of the line shaft apart, it will be necessary to resynchronize the unit or units with unit "A" which are not within the one-quarter turn tolerance by the same procedure given for synchronizing unit "A" with unit "B" as outlined in steps (4) and (5) above.

(7) It should be noted that when the autotune system has been synchronized correctly, corresponding pawls on units "A" and "B" drop within one-quarter turn of each other and the corresponding pawls on units "C," "D," and "E" drop within one-quarter turn of those on unit "A."

d. AUTOTUNE POSITIONING MECHANISM.

(1) The autotune positioning control mechanism consists of autotune seeking switch S109, which is of the open segment type, driven by an arm attached to the shaft of the cam drum on the single-turn autotune unit "A" and CHANNEL selector switch S108.

(2) The seeking switch driving arm must be so adjusted that when, for instance, position No. 5 is selected by CHANNEL selector switch S108, the No. 5 pawl will drop on all autotune units and be in this position at the end of the autotune cycle. In addition, the driving arm pin must engage the driven arm completely, but the pin must not touch the frame of seeking switch S109 at any point of the 360-degree rotation. Finally, a "backup" distance of roughly from $5/64'' \pm 1/64''$ must be maintained between the pin of the driving arm and its place of contact on the driven arm, after the cam drum to which the driving arm is attached is rotated by hand clockwise as far as it will go.

(3) If there is reason to believe that the seeking switch driving arm is out of adjustment, the following procedure should be followed to check it:

(a) Turn CHANNEL selector switch S108 to any position.

(b) Turn EMISSION selector switch S110 to the VOICE position. If the autotune motor starts running, allow it to run until the autotune cycle is complete and the motor stops.

Note

If the motor continues to run more than 30 seconds without coming to a stop, observe whether, due to misalignment of the seeking switch driving arm, seeking switch S109 is not being driven before turning EMISSION selector switch S110 to the OFF position. If the adjustment of the seeking switch driving arm appears to be correct, the trouble is probably misalignment of or foreign matter in

motor control relay K101 or limit switch S111 and S112. A short in the seeking switch itself can cause this trouble as can a short in the wiring.

(c) Turn EMISSION selector switch S110 to the OFF position.

(d) Connect a continuity checker from the number 1 contact of remote cable jack J106 to the ground connector on the transmitter. Operate LOCAL-REMOTE switch S107 to the REMOTE position.

(e) Repeat steps in paragraph 4b(2) to (4) this section, inclusive.

(f) Continue to rotate the crank slowly until the last pawl corresponding to the contact selected has just dropped into its cam slot.

(g) Note the position of the crank arm by marking a line on the casting and then slowly turn the crank until the continuity is broken.

(h) Observe the fraction of a revolution that the crank has turned. It should be within the limits of one-eighth to one full turn of the crank.

(i) If the continuity is not broken within the limits of one-eighth to one full turn of the crank, the seeking switch driving arm must be adjusted.

(j) Repeat steps (f), (g), and (h) for each contact of remote cable jack J106 up to and including number 11.

(4) If it is determined in checking the driving arm of seeking switch S109, (see par. 4d(3) this section, that it is out of adjustment, it may be readjusted as follows:

(a) If the switch shaft is not centered exactly with the cam drum shaft in front of it or if the mounting screws are loose, correct these conditions by recentering the switch shaft and tightening the screws.

(b) Select a position, by turning the line shaft crank counterclockwise, that will place the setscrews in the hub of the seeking switch driving arm in an accessible position.

(c) Loosen the setscrews with a No. 6 Bristow wrench.

(d) Turn the seeking switch driving arm clockwise if the switch, as checked in paragraph 4d(3) this section, opened early, and counterclockwise if it opened late. The amount to turn the arm must be determined by trial and error, but will be very slight unless it has become loose enough to cause an entirely different pawl number to drop on the autotune units.

(e) Tighten the setscrews, taking care that the pin completely engages the driven arm but does not come so close to the frame of the seeking switch as to permit it to touch at any point of the 360-degree rotation.

(f) Recheck as outlined in paragraph 4d(3) this section, and repeat procedure until autotune seeking switch S109 is correctly adjusted.

e. CHECKING AND ADJUSTING LIMIT SWITCHES.

(1) The limit switch is composed of a front section (S112) and a rear section (S111) and is located on the right side of the multiturn or "B" autotune unit.

(2) Rear limit switch section S111 should be adjusted so that it snaps between the limits of 3-1/4 to 9-1/4 turns of the line shaft crank counting clockwise from the time the switch snaps until the collar pin on the switch operating arm is engaged by the rear lead screw collar.

(3) Add or remove shims from the rear end of front switch section S112 insulator stack until the foregoing conditions in previous paragraph can be met.

Note

Do not attempt to bend the arms of the rear switch sections as such a procedure may destroy the snap action of the switch.

(4) The front limit switch section should be adjusted so that it closes between the limits of 3-1/4 to 9-1/4 turns of the line shaft crank counting clockwise from the point, arrived at by turning the line shaft crank counterclockwise, which the collar pin on the switch operating arm is engaged by the front lead screw collar. A continuity checker connected across the switch contacts will facilitate noting the exact moment the switch makes the contact.

(5) The main arm of the front switch section should follow the short arm for slightly less than 1/32 inch as the short arm is bent back until contact is

broken. This assures adequate contact pressure necessary for reliable operation of the switch.

(6) Using an ordinary telephone relay spring bender, bend the head of the long switch contact arm and the heel end of the short contact leaf until the foregoing conditions (steps (2) to (4) above) are met.

(7) Make sure the leaves of the front and rear switch sections are in the clear and are not in danger of shorting on any part of the mechanism.

f. REPLACEABLE PARTS OF AUTOTUNE MECHANISM.—When a failure occurs in any one or more of the five autotune units, the complete unit (as illustrated in figs. 4-15 through 4-18) should be replaced. Although one multiturn unit and four singleturn units are used, the singleturn units are not interchangeable.

(1) No attempt should be made to replace internal parts of an autotune unit (with exception of limit switches S111 and S112 on multiturn unit "B"). The adjustments required to secure proper clearances, tensions, and alignment of the internal parts of a unit can only be performed with the aid of special fixtures and test equipment that are not available in the field. Therefore, only complete autotune units are supplied in the spare parts for this equipment.

(2) Other parts of the autotune system such as motor, main or multiturn line shaft assemblies, line shaft bearings, control knobs, and limit switches, are replaceable. These replacement parts are shown in table 5-7 together with all of the complete singleturn and multiturn autotune units. Identification of parts

TABLE 5-7. REPLACEABLE AUTOTUNE PARTS

Symbol Designation	Quan.	Part Description	Used With	Stewart-Warner Part No.	W. A. Sheaffer Pen Co. Part No.
E117	1	Multiturn Autotune Unit "B"	—	564090	—
E118	1	Singleturn Autotune Unit "A"	—	564080	—
E120	1	Singleturn Autotune Unit "C"	—	564060	—
E119	1	Singleturn Autotune Unit "D"	—	564070	—
E121	1	Singleturn Autotune Unit "E"	—	564050	—
E139	1	Dial Knob for Unit "A"	E118	—	1069B-2
E140	1	Dial Knob for Unit "B"	E117	—	X-5524
E141	1	Dial Knob for Unit "C"	E120	—	1072B-2
E142	1	Dial Knob for Unit "D"	E119	—	X-5586
E143	1	Dial Knob for Unit "E"	E121	—	X-5796
O104	5	Dial Locking Bar	E139 through E143	—	X-5525
E146	5	Bar Stop Disc	E117 through E121	—	X-5620
O101	1	Main Line Shaft Assembly (Includes shaft, thrust bearings, worm gears, sprocket, and taper groove pins; parts wired together, must be assembled in the field.)	O105	565480	—
O105	1	Multiturn Line Shaft Assembly (Includes shaft, thrust bearings, worm gears, and taper groove pins; parts wired together, must be assembled in the field.)	O101	565598	—
O106	6	Line Shaft Oilite Bearing	O101, O105	564354	—
H107	1	Line Shaft Crank	O105	565090	—
E144	1	Dial—Revolution Counter for Control "B"	E117	—	X-5527
E145	1	Corrector Knob	E117	—	X-5531
O103	1	Chain Drive	O102	564276	—
O102	1	Motor Sprocket (with set screws)	O103	564895	—
S112	1	Forward Limit Switch	E117	564971	—
S111	1	Rear Limit Switch	E117	565497	—
B101	1	Motor	E117 through E121	564666	—
K101	1	Relay—Motor Reversing	B101	564532	—

may be accomplished by referring to figures 8-12 and 4-16 through 4-18.

g. REPLACING AUTOTUNE PARTS.—Since the autotune mechanism is necessarily complicated, it is recommended that only skilled and experienced personnel be permitted to repair it. The following procedures should be used to remove or replace the cover plate (front panel) and items shown as replaceable parts in the following table.

(1) REMOVING AUTOTUNE FRONT COVER PLATE.—To remove this wrap-around panel at bottom row of controls, take out eight screws along top edge, four screws at each side, and five screws on bottom of case. Pull panel forward to clear control knobs.

(2) REPLACING MOTOR.—Remove three mounting screws and unsolder wires to four motor terminals. Pivot motor as it is lifted out so as to free it from chain drive.

(3) REPLACING AUTOTUNE UNIT "A".—Turn dial locking bar to unlocked position and loosen the two No. 10 Bristo setscrews in the dial. Turn dial and locking bar counterclockwise together until bar comes free. Remove both dial and locking bar. Remove the dial back plate, loosen the two long screws on the top end of the unit and the short screw on the bottom end of the unit. Lift the unit out.

(4) REPLACING AUTOTUNE UNIT "C," "D," OR "E".—Remove four screws (holding jack strip), one on each of autotune units "C," "D," and "E," and one on the end of the jack strip. Pull the strip out as far as the wires will permit. Turn locking bar on autotune unit "C," "D," or "E" to unlocked position and loosen the two No. 10 Bristo setscrews in the dial. Turn dial and locking bar counterclockwise together until bar comes free. Remove dial, remove dial back plate, loosen the two long screws on the top end of the unit, and the short screw on the bottom of the rear plate. Lift the unit out.

(5) REPLACING AUTOTUNE UNIT "B".—Remove the right end cover plate and the dial and back plate from unit "A." Next remove the No. 10 nut on the back end of the main tuning slug lead screw which is attached to the multiplier slug coupling yoke. Then remove the two mounting screws along the upper edge of the backplate of the multi-turn unit; also remove the single screw along the lower edge. Remove the two screws which hold the limit switch and carefully pull the switch away from the assembly. Carefully pull the assembly out of the casting being very careful not to damage the tuning slug on the lead screw. If the lead screw is turned even slightly the high frequency oscillator must be recalibrated and realigned.

(6) SERVICING PARTS OF MAIN LINE SHAFT ASSEMBLY.—The following parts are associated with the main line shaft assembly:

- Main line shaft
- Singleturn worm (4 required)

- Main line shaft thrust bearing
- Line shaft bearing (4 required)
- Chain drive
- Line shaft sprocket

(a) In order to replace these parts it will be necessary to remove the entire line shaft assembly. Replacement of the entire assembly is recommended since the installation of an individual worm gear, sprocket, or line shaft entails a difficult drilling operation that is avoided when the entire assembly is replaced. Note that worm gears, sprocket, and bearing are held to the shaft by means of taper groove pins which cannot be used again if removed. The hub on each worm gear as well as the sprocket and thrust bearing would normally have to be drilled after the part was properly located on the shaft. Individual drilling of each worm gear makes these parts non-interchangeable. Thus it is obviously desirable to replace the entire assembly with pre-drilled and correctly located parts. The replacement main line shaft assembly included in the spares for this equipment, includes the above parts as well as a supply of taper groove pins to permanently assembly the parts to the shaft after installation. The worm gears, sprocket and bearing are temporarily wired to the shaft of the replacement assembly.

IMPORTANT

Since each worm gear has been pre-drilled, it is not interchangeable with like gears on the replacement assembly. For this reason it is extremely important to be sure that each worm gear is suitably identified with its particular location on the shaft before the gears are removed to install the assembly. Use following procedure to replace the main line shaft assembly.

CAUTION

When driving out the taper groove pins, in the old line shaft assembly, be very careful not to spring the line shaft.

1. Remove all singleturn autotune heads (heads "A," "C," "D," and "E").
2. Remove the taper groove pin from each of the worms and the sprocket. Before driving out a taper groove pin, be sure that the line shaft is well supported adjacent to the taper groove pin.
3. Remove the four screws from the thrust bearing retainer plate on the left end of the casting.
4. Slowly work the shaft off the left end of the casting removing each worm or the sprocket as it nears the end of the shaft.
5. Install the new line shaft assembly by reversing the above operations. Be sure each worm gear on new assembly is suitably identified with its particular location on the shaft before the retaining wire is removed so that the same gear will occupy the same position when reinstalled. Slide the gears on shaft so that sleeve end is away from thrust bearing assembly.

6. Use new taper groove pins supplied with replacement assembly to secure worm gears, sprocket, and thrust bearing to shaft. Use $1/16'' \times 3/8''$ pins for worm gears and bearings, and use $5/64'' \times 1/2''$ pin for sprocket.

Note

Be very careful not to spring the shaft when installing taper groove pins. Before driving in the pin, be sure shaft is well supported adjacent to the point where pin is being installed.

(7) REPLACING CHAIN DRIVE.—To replace the chain drive, the entire line shaft assembly must be removed. The procedure given in previous section for removal and reinstallation of line shaft should be used with the exception that the line shaft assembly need not be replaced. Be sure to use new taper groove pins when reinstalling the line shaft assembly.

(8) REPLACING LINE SHAFT BEARING.—The Oilite type line shaft bearings are held in place by means of a press fit. A steel sleeve fits over these bearings. After removing the line shaft assembly, the defective bearing should be driven out gently by using a mallet and a rod or blunt end punch. The new bearing can then be gently driven into position being careful not to deform it.

(9) REPLACING THRUST BEARING ON MAIN LINE SHAFT.—In replacing this bearing, it will not be necessary to remove the entire line shaft assembly. The following procedure is recommended:

(a) Remove the four screws from the bearing retainer plate on the left end of casting.

(b) Remove the taper groove pin from the line shaft sprocket.

(c) Work the shaft end bearing out about an inch or more from the end of the casting.

(d) Carefully block up the outside bearing collar and drive out the taper groove pin from the inside bearing collar.

CAUTION

Be careful not to spring the line shaft when driving the taper groove pin out.

(e) Replace the inside collar on the shaft, slide the new bearings on the shaft and then slide the outside collar through the bearing into the inside collar. Insert a taper groove pin and gently drive it home.

CAUTION

Be sure the outside collar is blocked up properly so that the line shaft will not be sprung.

(f) Slide the shaft back to its original position and replace the bearing plate. Use a new taper groove pin in the line shaft sprocket.

(10) SERVICING THE MULTITURN LINE SHAFT ASSEMBLY.

(a) The following parts are associated with the multiturn line shaft assembly:

Small multiturn worm
Large multiturn worm
Multiturn line shaft
Multiturn line shaft thrust bearings
Line shaft bearing (Oilite).

A complete replacement assembly including all these parts (except the Oilite bearing) is provided in the spare parts for the equipment.

(b) This shaft assembly may be serviced in the same general way as the main line shaft. The multiturn head must be removed before any work may be done on the shaft. The large worm requires a $5/64'' \times 1/2''$ taper groove pin and the small worm and thrust bearing require $1/16'' \times 3/8''$ taper groove pins.

5. ALIGNMENT OF VFO RADIO FREQUENCY CIRCUITS MODEL AN/ART-13A

a. LOW-FREQUENCY OSCILLATOR ALIGNMENT.—If low-frequency oscillator circuit components have been damaged or replaced, the grid circuit may require realignment. For realignment of the circuit, the following procedure should be followed:

(1) Operate control "F" to position 3 (415 Kc to 600 Kc). See figure 8-25.

(2) Rotate CHANNEL selector switch S108 to the L. FREQ. position.

(3) Operate EMISSION selector switch S110 to the VOICE position.

(4) When the autotune cycle has been completed, check the position of control "A." The control should stop in position 13. If the control stops in any position

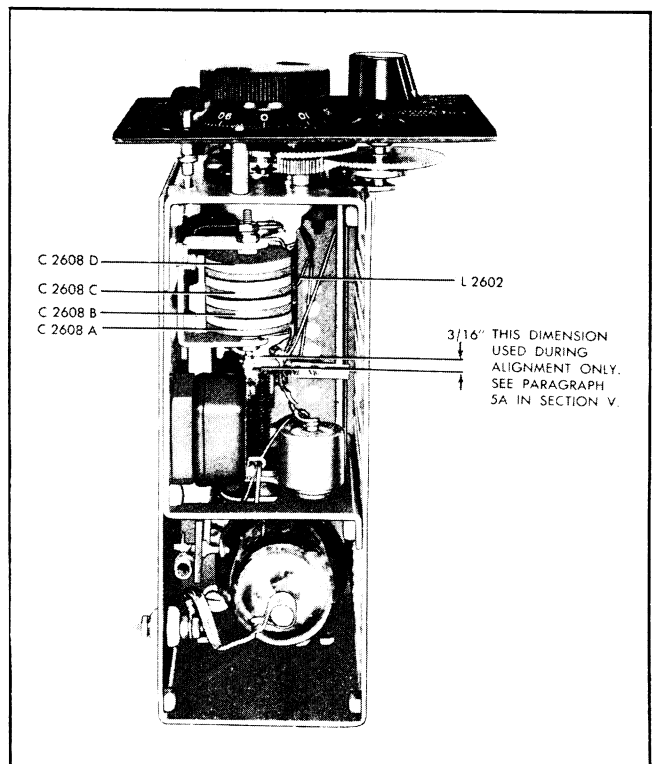

Figure 5-7. Low Frequency Oscillator

other than number 13, loosen the locking bar and manually operate control "A" to position 13.

(5) Remove cover on top of L.F.O. unit by taking out screws around rim.

(6) Turn control "G" counterclockwise until revolution counter dial reads zero and control "G" will not turn any further. Operate corrector knob so that index line is directly above the center of control "G" even though it no longer points to zero line on the control.

(7) Measure the length of tuning slug that extends out of the rear end of inductor L2602. This dimension should be 3/16" (see dimension shown in figure 5-7). If the slug extends out by this amount, no change in slug position is required and the following steps No. 8, 9, and 10 may be omitted—proceed with step No. 11. If the slug is incorrectly set, proceed with step No. 8.

(8) Examine dial drive mechanism and note small spur gear on same shaft that passes through panel from control knob "G." (This gear is labelled 02602 in figure 8-4.) Loosen two Bristo setscrews that hold this spur gear to main shaft.

(9) Hold gear train in dial drive mechanism, so that it cannot rotate. Then rotate control "G" until tuning slug in inductor L2602 extends 3/16" out of the rear of the coil form (see dimensions shown in figure 5-7).

(10) Retighten Bristo setscrews in small spur gear.

(11) Loosen two setscrews in control knob "G" and holding the gear train stationary, set knob so that zero mark lines up with the index line. Then retighten setscrews in the knob.

(12) Set control "G" to read exactly 1964.0 (this is dial setting shown in calibration table 6-9 for frequency of 600 Kc). Approach setting in a clockwise direction.

(13) Replace shield cover on top of low frequency oscillator unit. Operate power level switch to CALIBRATE position.

WARNING

Dynamotor is now operating and there is 1150 volts on caps at tops of tubes V104, V105, and V106. Extreme caution should be exercised to avoid contact with these points during remainder of alignment procedure.

(14) Connect headphones to sidetone output jack.

(15) While listening to sidetone output, adjust trimmer condenser C2608A (see fig. 5-7 and note that trimmer can be reached through slot in shield cover of LFO unit). Until zero beat is obtained between the output of the calibration oscillator in the CFI unit. These trimmer condensers are adjusted by changing the position of the small "pronged" metal lip that projects out from the side of the rounded edge of the capacitor.

Using an insulated tool, merely push this lip to change the capacity of the condenser.

(16) The alignment of band 3 is now complete. Rotate control "F" to band 2 (285 to 415 Kc).

(17) Set control "G" to read exactly 1055.0 (this is dial setting shown in calibration table 6-9 for frequency 350 Kc). Approach setting in a clockwise direction.

(18) While listening to sidetone output (in headphones), adjust capacitor C2608B (see fig. 5-7) until "zero beat" is obtained between output of low frequency oscillator and calibration oscillator in CFI unit.

(19) The alignment of band 2 is now complete. Rotate control "F" to band 1 (200 to 285 Kc).

(20) Set control "G" to read exactly 1216.8 (this is dial setting shown in calibration table 6-9 for frequency of 250 Kc). Approach setting in a clockwise direction.

(21) Listen to sidetone output and obtain "zero beat" by adjusting either or both trimmer capacitors C2608C and C2608D (see fig. 5-7).

(22) Alignment of band 1 is now complete. Check excitation over entire range on all three bands by rotating control "G" through 20 revolutions and observing P.A. GRID reading. The excitation should be nearly uniform over entire frequency range and P.A. GRID meter should read between 90 and 120.

b. HIGH-FREQUENCY OSCILLATOR ALIGNMENT (USING CFI).

(1) If the high-frequency R-F circuits are to be realigned in the field, where no frequency measuring equipment is available, the calibration oscillator may be used to check the band end-point frequencies. However, if coils, transformer, cores, capacitors, etc., in the oscillator circuit require replacement, an accurate means of measuring frequency must be used together with a portable wave meter to check the harmonic output of the frequency multiplier.

(2) For realignment when a frequency standard is not available, the following procedure should be followed:

(a) With EMISSION selector switch S110 in the OFF position, remove the cover plate from the right-hand end of the transmitter cabinet. Remove the small plate *on the bottom* of the oscillator casting. This plate covers the holes provided for the adjustment of trimmer capacitors C134 and C135. H-F oscillator grid trimmer capacitors C134 and C135, H-F oscillator grid inductor L101 tuning slug adjustment, and frequency multiplier plate inductor L105 and L106 tuning slug adjustments are thus exposed.

(b) Rotate CHANNEL selector switch S108 to the MANUAL position.

(c) Operate EMISSION selector switch S110 to the VOICE position.

(d) When the autotune cycle has been completed, operate control "A" to position 2.

(e) Set the indicator mark over control "B" to midscale, using the CORRECTOR knob.

(f) Refer to table 6-10 and obtain the dial setting of control "B" for output on 2400 Kc with control "A" in position 2. (Oscillator output on 1200 Kc.)

(g) Rotate control "B" to the setting obtained from the table. Approach the setting in a clockwise direction.

(h) Loosen the nut on the rear of the lead screw that holds the multiplier tuning slug yoke to the screw.

(i) Connect earphones to SIDETONE output jack J104.

(j) Operate power level switch S106 to the CALIBRATE position, (applies 1150 volts d.c. to plates of V104, V105, and V106).

(k) While listening to the SIDETONE output in the earphones, and keeping control "B" set at the position obtained from the table, adjust the position of the H-F oscillator grid inductor tuning slug by rotating the tuning slug screw with pliers, the jaws of which are padded to prevent marring the shaft, until zero beat is obtained between the output of the calibration oscillator and the output of the high-frequency oscillator.

Note

Caution should be exercised in adjustment of the position of the tuning slug when no frequency standard is available. A fraction of a revolution in one direction or the other should realign the circuit.

(l) When zero beat has been obtained, carefully tighten the nut on the end of the slug screw to prevent further displacement of the tuning slug.

(m) Refer to table 6-10, and obtain the correct position of control "B" for output on 3000 Kc with control "A" in position 2. (Oscillator output on 1500 Kc.)

(n) Rotate control "B" to the setting obtained from the table. Approach the setting in a clockwise direction.

(o) Adjust trimming capacitor C134 (fig. 5-8) until zero beat is obtained between the output of the H-F oscillator and the output of the calibration oscillator.

(p) Check several points in the band by obtaining control "B" settings from table 6-10 and listening to the beat note output of the SIDETONE amplifier.

(q) If the setting of control "B" necessary to obtain exact zero beat, deviates more than 4 or 5 dial divisions from the setting given in the calibration table, repeat steps 5b(2)(f) through (p), preceding, until the dial settings necessary to obtain a given frequency correspond very closely to those given in the calibration table.

(r) When alignment adjustments have been completed with control "A" in position 2, operate the control to position 1. Refer to table 6-10 opposite 2000 Kc (control "A" in position 1) and obtain the

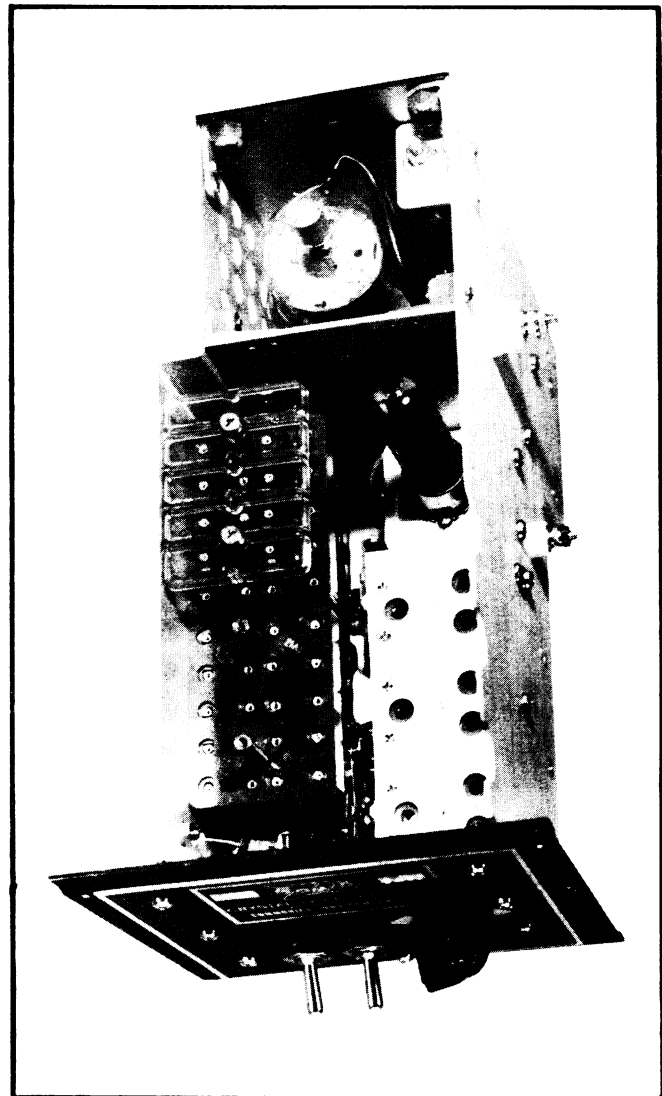

Figure 5-7A.

Crystal Controlled Oscillator Unit (CDA-T) — Top View

dial setting for Control "B." (Oscillator output on 1000 Kc.)

(s) While listening to the SIDETONE output adjust trimming capacitor C135 (fig. 5-8) until zero beat between the high-frequency oscillator output and the calibration oscillator output is obtained.

Note

Do not make any further adjustments of trimmer C134.

(t) Check several points within the frequency range of 2000 Kc to 2400 Kc by obtaining the dial setting of Control "B" from the table, listening to the SIDETONE output, and operating Control "B" about the setting obtained from the calibration table. The settings should check with those given in the table within 4 or 5 dial divisions.

Note

No adjustment of the high-frequency oscillator grid inductor slug should be made with Control "A" in position 1.

(u) Return EMISSION selector switch S110 to the OFF position.

c. HIGH-FREQUENCY OSCILLATOR ALIGNMENT (USING EXTERNAL FREQUENCY STANDARD).—If oscillator circuit components have been replaced and an accurate frequency standard is available, the following procedure should be used for the alignment of the high-frequency oscillator circuit.

(1) With EMISSION selector switch S110 in the OFF position, remove the cover plates from the right-hand end and bottom of the transmitter cabinet. H-F oscillator grid trimmer capacitors C134 and C135, H-F oscillator grid inductor L101 tuning slug adjustment, frequency multiplier plate inductors L105 and L106 tuning slug adjustments are exposed.

(2) Rotate CHANNEL selector switch S108 to the MANUAL position.

(3) Operate EMISSION selector switch S110 to the VOICE position.

(4) When the autotune cycle has been completed, operate Control "A" to position 2.

(5) Set the indicator mark over Control "B" to midscale, using the CORRECTOR knob.

(6) Refer to table 6-10 and obtain the dial setting for an output frequency of 2400 Kc with Control "A" in position 2. (Oscillator output on 1200 Kc.)

(7) Rotate Control "B" to the setting obtained from the table.

(8) Loosen the nut on the rear of the lead screw that holds the multiplier tuning slug yoke to the screw.

(9) Operate power level switch S106 to the CALIBRATE position.

(10) Measure the output frequency of the oscillator and adjust the position of the tuning slug in L101 until the oscillator is exactly 1200 Kc.

(11) When the correct position of the tuning slug has been found, tighten the locking nut to prevent any further displacement of the slug.

(12) Refer to table 6-10 and obtain the setting of Control "B" necessary to obtain an output frequency of 3000 Kc with Control "A" in position 2. (Oscillator output on 1500 Kc.)

(13) Rotate Control "B" to the setting obtained from the table.

(14) Measure the output frequency of the oscillator and adjust capacitor trimmer C134 (fig. 5-8) until the frequency of the oscillator output is exactly 1500 Kc.

(16) Check several points within the band by obtaining dial settings from the calibration tables, rotat-

ing Control "B" to these settings and measuring the frequencies.

Note

Always keep in mind that with Control "A" in positions 1 or 2, the frequencies given in the calibration tables are always twice the output frequency of the oscillator. With the power level switch in the CALIBRATE position only, the oscillator is operating; therefore the output frequency to be measured will always be one-half the frequency that is given in the calibration tables.

(16) If the dial setting of Control "B" necessary to obtain output on a selected frequency, deviates more than 4 or 5 dial divisions from the dial setting given in the calibration tables, repeat steps (6) through (15) until the actual dial setting of Control "B" necessary to obtain a given output frequency, corresponds very closely to the setting given in the table.

(17) When alignment has been completed with Control "A" in position 2, operate the control to position 1.

(18) Refer to table 6-10 and obtain the dial setting of Control "B" to obtain an output frequency of 2000 Kc with Control "A" in position 1. (Oscillator output on 1000 Kc.)

(19) Adjust trimming capacitor C135 (fig. 5-8) until the oscillator output frequency is exactly 1000 Kc.

Note

Do not make any adjustment of C134 or the core in inductor L101 with Control "A" in position 1.

(20) Check several points within the band by comparing the actual dial settings necessary to obtain a given frequency with the dial settings given in the calibration tables for the same frequency. The settings should check within four or five dial divisions.

(21) Return EMISSION selector switch S110 to the OFF position.

d. FREQUENCY MULTIPLIER ALIGNMENT.—Having completed the alignment of the high-frequency oscillator circuit, complete the R-F circuit alignment by following the procedure outlined below for adjustment of the frequency multiplier circuits.

(1) With the transmitter tipped up on the rear edge and the bottom cover removed, the frequency multiplier plate tank capacitors are exposed. The multiplier plate tank capacitors are located beneath the multiplier chassis (stacks of ceramic capacitor sections.) Capacitor section A of each capacitor (C111 and C115) is located nearest the right-hand side of the transmitter, as the transmitter is viewed from the bottom, with sections B, C, D, E, and F, in order in the stack. See figure 5-9.

(2) Operate Control "A" to position 6.

(3) Rotate meter selector switch S105 to the P.A. GRID position.

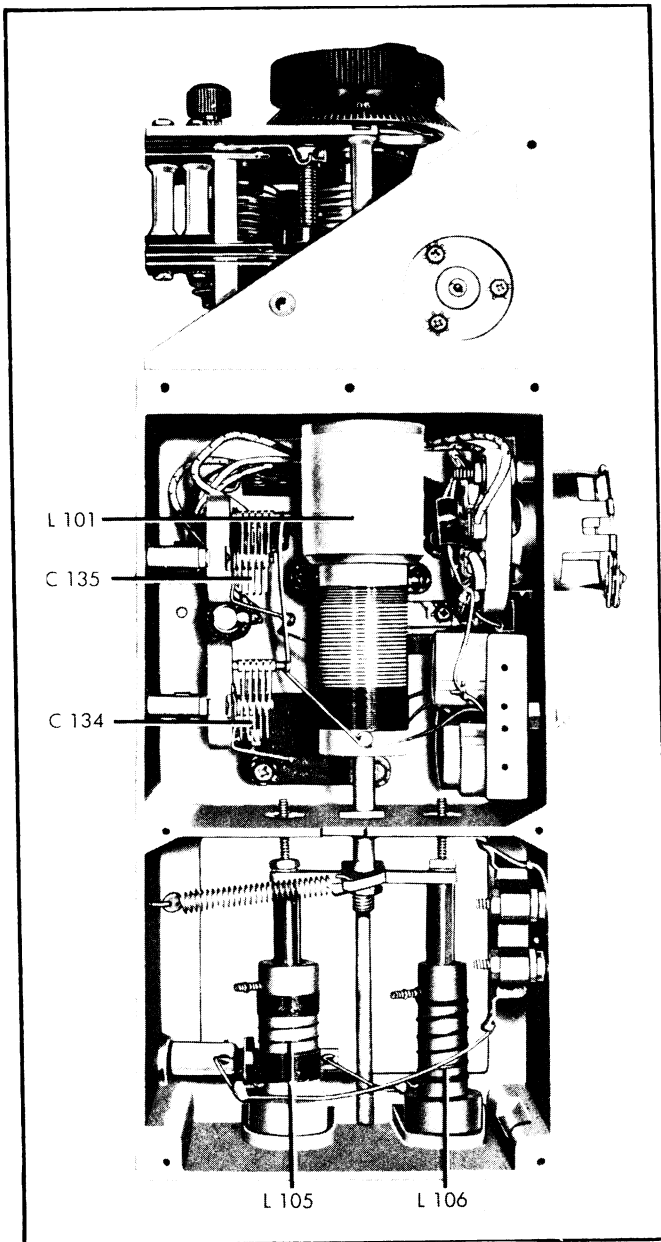

Figure 5-8. High Frequency Oscillator
— Side View, Open

(4) Rotate Control "B" until the dial reading is 1100.

(5) Operate the power level switch to the TUNE position.

(6) Operate EMISSION selector switch S110 to the CW position. (Applies 1150 volts d.c. plate potential.)

WARNING

Use an insulated tool to adjust the capacitors. When the key is operated, the capacitor is at a potential of 400 volts above ground.

(7) Insert a shorted plug in KEY jack J103 and adjust section F (bottom of stack) of first multiplier

padding capacitor C111 to the position that will give the maximum P.A. GRID meter reading on M102.

Note

To vary the capacity of sections of C111 or C115, rotate the metal lip that protrudes between capacitor sections.

(8) Using a portable wavemeter check the output frequency of the first frequency multiplier stage to be sure that the plate circuit is tuned to the correct harmonic. The output should be on approximately 5478 Kc with Control "A" in position 6 and Control "B" tuned to a dial reading of 1100.

(9) When it has been ascertained that the multiplier output is on the correct harmonic, rotate Control "B" over the entire range and observe the meter reading for P.A. GRID.

WARNING

When the key is operated, inductors L105 and L106 are at a potential of 400 volts above ground.

(10) Take out dips in the meter reading by adjusting section F of first multiplier padding capacitor C111 for an average reading of the meter.

(11) A drop at the extreme ends of the range is permissible, but if the meter needle still dips sharply at any other point, rotate Control "B" to a dial reading of 1100, loosen first multiplier inductance L105 tuning slug locking nut, and change slightly the position of the tuning slug. Tighten the slug locking nut.

(12) Rotate Control "B" over the entire range and check the P.A. GRID current. Meter M102 should indicate a consistent value of grid current over the entire range. If the meter needle dips sharply at any point repeat steps (10) and (11).

(13) Having completed the adjustment of the inductor slug and section F of C111, remove the key shorting plug and rotate Control "A" to position 5.

(14) Rotate Control "B" to a dial reading of 1100.

(15) Replace the key shorting plug, adjust section E of capacitor C111 to give a maximum P.A. GRID meter reading and check with a wavemeter for the current harmonic.

Note

Do not make any further adjustments of the tuning slug in L105.

(16) Rotate Control "B" through the entire range and check the excitation. If dips occur in the meter reading readjust padding capacitor C111E.

(17) Remove the key shorting plug and operate Control "A" to position 4.

(18) Replace the key shorting plug and adjust section "D" of C111 for maximum P.A. GRID meter reading.

(19) Check the excitation over the band by operating Control "B" over the entire range. If dips in the meter reading occur readjust C111D.

(20) Repeat steps (18) and (19) for positions 3, 2, and 1 of Control "A." Adjust capacitor sections C, B, and A for Control "A" positions 3, 2, and 1 respectively.

(21) Having completed the alignment of the first frequency multiplier stage, remove the key shorting plug and operate Control "A" to position 12.

(22) Rotate Control "B" to a dial reading of 1100.

(23) Replace the key shorting plug and adjust section F of second multiplier padding capacitor C115 for maximum P.A. GRID meter reading.

(24) Using an insulated screw driver to reduce body capacity, adjust trimmer capacitor C136 for maximum P.A. GRID meter reading.

(25) Check the output frequency of the second multiplier with a wavemeter. With Control "A" in position 12, and Control "B" tuned to a dial reading of 1100, the wavemeter should indicate approximately 16,434 Kc. A materially different reading indicates that a wrong harmonic has been chosen, necessitating a readjustment of padding capacitor C115F and trimmer capacitor C136.

(26) Take out dips in the meter reading by adjusting section F of padding capacitor C115.

(27) A drop at the extreme ends of the range is permissible, but if the meter needle still dips sharply at any other point, rotate Control "B" to a dial reading of 1100, loosen second multiplier inductance L106 tuning slug locking nut, and change the position of the tuning slug slightly. Tighten the slug locking nut.

(28) Again rotate Control "B" over the entire range and check the excitation. If the meter dips sharply at any point repeat steps (24) through (28).

(29) Having completed the adjustment of the inductor slug and section F or C115, remove the key shorting plug and rotate Control "A" to position 11.

(30) Rotate Control "B" to a dial reading of 1100.

(31) Replace the key shorting plug, adjust section E of capacitor C115 to the position which gives the maximum P.A. GRID meter reading, and check with a wavemeter for the correct harmonic.

Note

Do not make any further adjustment of the tuning slug in L106 or trimmer capacitor C136.

(32) Rotate Control "B" through the entire range and check the excitation. If dips occur in the meter reading readjust padding capacitor C115E.

(33) Repeat steps (30), (31) and (32) with Control "A" in positions 10, 9, 8, and 7. Adjust capacitor sections D, C, B, and A for Control "A" position, 10, 9, 8, and 7 respectively.

The above procedure completes the alignment of the high-frequency R-F circuits of the transmitter.

6. ALIGNMENT OF CRYSTAL-CONTROLLED RADIO FREQUENCY CIRCUITS—MODEL AN/ART-13B

a. LOW-FREQUENCY OSCILLATOR ALIGNMENT.—When using the CDA-T Crystal Oscillator Unit, no R-F alignment is necessary, as the crystals and the circuit in which they are used will maintain the transmitter output at the proper frequency. The only adjustment in this low frequency oscillator circuit is a variable choke (L803) which resonates the circuit to obtain maximum output at the crystal frequency. As this one choke covers all four low frequency channels, its setting will depend on the number of crystals utilized. If it is desired to operate on all four channels, the choke setting will be a compromise arrangement. If a lesser number of channels is required, the setting may be more accurately determined, resulting in an increase in grid drive to the power amplifier stage.

b. HIGH FREQUENCY OSCILLATOR ALIGNMENT.—As indicated in the previous paragraph, no R-F alignment is required in the CDA-T Crystal Oscillator unit. In its high frequency circuit, any one of twenty crystals is selected by means of the CHANNEL switch autotune system and the manually-operated "A-B" switch. The output of this crystal-controlled

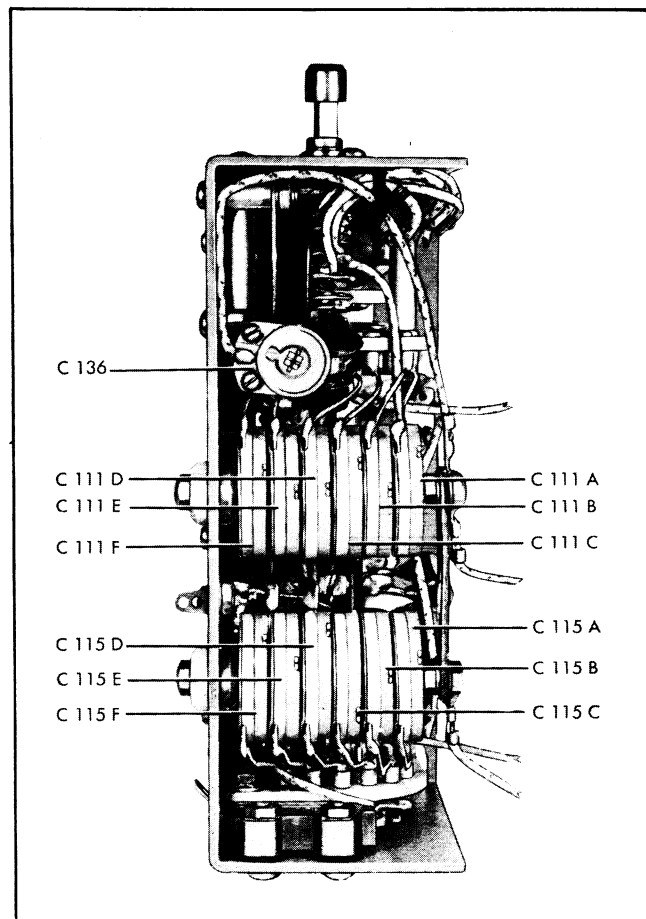

Figure 5-9. Frequency Multiplier

oscillator circuit is coupled to either the 1st Multiplier stage, or the 2nd Multiplier stage, depending on the final output frequency desired. These multiplier stages are utilized for crystal-controlled operation, exactly as previously outlined in paragraph 5 of this section for VFO operation.

7. ALIGNMENT OF CFI UNIT.

a. GENERAL CALIBRATION INSTRUCTIONS.

—Because the inductor tuning adjustment screws are in a position difficult to reach when the unit is in place in the transmitter, and because of the proximity of exposed leads and plate caps carrying potentials of more than 400 volts, a short extension cable allowing the CFI Unit to be on the bench beside the transmitter is recommended. Because of the extremely small space between crystal holder and tubes, adjustments of the unit must be made with a very small "jeweler's" type screw driver having a shank at least 1-1/4 inches long.

(1) Make sure that EMISSION selector switch S110 is in the OFF position.

(2) Insert a coin or a screw driver in the slot of the transmitter cover hold-down screws, rotate the screws one-half revolution counterclockwise and lift off the cover.

(3) Loosen the two large screws that hold the unit to the main transmitter chassis.

(4) Raise the unit until the connector plug is disengaged and lift the unit out.

(5) Connect an extension cable to CFI jack J111 in the transmitter and to unit plug P2201.

(6) Connect a Vacuum Tube-Voltmeter between oscillator control grid (pin No. 4) of tube V2201 (JAN-12SL7GT) and chassis ground. Since the bottom of socket of V2201 is not easily accessible, it will be more convenient to make connection to control grid of V2201 by partially withdrawing tube from socket and connecting to tube pin at top of socket.

(7) Turn LOCAL-REMOTE switch S107 to the LOCAL position.

(8) Rotate CHANNEL selector switch S108 to the MANUAL position.

(9) Turn EMISSION selector switch S110 to the VOICE position.

(10) When the autotune cycle has been completed, rotate Control "C" to any dial reading, taking care to approach the chosen setting by turning clockwise through at least 20 or 30 degrees of rotation and to set the dial accurately.

(11) Rotate Control "A" to position 1.

(12) Turn power level switch S106 to the CALIBRATE position. (Applies 1150 volts d.c. to plates of V104, V105, and V106.)

(13) It is now possible to make an approximate calibration or a precision calibration depending upon the instruments available to the repairman and the accuracy of some local frequency standard. No instruments (other than vacuum tube voltmeter previously mentioned) and no local frequency standard are required to make approximate calibration. The precision calibration requires the use of an Oscilloscope and an accurate standard frequency source such as a U.S. Bureau of Standards transmission or a local oscillator, that has just been accurately checked against the Bureau of Standards Transmission. The procedure for precision calibration is given in paragraph *b* that follows and the procedure for approximate calibration is given in paragraph 6c, following.

U. S. BUREAU OF STANDARDS TRANSMISSIONS.

The U.S. Bureau of Standards transmits standard frequencies from its station WWV. This primary frequency standard is available throughout the United States and in many other parts of the world. Two standard-frequency transmissions are made day and night, one throughout the night and the other throughout the day. The following schedule is maintained:

2.5 MC. from 2400 to 1400 *GMT.

5.0 MC. Continuously day and night.

10.0 MC. Continuously day and night.

15.0 MC. Continuously.

*Greenwich Mean Time

b. PRECISION CALIBRATION.—Obtain a length of stranded, insulated wire about 6 feet long. Connect both ends of the wire to the vertical deflecting plates of an oscilloscope (scope should be equipped with vertical amplifier).

(1) Extend the length of wire and twist it to form a "twisted-pair." Leave a loop at the far end of the lead so that the loop can be placed over a tube on the CFI unit.

(2) Place loop of wire over tube V2201 on CFI unit.

(3) Connect the output of a stable local 200 Kc oscillator to the horizontal deflecting plates of the oscilloscope. Local 200 Kc oscillator must have been checked recently against a U.S. Bureau of Standards transmission to insure frequency accuracy.

(4) Turn on oscilloscope.

(5) Insert a small "jeweler's" type screw driver in the slot of inductor Z2201A tuning slug adjustment screw (see fig. 5-10) adjacent to which is stamped number "200." Rotate this screw and observe reading of vacuum tube voltmeter. As 200 Kc crystal oscillator circuit approaches resonance, the meter reading will increase. It will be noted that the tuning is very broad after the meter has reached its peak reading. Final adjustment of the tuning slug position is now made by observing pattern on oscilloscope screen.

(6) Continue to adjust tuning slug in inductor Z2201A until pattern on oscilloscope forms a staple ellipse or circular shape. When this occurs, the frequency of the 200 Kc crystal oscillator in the CFI unit is identically the same as the frequency of the local oscillator which was previously set to 200 Kc and ac-

curately checked against a U.S. Bureau of Standards Transmission.

(7) Turn transmitter on and off several times, noting whether the crystal oscillates positively (vacuum tube voltmeter reading rises to peak reading) as soon as transmitter is turned on. If necessary to improve crystal starting, slightly detune Z2201A tuning slug (marked "200").

(8) Remove the "pick-up loop" of wire that is now around tube V2201 and place it around tube V2203. Output frequency of CFI unit (which must now be adjusted to 50 Kc) will be fed into oscilloscope.

(9) Set local oscillator to 50 Kc and check its accuracy against U.S. Bureau of Standards Transmission. 50 Kc output of this oscillator will now be fed to oscilloscope.

(10) Adjust tuning slugs in inductors Z2201B (marked "50"), Z2202A (marked "150"), and Z2202B (marked "50") until a stable circular or elliptical shaped figure appears on the oscilloscope screen. This will indicate that output of CFI unit has identically the same frequency as local oscillator which was previously standardized at 50 Kc. If a stable elliptical or circular figure cannot be obtained, try turning adjusting screw Z2202B three turns clockwise and turn adjusting screw Z2202A counterclockwise several turns; again try to obtain the desired figure on the oscilloscope. If the correct figure still cannot be obtained, turn adjusting screw Z2202B six turns counterclockwise and turn adjusting screw Z2202A several turns clockwise; additional fine adjustment of these two screws should make it possible to obtain correct image on oscilloscope screen. After the stable circular or elliptical figure is obtained, adjust Z2202A, Z2202B and Z2201B for maximum output (indicated by largest size of figure on oscilloscope screen).

(11) A further check of the accuracy of the 50 Kc output of the CFI can now be made as follows:—Tune high frequency oscillator Control "B" until a beat note is heard in phones connected to sidetone jack on transmitter. Carefully note exact dial reading for "zero beat." Then rotate Control "B" until next (*nearest*) beat note is heard in phones. Again note exact dial reading for zero beat. Use Calibration Tables in section VI and find the frequencies for the two dial settings that were obtained above. The two frequencies should be approximately 100 Kc apart if the CFI output is 50 Kc.

(12) Alignment of CFI unit is complete and its 50 Kc output will be quite accurate.

c. APPROXIMATE CALIBRATION.—The procedure given in paragraph 6a(1) through (13), this section, must be carried out before proceeding with the following:

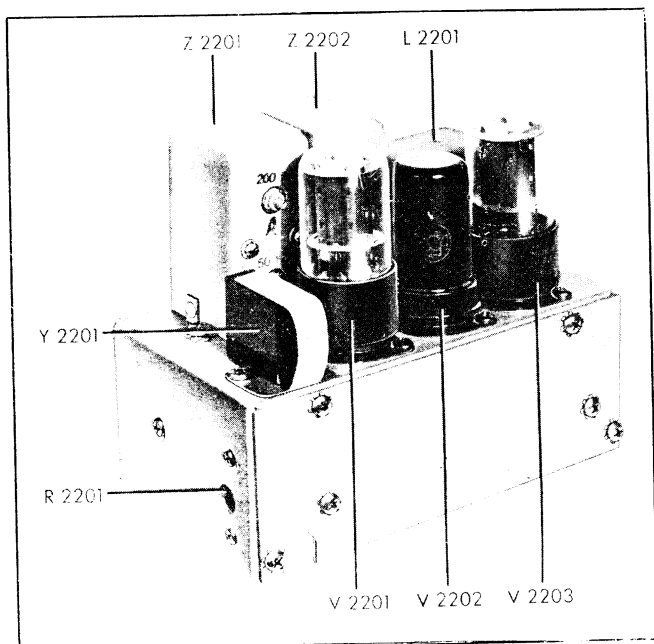

Figure 5-10. MCW-CFI Unit — Top View

(1) Connect a pair of earphones to SIDETONE jack on transmitter.

(2) Insert a small "jeweler's" type screw driver in the slot of inductor Z2201A tuning slug adjustment screw (see fig. 5-10) adjacent to which is stamped the number "200." Rotate the screw and observe the reading of the vacuum tube voltmeter. As the crystal oscillator circuit approaches resonance, the meter reading will increase. It will be noted that the tuning is very "broad" and that tuning slug for inductor Z2201A may be adjusted over a considerable range without appreciably changing the peak reading of the meter. Note the number of turns of the tuning slug that can be made without changing peak meter reading. By continuing to turn the tuning slug half this number of turns after the meter just approaches peak reading, it will be possible to set the tuning slug to the approximate center of the broad resonance peak. This adjustment must be made to set the tuning slug correctly.

(3) The peak reading obtained on the meter in the previous operation indicates maximum crystal activity and proper operation of the crystal oscillator circuit. If a loud squeaking rush noise is heard in the headphones as soon as the crystal oscillator functions, adjust tuning slug (stamped "150") in inductor Z2202A until this noise disappears.

(4) Quiet operation, arrived at by the foregoing checks and adjustments, indicates correct operation and calibration beat signals may be searched for by rotating Control "B."

(5) Tune the h-f oscillator by rotating control "B" until two approximately equal level loud signals are heard.

(6) Compare the zero beat dial settings of the two selected beat points with the calibration table check points to determine if the interval between the points is 100 Kc, (oscillator frequency is doubled on range 1 causing 50 Kc interval of CFI output to be recorded at 100 Kc).

(7) If the interval is correct and the dial readings correspond reasonably (within 25 dial divisions) with the calibration table, tune Z2201B (farthest from crystal) marked "50," tune Z2202B (nearest crystal) marked "50," and tune Z2202A (marked "150") for maximum sidetone output. Recheck tuning in the same order. If interval is less than 100 Kc, see paragraph 6c(10), this section. If interval is greater than 100 Kc, see paragraph 6c(11), this section.

(8) Recheck adjustment of Z2201A (marked "200") to determine the setting which is the midpoint of the range in which the vacuum tube voltmeter reading is a maximum.

(9) Turn the transmitter on and off several times, noting whether the crystal oscillates positively (vacuum tube voltmeter rises to peak reading) as soon as the transmitter is turned on. Detune Z2201A (marked "200") slightly to improve crystal starting if necessary.

(10) If less than a 100 Kc interval is obtained, rotate mixer tank Z2202B adjustment screw clockwise

three turns, then rotate tripler tank Z2202A adjustment screw counterclockwise until harsh noises occur and disappear. Repeat steps (4) through (7).

(11) If more than a 100 Kc interval is obtained, rotate mixer tank Z2202B adjustment screw counterclockwise three turns, then rotate tripler tank Z2202A adjustment screw clockwise until harsh noises occur and disappear. Repeat steps (4) to (7).

(12) The unit can now be considered to be aligned and the calibration frequency accurate to within very close limits. Replacement in the transmitter completes the operation.

8. ADJUSTMENT OF MCW OSCILLATOR.

a. The percentage of modulation of the r-f carrier when using MCW emission is proportional to the voltage that is developed across the resistor R2201. The percentage of modulation may be regulated by varying the resistance of R2201. The rheostat has been carefully adjusted at the factory and should not be tampered with unless it has been proven that adjustment is necessary.

b. It is recommended that a laboratory source of power be used. The following procedure is recommended for the adjustment of rheostat R2201.

(1) Remove the transmitter cabinet cover, the autotune cover plate, and the wrap-around section of the right-hand end of the transmitter cabinet.

(2) Remove the snap button from the side of the chassis of the MCW-CFI unit. (See fig. 5-10).

(3) Tune the transmitter into a phantom antenna (Antenna A-58 if available) on 2400 Kc. Load the power amplifier to exactly 100 on the P.A. PLATE meter in the transmitter when using CW transmission.

(4) Place the EMISSION selector switch on the MCW position, and, while holding the TEST switch closed, adjust resistor R2201 until the plate meter reads 190.

9. REPLACING AND ADJUSTING VACUUM CONTACT S116.

a. The Vacuum Contact S116 is mounted on the front panel of Keying Relay K102 and is operated by that relay. Replacement of the vacuum contact will become necessary in event the glass bulb is cracked, contacts are badly burned, or a leak develops at seal where movable switch arm passes through base of tube. A leak at the seal or a crack in the glass bulb will permit arcing that eventually destroys internal contacts.

b. Although the replacement of the vacuum contact is a relatively simple operation, the repairman is cautioned that proper adjustment during installation is of extreme importance if the switch is to operate at the proper time. Failure to properly adjust the sequence of the vacuum contact with contacts in keying relay may cause arcing that will immediately destroy a new vacuum contact after installation. The following replacement and adjustment procedure is recommended:

(1) Loosen the setscrews that hold the connecting wires to the fixed contact terminals (No. 3 in fig. 5-11), and remove the wire connector.

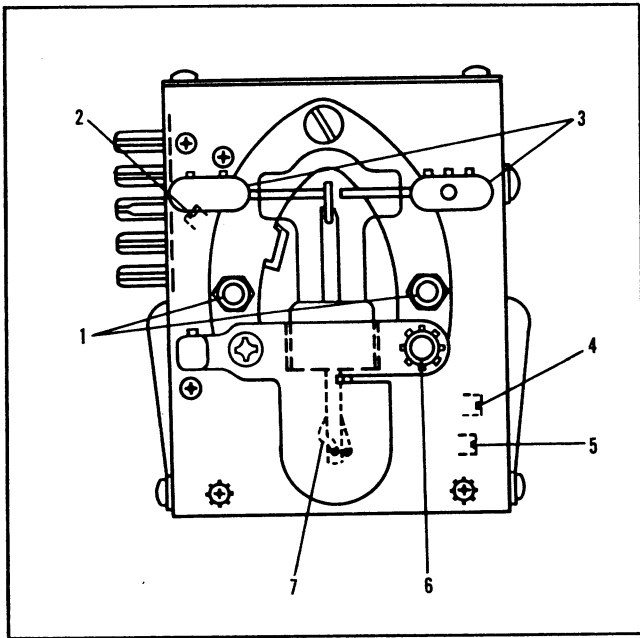

Figure 5-11. Keying Relay K102 and Vacuum Contact S116

(2) Loosen the stud (No. 6 in fig. 5-11) until the clamp around the base of the vacuum contact becomes loose enough to allow the removal of the glass vacuum tube. Remove the tube containing the switch by pulling glass tube straight up.

(3) Note the split collar on end of glass operating arm that connects vacuum contact to relay case. Loosen setscrew in this collar so that collar is loose on its shaft.

(4) Before attempting to install the new vacuum switch, note the manner in which the movable switch arm (extending out of bottom of glass bulb) engages the wire actuating arm (No. 7 in fig. 5-11). When installing the new switch, the arm of the switch must be securely engaged between the two wires that form the actuating arm (No. 7 in fig. 5-11). To prevent damage to the new switch, it is recommended that the two wires forming the actuating arm, be spread apart very slightly while the vacuum switch arm is being engaged. This may be accomplished by using a screw driver blade to spread the wires approximately $1/32$ ".

(5) Place rubber gasket in position and insert new vacuum switch in socket. Be sure movable switch arm is securely engaged in wires of operating arm No. 7.

(6) Retighten stud (No. 6 in fig. 5-11) and reconnect wires to terminals labelled No. 3 in figure 5-11.

(7) With relay in normal unoperated position, the vacuum contact (in glass bulb) should be closed and resting firmly against the fixed contact that is connected to RECEIVER terminal of transmitter. To se-

cure this adjustment, grasp split collar on operating arm and rotate slightly until switch is making desired contact; then tighten setscrew in the split collar while holding the collar here in the desired position.

(8) The timing adjustment of the vacuum contact can now be made. Remove top cover of keying relay case by taking out two Phillips screws on the top surface.

(9) Examine the interior of the relay and note double row of contacts near top. Also note that movable contact arms are all attached to a thick bakelite plate located in the center of the case. By using a thin tool, with a notch in one end, that is capable of straddling this bakelite plate, it is possible to grip the bakelite and operate the relay mechanically by pushing the plate from side to side. Note that as this bakelite plate is moved, all movable contact arms in the relay as well as the movable arm in the vacuum contact will also move.

(10) With the relay in the normal "rest position," three internal relay contacts, on the side nearest the plug, are closed and the vacuum contacts (in external glass bulb) should now be resting firmly against the fixed contact that connects to the RECEIVER terminal on the side of transmitter case.

(11) If vacuum contact is not set properly, loosen two studs (labelled No. 1 in fig. 5-11) that hold horse-shoe shaped yoke to relay case.

(12) Note adjustment screw (labelled No. 2 in fig. 5-11) that can be seen through hole on plug side of case. By rotating this screw, the position of the movable arm in the vacuum contact can be adjusted as desired.

(13) After vacuum contact has been adjusted to correct position while relay is in rest position, the relay should then be operated mechanically (as described in step No. 9) and the action of the vacuum contact and the 5 normally open contacts on the interior of the relay case should be noted.

(14) As the relay is operated mechanically, the correct sequence of contact make and break is as follows:

First: Three normally closed contacts in relay case will open.

Second: Movable arm of vacuum contact breaks connection to fixed contact that is connected to RECEIVER post on transmitter.

IMPORTANT

This contact must break *AFTER* the three normally closed contacts open up as described in first step.

Third: Movable arm of vacuum contact makes connection to opposite fixed contact that is connected to COND. post on transmitter case.

Fourth: The five normally open contacts in relay case will close.

IMPORTANT

These five contacts must close *AFTER* vacuum contact has closed as described in third step.

(15) If above sequence is not obtained, further adjustments of screw labelled No. 2, in figure 5-11 is

required. By careful adjustment of vacuum contact movable arm position, using this adjustment screw, the desired sequence can be obtained.

(16) After adjustment has been completed, re-tighten two screws labelled No. 1 in figure 5-11.

**SECTION VI
SUPPLEMENTARY DATA**

1. CALIBRATION TABLES 6-9 AND 6-10.

The calibration tables have control settings for every kilocycle. The first column, headed Freq. is the frequency column, the other columns are headed with the letter identifying the control.

a. The figures in heavy black type are crystal check points.

b. The heavy black lines divide the frequency range between crystal check points in two equal parts. Always use the check point that appears between the same heavy lines that the desired frequency does. The note at the bottom of each page will aid in locating the proper check point.

2. TABLES OF APPROXIMATE CONTROL SETTINGS (FOR ANTENNA TUNING AND LOADING)—TABLE 6-11.

These tables show approximate dial settings for the various frequencies and for various lengths of antennas. The tables are repeated to show settings for the case using the antenna shunt capacitor. The spaces marked with three dots in column D are left blank because the setting of that control cannot be determined beforehand. All settings are approximate and the procedure outlined for ADJUSTMENTS must be followed to obtain the exact settings.

a. To determine which table to use, measure the length of the antenna taking the total length of wire from the antenna terminal of the transmitter to the extreme end of the antenna. If the antenna is a "T," disregard the length of wire in the shorter branch, or, if the two branches are equal, include the length of only one of them. To check the choice of table, tune up the set on one of the frequencies given in the table for the antenna length nearest that measured above. Choose a frequency which tunes on position 7 on control C. Compare the actual settings given in this table and also in the tables for the next shorter and the next longer antenna lengths. Of these three tables the one showing control settings closest to the actual control settings is the table to use for this particular installation. Record the type of airplane and a brief description of the antenna in the three lines above that table to identify it so that table may be readily recognized as the correct one for future use on any frequency.

b. The antenna cannot be tuned at any frequencies below those shown in the tables for the various lengths of antennas.

3. GENERAL SPECIFICATIONS OF EQUIPMENT.

a. RANGE OF AVAILABLE TRANSMISSION FREQUENCIES.

VFO Low Frequency Range 200 Kc to 600 Kc.

*Crystal-Controlled Range 300 Kc to 500 Kc.

Frequencies in this range are generated in the low frequency oscillator of the CDA-T unit. Three crystal sockets are utilized, two accommodating single crystals and one a dual-type holder. The four frequencies obtainable are switched by means of a 4-position rotary switch on the CDA-T panel. Due to physical limitations of the dual type crystal holder, the two crystals used must be between 400 Kc and 500 Kc. To change transmitter frequency in this low frequency band, it is only necessary to change the crystal and switch to the proper one to four channel position. Control "A" must be set to position 13 (L.F.) and Control "C" to position 8 to obtain operation in the low frequency range.

TABLE 6-1. RANGE OF AVAILABLE TRANSMISSION FREQUENCIES IN LOW FREQUENCY RANGE.

Position of Control "F"	Frequency Range
1	200Kc to 285Kc
2	285Kc to 415Kc
3	415Kc to 600Kc

When transmission frequencies in the low frequency range are desired, control "A" must be set on position 13 (L.F.). Controls "F" and "G" on the panel of the low Frequency Oscillator Unit are then utilized to set the oscillator to the exact frequency.

VFO High Frequency Range 2000 Kc. to 18100 Kc.

*Crystal-Controlled Range 1670 Kc to 18000 Kc.

Frequencies in this range are generated in the high frequency oscillator of the CDA-T unit. 20 crystals may be utilized, each producing a separate frequency output, utilizing the regular frequency multiplier stages as outlined in VFO operation. All crystal operation in the high frequency range is selected through the autotune system, by channels 1 through 10. This switching is supplemented by a manually-operated "A-B" toggle switch, located on the CDA-T panel. No crystal-controlled operation is possible with the CHANNEL selector switch in the MANUAL position. Range of available transmission frequencies in the high frequency

*Applies only to AN/ART-13B

range are the same as listed in table 6-2 for VFO operation. The frequency of crystals to be used in these first 12 positions of control "A" is limited by the range of each control position.

TABLE 6-2. RANGE OF AVAILABLE TRANSMISSION FREQUENCIES IN HIGH FREQUENCY RANGE

Position of Control "A"	Frequency Range
1	* (1670 Kc) 2.0Mc to 2.4Mc
2	2.4Mc to 3.0Mc
3	3.0Mc to 3.6Mc
4	3.6Mc to 4.0Mc
5	4.0Mc to 4.8Mc
6	4.8Mc to 6.0Mc
7	6.0Mc to 7.2Mc
8	7.2Mc to 9.0Mc
9	9.0Mc to 10.8Mc
10	10.8Mc to 12.0Mc
11	12.0Mc to 14.4Mc
12	14.4Mc to 18.1Mc

b. FREQUENCY STABILITY.—With VFO operation, the deviation of the carrier frequency in this transmitter is less than 0.05% for a variation of 45°C in the ambient temperature. In crystal-controlled operation (Model AN/ART-13B only) frequency stability is dependent on the frequency tolerance and temperature characteristics of the crystals used.

c. ANTENNA REQUIREMENTS.

(1) HIGH FREQUENCY RANGE.—The output circuit incorporated in the Radio Transmitter T-47A/ART-13 is capable of tuning and delivering power to fixed aircraft antennas between 17 and 65 feet in length, over the frequency range 3000 Kc to 18,100 Kc, without the use of external shunt capacitors. For operation in the frequency range 1670 Kc to 3000 Kc, and when using fixed antennas shorter than 50 feet, the separate Antenna Shunt Capacitor Unit CU-24/ART-13 may also be required to properly tune and deliver power to the antenna (see par. 6b(2) (jj), section II, and table contained therein). The antenna tuning and loading circuits in the transmitter are also capable of accommodating a 200 ft. trailing wire type of aircraft antenna. Trailing wire operation will increase the range of the equipment considerably in the 1670 Kc to 6000 Kc frequency range; small improvement will be noted in the 6000 Kc to 10,000 Kc range. No appreciable increase in range is indicated when using a trailing wire antenna for frequencies above 10,000 Kc.

(2) LOW FREQUENCY RANGE.—When the transmitter is operated in the frequency range 200 Kc to 600 Kc, Antenna Loading Unit CU-32/ART-13A must be used to tune and deliver power to either fixed aircraft antennas (from 30 to 65 ft. long) or a trailing wire antenna (approximately 200 ft. long).

d. R-F POWER OUTPUT.

(1) Table 6-3 shows approximate values of radio frequency power output when the equipment is used with antennas described in the preceding paragraphs

and under the following conditions:

1. Type of emission—CW.
2. Dynamotor input voltage—28 volts.

TABLE 6-3. R-F POWER OUTPUT

Frequency	Power Output Watts	Frequency	Power Output Watts
200Kc	4.0	5.5Mc	90.0
300Kc	7.5	7.0Mc	90.0
400Kc	11.0	9.0Mc	90.0
500Kc	14.5	11.5Mc	90.0
600Kc	18.0	13.5Mc	90.0
2.0Mc	30.0	15.5Mc	75.0
3.0Mc	60.0	18.1Mc	65.0
4.0Mc	80.0		

e. MODULATION.

(1) Class B modulation is employed in this equipment. The push-pull modulator tubes (V105 and V106) are capable of modulating the full-power R-F carrier at least 90 percent with VOICE emission.

f. POWER INPUT REQUIREMENTS.—Data in table 6-4 was computed under these conditions:

- (1) Input Voltage—28 volts D.C.

Note

Power sources should be capable of delivering 35 amperes.

(2) Transmitter tuned to 3.0 Mc and fully loaded to rated P.A. plate current.

TABLE 6-4. POWER INPUT REQUIREMENTS

Type of Emission	Power Input In Watts	
	Full Power	*Reduced Power
CW	780	700
CW (Stand By)	560	560
MCW	925	760
MCW (Stand By)	560	560
Voice	925	760
Voice (Stand By)	250	250

*Reduced power input occurs when aircraft reaches altitudes higher than 20,000 to 25,000 feet and barometric switch operates to reduce high voltage from 1150 to 750 volts.

g. DYNAMOTOR.—The dynamotor used with Models AN/ART-13A and AN/ART-13B may have been manufactured by either Russell Electric Co. or General Electric Co. Both machines are electrically and mechanically interchangeable when used on Dynamotor Unit DY-17/ART-13A. The rating and resistance measurements on the windings of each machine is shown in table 6-7. Schematic diagrams for both machines are shown at the bottom of figure 8-42.

b. TUBE COMPLEMENT.—The complete vacuum tube complement for this equipment is given in table 6-6.

TABLE 6-5. DYNAMOTOR CHARACTERISTICS AND RESISTANCE MEASUREMENTS

Manufacturer and Type	Rated Input	Rated Output	Shunt Field Resistance	Series Field Resistance	Resistance of Armature Winding Between Brushes		
					27 Volt Winding	400 Volt Winding	750 Volt Winding
Russell Dynamotor (Type 500D35WA)	27 volts, 32 amps	400 volts, 0.75 amps 750 volts, 0.35 amps	28.5 ohms	0.003 ohms	0.09	25	74
G. E. Dynamotor (Model 5DY81AC1)	27 volts, 33 amps	400 volts, 0.75 amps 750 volts, 0.35 amps	40 ohms	0.033 ohms	0.07	20	100
Eicor DY-17A/ART-13A	28 volts, 33 amps	410 volts, 0.75 amps 780 volts, 0.35 amps	26 ohms	0.01 ohms	0.05	28	80

TABLE 6-6. VACUUM TUBE COMPLEMENT

Symbol Designation	Type Number	Army-Navy Specification	Circuit Function
V101	JAN-837	JAN-1A	High Freq. VFO Oscillator
V102	JAN-1625	JAN-1A	1st Multiplier
V103	JAN-1625	JAN-1A	2nd Multiplier
V104	JAN-813	JAN-1A	Power Amplifier
V105	JAN-811	JAN-1A	Modulator
V106	JAN-811	JAN-1A	Modulator
V201	JAN-12SJ7	JAN-1A	1st Audio Amplifier
V202	JAN-6V6GT	JAN-1A	Audio Driver
V203	JAN-6V6GT	JAN-1A	Sidetone Amplifier
‡V801	JAN-6AQ5	JAN-1A	High Freq. Crystal Oscillator
‡V802	JAN-1625	JAN-1A	Low Freq. Crystal Oscillator
V2201	*JAN-12SL7GT	JAN-1A	} 1st Section is 200 Kc Calibration Oscillator } 2nd Section is Frequency Tripler Converter
V2202	†JAN-12SA7	JAN-1A	
V2203	*JAN-12SL7GT	JAN-1A	} 1st Section is Signal Detector } 2nd Section is MCW Audio Oscillator
V2601	JAN-1625	JAN-1A	

*Types JAN-12SL7GT or JAN-12SL7 may be used interchangeably.
†Types JAN-12SA7GT or JAN-SA7 may be used interchangeably.

‡Used only in AN/ART-13B

TABLE 6-7. SIDETONE OUTPUT

Switch Position	Output (rms. volts) ± 25%	Load Impedance (ohms)
1	0.7	125
2	1.4	125
3	2.5	125
4	5.0	125
5	10.0	125
6	20.0	2000

i. **AUDIO INPUT IMPEDANCE.**—The audio input circuit in the speech amplifier of this equipment is designed to match the output of either a carbon or dynamic microphone. A switch selects the proper input circuit that is to be used (switch is located behind chart panel on face of transmitter). When the switch is in the CARBON position the input circuit will match a carbon microphone of approximately 40 ohms internal resistance. When the switch is in the DYNAMIC position, the input circuit will match a dynamic microphone of approximately 200 ohms internal resistance.

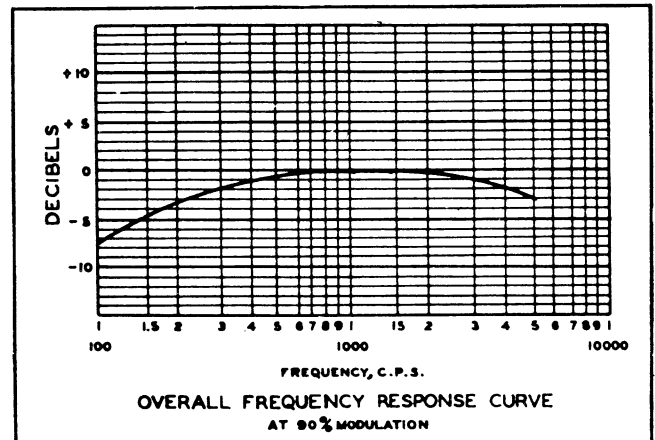

Figure 6-1. Overall Audio Frequency Response Curve

j. **OVERALL AUDIO FREQUENCY RESPONSE**—The following curve shows audio frequency response for either a carbon or dynamic microphone input.

k. SIDETONE OUTPUT.—Measurements in table 6-7 were made with 28 volts applied to the dynamotor input circuit and with control A in position 2. The transmitter was tuned to 3.0 Mc. P.A. PLATE current was 150 ma. and P.A. GRID current was 12 ma.

l. AUDIO INPUT.

Input required for 90 percent modulation at 1000 c.p.s.—Reduced power (750 v on plates of P.A. and Mod. Tubes)—

Carbon input—1.13 v required.

Dynamic input—11.7 mv required.

Full Power (1160 v on plates of P.A. & Mod. Tubes)—

Carbon input—1.52 v required.

Dynamic input—16.0 mv required.

m. NOISE LEVEL.

Below 100 percent modulation with input at 1000 cycles per second—Reduced Power (750 v on plates of P.A. & Mod. Tubes)—

Carbon input—(44 db).

Dynamic input—(43 db).

Full Power (1160 v on plates of P.A. & Mod. Tubes)—

Carbon input—(44 db).

Dynamic input—(45 db).

n. AUDIO DISTORTION.

Distortion with 90 percent modulation at 1000 cycles per second—Reduced Power (750 v on plates of P.A. & Mod. Tubes)—

Carbon input—6.5 percent distortion.

Dynamic input—6.5 percent distortion.

Full Power (1160 v on plates of P.A. & Mod. Tubes)—

Carbon input—7.0 percent distortion.

Dynamic input—7.0 percent distortion.

o. SIDETONE DISTORTION.

Distortion measured on output of SIDETONE at position 5 with 90 percent Modulation at 1000 cycles per second—

Reduced Power (750 v on plates of P.A. & Mod. Tubes)—

Carbon input—6.5 percent distortion.

Dynamic input—6.6 percent distortion.

Full Power (1160 v on plates of P.A. & Mod. Tubes)—

Carbon input—8.8 percent distortion.

Dynamic input—6.9 percent distortion.

p. RESISTANCE MEASUREMENTS OF AUTOTUNE MOTOR.—The autotune Motor (B101) used in this equipment was manufactured by three different firms. These motors are all electrically and mechanically interchangeable. Their respective field and winding resistances are shown in the table 6-8. A schematic diagram of the Autotune Motor is shown on the left side of figure 8-42.

TABLE 6-8. RESISTANCE MEASUREMENTS OF AUTOTUNE MOTOR

<i>Manufacturer</i>	<i>Shunt Field Resistance (F1 to F2)</i>	<i>Resistance of Armature Winding Across Diametrically Opposite Bars</i>	<i>Resistance of Armature Winding Between Adjacent Commutator Segments</i>
Emerson Electric Co.	18.0 ohms	1.35 ohms	0.3 ohms
Fractional Motors	21.0 ohms	1.06 ohms	0.166 ohms
Ohio Electric Mfg. Co.	26.0 ohms	6.15 ohms	1.16 ohms

(Calibration Tables begin on following page.)



**TABLE 6-9. CALIBRATION OF LOW FREQUENCY OSCILLATOR
200KC TO 600KC**

Frequency: 200-300 Kc

Freq. A F G	Freq. A F G	Freq. A F G
200 13 1 189.2	234 13 1 890.2	269 13 1 1604.0
201 13 1 212.0	235 13 1 910.6	270 13 1 1624.5
202 13 1 234.8	236 13 1 931.0	271 13 1 1645.6
203 13 1 256.8	237 13 1 951.3	272 13 1 1666.0
204 13 1 278.0	238 13 1 971.7	273 13 1 1686.5
205 13 1 299.8	239 13 1 992.0	274 13 1 1707.2
206 13 1 321.3	240 13 1 1012.4	275 13 1 1728.8
207 13 1 342.8	241 13 1 1032.8	276 13 1 1750.0
208 13 1 363.6	242 13 1 1053.3	277 13 1 1771.0
209 13 1 384.3	243 13 1 1073.7	278 13 1 1792.0
	244 13 1 1094.2	279 13 1 1814.0
210 13 1 405.0	245 13 1 1114.6	
211 13 1 425.3	246 13 1 1135.0	280 13 1 1836.0
212 13 1 445.6	247 13 1 1155.5	281 13 1 1858.0
213 13 1 466.5	248 13 1 1175.9	282 13 1 1880.0
214 13 1 486.7	249 13 1 1196.4	283 13 1 1902.2
215 13 1 508.1	250 13 1 1216.8	284 13 1 1925.2
216 13 1 527.5	251 13 1 1237.1	285 13 1 1948.5
217 13 1 548.0	252 13 1 1257.4	
218 13 1 568.0	253 13 1 1277.8	286 13 2 118.8
219 13 1 588.0	254 13 1 1298.1	287 13 2 135.7
	255 13 1 1318.4	288 13 2 152.2
220 13 1 608.0	256 13 1 1338.7	289 13 2 168.2
221 13 1 628.1	257 13 1 1359.0	290 13 2 200.2
222 13 1 648.2	258 13 1 1379.4	291 13 2 215.5
223 13 1 668.2	259 13 1 1399.7	292 13 2 231.0
224 13 1 688.3	260 13 1 1420.0	293 13 2 246.8
225 13 1 708.4	261 13 1 1440.0	294 13 2 261.8
226 13 1 728.5	262 13 1 1460.9	295 13 2 276.5
227 13 1 748.6	263 13 1 1481.4	296 13 2 291.4
228 13 1 768.6	264 13 1 1501.8	297 13 2 306.5
229 13 1 788.7	265 13 1 1522.2	298 13 2 321.5
	266 13 1 1542.7	299 13 2 336.2
230 13 1 808.8	267 13 1 1563.1	
231 13 1 829.2	268 13 1 1583.6	300 13 2 350.8
232 13 1 849.5		
233 13 1 869.9		

Use nearest check point shown in heavy type

Frequency: 400-500 Kc

Freq. A F G	Freq. A F G	Freq. A F G
400 13 2 1764.8	433 13 3 320.4	468 13 3 662.6
401 13 2 1779.0	434 13 3 330.4	469 13 3 672.2
402 13 2 1793.7	435 13 3 340.6	
403 13 2 1809.0	436 13 3 350.8	470 13 3 681.8
404 13 2 1824.0	437 13 3 360.8	471 13 3 691.4
405 13 2 1839.4	438 13 3 370.6	472 13 3 701.0
406 13 2 1854.4	439 13 3 380.4	473 13 3 710.5
407 13 2 1869.4	440 13 3 390.4	474 13 3 720.1
408 13 2 1885.0	441 13 3 400.3	475 13 3 729.7
409 13 2 1900.2	442 13 3 410.1	476 13 3 739.3
	443 13 3 420.0	477 13 3 748.9
410 13 2 1916.2	444 13 3 429.8	478 13 3 758.4
411 13 2 1932.2	445 13 3 439.7	479 13 3 768.0
412 13 2 1948.2	446 13 3 449.6	
413 13 2 1964.4	447 13 3 459.4	480 13 3 777.6
414 13 2 1980.3	448 13 3 469.3	481 13 3 787.3
415 13 2 1997.0	449 13 3 479.1	482 13 3 796.9
		483 13 3 806.6
415 13 3 127.2	450 13 3 489.0	484 13 3 816.2
416 13 3 138.6	451 13 3 498.7	485 13 3 825.9
417 13 3 150.2	452 13 3 508.4	486 13 3 835.6
418 13 3 161.3	453 13 3 518.0	487 13 3 845.2
419 13 3 172.2	454 13 3 527.7	488 13 3 854.9
	455 13 3 537.4	489 13 3 864.5
420 13 3 183.0	456 13 3 547.1	
421 13 3 193.8	457 13 3 556.8	490 13 3 874.2
422 13 3 205.0	458 13 3 566.4	491 13 3 884.0
423 13 3 215.6	459 13 3 576.1	492 13 3 893.7
424 13 3 226.6	460 13 3 585.8	493 13 3 903.5
425 13 3 237.2	461 13 3 595.4	494 13 3 913.2
426 13 3 247.7	462 13 3 605.0	495 13 3 923.3
427 13 3 258.2	463 13 3 614.6	496 13 3 932.8
428 13 3 268.4	464 13 3 624.2	497 13 3 942.5
429 13 3 277.7	465 13 3 633.8	498 13 3 952.3
	466 13 3 643.4	499 13 3 962.0
430 13 3 289.2	467 13 3 653.0	500 13 3 971.8
431 13 3 299.6		
432 13 3 310.2		

Use nearest check point shown in heavy type

Frequency: 300-400 Kc

Freq. A F G	Freq. A F G	Freq. A F G
300 13 2 350.8	334 13 2 829.0	368 13 2 1309.2
301 13 2 365.7	335 13 2 843.0	369 13 2 1323.3
302 13 2 379.4	336 13 2 857.0	
303 13 2 394.5	337 13 2 871.0	370 13 2 1337.5
304 13 2 408.7	338 13 2 885.0	371 13 2 1351.5
305 13 2 423.5	339 13 2 899.0	372 13 2 1365.6
306 13 2 438.7	340 13 2 913.0	373 13 2 1379.6
307 13 2 452.0	341 13 2 927.2	374 13 2 1393.6
308 13 2 466.0	342 13 2 941.4	375 13 2 1407.6
309 13 2 480.0	343 13 2 955.6	376 13 2 1421.7
	344 13 2 969.8	377 13 2 1435.7
310 13 2 494.0	345 13 2 984.0	378 13 2 1449.7
311 13 2 509.2	346 13 2 998.2	379 13 2 1463.7
312 13 2 522.4	347 13 2 1012.4	
313 13 2 536.6	348 13 2 1026.6	380 13 2 1477.8
314 13 2 550.6	349 13 2 1040.8	381 13 2 1492.0
315 13 2 564.4	350 13 2 1055.0	382 13 2 1506.2
316 13 2 578.4	351 13 2 1069.1	383 13 2 1520.3
317 13 2 592.2	352 13 2 1083.2	384 13 2 1534.5
318 13 2 606.2	353 13 2 1097.3	385 13 2 1548.7
319 13 2 620.2	354 13 2 1111.4	386 13 2 1562.9
	355 13 2 1125.5	387 13 2 1577.1
320 13 2 634.2	356 13 2 1139.6	388 13 2 1591.2
321 13 2 648.1	357 13 2 1153.7	389 13 2 1605.4
322 13 2 662.0	358 13 2 1167.8	
323 13 2 675.8	359 13 2 1181.9	390 13 2 1619.6
324 13 2 689.7	360 13 2 1196.0	391 13 2 1634.1
325 13 2 703.6	361 13 2 1210.1	392 13 2 1648.6
326 13 2 717.5	362 13 2 1224.3	393 13 2 1663.2
327 13 2 731.4	363 13 2 1238.4	394 13 2 1677.7
328 13 2 745.2	364 13 2 1252.6	395 13 2 1692.2
329 13 2 759.1	365 13 2 1266.7	396 13 2 1706.7
	366 13 2 1280.9	397 13 2 1721.2
330 13 2 773.0	367 13 2 1295.0	398 13 2 1735.7
331 13 2 786.4		399 13 2 1750.3
332 13 2 801.0		
333 13 2 815.0		400 13 2 1764.8

Use nearest check point shown in heavy type

Frequency: 500-600 Kc

Freq. A F G	Freq. A F G	Freq. A F G
500 13 3 971.8	534 13 3 1303.2	568 13 3 1634.3
501 13 3 981.6	535 13 3 1312.9	569 13 3 1644.0
502 13 3 991.3	536 13 3 1322.6	
503 13 3 1001.1	537 13 3 1332.3	570 13 3 1653.8
504 13 3 1010.9	538 13 3 1342.0	571 13 3 1663.8
505 13 3 1020.6	539 13 3 1351.7	572 13 3 1673.2
506 13 3 1030.4	540 13 3 1361.4	573 13 3 1682.0
507 13 3 1040.2	541 13 3 1371.1	574 13 3 1692.8
508 13 3 1050.0	542 13 3 1380.8	575 13 3 1703.0
509 13 3 1059.7	543 13 3 1390.4	576 13 3 1713.0
	544 13 3 1400.1	577 13 3 1723.0
510 13 3 1069.5	545 13 3 1409.8	578 13 3 1733.4
511 13 3 1079.2	546 13 3 1419.5	579 13 3 1743.4
512 13 3 1089.0	547 13 3 1429.2	
	548 13 3 1438.8	580 13 3 1753.4
513 13 3 1098.8	549 13 3 1448.5	581 13 3 1763.4
514 13 3 1108.5		582 13 3 1773.2
515 13 3 1118.2	550 13 3 1458.2	583 13 3 1783.2
516 13 3 1128.0	551 13 3 1467.9	584 13 3 1793.8
517 13 3 1137.7	552 13 3 1477.7	585 13 3 1804.0
518 13 3 1147.5	553 13 3 1487.4	586 13 3 1814.4
519 13 3 1157.3	554 13 3 1497.1	587 13 3 1824.8
	555 13 3 1506.9	
520 13 3 1167.0	556 13 3 1516.6	590 13 3 1856.2
521 13 3 1176.8	557 13 3 1526.3	591 13 3 1866.4
522 13 3 1186.5	558 13 3 1536.1	592 13 3 1877.0
523 13 3 1196.2	559 13 3 1545.9	593 13 3 1887.5
524 13 3 1206.0	560 13 3 1555.6	594 13 3 1898.0
525 13 3 1215.7	561 13 3 1565.4	595 13 3 1909.0
526 13 3 1225.5	562 13 3 1575.2	596 13 3 1920.0
527 13 3 1235.2	563 13 3 1585.1	597 13 3 1931.0
528 13 3 1245.0	564 13 3 1594.9	598 13 3 1942.0
529 13 3 1254.7	565 13 3 1604.7	599 13 3 1953.0
	566 13 3 1614.5	
530 13 3 1264.5	567 13 3 1624.3	600 13 3 1964.0
531 13 3 1274.2		
532 13 3 1283.9		
533 13 3 1293.6		

Use nearest check point shown in heavy type

**TABLE 6-10. CALIBRATION OF HIGH FREQUENCY OSCILLATOR
200KC TO 1810KC**

Frequency: 2000—2100 Kc

Freq.	A	B	Freq.	A	B	Freq.	A	B
2000	1	100.1	2034	1	225.4	2068	1	350.8
2001	1	103.8	2035	1	229.1	2069	1	354.5
2002	1	107.5	2036	1	232.7			
2003	1	111.2	2037	1	236.4	2070	1	358.1
2004	1	114.9	2038	1	240.1	2071	1	361.8
2005	1	118.6	2039	1	243.8	2072	1	365.5
2006	1	122.3				2073	1	369.2
2007	1	126.0	2040	1	247.4	2074	1	372.9
2008	1	129.7	2041	1	251.1	2075	1	376.6
2009	1	133.4	2042	1	254.8	2076	1	380.3
			2043	1	258.5	2077	1	384.0
2010	1	137.1	2044	1	262.2	2078	1	387.7
2011	1	140.8	2045	1	265.9	2079	1	391.4
2012	1	144.5	2046	1	269.6			
2013	1	148.2	2047	1	273.2	2080	1	395.1
2014	1	151.9	2048	1	276.9	2081	1	398.8
2015	1	155.6	2049	1	280.6	2082	1	402.5
2016	1	159.2				2083	1	406.2
2017	1	162.9	2050	1	284.3	2084	1	410.0
2018	1	166.6	2051	1	288.0	2085	1	413.7
2019	1	170.3	2052	1	291.7	2086	1	417.4
			2053	1	295.4	2087	1	421.2
2020	1	174.0	2054	1	299.1	2088	1	424.9
2021	1	177.7	2055	1	302.8	2089	1	428.6
2022	1	181.3	2056	1	306.5			
2023	1	185.0	2057	1	310.2	2090	1	432.3
2024	1	188.7	2058	1	313.9	2091	1	436.1
2025	1	192.3	2059	1	317.5	2092	1	439.8
2026	1	196.0				2093	1	443.5
2027	1	199.7	2060	1	321.2	2094	1	447.2
2028	1	203.4	2061	1	324.9	2095	1	451.0
2029	1	207.0	2062	1	328.6	2096	1	454.7
			2063	1	332.3	2097	1	458.4
2030	1	210.7	2064	1	336.0	2098	1	462.1
2031	1	214.4	2065	1	339.7	2099	1	465.9
2032	1	218.0	2066	1	343.4			
2033	1	221.7	2067	1	347.1	2100	1	469.6

Use check point at 2000 or 2100 Kc, whichever is nearer

Frequency: 2200—2300 Kc

Freq.	A	B	Freq.	A	B	Freq.	A	B
2200	1	843.0	2234	1	969.1	2268	1	1094.6
2201	1	846.7	2235	1	972.8	2269	1	1098.2
2202	1	850.4	2236	1	976.5			
2203	1	854.1	2237	1	980.2	2270	1	1101.9
2204	1	857.8	2238	1	983.9	2271	1	1105.6
2205	1	861.6	2239	1	987.6	2272	1	1109.3
2206	1	865.3				2273	1	1112.9
2207	1	869.0	2240	1	991.2	2274	1	1116.6
2208	1	872.7	2241	1	994.9	2275	1	1120.3
2209	1	876.4	2242	1	998.6	2276	1	1123.9
			2243	1	1002.3	2277	1	1127.6
2210	1	880.1	2244	1	1006.0	2278	1	1131.3
2211	1	883.8	2245	1	1009.8	2279	1	1134.9
2212	1	887.5	2246	1	1013.5			
2213	1	891.3	2247	1	1017.2	2280	1	1138.6
2214	1	895.0	2248	1	1020.9	2281	1	1142.3
2215	1	898.7	2249	1	1024.6	2282	1	1145.9
2216	1	902.4				2283	1	1149.6
2217	1	906.1	2250	1	1028.3	2284	1	1153.3
2218	1	909.8	2251	1	1032.0	2285	1	1156.9
2219	1	913.5	2252	1	1035.7	2286	1	1160.6
			2253	1	1039.4	2287	1	1164.2
2220	1	917.2	2254	1	1043.1	2288	1	1167.9
2221	1	921.0	2255	1	1046.8	2289	1	1171.6
2222	1	924.7	2256	1	1050.5			
2223	1	928.4	2257	1	1054.2	2290	1	1175.2
2224	1	932.1	2258	1	1057.9	2291	1	1178.9
2225	1	935.8	2259	1	1061.6	2292	1	1182.5
2226	1	939.5				2293	1	1186.2
2227	1	943.2	2260	1	1065.3	2294	1	1189.9
2228	1	946.9	2261	1	1068.9	2295	1	1193.5
2229	1	950.6	2262	1	1072.6	2296	1	1197.2
			2263	1	1076.3	2297	1	1200.8
2230	1	954.3	2264	1	1079.9	2298	1	1204.5
2231	1	958.0	2265	1	1083.6	2299	1	1208.1
2232	1	961.7	2266	1	1087.3			
2233	1	965.4	2267	1	1090.9	2300	1	1211.8

Use check point at 2200 or 2300 Kc, whichever is nearer

Frequency: 2100—2200 Kc

Freq.	A	B	Freq.	A	B	Freq.	A	B
2100	1	469.6	2134	1	596.4	2168	1	723.5
2101	1	473.3	2135	1	600.1	2169	1	727.2
2102	1	477.0	2136	1	603.9			
2103	1	480.7	2137	1	607.6	2170	1	731.0
2104	1	484.4	2138	1	611.4	2171	1	734.7
2105	1	488.2	2139	1	615.1	2172	1	738.5
2106	1	491.9				2173	1	742.2
2107	1	495.6	2140	1	618.8	2174	1	746.0
2108	1	499.3	2141	1	622.6	2175	1	749.7
2109	1	503.0	2142	1	626.3	2176	1	753.5
			2143	1	630.1	2177	1	757.2
2110	1	506.7	2144	1	633.8	2178	1	761.0
2111	1	510.5	2145	1	637.5	2179	1	764.7
2112	1	514.2	2146	1	641.3			
2113	1	517.9	2147	1	645.0	2180	1	768.5
2114	1	521.7	2148	1	648.8	2181	1	772.2
2115	1	525.4	2149	1	652.5	2182	1	775.9
2116	1	529.2				2183	1	779.6
2117	1	532.9	2150	1	656.2	2184	1	783.3
2118	1	536.6	2151	1	660.0	2185	1	787.1
2119	1	540.4	2152	1	663.7	2186	1	790.8
			2153	1	667.4	2187	1	794.5
2120	1	544.1	2154	1	671.2	2188	1	798.2
2121	1	547.9	2155	1	674.9	2189	1	802.0
2122	1	551.6	2156	1	678.6			
2123	1	555.3	2157	1	682.4	2190	1	805.7
2124	1	559.0	2158	1	686.1	2191	1	809.4
2125	1	562.8	2159	1	689.8	2192	1	813.1
2126	1	566.5				2193	1	816.9
2127	1	570.2	2160	1	693.6	2194	1	820.6
2128	1	574.0	2161	1	697.3	2195	1	824.3
2129	1	577.7	2162	1	701.1	2196	1	828.1
			2163	1	704.8	2197	1	831.8
2130	1	581.4	2164	1	708.5	2198	1	835.5
2131	1	585.2	2165	1	712.3	2199	1	839.3
2132	1	588.9	2166	1	716.0			
2133	1	592.6	2167	1	719.8	2200	1	843.0

Use check point at 2100 or 2200 Kc, whichever is nearer

Frequency: 2300—2400 Kc

Freq.	A	B	Freq.	A	B	Freq.	A	B
2300	1	1211.8	2334	1	1336.2	2368	1	1460.6
2301	1	1215.4	2335	1	1339.8	2369	1	1464.2
2302	1	1219.1	2336	1	1343.5			
2303	1	1222.7	2337	1	1347.1	2370	1	1467.9
2304	1	1226.4	2338	1	1350.8	2371	1	1471.6
2305	1	1230.0	2339	1	1354.5	2372	1	1475.3
2306	1	1233.7				2373	1	1479.0
2307	1	1237.3	2340	1	1358.1	2374	1	1482.7
2308	1	1241.0	2341	1	1361.8	2375	1	1486.4
2309	1	1244.6	2342	1	1365.4	2376	1	1490.0
			2343	1	1369.1	2377	1	1493.7
2310	1	1248.3	2344	1	1372.7	2378	1	1497.4
2311	1	1252.0	2345	1	1376.4	2379	1	1501.1
2312	1	1255.6	2346	1	1380.0			
2313	1	1259.3	2347	1	1383.7	2380	1	1504.8
2314	1	1262.9	2348	1	1387.3	2381	1	1508.5
2315	1	1266.6	2349	1	1391.0	2382	1	1512.2
2316	1	1270.2				2383	1	1

**TABLE 6-10. CALIBRATION OF HIGH FREQUENCY OSCILLATOR
2000Kc TO 18100Kc**

Frequency: 2400—2500 Kc

Freq.	A	B	Freq.	A	B	Freq.	A	B
2400	2	60.0	2434	2	164.0	2468	2	267.4
2401	2	63.1	2435	2	167.0	2469	2	270.4
2402	2	66.1	2436	2	170.0			
2403	2	69.2	2437	2	173.1	2470	2	273.5
2404	2	72.3	2438	2	176.1	2471	2	276.5
2405	2	75.3	2439	2	179.1	2472	2	279.6
2406	2	78.4				2473	2	282.6
2407	2	81.5	2440	2	182.2	2474	2	285.7
2408	2	84.5	2441	2	185.2	2475	2	288.7
2409	2	87.6	2442	2	188.3	2476	2	291.7
			2443	2	191.3	2477	2	294.8
2410	2	90.7	2444	2	194.3	2478	2	297.8
2411	2	93.7	2445	2	197.4	2479	2	300.9
2412	2	96.8	2446	2	200.4			
2413	2	99.9	2447	2	203.5	2480	2	303.9
2414	2	102.9	2448	2	206.5	2481	2	307.0
2415	2	106.0	2449	2	209.6	2482	2	310.0
2416	2	109.1				2483	2	313.1
2417	2	112.1	2450	2	212.6	2484	2	316.1
2418	2	115.2	2451	2	215.6	2485	2	319.2
2419	2	118.3	2452	2	218.7	2486	2	322.2
			2453	2	221.7	2487	2	325.3
2420	2	121.3	2454	2	224.7	2488	2	328.4
2421	2	124.4	2455	2	227.8	2489	2	331.4
2422	2	127.4	2456	2	230.8			
2423	2	130.5	2457	2	233.9	2490	2	334.5
2424	2	133.5	2458	2	236.9	2491	2	337.5
2425	2	136.6	2459	2	239.9	2492	2	340.6
2426	2	139.6				2493	2	343.7
2427	2	142.7	2460	2	243.0	2494	2	346.8
2428	2	145.7	2461	2	246.0	2495	2	349.8
2429	2	148.8	2462	2	249.1	2496	2	352.9
			2463	2	252.1	2497	2	356.0
2430	2	151.8	2464	2	255.2	2498	2	359.0
2431	2	154.9	2465	2	258.2	2499	2	362.1
2432	2	157.9	2466	2	261.3			
2433	2	160.9	2467	2	264.3	2500	2	365.2

Use check point at 2400 or 2500 Kc, whichever is nearer

Frequency: 2600—2700 Kc

Freq.	A	B	Freq.	A	B	Freq.	A	B
2600	2	673.4	2634	2	778.3	2668	2	883.1
2601	2	676.5	2635	2	781.4	2669	2	886.1
2602	2	679.6	2636	2	784.5			
2603	2	682.7	2637	2	787.6	2670	2	889.1
2604	2	685.7	2638	2	790.7	2671	2	892.2
2605	2	688.8	2639	2	793.8	2672	2	895.3
2606	2	691.9				2673	2	898.4
2607	2	695.0	2640	2	796.9	2674	2	901.5
2608	2	698.1	2641	2	800.0	2675	2	904.6
2609	2	701.2	2642	2	803.1	2676	2	907.7
			2643	2	806.2	2677	2	910.8
2610	2	704.2	2644	2	809.3	2678	2	913.8
2611	2	707.3	2645	2	812.4	2679	2	916.9
2612	2	710.4	2646	2	815.5			
2613	2	713.5	2647	2	818.6	2680	2	920.0
2614	2	716.6	2648	2	821.7	2681	2	923.1
2615	2	719.7	2649	2	824.8	2682	2	926.1
2616	2	722.8				2683	2	929.2
2617	2	726.0	2650	2	828.0	2684	2	932.3
2618	2	729.1	2651	2	831.0	2685	2	935.3
2619	2	732.2	2652	2	834.1	2686	2	938.4
			2653	2	837.2	2687	2	941.5
2620	2	735.3	2654	2	840.3	2688	2	944.5
2621	2	738.3	2655	2	843.4	2689	2	947.6
2622	2	741.4	2656	2	846.4			
2623	2	744.5	2657	2	849.5	2690	2	950.7
2624	2	747.5	2658	2	852.6	2691	2	953.7
2625	2	750.6	2659	2	855.7	2692	2	956.8
2626	2	753.7				2693	2	959.9
2627	2	756.8	2660	2	858.8	2694	2	962.9
2628	2	759.8	2661	2	861.8	2695	2	966.0
2629	2	762.9	2662	2	864.8	2696	2	969.1
			2663	2	867.9	2697	2	972.2
2630	2	766.0	2664	2	870.9	2698	2	975.2
2631	2	769.1	2665	2	874.0	2699	2	978.3
2632	2	772.1	2666	2	877.0			
2633	2	775.2	2667	2	880.0	2700	2	981.4

Use check point at 2600 or 2700 Kc, whichever is nearer

Frequency: 2500—2600 Kc

Freq.	A	B	Freq.	A	B	Freq.	A	B
2500	2	365.2	2534	2	469.5	2568	2	574.4
2501	2	368.2	2535	2	472.5	2569	2	577.5
2502	2	371.3	2536	2	475.6			
2503	2	374.3	2537	2	478.6	2570	2	580.6
2504	2	377.3	2538	2	481.7	2571	2	583.7
2505	2	380.4	2539	2	484.8	2572	2	586.8
2506	2	383.4				2573	2	589.9
2507	2	386.5	2540	2	487.8	2574	2	593.0
2508	2	389.5	2541	2	490.9	2575	2	596.1
2509	2	392.6	2542	2	494.0	2576	2	599.2
			2543	2	497.2	2577	2	602.3
2510	2	395.6	2544	2	500.3	2578	2	605.4
2511	2	398.7	2545	2	503.4	2579	2	608.5
2512	2	401.8	2546	2	506.5			
2513	2	404.8	2547	2	509.6	2580	2	611.6
2514	2	407.9	2548	2	512.7	2581	2	614.7
2515	2	411.0	2549	2	515.8	2582	2	617.8
2516	2	414.1				2583	2	620.9
2517	2	417.2	2550	2	518.9	2584	2	623.9
2518	2	420.2	2551	2	522.0	2585	2	627.0
2519	2	423.3	2552	2	525.1	2586	2	630.1
			2553	2	528.2	2587	2	633.2
2520	2	426.4	2554	2	531.2	2588	2	636.3
2521	2	429.5	2555	2	534.3	2589	2	639.4
2522	2	432.6	2556	2	537.4			
2523	2	435.6	2557	2	540.5	2590	2	642.5
2524	2	438.7	2558	2	543.6	2591	2	645.6
2525	2	441.8	2559	2	546.6	2592	2	648.7
2526	2	444.9				2593	2	651.8
2527	2	448.0	2560	2	549.7	2594	2	654.9
2528	2	451.1	2561	2	552.8	2595	2	658.0
2529	2	454.2	2562	2	555.9	2596	2	661.1
			2563	2	559.0	2597	2	664.1
2530	2	457.2	2564	2	562.1	2598	2	667.2
2531	2	460.3	2565	2	565.2	2599	2	670.3
2532	2	463.4	2566	2	568.2			
2533	2	466.4	2567	2	571.3	2600	2	673.4

Use check point at 2500 or 2600 Kc, whichever is nearer

Frequency: 2700—2800 Kc

Freq.	A	B	Freq.	A	B	Freq.	A	B
2700	2	981.4	2734	2	1085.2	2768	2	1188.4
2701	2	984.4	2735	2	1088.2	2769	2	1191.4
2702	2	987.5	2736	2	1091.3			
2703	2	990.5	2737	2	1094.3	2770	2	1194.4
2704	2	993.6	2738	2	1097.3	2771	2	1197.5
2705	2	996.7	2739	2	1100.4	2772	2	1200.5
2706	2	999.7				2773	2	1203.6
2707	2	1002.8	2740	2	1103.4	2774	2	1206.6
2708	2	1005.8	2741	2	1106.5	2775	2	1209.7
2709	2	1008.9	2742	2	1109.5	2776	2	1212.7
			2743	2	1112.6	2777	2	1215.8
2710	2	1012.0	2744	2	1115.6	2778	2	1218.8
2711	2	1015.0	2745	2	1118.6	2779	2	1221.9
2712	2	1018.1	2746	2	1121.7			
2713	2	1021.1	2747	2	1124.7	2780	2	1224.9
2714	2	1024.2	2748	2	1127.8	2781	2	1227.9
2715	2	1027.2	2749	2	1130.8	2782	2	1230.9
2716	2	1030.3				2783	2	1234.0
2717	2	1033.3	2750	2	1133.8			

**TABLE 6-10. CALIBRATION OF HIGH FREQUENCY OSCILLATOR
2000KC TO 18100KC**

Frequency: 2800—2900 Kc

Freq.	A	B	Freq.	A	B	Freq.	A	B
2800	2	1285.3	2834	2	1388.4	2868	2	1491.9
2801	2	1288.3	2835	2	1391.4	2869	2	1495.0
2802	2	1291.4	2836	2	1394.5			
2803	2	1294.4	2837	2	1397.5	2870	2	1498.0
2804	2	1297.4	2838	2	1400.5	2871	2	1501.1
2805	2	1300.5	2839	2	1403.6	2872	2	1504.2
2806	2	1303.5				2873	2	1507.2
2807	2	1306.6	2840	2	1406.6	2874	2	1510.3
2808	2	1309.6	2841	2	1409.6	2875	2	1513.4
2809	2	1312.6	2842	2	1412.7	2876	2	1516.4
			2843	2	1415.7	2877	2	1519.5
2810	2	1315.7	2844	2	1418.8	2878	2	1522.5
2811	2	1318.7	2845	2	1421.8	2879	2	1525.6
2812	2	1321.7	2846	2	1424.9			
2813	2	1324.8	2847	2	1427.9	2880	2	1528.7
2814	2	1327.8	2848	2	1431.0	2881	2	1531.7
2815	2	1330.8	2849	2	1434.0	2882	2	1534.8
2816	2	1333.8				2883	2	1537.9
2817	2	1336.9	2850	2	1437.1	2884	2	1540.9
2818	2	1339.9	2851	2	1440.1	2885	2	1544.0
2819	2	1342.9	2852	2	1443.2	2886	2	1547.0
			2853	2	1446.2	2887	2	1550.1
2820	2	1346.0	2854	2	1449.3	2888	2	1553.2
2821	2	1349.0	2855	2	1452.4	2889	2	1556.2
2822	2	1352.0	2856	2	1455.4			
2823	2	1355.1	2857	2	1458.5	2890	2	1559.3
2824	2	1358.1	2858	2	1461.5	2891	2	1562.4
2825	2	1361.1	2859	2	1464.6	2892	2	1565.4
2826	2	1364.2				2893	2	1568.5
2827	2	1367.2	2860	2	1467.6	2894	2	1571.6
2828	2	1370.2	2861	2	1470.7	2895	2	1574.7
2829	2	1373.2	2862	2	1473.7	2896	2	1577.8
			2863	2	1476.8	2897	2	1580.8
2830	2	1376.3	2864	2	1479.8	2898	2	1583.9
2831	2	1379.3	2865	2	1482.8	2899	2	1587.0
2832	2	1382.3	2866	2	1485.9			
2833	2	1385.4	2867	2	1488.9	2900	2	1590.1

Use check point a 2800 or 2900 Kc, whichever is nearer

Frequency: 3000—3100 Kc

Freq.	A	B	Freq.	A	B	Freq.	A	B
3000	3	100.1	3034	3	183.8	3068	3	267.1
3001	3	102.6	3035	3	186.2	3069	3	269.6
3002	3	105.1	3036	3	188.7			
3003	3	107.5	3037	3	191.1	3070	3	272.0
3004	3	110.0	3038	3	193.6	3071	3	274.5
3005	3	112.5	3039	3	196.0	3072	3	276.9
3006	3	114.9				3073	3	279.4
3007	3	117.4	3040	3	198.5	3074	3	281.8
3008	3	119.9	3041	3	200.9	3075	3	284.3
3009	3	122.3	3042	3	203.4	3076	3	286.8
			3043	3	205.8	3077	3	289.2
3010	3	124.8	3044	3	208.3	3078	3	291.7
3011	3	127.3	3045	3	210.7	3079	3	294.1
3012	3	129.7	3046	3	213.2			
3013	3	132.2	3047	3	215.6	3080	3	296.6
3014	3	134.7	3048	3	218.1	3081	3	299.1
3015	3	137.1	3049	3	220.5	3082	3	301.5
3016	3	139.6				3083	3	304.0
3017	3	142.1	3050	3	223.0	3084	3	306.5
3018	3	144.5	3051	3	225.4	3085	3	308.9
3019	3	147.0	3052	3	227.9	3086	3	311.4
			3053	3	230.3	3087	3	313.9
3020	3	149.4	3054	3	232.8	3088	3	316.3
3021	3	151.9	3055	3	235.2	3089	3	318.8
3022	3	154.3	3056	3	237.7			
3023	3	156.8	3057	3	240.1	3090	3	321.2
3024	3	159.3	3058	3	242.6	3091	3	323.7
3025	3	161.7	3059	3	245.0	3092	3	326.2
3026	3	164.2				3093	3	328.6
3027	3	166.6	3060	3	247.5	3094	3	331.1
3028	3	169.1	3061	3	249.9	3095	3	333.5
3029	3	171.5	3062	3	252.4	3096	3	336.0
			3063	3	254.8	3097	3	338.5
3030	3	174.0	3064	3	257.3	3098	3	340.9
3031	3	176.4	3065	3	259.7	3099	3	343.4
3032	3	178.9	3066	3	262.2			
3033	3	181.3	3067	3	264.6	3100	3	345.8

Use check point at 3000 or 3100 Kc, whichever is nearer

Frequency: 2900—3000 Kc

Freq.	A	B	Freq.	A	B	Freq.	A	B
2900	2	1590.1	2934	2	1696.2	2968	2	1804.7
2901	2	1593.2	2935	2	1699.3	2969	2	1808.0
2902	2	1596.3	2936	2	1702.5			
2903	2	1599.4	2937	2	1705.7	2970	2	1811.2
2904	2	1602.5	2938	2	1708.8	2971	2	1814.4
2905	2	1605.6	2939	2	1712.0	2972	2	1817.7
2906	2	1608.7				2973	2	1820.9
2907	2	1611.8	2940	2	1715.1	2974	2	1824.2
2908	2	1614.9	2941	2	1718.3	2975	2	1827.4
2909	2	1618.0	2942	2	1721.5	2976	2	1830.7
			2943	2	1724.6	2977	2	1833.9
2910	2	1621.1	2944	2	1727.8	2978	2	1837.2
2911	2	1624.2	2945	2	1731.0	2979	2	1840.4
2912	2	1627.3	2946	2	1734.1			
2913	2	1630.4	2947	2	1737.3	2980	2	1843.7
2914	2	1633.5	2948	2	1740.5	2981	2	1847.0
2915	2	1636.7	2949	2	1743.6	2982	2	1850.3
2916	2	1639.8				2983	2	1853.6
2917	2	1642.9	2950	2	1746.8	2984	2	1856.9
2918	2	1646.0	2951	2	1750.0	2985	2	1860.2
2919	2	1649.1	2952	2	1753.2	2986	2	1863.5
			2953	2	1756.4	2987	2	1866.8
2920	2	1652.3	2954	2	1759.6	2988	2	1870.1
2921	2	1655.4	2955	2	1762.8	2989	2	1873.5
2922	2	1658.5	2956	2	1766.0			
2923	2	1661.7	2957	2	1769.3	2990	2	1876.8
2924	2	1664.8	2958	2	1772.5	2991	2	1880.1
2925	2	1667.9	2959	2	1775.7	2992	2	1883.4
2926	2	1671.0				2993	2	1886.7
2927	2	1674.2	2960	2	1778.9	2994	2	1890.1
2928	2	1677.3	2961	2	1782.1	2995	2	1893.4
2929	2	1680.4	2962	2	1785.3	2996	2	1896.7
			2963	2	1788.6	2997	2	1900.0
2930	2	1683.6	2964	2	1791.8	2998	2	1903.4
2931	2	1686.7	2965	2	1795.0	2999	2	1906.7
2932	2	1689.9	2966	2	1798.3			
2933	2	1693.0	2967	2	1801.5	3000	2	1910.0

Use check point at 2900 or 3000 Kc, whichever is nearer

Frequency: 3100—3200 Kc

Freq.	A	B	Freq.	A	B	Freq.	A	B
3100	3	345.8	3134	3	429.8	3168	3	514.2
3101	3	348.3	3135	3	432.3	3169	3	516.7
3102	3	350.8	3136	3	434.8			
3103	3	353.2	3137	3	437.3	3170	3	519.2
3104	3	355.7	3138	3	439.8	3171	3	521.7
3105	3	358.1	3139	3	442.3	3172	3	524.2
3106	3	360.6				3173	3	526.7
3107	3	363.1	3140	3	444.7	3174	3	529.2
3108	3	365.5	3141	3	447.2	3175	3	531.7
3109	3	368.0	3142	3	449.7	3176	3	534.1
			3143	3	452.2	3177	3	536.6
3110	3	370.4	3144	3	454.7	3178	3	539.1
3111	3	372.9	3145	3	457.2	3179	3	541.6
3112	3	375.4	3146	3	459.6			
3113	3	377.8	3147	3	462.1	3180	3	544.1
3114	3	380.3	3148	3	464.6	3181	3	546.6
3115	3	382.8	3149	3	467.1	3182	3	549.1

**TABLE 6-10. CALIBRATION OF HIGH FREQUENCY OSCILLATOR
200Kc TO 1810Kc**

Frequency: 3200-3300 Kc					
Freq.	A	B	Freq.	A	B
3200	3	593.9	3234	3	678.6
3201	3	596.4	3235	3	681.1
3202	3	598.9	3236	3	683.6
3203	3	601.4	3237	3	686.1
3204	3	603.9	3238	3	688.6
3205	3	606.4	3239	3	691.1
3206	3	608.9			
3207	3	611.4	3240	3	693.6
3208	3	613.9	3241	3	696.1
3209	3	616.4	3242	3	698.6
			3243	3	701.1
3210	3	618.8	3244	3	703.5
3211	3	621.3	3245	3	706.0
3212	3	623.8	3246	3	708.5
3213	3	626.3	3247	3	711.0
3214	3	628.8	3248	3	713.5
3215	3	631.3	3249	3	716.0
3216	3	633.8			
3217	3	636.3	3250	3	718.5
3218	3	638.8	3251	3	721.0
3219	3	641.3	3252	3	723.5
			3253	3	726.0
3220	3	643.8	3254	3	728.5
3221	3	646.3	3255	3	731.0
3222	3	648.8	3256	3	733.5
3223	3	651.3	3257	3	736.0
3224	3	653.7	3258	3	738.5
3225	3	656.2	3259	3	741.0
3226	3	658.7	3260	3	743.5
3227	3	661.2	3261	3	746.0
3228	3	663.7	3262	3	748.5
3229	3	666.2	3263	3	751.0
			3264	3	753.5
3230	3	668.7	3265	3	756.0
3231	3	671.2	3266	3	758.5
3232	3	673.7	3267	3	761.0
3233	3	676.2			
			3300	3	843.0

Use check point at 3150 or 3300 Kc, whichever is nearer

Frequency: 3400-3500 Kc					
Freq.	A	B	Freq.	A	B
3400	3	1089.7	3434	3	1172.8
3401	3	1092.1	3435	3	1175.2
3402	3	1094.6	3436	3	1177.7
3403	3	1097.0	3437	3	1180.1
3404	3	1099.5	3438	3	1182.5
3405	3	1101.9	3439	3	1185.0
3406	3	1104.4			
3407	3	1106.8	3440	3	1187.4
3408	3	1109.2	3441	3	1189.8
3409	3	1111.7	3442	3	1192.3
			3443	3	1194.7
3410	3	1114.1	3444	3	1197.2
3411	3	1116.6	3445	3	1199.6
3412	3	1119.0	3446	3	1202.0
3413	3	1121.5	3447	3	1204.5
3414	3	1123.9	3448	3	1206.9
3415	3	1126.4	3449	3	1209.3
3416	3	1128.8			
3417	3	1131.3	3450	3	1211.8
3418	3	1133.7	3451	3	1214.2
3419	3	1136.1	3452	3	1216.7
			3453	3	1219.1
3420	3	1138.6	3454	3	1221.5
3421	3	1141.0	3455	3	1224.0
3422	3	1143.5	3456	3	1226.4
3423	3	1145.9	3457	3	1228.8
3424	3	1148.4	3458	3	1231.3
3425	3	1150.8	3459	3	1233.7
3426	3	1153.3			
3427	3	1155.7	3460	3	1236.1
3428	3	1158.1	3461	3	1238.6
3429	3	1160.6	3462	3	1241.0
			3463	3	1243.4
3430	3	1163.0	3464	3	1245.9
3431	3	1165.5	3465	3	1248.3
3432	3	1167.9	3466	3	1250.7
3433	3	1170.3	3467	3	1253.2
			3500	3	1333.7

Use check point at 3450 Kc

Frequency: 3300-3400 Kc					
Freq.	A	B	Freq.	A	B
3300	3	843.0	3334	3	927.1
3301	3	845.5	3335	3	929.6
3302	3	848.0	3336	3	932.1
3303	3	850.4	3337	3	934.6
3304	3	852.9	3338	3	937.0
3305	3	855.4	3339	3	939.5
3306	3	857.9			
3307	3	860.3	3340	3	942.0
3308	3	862.8	3341	3	944.4
3309	3	865.3	3342	3	946.9
			3343	3	949.4
3310	3	867.8	3344	3	951.9
3311	3	870.2	3345	3	954.3
3312	3	872.7	3346	3	956.8
3313	3	875.2	3347	3	959.3
3314	3	877.7	3348	3	961.7
3315	3	880.1	3349	3	964.2
3316	3	882.6			
3317	3	885.1	3350	3	966.6
3318	3	887.6	3351	3	969.1
3319	3	890.0	3352	3	971.6
			3353	3	974.0
3320	3	892.5	3354	3	976.5
3321	3	895.0	3355	3	978.9
3322	3	897.4	3356	3	981.4
3323	3	899.9	3357	3	983.9
3324	3	902.4	3358	3	986.3
3325	3	904.9	3359	3	988.8
3326	3	907.3			
3327	3	909.8	3360	3	991.2
3328	3	912.3	3361	3	993.7
3329	3	914.8	3362	3	996.2
			3363	3	998.6
3330	3	917.2	3364	3	1001.1
3331	3	919.7	3365	3	1003.6
3332	3	922.2	3366	3	1006.0
3333	3	924.7	3367	3	1008.5
			3400	3	1089.7

Use check point at 3300 or 3450 Kc, whichever is nearer

Frequency: 3500-3600 Kc					
Freq.	A	B	Freq.	A	B
3500	3	1333.7	3534	3	1416.7
3501	3	1336.2	3535	3	1419.1
3502	3	1338.6	3536	3	1421.6
3503	3	1341.0	3537	3	1424.0
3504	3	1343.5	3538	3	1426.5
3505	3	1345.9	3539	3	1428.9
3506	3	1348.4			
3507	3	1350.8	3540	3	1431.4
3508	3	1353.2	3541	3	1433.8
3509	3	1355.7	3542	3	1436.2
			3543	3	1438.7
3510	3	1358.1	3544	3	1441.1
3511	3	1360.6	3545	3	1443.5
3512	3	1363.0	3546	3	1446.0
3513	3	1365.4	3547	3	1448.4
3514	3	1367.9	3548	3	1450.8
3515	3	1370.3	3549	3	1453.3
3516	3	1372.7			
3517	3	1375.2	3550	3	1455.7
3518	3	1377.6	3551	3	1458.1
3519	3	1380.0	3552	3	1460.6
			3553	3	1463.0
3520	3	1382.5	3554	3	1465.4
3521	3	1384.9	3555	3	1467.9
3522	3	1387.3	3556	3	1470.3
3523	3	1389.8	3557	3	1472.8
3524	3	1392.2	3558	3	1475.3
			3559	3	1477.7
3525	3	1394.6			
3526	3	1397.1	3560	3	1480.2
3527	3	1399.5	3561	3	1482.6
3528	3	1402.0	3562	3	1485.1
3529	3	1404.4	3563	3	1487.5
			3564	3	1490.0
3530	3	1406.9	3565	3	1492.5
3531	3	1409.3	3566	3	1495.0
3532	3	1411.8	3567	3	1497.4
3533	3	1414.2			
			3600	3	1578.9

Use check point at 3450 or 3600 Kc, whichever is nearer

**TABLE 6-10. CALIBRATION OF HIGH FREQUENCY OSCILLATOR
2000KC TO 18100KC**

Frequency: 3600—3700 Kc

Freq.	A	B	Freq.	A	B	Freq.	A	B
3600	4	60.0	3634	4	129.5	3668	4	198.4
3601	4	62.0	3635	4	131.5	3669	4	200.4
3602	4	64.1	3636	4	133.5			
3603	4	66.1	3637	4	135.6	3670	4	202.5
3604	4	68.2	3638	4	137.6	3671	4	204.5
3605	4	70.2	3639	4	139.6	3672	4	206.5
3606	4	72.3				3673	4	208.5
3607	4	74.3	3640	4	141.7	3674	4	210.6
3608	4	76.4	3641	4	143.7	3675	4	212.6
3609	4	78.4	3642	4	145.7	3676	4	214.6
			3643	4	147.7	3677	4	216.6
3610	4	80.4	3644	4	149.8	3678	4	218.7
3611	4	82.5	3645	4	151.8	3679	4	220.7
3612	4	84.5	3646	4	153.8			
3613	4	86.6	3647	4	155.9	3680	4	222.7
3614	4	88.6	3648	4	157.9	3681	4	224.7
3615	4	90.7	3649	4	159.9	3682	4	226.8
3616	4	92.7				3683	4	228.8
3617	4	94.7	3650	4	161.9	3684	4	230.8
3618	4	96.8	3651	4	164.0	3685	4	232.8
3619	4	98.8	3652	4	166.0	3686	4	234.9
			3653	4	168.0	3687	4	236.9
3620	4	100.9	3654	4	170.0	3688	4	238.9
3621	4	102.9	3655	4	172.1	3689	4	240.9
3622	4	105.0	3656	4	174.1			
3623	4	107.0	3657	4	176.1	3690	4	243.0
3624	4	109.1	3658	4	178.1	3691	4	245.0
3625	4	111.1	3659	4	180.2	3692	4	247.0
3626	4	113.1				3693	4	249.1
3627	4	115.2	3660	4	182.2	3694	4	251.1
3628	4	117.2	3661	4	184.2	3695	4	253.1
3629	4	119.3	3662	4	186.2	3696	4	255.2
			3663	4	188.3	3697	4	257.2
3630	4	121.3	3664	4	190.3	3698	4	259.2
3631	4	123.4	3665	4	192.3	3699	4	261.3
3632	4	125.4	3666	4	194.3			
3633	4	127.4	3667	4	196.4	3700	4	263.3

Use check point at 3600 or 3750 Kc, whichever is nearer

Frequency: 3800—3900 Kc

Freq.	A	B	Freq.	A	B	Freq.	A	B
3800	4	467.4	3834	4	537.4	3868	4	607.4
3801	4	469.5	3835	4	539.4	3869	4	609.5
3802	4	471.5	3836	4	541.5			
3803	4	473.5	3837	4	543.6	3870	4	611.6
3804	4	475.6	3838	4	545.6	3871	4	613.6
3805	4	477.6	3839	4	547.7	3872	4	615.7
3806	4	479.7				3873	4	617.8
3807	4	481.7	3840	4	549.7	3874	4	619.8
3808	4	483.7	3841	4	551.8	3875	4	621.9
3809	4	485.8	3842	4	553.8	3876	4	623.9
			3843	4	555.9	3877	4	626.0
3810	4	487.8	3844	4	557.9	3878	4	628.1
3811	4	489.9	3845	4	560.0	3879	4	630.1
3812	4	492.0	3846	4	562.1			
3813	4	494.0	3847	4	564.1	3880	4	632.2
3814	4	496.1	3848	4	566.2	3881	4	634.3
3815	4	498.2	3849	4	568.2	3882	4	636.3
3816	4	500.2				3883	4	638.4
3817	4	502.3	3850	4	570.3	3884	4	640.4
3818	4	504.4	3851	4	572.3	3885	4	642.5
3819	4	506.5	3852	4	574.4	3886	4	644.6
			3853	4	576.5	3887	4	646.6
3820	4	508.5	3854	4	578.5	3888	4	648.7
3821	4	510.6	3855	4	580.6	3889	4	650.7
3822	4	512.7	3856	4	582.6			
3823	4	514.8	3857	4	584.7	3890	4	652.8
3824	4	516.8	3858	4	586.8	3891	4	654.9
3825	4	518.9	3859	4	588.8	3892	4	656.9
3826	4	521.0				3893	4	659.0
3827	4	523.0	3860	4	590.9	3894	4	661.1
3828	4	525.1	3861	4	593.0	3895	4	663.1
3829	4	527.1	3862	4	595.0	3896	4	665.2
			3863	4	597.1	3897	4	667.2
3830	4	529.2	3864	4	599.2	3898	4	669.3
3831	4	531.2	3865	4	601.2	3899	4	671.4
3832	4	533.3	3866	4	603.3			
3833	4	535.3	3867	4	605.4	3900	4	673.4

Use check point at 3750 or 3900 Kc, whichever is nearer

Frequency: 3700—3800 Kc

Freq.	A	B	Freq.	A	B	Freq.	A	B
3700	4	263.3	3734	4	332.4	3768	4	401.8
3701	4	265.4	3735	4	334.5	3769	4	403.8
3702	4	267.4	3736	4	336.5			
3703	4	269.4	3737	4	338.6	3770	4	405.9
3704	4	271.5	3738	4	340.6	3771	4	407.9
3705	4	273.5	3739	4	342.7	3772	4	410.0
3706	4	275.5				3773	4	412.0
3707	4	277.6	3740	4	344.7	3774	4	414.1
3708	4	279.6	3741	4	346.8	3775	4	416.1
3709	4	281.6	3742	4	348.8	3776	4	418.2
			3743	4	350.8	3777	4	420.2
3710	4	283.6	3744	4	352.9	3778	4	422.3
3711	4	285.7	3745	4	354.9	3779	4	424.3
3712	4	287.7	3746	4	357.0			
3713	4	289.7	3747	4	359.0	3780	4	426.4
3714	4	291.7	3748	4	361.1	3781	4	428.4
3715	4	293.8	3749	4	363.1	3782	4	430.5
3716	4	295.8				3783	4	432.6
3717	4	297.8	3750	4	365.2	3784	4	434.6
3718	4	299.8	3751	4	367.2	3785	4	436.7
3719	4	301.9	3752	4	369.2	3786	4	438.7
			3753	4	371.2	3787	4	440.8
3720	4	303.9	3754	4	373.3	3788	4	442.8
3721	4	305.9	3755	4	375.3	3789	4	444.9
3722	4	308.0	3756	4	377.3			
3723	4	310.0	3757	4	379.4	3790	4	447.0
3724	4	312.1	3758	4	381.4	3791	4	449.0
3725	4	314.1	3759	4	383.4	3792	4	451.1
3726	4	316.1				3793	4	453.1
3727	4	318.2	3760	4	385.5	3794	4	455.2
3728	4	320.2	3761	4	387.5	3795	4	457.2
3729	4	322.2	3762	4	389.5	3796	4	459.3
			3763	4	391.6	3797	4	461.3
3730	4	324.3	3764	4	393.6	3798	4	463.4
3731	4	326.3	3765	4	395.6	3799	4	465.4
3732	4	328.4	3766	4	397.7			
3733	4	330.4	3767	4	399.7	3800	4	467.4

Use check point at 3750 Kc

Frequency: 3900—4000 Kc

Freq.	A	B	Freq.	A	B	Freq.	A	B
3900	4	673.4	3934	4	743.4	3968	4	813.4
3901	4	675.5	3935	4	745.5	3969	4	815.5
3902	4	677.5	3936	4	747.5			
3903	4	679.6	3937	4	749.6	3970	4	817.6
3904	4	681.6	3938	4	751.6	3971	4	819.7
3905	4	683.7	3939	4	753.7	3972	4	821.7
3906	4	685.8				3973	4	823.8
3907	4	687.8	3940	4	755.7	3974	4	825.9
3908	4	689.9	3941	4	757.8	3975	4	828.0
3909	4	691.9	3942	4	759.8	3976	4	830.0
			3943	4	761.9	3977	4	832.1
3910	4	694.0	3944	4	763.9	3978	4	834.1
3911	4	696.0	3945	4	766.0	3979	4	836.2
3912	4	698.1	3946	4	768.0			
3913	4	700.1	3947	4	770.1	3980	4	838.2
3914	4	702.2	3948	4	772.1	3981	4	840.3
3915	4	704.2	3949	4	774.2	3982	4	842.3
3916	4	706.3				3983	4	844.4
3917	4	708.4	3950	4	776.3	3984	4	846.4
3918	4	710.4	3951	4	778.3	3985	4	848.5
3919	4	712.5	3952	4	780.4	3986	4	850.5
			3953	4	782.4	3987	4	852.6
3920	4	714.6	3954	4	784.5	3988	4	854.7
3921	4	716.6	3955	4	786.6	3989	4	856.7
3922	4	718.7	3956	4	788.6			
3923	4	720.8	3957	4	790.7	3990	4	858.8
3924	4	722.9	3958	4	792.7	3991	4	860.8
3925	4	724.9	3959	4	794.8	3992	4	862.8
3926	4	727.0				3993	4	864.8
3927	4	729.1	3960	4	796.9	3994	4	866.9
3928	4	731.1	3961	4	798.9	3995	4	868.9
3929	4	733.2	3962	4	801.0	3996	4	870.9
			3963	4	803.1	3997	4	872.9
3930	4	735.3	3964	4	805.2	3998	4	875.0
3931	4	737.3	3965	4	807.2	3999	4	877.0
3932	4	739.4	3966	4	809.3			
3933	4	741.4	3967	4	811.4	4000	4	879.0

Use check point at 3900 Kc

**TABLE 6-10. CALIBRATION OF HIGH FREQUENCY OSCILLATOR
200KC TO 1810KC**

Frequency: 4000-4100 Kc						Frequency: 4200-4300 Kc					
Freq.	A	B	Freq.	A	B	Freq.	A	B	Freq.	A	B
4000	5	100.1	4034	5	162.9	4068	5	225.4	4200	5	469.6
4001	5	102.0	4035	5	164.8	4069	5	227.2	4201	5	471.4
4002	5	103.8	4036	5	166.6				4202	5	473.3
4003	5	105.7	4037	5	168.5	4070	5	229.1	4203	5	475.2
4004	5	107.5	4038	5	170.3	4071	5	230.9	4204	5	477.0
4005	5	109.4	4039	5	172.1	4072	5	232.7	4205	5	478.9
4006	5	111.2				4073	5	234.6	4206	5	480.7
4007	5	113.1	4040	5	174.0	4074	5	236.4	4207	5	482.6
4008	5	114.9	4041	5	175.8	4075	5	238.3	4208	5	484.4
4009	5	116.8	4042	5	177.7	4076	5	240.1	4209	5	486.3
			4043	5	179.5	4077	5	241.9			
4010	5	118.6	4044	5	181.3	4078	5	243.8	4210	5	488.2
4011	5	120.5	4045	5	183.2	4079	5	245.6	4211	5	490.0
4012	5	122.3	4046	5	185.0				4212	5	491.9
4013	5	124.2	4047	5	186.8	4080	5	247.4	4213	5	493.7
4014	5	126.0	4048	5	188.7	4081	5	249.3	4214	5	495.6
4015	5	127.9	4049	5	190.5	4082	5	251.1	4215	5	497.4
4016	5	129.7				4083	5	253.0	4216	5	499.3
4017	5	131.6	4050	5	192.3	4084	5	254.8	4217	5	501.1
4018	5	133.4	4051	5	194.2	4085	5	256.7	4218	5	503.0
4019	5	135.3	4052	5	196.0	4086	5	258.5	4219	5	504.9
			4053	5	197.8	4087	5	260.3			
4020	5	137.1	4054	5	199.7	4088	5	262.2	4220	5	506.7
4021	5	139.0	4055	5	201.5	4089	5	264.0	4221	5	508.6
4022	5	140.8	4056	5	203.4				4222	5	510.5
4023	5	142.7	4057	5	205.2	4090	5	265.9	4223	5	512.3
4024	5	144.5	4058	5	207.0	4091	5	267.7	4224	5	514.2
4025	5	146.4	4059	5	208.9	4092	5	269.6	4225	5	516.1
4026	5	148.2				4093	5	271.4	4226	5	517.9
4027	5	150.0	4060	5	210.7	4094	5	273.2	4227	5	519.8
4028	5	151.9	4061	5	212.5	4095	5	275.1	4228	5	521.7
4029	5	153.7	4062	5	214.4	4096	5	276.9	4229	5	523.6
			4063	5	216.2	4097	5	278.8			
4030	5	155.6	4064	5	218.0	4098	5	280.6	4230	5	525.4
4031	5	157.4	4065	5	219.9	4099	5	282.5	4231	5	527.3
4032	5	159.2	4066	5	221.7				4232	5	529.2
4033	5	161.1	4067	5	223.6	4100	5	284.3	4233	5	531.0

Frequency: 4100-4200 Kc						Frequency: 4300-4400 Kc					
Freq.	A	B	Freq.	A	B	Freq.	A	B	Freq.	A	B
4100	5	284.3	4134	5	347.1	4168	5	410.0	4300	5	656.2
4101	5	286.1	4135	5	348.9	4169	5	411.8	4301	5	658.1
4102	5	288.0	4136	5	350.8				4302	5	660.0
4103	5	289.8	4137	5	352.6	4170	5	413.7	4303	5	661.8
4104	5	291.7	4138	5	354.5	4171	5	415.6	4304	5	663.7
4105	5	293.5	4139	5	356.3	4172	5	417.4	4305	5	665.6
4106	5	295.4				4173	5	419.3	4306	5	667.4
4107	5	297.2	4140	5	358.1	4174	5	421.2	4307	5	669.3
4108	5	299.1	4141	5	360.0	4175	5	423.0	4308	5	671.2
4109	5	300.9	4142	5	361.8	4176	5	424.9	4309	5	673.0
			4143	5	363.7	4177	5	426.7			
4110	5	302.8	4144	5	365.5	4178	5	428.6	4310	5	674.9
4111	5	304.6	4145	5	367.4	4179	5	430.5	4311	5	676.8
4112	5	306.5	4146	5	369.2				4312	5	678.6
4113	5	308.3	4147	5	371.1	4180	5	432.3	4313	5	680.5
4114	5	310.2	4148	5	372.9	4181	5	434.2	4314	5	682.4
4115	5	312.0	4149	5	374.8	4182	5	436.1	4315	5	684.2
4116	5	313.9				4183	5	437.9	4316	5	686.1
4117	5	315.7	4150	5	376.6	4184	5	439.8	4317	5	688.0
4118	5	317.5	4151	5	378.4	4185	5	441.7	4318	5	689.8
4119	5	319.4	4152	5	380.3	4186	5	443.5	4319	5	691.7
			4153	5	382.1	4187	5	445.4			
4120	5	321.2	4154	5	384.0	4188	5	447.2	4320	5	693.6
4121	5	323.1	4155	5	385.8	4189	5	449.1	4321	5	695.5
4122	5	324.9	4156	5	387.7				4322	5	697.3
4123	5	326.8	4157	5	389.5	4190	5	451.0	4323	5	699.2
4124	5	328.6	4158	5	391.4	4191	5	452.8	4324	5	701.1
4125	5	330.5	4159	5	393.2	4192	5	454.7	4325	5	702.9
4126	5	332.3				4193	5	456.5	4326	5	704.8
4127	5	334.2	4160	5	395.1	4194	5	458.4	4327	5	706.7
4128	5	336.0	4161	5	396.9	4195	5	460.3	4328	5	708.5
4129	5	337.8	4162	5	398.8	4196	5	462.1	4329	5	710.4
			4163	5	400.7	4197	5	464.0			
4130	5	339.7	4164	5	402.5	4198	5	465.9	4330	5	712.3
4131	5	341.5	4165	5	404.4	4199	5	467.7	4331	5	714.2
4132	5	343.4	4166	5	406.2				4332	5	716.0
4133	5	345.2	4167	5	408.1	4200	5	469.6	4333	5	717.9

Use check point at 4000 Kc

Use check point at 4200 Kc

Use check point at 4200 Kc

Use check point at 4400 Kc

**TABLE 6-10. CALIBRATION OF HIGH FREQUENCY OSCILLATOR
2000KC TO 18100KC**

Frequency: 4400-4500 Kc						Frequency: 4600-4700 Kc								
Freq.	A	B	Freq.	A	B	Freq.	A	B	Freq.	A	B	Freq.	A	B
4400	5	843.0	4434	5	906.1	4468	5	979.1	4600	5	1211.8	4634	5	1273.9
4401	5	844.9	4435	5	908.0	4469	5	970.9	4601	5	1213.6	4635	5	1275.7
4402	5	846.7	4436	5	909.8				4602	5	1215.4	4636	5	1277.5
4403	5	848.6	4437	5	911.7	4470	5	972.8	4603	5	1217.3	4637	5	1279.4
4404	5	850.4	4438	5	913.5	4471	5	974.6	4604	5	1219.1	4638	5	1281.2
4405	5	852.3	4439	5	915.4	4472	5	976.5	4605	5	1220.9	4639	5	1283.0
4406	5	854.1				4473	5	978.3	4606	5	1222.7			
4407	5	856.0	4440	5	917.2	4474	5	980.2	4607	5	1224.6	4640	5	1284.8
4408	5	857.8	4441	5	919.1	4475	5	982.0	4608	5	1226.4	4641	5	1286.7
4409	5	859.7	4442	5	921.0	4476	5	983.9	4609	5	1228.2	4642	5	1288.5
			4443	5	922.8	4477	5	985.7				4643	5	1290.3
4410	5	861.6	4444	5	924.7	4478	5	987.6	4610	5	1230.0	4644	5	1292.2
4411	5	863.4	4445	5	926.5	4479	5	989.4	4611	5	1231.9	4645	5	1294.0
4412	5	865.3	4446	5	928.4				4612	5	1233.7	4646	5	1295.8
4413	5	867.1	4447	5	930.2	4480	5	991.2	4613	5	1235.5	4647	5	1297.7
4414	5	869.0	4448	5	932.1	4481	5	993.1	4614	5	1237.3	4648	5	1299.5
4415	5	870.8	4449	5	933.9	4482	5	994.9	4615	5	1239.2	4649	5	1301.3
4416	5	872.7				4483	5	996.8	4616	5	1241.0			
4417	5	874.6	4450	5	935.8	4484	5	998.6	4617	5	1242.8	4650	5	1303.2
4418	5	876.4	4451	5	937.6	4485	5	1000.5	4618	5	1244.6	4651	5	1305.0
4419	5	878.3	4452	5	939.5	4486	5	1002.3	4619	5	1246.5	4652	5	1306.8
			4453	5	941.4	4487	5	1004.2				4653	5	1308.7
4420	5	880.1	4454	5	943.2	4488	5	1006.0	4620	5	1248.3	4654	5	1310.5
4421	5	882.0	4455	5	945.1	4489	5	1007.9	4621	5	1250.1	4655	5	1312.4
4422	5	883.8	4456	5	946.9				4622	5	1252.0	4656	5	1314.2
4423	5	885.7	4457	5	948.8	4490	5	1009.7	4623	5	1253.8	4657	5	1316.0
4424	5	887.5	4458	5	950.6	4491	5	1011.6	4624	5	1255.6	4658	5	1317.9
4425	5	889.4	4459	5	952.5	4492	5	1013.5	4625	5	1257.4	4659	5	1319.7
4426	5	891.3				4493	5	1015.3	4626	5	1259.3			
4427	5	893.1	4460	5	954.3	4494	5	1017.2	4627	5	1261.1	4660	5	1321.5
4428	5	895.0	4461	5	956.2	4495	5	1019.0	4628	5	1262.9	4661	5	1323.4
4429	5	896.8	4462	5	958.0	4496	5	1020.9	4629	5	1264.7	4662	5	1325.2
			4463	5	959.9	4497	5	1022.7				4663	5	1327.0
4430	5	898.7	4464	5	961.7	4498	5	1024.6	4630	5	1266.6	4664	5	1328.8
4431	5	900.5	4465	5	963.6	4499	5	1026.4	4631	5	1268.4	4665	5	1330.7
4432	5	902.4	4466	5	965.4				4632	5	1270.2	4666	5	1332.5
4433	5	904.2	4467	5	967.3	4500	5	1028.3	4633	5	1272.1	4667	5	1334.3

Frequency: 4500-4600 Kc						Frequency: 4700-4800 Kc								
Freq.	A	B	Freq.	A	B	Freq.	A	B	Freq.	A	B	Freq.	A	B
4500	5	1028.3	4534	5	1090.9	4568	5	1153.3	4700	5	1394.6	4734	5	1456.9
4501	5	1030.1	4535	5	1092.7	4569	5	1155.1	4701	5	1396.5	4735	5	1458.7
4502	5	1032.0	4536	5	1094.6				4702	5	1398.3	4736	5	1460.6
4503	5	1033.8	4537	5	1096.4	4570	5	1156.9	4703	5	1400.1	4737	5	1462.4
4504	5	1035.7	4538	5	1098.2	4571	5	1158.8	4704	5	1402.0	4738	5	1464.2
4505	5	1037.5	4539	5	1100.1	4572	5	1160.6	4705	5	1403.8	4739	5	1466.0
4506	5	1039.4				4573	5	1162.4	4706	5	1405.7			
4507	5	1041.2	4540	5	1101.9	4574	5	1164.2	4707	5	1407.5	4740	5	1467.9
4508	5	1043.1	4541	5	1103.7	4575	5	1166.1	4708	5	1409.3	4741	5	1469.7
4509	5	1044.9	4542	5	1105.6	4576	5	1167.9	4709	5	1411.2	4742	5	1471.6
			4543	5	1107.4	4577	5	1169.7				4743	5	1473.4
4510	5	1046.8	4544	5	1109.3	4578	5	1171.6	4710	5	1413.0	4744	5	1475.3
4511	5	1048.6	4545	5	1111.1	4579	5	1173.4	4711	5	1414.8	4745	5	1477.1
4512	5	1050.5	4546	5	1112.9				4712	5	1416.7	4746	5	1479.0
4513	5	1052.3	4547	5	1114.8	4580	5	1175.2	4713	5	1418.5	4747	5	1480.8
4514	5	1054.2	4548	5	1116.6	4581	5	1177.1	4714	5	1420.3	4748	5	1482.7
4515	5	1056.0	4549	5	1118.4	4582	5	1178.9	4715	5	1422.2	4749	5	1484.5
4516	5	1057.9				4583	5	1180.7	4716	5	1424.0			
4517	5	1059.7	4550	5	1120.3	4584	5	1182.5	4717	5	1425.9	4750	5	1486.4
4518	5	1061.6	4551	5	1122.1	4585	5	1184.4	4718	5	1427.7	4751	5	1488.2
4519	5	1063.4	4552	5	1123.9	4586	5	1186.2	4719	5	1429.5	4752	5	1490.0
			4553	5	1125.8	4587	5	1188.0				4753	5	1491.9
4520	5	1065.3	4554	5	1127.6	4588	5	1189.9	4720	5	1431.4	4754	5	1493.7
4521	5	1067.1	4555	5	1129.4	4589	5	1191.7	4721	5	1433.2	4755	5	1495.6
4522	5	1068.9	4556	5	1131.3				4722	5	1435.0	4756	5	1497.4
4523	5	1070.8	4557	5	1133.1	4590	5	1193.5	4723	5	1436.8	4757	5	1499.3
4524	5	1072.6	4558	5	1134.9	4591	5	1195.3	4724	5	1438.7	4758	5	1501.1
4525	5	1074.4	4559	5	1136.8	4592	5	1197.2	4725	5	1440.5	4759	5	1503.0
4526	5	1076.3				4593	5	1199.0	4726	5	1442.3			
4527	5	1078.1	4560	5	1138.6	4594	5	1200.8	4727	5	1444.1	4760	5	1504.8
4528	5	1079.9	4561	5	1140.4	4595	5	1202.6	4728	5	1446.0	4761	5	1506.7
4529	5	1081.8	4562	5	1142.3	4596	5	1204.5	4729	5	1447.8	4762	5	1508.5
			4563	5	1144.1	4597	5	1206.3				4763	5	1510.4
4530	5	1083.6	4564	5	1145.9	4598	5	1208.1	4730	5	1449.6	4764	5	1512.2
4531	5	1085.4	4565	5	1147.8	4599	5	1210.0	4731	5	1451.4	4765	5	1514.1
4532	5	1087.3	4566	5	1149.6				4732	5	1453.3	4766	5	1515.9
4533	5	1089.1	4567	5	1151.4	4600	5	1211.8	4733	5	1455.1	4767	5	1517.7

Use check point at 4400 Kc

Use check point at 4600 Kc

Use check point at 4500 Kc

Use check point at 4800 Kc

**TABLE 6-10. CALIBRATION OF HIGH FREQUENCY OSCILLATOR
2000Kc TO 18100Kc**

Frequency: 4800-4900 Kc

Freq.	A	B	Freq.	A	B	Freq.	A	B
4800	6	60.0	4834	6	112.1	4868	6	164.0
4801	6	61.5	4835	6	113.7	4869	6	165.5
4802	6	63.1	4836	6	115.2			
4803	6	64.6	4837	6	116.7	4870	6	167.0
4804	6	66.1	4838	6	118.3	4871	6	168.5
4805	6	67.7	4839	6	119.8	4872	6	170.0
4806	6	69.2				4873	6	171.6
4807	6	70.7	4840	6	121.3	4874	6	173.1
4808	6	72.3	4841	6	122.8	4875	6	174.6
4809	6	73.8	4842	6	124.4	4876	6	176.1
			4843	6	125.9	4877	6	177.6
4810	6	75.3	4844	6	127.4	4878	6	179.1
4811	6	76.9	4845	6	128.9	4879	6	180.7
4812	6	78.4	4846	6	130.5			
4813	6	79.9	4847	6	132.0	4880	6	182.2
4814	6	81.5	4848	6	133.5	4881	6	183.7
4815	6	83.0	4849	6	135.0	4882	6	185.2
4816	6	84.5				4883	6	186.7
4817	6	86.1	4850	6	136.6	4884	6	188.3
4818	6	87.6	4851	6	138.1	4885	6	189.8
4819	6	89.1	4852	6	139.6	4886	6	191.3
			4853	6	141.1	4887	6	192.8
4820	6	90.7	4854	6	142.7	4888	6	194.3
4821	6	92.2	4855	6	144.2	4889	6	195.9
4822	6	93.7	4856	6	145.7			
4823	6	95.3	4857	6	147.2	4890	6	197.4
4824	6	96.8	4858	6	148.8	4891	6	198.9
4825	6	98.3	4859	6	150.3	4892	6	200.4
4826	6	99.9				4893	6	202.0
4827	6	101.4	4860	6	151.8	4894	6	203.5
4828	6	102.9	4861	6	153.3	4895	6	205.0
4829	6	104.5	4862	6	154.9	4896	5	206.5
			4863	6	156.4	4897	6	208.0
4830	6	106.0	4864	6	157.9	4898	6	209.6
4831	6	107.5	4865	6	159.4	4899	6	211.1
4832	6	109.1	4866	6	160.9			
4833	6	110.6	4867	6	162.4	4900	6	212.6

Use check point at 4800 Kc

Frequency: 5000-5100 Kc

Freq.	A	B	Freq.	A	B	Freq.	A	B
5000	6	365.2	5034	6	417.2	5068	6	469.5
5001	6	366.7	5035	6	418.7	5069	6	471.0
5002	6	368.2	5036	6	420.2			
5003	6	369.7	5037	6	421.8	5070	6	472.5
5004	6	371.3	5038	6	423.3	5071	6	474.1
5005	6	372.8	5039	6	424.8	5072	6	475.6
5006	6	374.3				5073	6	477.1
5007	6	375.8	5040	6	426.4	5074	6	478.6
5008	6	377.3	5041	6	427.9	5075	6	480.2
5009	6	378.9	5042	6	429.5	5076	6	481.7
			5043	6	431.0	5077	6	483.2
5010	6	380.4	5044	6	432.6	5078	6	484.8
5011	6	381.9	5045	6	434.1	5079	6	486.3
5012	6	383.4	5046	6	435.6			
5013	6	385.0	5047	6	437.2	5080	6	487.8
5014	6	386.5	5048	6	438.7	5081	6	489.4
5015	6	388.0	5049	6	440.3	5082	6	490.9
5016	6	389.5				5083	6	492.5
5017	6	391.1	5050	6	441.8	5084	6	494.0
5018	6	392.6	5051	6	443.4	5085	6	495.6
5019	6	394.1	5052	6	444.9	5086	6	497.2
			5053	6	446.4	5087	6	498.7
5020	6	395.6	5054	6	448.0	5088	6	500.3
5021	6	397.2	5055	6	449.5	5089	6	501.8
5022	6	398.7	5056	6	451.1			
5023	6	400.2	5057	6	452.6	5090	6	503.4
5024	6	401.8	5058	6	454.2	5091	6	504.9
5025	6	403.3	5059	6	455.7	5092	6	506.5
5026	6	404.8				5093	6	508.0
5027	6	406.4	5060	6	457.2	5094	6	509.6
5028	6	407.9	5061	6	458.8	5095	6	511.1
5029	6	409.5	5062	6	460.3	5096	6	512.7
			5063	6	461.8	5097	6	514.3
5030	6	411.0	5064	6	463.4	5098	6	515.8
5031	6	412.5	5065	6	464.9	5099	6	517.4
5032	6	414.1	5066	6	466.4			
5033	6	415.6	5067	6	467.9	5100	6	518.9

Use check point at 5000 Kc

Frequency: 4900-5000 Kc

Freq.	A	B	Freq.	A	B	Freq.	A	B
4900	6	212.6	4934	6	264.3	4968	6	316.1
4901	6	214.1	4935	6	265.9	4969	6	317.7
4902	6	215.6	4936	6	267.4			
4903	6	217.2	4937	6	268.9	4970	6	319.2
4904	6	218.7	4938	6	270.4	4971	6	320.7
4905	6	220.2	4939	6	272.0	4972	6	322.2
4906	6	221.7				4973	6	323.8
4907	6	223.2	4940	6	273.5	4974	6	325.3
4908	6	224.7	4941	6	275.0	4975	6	326.8
4909	6	226.3	4942	6	276.5	4976	6	328.4
			4943	6	278.1	4977	6	329.9
4910	6	227.8	4944	6	279.6	4978	6	331.4
4911	6	229.3	4945	6	281.1	4979	6	333.0
4912	6	230.8	4946	6	282.6			
4913	6	232.3	4947	6	284.1	4980	6	334.5
4914	6	233.9	4948	6	285.7	4981	6	336.0
4915	6	235.4	4949	6	287.2	4982	6	337.5
4916	6	236.9				4983	6	339.1
4917	6	238.4	4950	6	288.7	4984	6	340.6
4918	6	239.9	4951	6	290.2	4985	6	342.2
4919	6	241.4	4952	6	291.7	4986	6	343.7
			4953	6	293.3	4987	6	345.2
4920	6	243.0	4954	6	294.8	4988	6	346.8
4921	6	244.5	4955	6	296.3	4989	6	348.3
4922	6	246.0	4956	6	297.8			
4923	6	247.5	4957	5	299.3	4990	6	349.8
4924	6	249.1	4958	6	300.9	4991	6	351.4
4925	6	250.6	4959	6	302.4	4992	6	352.9
4926	6	252.1				4993	6	354.4
4927	6	253.6	4960	6	303.9	4994	6	356.0
4928	6	255.2	4961	6	305.4	4995	6	357.5
4929	6	256.7	4962	6	307.0	4996	6	359.0
			4963	6	308.5	4997	6	360.6
4930	6	258.2	4964	6	310.0	4998	6	362.1
4931	6	259.8	4965	6	311.5	4999	6	363.6
4932	6	261.3	4966	6	313.1			
4933	6	262.8	4967	6	314.6	5000	6	365.2

Use check point at 5000 Kc

Frequency: 5100-5200 Kc

Freq.	A	B	Freq.	A	B	Freq.	A	B
5100	6	518.9	5134	6	571.3	5168	6	623.9
5101	6	520.5	5135	6	572.9	5169	6	625.5
5102	6	522.0	5136	6	574.4			
5103	6	523.5	5137	6	576.0	5170	6	627.0
5104	6	525.1	5138	6	577.5	5171	6	628.6
5105	6	526.6	5139	6	579.0	5172	6	630.1
5106	6	528.2				5173	6	631.7
5107	6	529.7	5140	6	580.6	5174	6	633.2
5108	6	531.2	5141	6	582.1	5175	6	634.8
5109	6	532.8	5142	6	583.7	5176	6	636.3
			5143	6	585.2	5177	6	637.9
5110	6	534.3	5144	6	586.8	5178	6	639.4
5111	6	535.9	5145	6	588.3	5179	6	641.0
5112	6	537.4	5146	6	589.9			
5113	6	538.9	5147	6	591.4	5180	6	642.5
5114	6	540.5	5148	6	593.0	5181	6	644.0
5115	6	542.0	5149	6	594.5	5182	6	645.6
5116	6	543.6				5183	6	647.1
5117	6	545.1	5150	6	596.1	5184	6	648.7
5118	6	546.6	5151	6	597.6	5185	6	650.2
5119	6	548.2	5152	6	599.2	5186	6	651.8
			5153	6	600.7	5187	6	653.3
5120	6	549.7	5154	6	602.3	5188	6	654.9
5121	6	551.3	5155	6	603.8	5189	6	656.4
5122	6	552.8	5156	6	605.4			
5123	6	554.3	5157	6	606.9	5190	6	658.0
5124	6	555.9	5158	6	608.5	5191	6	659.5
5125	6	557.4	5159	6	610.0	5192	6	661.1
5126	6	559.0				5193	6	662.6
5127	6	560.5	5160	6	611.6	5194	6	664.1
5128	6	562.1	5161	6	613.1	5195	6	665.7
5129	6	563.6	5162	6	614.7	5196	6	667.2
			5163	6	616.2	5197	6	668.8
5130	6	565.2	5164	6	617.8	5198	6	670.3
5131	6	566.7	5165	6	619.3	5199	6	671.9
5132	6	568.2	5166	6	620.9			
5133	6	569.8	5167	6	622.4	5200	6	673.4

Use check point at 5200 Kc

**TABLE 6-10. CALIBRATION OF HIGH FREQUENCY OSCILLATOR
2000Kc TO 18100Kc**

Frequency: 5200-5300 Kc

Freq.	A	B	Freq.	A	B	Freq.	A	B
5200	6	673.4	5234	6	726.0	5268	6	778.3
5201	6	675.0	5235	6	727.5	5269	6	779.9
5202	6	676.5	5236	6	729.1			
5203	6	678.0	5237	6	730.6	5270	6	781.4
5204	6	679.6	5238	6	732.2	5271	6	783.0
5205	6	681.1	5239	6	733.7	5272	6	784.5
5206	6	682.7				5273	6	786.0
5207	6	684.2	5240	6	735.3	5274	6	787.6
5208	6	685.7	5241	6	736.8	5275	6	789.1
5209	6	687.3	5242	6	738.3	5276	6	790.7
			5243	6	739.9	5277	6	792.2
5210	6	688.8	5244	6	741.4	5278	6	793.8
5211	6	690.4	5245	6	742.9	5279	6	795.3
5212	6	691.9	5246	6	744.5			
5213	6	693.5	5247	6	746.0	5280	6	796.9
5214	6	695.0	5248	6	747.5	5281	6	798.4
5215	6	696.5	5249	6	749.1	5282	6	800.0
5216	6	698.1				5283	6	801.5
5217	6	699.6	5250	6	750.6	5284	6	803.1
5218	6	701.2	5251	6	752.1	5285	6	804.6
5219	6	702.7	5252	6	753.7	5286	5	806.2
			5253	6	755.2	5287	5	807.7
5220	6	704.2	5254	6	756.8	5288	6	809.3
5221	6	705.8	5255	6	758.3	5289	6	810.9
5222	6	707.3	5256	6	759.8			
5223	6	708.9	5257	6	761.4	5290	6	812.4
5224	6	710.4	5258	6	762.9	5291	6	814.0
5225	6	712.0	5259	6	764.4	5292	6	815.5
5226	6	713.5				5293	6	817.1
5227	6	715.1	5260	6	766.0	5294	6	818.6
5228	6	716.6	5261	6	767.5	5295	6	820.2
5229	6	718.2	5262	6	769.1	5296	6	821.7
			5263	6	770.6	5297	6	823.3
5230	6	719.8	5264	6	772.1	5298	6	824.9
5231	6	721.3	5265	6	773.7	5299	6	826.4
5232	6	722.9	5266	6	775.2			
5233	6	724.4	5267	6	776.8	5300	6	828.0

Use check point at 5200 Kc

Frequency: 5400-5500 Kc

Freq.	A	B	Freq.	A	B	Freq.	A	B
5400	6	981.4	5434	6	1033.3	5468	6	1085.2
5401	6	982.9	5435	6	1034.9	5469	6	1086.7
5402	6	984.4	5436	6	1036.4			
5403	6	986.0	5437	6	1037.9	5470	6	1088.2
5404	6	987.5	5438	6	1039.4	5471	6	1089.7
5405	6	989.0	5439	6	1041.0	5472	6	1091.3
5406	6	990.5				5473	6	1092.8
5407	6	992.1	5440	6	1042.5	5474	6	1094.3
5408	6	993.6	5441	6	1044.0	5475	6	1095.8
5409	6	995.1	5442	6	1045.5	5476	6	1097.3
			5443	6	1047.1	5477	6	1098.9
5410	6	996.7	5444	6	1048.6	5478	6	1100.4
5411	6	998.2	5445	6	1050.1	5479	6	1101.9
5412	6	999.7	5446	6	1051.6			
5413	6	1001.3	5447	6	1053.2	5480	6	1103.4
5414	6	1002.8	5448	6	1054.7	5481	6	1105.0
5415	6	1004.3	5449	6	1056.2	5482	6	1106.5
5416	6	1005.8				5483	6	1108.0
5417	6	1007.4	5450	6	1057.7	5484	6	1109.5
5418	6	1008.9	5451	6	1059.3	5485	6	1111.0
5419	6	1010.4	5452	6	1060.8	5486	6	1112.6
			5453	6	1062.3	5487	6	1114.1
5420	6	1012.0	5454	6	1063.8	5488	6	1115.6
5421	6	1013.5	5455	6	1065.4	5489	6	1117.1
5422	6	1015.0	5456	6	1066.9			
5423	6	1016.5	5457	6	1068.4	5490	6	1118.6
5424	6	1018.1	5458	6	1069.9	5491	6	1120.2
5425	6	1019.6	5459	6	1071.5	5492	6	1121.7
5426	6	1021.1				5493	6	1123.2
5427	6	1022.6	5460	6	1073.0	5494	6	1124.7
5428	6	1024.2	5461	6	1074.5	5495	6	1126.2
5429	6	1025.7	5462	6	1076.0	5496	6	1127.8
			5463	6	1077.5	5497	6	1129.3
5430	6	1027.2	5464	6	1079.1	5498	6	1130.8
5431	6	1028.7	5465	6	1080.6	5499	6	1132.3
5432	6	1030.3	5466	6	1082.1			
5433	6	1031.8	5467	6	1083.6	5500	6	1133.8

Use check point at 5400 Kc

Frequency: 5300-5400 Kc

Freq.	A	B	Freq.	A	B	Freq.	A	B
5300	6	828.0	5334	6	880.0	5368	6	932.3
5301	6	829.5	5335	6	881.5	5369	6	933.8
5302	6	831.0	5336	6	883.1			
5303	6	832.6	5337	6	884.6	5370	6	935.3
5304	6	834.1	5338	6	886.1	5371	6	936.9
5305	6	835.7	5339	6	887.6	5372	6	938.4
5306	6	837.2				5373	6	939.9
5307	6	838.7	5340	6	889.1	5374	6	941.5
5308	6	840.3	5341	6	890.7	5375	6	943.0
5309	6	841.8	5342	6	892.2	5376	6	944.5
			5343	6	893.8	5377	6	946.1
5310	6	843.4	5344	6	895.3	5378	6	947.6
5311	6	844.9	5345	6	896.9	5379	6	949.1
5312	6	846.4	5346	6	898.4			
5313	6	848.0	5347	6	899.9	5380	6	950.7
5314	6	849.5	5348	6	901.5	5381	6	952.2
5315	6	851.1	5349	6	903.0	5382	6	953.7
5316	6	852.6				5383	6	955.3
5317	6	854.1	5350	6	904.6	5384	6	956.8
5318	6	855.7	5351	6	906.1	5385	6	958.3
5319	6	857.2	5352	6	907.7	5386	6	959.9
			5353	6	909.2	5387	6	961.4
5320	6	858.8	5354	6	910.8	5388	6	962.9
5321	6	860.3	5355	6	912.3	5389	6	964.5
5322	6	861.8	5356	6	913.8			
5323	6	863.3	5357	6	915.4	5390	6	966.0
5324	6	864.8	5358	6	916.9	5391	6	967.5
5325	6	866.4	5359	6	918.5	5392	6	969.1
5326	6	867.9				5393	6	970.6
5327	6	869.4	5360	6	920.0	5394	6	972.2
5328	6	870.9	5361	6	921.6	5395	6	973.7
5329	6	872.4	5362	6	923.1	5396	6	975.2
			5363	6	924.6	5397	6	976.8
5330	6	874.0	5364	6	926.1	5398	6	978.3
5331	6	875.5	5365	6	927.7	5399	6	979.8
5332	6	877.0	5366	6	929.2			
5333	6	878.5	5367	6	930.7	5400	6	981.4

Use check point at 5400 Kc

Frequency: 5500-5600 Kc

Freq.	A	B	Freq.	A	B	Freq.	A	B
5500	6	1133.8	5534	6	1185.4	5568	6	1237.0
5501	6	1135.4	5535	6	1186.9	5569	6	1238.5
5502	6	1136.9	5536	6	1188.4			
5503	6	1138.4	5537	6	1189.9	5570	6	1240.0
5504	6	1139.9	5538	6	1191.4	5571	6	1241.5
5505	6	1141.4	5539	6	1192.9	5572	6	1243.0
5506	6	1143.0				5573	6	1244.5
5507	6	1144.5	5540	6	1194.4	5574	6	1246.0
5508	6	1146.0	5541	6	1196.0	5575	6	1247.6
5509	6	1147.5	5542	6	1197.5	5576	6	1249.1
			5543	6	1199.0	5577	6	1250.6
5510	6	1149.0	5544	6	1200.5	5578	6	1252.1
5511	6	1150.5	5545	6	1202.1	5579	6	1253.6
5512	6	1152.1	5546	6	1203.6			
5513	6	1153.6	5547	6	1205.1	5580	6	1255.1
5514	6	1155.1	5548	6	1206.6	5581	6	1256.6
5515	6	1156.6	5549	6	1208.1	5582	6	1258.1
5516	6	1158.1				5583	6	1259.6
5517	6	1159.7	5550	6	1209.7	5584		

**TABLE 6-10. CALIBRATION OF HIGH FREQUENCY OSCILLATOR
2000KC TO 18100KC**

Frequency: 5600-5700 Kc

Freq.	A	B	Freq.	A	B	Freq.	A	B
5600	6	1285.3	5634	6	1336.9	5668	6	1388.4
5601	6	1286.8	5635	6	1338.4	5669	6	1389.9
5602	6	1288.3	5636	6	1339.9			
5603	6	1289.9	5637	6	1341.4	5670	6	1391.4
5604	6	1291.4	5638	6	1342.9	5671	6	1393.0
5605	6	1292.9	5639	6	1344.4	5672	6	1394.5
5606	6	1294.4				5673	6	1396.0
5607	6	1295.9	5640	6	1346.0	5674	6	1397.5
5608	6	1297.4	5641	6	1347.5	5675	6	1399.0
5609	6	1299.0	5642	6	1349.0	5676	6	1400.5
			5643	6	1350.5	5677	6	1402.1
			5644	6	1352.0	5678	6	1403.6
5610	6	1300.5	5645	6	1353.5	5679	6	1405.1
5611	6	1302.0	5646	6	1355.1			
5612	6	1303.5	5647	6	1356.6	5680	6	1406.6
5613	6	1305.0	5648	6	1358.1	5681	6	1408.1
5614	6	1306.6	5649	6	1359.6	5682	6	1409.6
5615	6	1308.1				5683	6	1411.2
5616	6	1309.6				5684	6	1412.7
5617	6	1311.1	5650	6	1361.1	5685	6	1414.2
5618	6	1312.6	5651	6	1362.6	5686	6	1415.7
5619	6	1314.1	5652	6	1364.2	5687	6	1417.3
			5653	6	1365.7	5688	6	1418.8
5620	6	1315.7	5654	6	1367.2	5689	6	1420.3
5621	6	1317.2	5655	6	1368.7			
5622	6	1318.7	5656	6	1370.2	5690	6	1421.8
5623	6	1320.2	5657	6	1371.7	5691	6	1423.4
5624	6	1321.7	5658	6	1373.2	5692	6	1424.9
5625	6	1323.2	5659	6	1374.8	5693	6	1426.4
5626	6	1324.8				5694	6	1427.9
5627	6	1326.3	5660	6	1376.3	5695	6	1429.4
5628	6	1327.8	5661	6	1377.8	5696	6	1431.0
5629	6	1329.3	5662	6	1379.3	5697	6	1432.5
			5663	6	1380.8	5698	6	1434.0
5630	6	1330.8	5664	6	1382.3	5699	6	1435.5
5631	6	1332.3	5665	6	1383.9			
5632	6	1333.8	5666	6	1385.4	5700	6	1437.1
5633	6	1335.4	5667	6	1386.9			

Use check point at 5600 Kc

Frequency: 5800-5900 Kc

Freq.	A	B	Freq.	A	B	Freq.	A	B
5800	6	1590.1	5834	6	1642.9	5868	6	1696.2
5801	6	1591.6	5835	6	1644.5	5869	6	1697.8
5802	6	1593.2	5836	6	1646.0			
5803	6	1594.7	5837	6	1647.6	5870	6	1699.3
5804	6	1596.3	5838	6	1649.1	5871	6	1700.9
5805	6	1597.8	5839	6	1650.7	5872	6	1702.5
5806	6	1599.4				5873	6	1704.1
5807	6	1600.9	5840	6	1652.3	5874	6	1705.7
5808	6	1602.5	5841	6	1653.8	5875	6	1707.2
5809	6	1604.0	5842	6	1655.4	5876	6	1708.8
			5843	6	1657.0	5877	6	1710.4
5810	6	1605.6	5844	6	1658.5	5878	6	1712.0
5811	6	1607.1	5845	6	1660.1	5879	6	1713.5
5812	6	1608.7	5846	6	1661.7			
5813	6	1610.2	5847	6	1663.2	5880	6	1715.1
5814	6	1611.8	5848	6	1664.8	5881	6	1716.7
5815	6	1613.3	5849	6	1666.3	5882	6	1718.3
5816	6	1614.9				5883	6	1719.9
5817	6	1616.4	5850	6	1667.9	5884	6	1721.5
5818	6	1618.0	5851	6	1669.5	5885	6	1723.0
5819	6	1619.5	5852	6	1671.0	5886	6	1724.6
			5853	6	1672.6	5887	6	1726.2
5820	6	1621.1	5854	6	1674.2	5888	6	1727.8
5821	6	1622.6	5855	6	1675.7	5889	6	1729.4
5822	6	1624.2	5856	6	1677.3			
5823	6	1625.7	5857	6	1678.9	5890	6	1731.0
5824	6	1627.3	5858	6	1680.4	5891	6	1732.5
5825	6	1628.9	5859	6	1682.0	5892	6	1734.1
5826	6	1630.4				5893	6	1735.7
5827	6	1632.0	5860	6	1683.6	5894	6	1737.3
5828	6	1633.5	5861	6	1685.1	5895	6	1738.9
5829	6	1635.1	5862	6	1686.7	5896	6	1740.5
			5863	6	1688.3	5897	6	1742.0
5830	6	1636.7	5864	6	1689.9	5898	6	1743.6
5831	6	1638.2	5865	6	1691.5	5899	6	1745.2
5832	6	1639.8	5866	6	1693.0			
5833	6	1641.3	5867	6	1694.6	5900	6	1746.8

Use check point at 5800 Kc

Frequency: 5700-5800 Kc

Freq.	A	B	Freq.	A	B	Freq.	A	B
5700	6	1437.1	5734	6	1488.9	5768	6	1540.9
5701	6	1438.6	5735	6	1490.4	5769	6	1542.5
5702	6	1440.1	5736	6	1491.9			
5703	6	1441.6	5737	6	1493.5	5770	6	1544.0
5704	6	1443.2	5738	6	1495.0	5771	6	1545.5
5705	6	1444.7	5739	6	1496.5	5772	6	1547.0
5706	6	1446.2				5773	6	1548.6
5707	6	1447.8	5740	6	1498.0	5774	6	1550.1
5708	6	1449.3	5741	6	1499.6	5775	6	1551.6
5709	6	1450.8	5742	6	1501.1	5776	6	1553.2
			5743	6	1502.6	5777	6	1554.7
5710	6	1452.4	5744	6	1504.2	5778	6	1556.2
5711	6	1453.9	5745	6	1505.7	5779	6	1557.8
5712	6	1455.4	5746	6	1507.2			
5713	6	1456.9	5747	6	1508.8	5780	6	1559.3
5714	6	1458.5	5748	6	1510.3	5781	6	1560.8
5715	6	1460.0	5749	6	1511.8	5782	6	1562.4
5716	6	1461.5				5783	6	1563.9
5717	6	1463.1	5750	6	1513.4	5784	6	1565.4
5718	6	1464.6	5751	6	1514.9	5785	6	1567.0
5719	6	1466.1	5752	6	1516.4	5786	6	1568.5
			5753	6	1517.9	5787	6	1570.1
5720	6	1467.6	5754	6	1519.5	5788	6	1571.6
5721	6	1469.2	5755	6	1521.0	5789	6	1573.1
5722	6	1470.7	5756	6	1522.5			
5723	6	1472.2	5757	6	1524.1	5790	6	1574.7
5724	6	1473.7	5758	6	1525.6	5791	6	1576.2
5725	6	1475.2	5759	6	1527.1	5792	6	1577.8
5726	6	1476.8				5793	6	1579.3
5727	6	1478.3	5760	6	1528.7	5794	6	1580.8
5728	6	1479.8	5761	6	1530.2	5795	6	1582.4
5729	6	1481.3	5762	6	1531.7	5796	6	1583.9
			5763	6	1533.3	5797	6	1585.5
5730	6	1482.8	5764	6	1534.8	5798	6	1587.0
5731	6	1484.3	5765	6	1536.3	5799	6	1588.5
5732	6	1485.9	5766	6	1537.9			
5733	6	1487.4	5767	6	1539.4	5800	6	1590.1

Use check point at 5800 Kc

Frequency: 5900-6000 Kc

Freq.	A	B	Freq.	A	B	Freq.	A	B
5900	6	1746.8	5934	6	1801.5	5968	6	1856.9
5901	6	1748.4	5935	6	1803.1	5969	6	1858.6
5902	6	1750.0	5936	6	1804.7			
5903	6	1751.6	5937	6	1806.3	5970	6	1860.2
5904	6	1753.2	5938	6	1808.0	5971	6	1861.9
5905	6	1754.8	5939	6	1809.6	5972	6	1863.5
5906	6	1756.4				5973	6	1865.2
5907	6	1758.0	5940	6	1811.2	5974	6	1866.8
5908	6	1759.6	5941	6	1812.8	5975	6	1868.5
5909	6	1761.2	5942	6	1814.4	5976	6	1870.1
			5943	6	1816.1	5977	6	1871.8
5910	6	1762.8	5944	6	1817.7	5978	6	1873.5
5911	6	1764.4	5945	6	1819.3	5979	6	1875.1
5912	6	1766.0	5946	6	1820.9			
5913	6	1767.7	5947	6	1822.6	5980	6	1876.8
5914	6	1769.3	5948	6	1824.2	5981	6	1878.4
5915	6	1770.9	5949	6	1825.8	5982	6	1880.1
5916	6	1772.5				5983	6	1881.7
5917	6	1774.1	5950	6	1827.4	5984	6	1883.4
5918	6	1775.7	5951	6	1829.1	5985	6	1885.1
5919	6	1777.3	5952	6	1830.7	5986	6	1886.7
			5953	6	1832.3	5987	6	1888.4
5920	6	1778.9	5954	6	1833.9	5988	6	1890.1
5921	6	1780.5	5955	6	1835.6	5989	6	1891.7
5922	6	1782.1	5956	6	1837.2			
5923	6	1783.7	5957	6	1838.8	5990	6	1893.4
5924	6	1785.3	5958	6	1840.4	5991	6	1895.0
5925	6	1787.0	5959	6	1842.1	5992	6	1896.7
5926	6	1788.6				5993	6	1898.4
5927	6	1790.2	5960	6	1843.7	5994	6	1900.0
5928	6	1791.8	5961	6	1845.3	5995	6	1901.7
5929	6	1793.4	5962	6	1847.0	5996	6	1903.4
			5963	6	1848.6	5997	6	1905.0
5930	6	1795.0	5964	6				

**TABLE 6-10. CALIBRATION OF HIGH FREQUENCY OSCILLATOR
2000K TO 18100K**

Frequency: 6000-6100 Kc						Frequency: 6200-6300 Kc					
Freq.	A	B	Freq.	A	B	Freq.	A	B	Freq.	A	B
6000	7	100.1	6034	7	142.0	6068	7	183.8	6200	7	345.8
6001	7	101.4	6035	7	143.3	6069	7	185.0	6201	7	347.1
6002	7	102.6	6036	7	144.5				6202	7	348.3
6003	7	103.8	6037	7	145.7	6070	7	186.2	6203	7	349.5
6004	7	105.1	6038	7	147.0	6071	7	187.4	6204	7	350.8
6005	7	106.3	6039	7	148.2	6072	7	188.7	6205	7	352.0
6006	7	107.5				6073	7	189.9	6206	7	353.2
6007	7	108.8	6040	7	149.4	6074	7	191.1	6207	7	354.4
6008	7	110.0	6041	7	150.6	6075	7	192.3	6208	7	355.7
6009	7	111.2	6042	7	151.9	6076	7	193.6	6209	7	356.9
			6043	7	153.1	6077	7	194.8			
6010	7	112.5	6044	7	154.3	6078	7	196.0	6210	7	358.1
6011	7	113.7	6045	7	155.6	6079	7	197.2	6211	7	359.4
6012	7	114.9	6046	7	156.8				6212	7	360.6
6013	7	116.2	6047	7	158.0	6080	7	198.5	6213	7	361.8
6014	7	117.4	6048	7	159.2	6081	7	199.7	6214	7	363.1
6015	7	118.6	6049	7	160.5	6082	7	200.9	6215	7	364.3
6016	7	119.9				6083	7	202.1	6216	7	365.5
6017	7	121.1	6050	7	161.7	6084	7	203.3	6217	7	366.8
6018	7	122.3	6051	7	162.9	6085	7	204.6	6218	7	368.0
6019	7	123.6	6052	7	164.1	6086	7	205.8	6219	7	369.2
			6053	7	165.4	6087	7	207.0			
6020	7	124.8	6054	7	166.6	6088	7	208.2	6220	7	370.4
6021	7	126.0	6055	7	167.8	6089	7	209.5	6221	7	371.7
6022	7	127.3	6056	7	169.1				6222	7	372.9
6023	7	128.5	6057	7	170.3	6090	7	210.7	6223	7	374.1
6024	7	129.7	6058	7	171.5	6091	7	211.9	6224	7	375.4
6025	7	131.0	6059	7	172.7	6092	7	213.1	6225	7	376.6
6026	7	132.2				6093	7	214.4	6226	7	377.8
6027	7	133.4	6060	7	174.0	6094	7	215.6	6227	7	379.1
6028	7	134.7	6061	7	175.2	6095	7	216.8	6228	7	380.3
6029	7	135.9	6062	7	176.4	6096	7	218.0	6229	7	381.5
			6063	7	177.6	6097	7	219.3			
6030	7	137.1	6064	7	178.9	6098	7	220.5	6230	7	382.8
6031	7	138.4	6065	7	180.1	6099	7	221.7	6231	7	384.0
6032	7	139.6	6066	7	181.3				6232	7	385.2
6033	7	140.8	6067	7	182.5	6100	7	222.9	6233	7	386.4

Use check point at 6000 Kc

Use check point at 6300 Kc

Frequency: 6100-6200 Kc					
Freq.	A	B	Freq.	A	B
6100	7	222.9	6134	7	264.6
6101	7	224.2	6135	7	265.9
6102	7	225.4	6136	7	267.1
6103	7	226.6	6137	7	268.3
6104	7	227.8	6138	7	269.6
6105	7	229.1	6139	7	270.8
6106	7	230.3			
6107	7	231.5	6140	7	272.0
6108	7	232.7	6141	7	273.2
6109	7	234.0	6142	7	274.5
			6143	7	275.7
6110	7	235.2	6144	7	276.9
6111	7	236.4	6145	7	278.2
6112	7	237.6	6146	7	279.4
6113	7	238.9	6147	7	280.6
6114	7	240.1	6148	7	281.8
6115	7	241.3	6149	7	283.1
6116	7	242.5			
6117	7	243.8	6150	7	284.3
6118	7	245.0	6151	7	285.5
6119	7	246.2	6152	7	286.8
			6153	7	288.0
6120	7	247.4	6154	7	289.2
6121	7	248.7	6155	7	290.5
6122	7	249.9	6156	7	291.7
6123	7	251.1	6157	7	292.9
6124	7	252.4	6158	7	294.2
6125	7	253.6	6159	7	295.4
6126	7	254.8			
6127	7	256.0	6160	7	296.6
6128	7	257.3	6161	7	297.8
6129	7	258.5	6162	7	299.1
			6163	7	300.3
6130	7	259.7	6164	7	301.5
6131	7	261.0	6165	7	302.8
6132	7	262.2	6166	7	304.0
6133	7	263.4	6167	7	305.2

Use check point at 6000 or 6300 Kc, whichever is nearer

Frequency: 6300-6400 Kc					
Freq.	A	B	Freq.	A	B
6300	7	469.6	6334	7	511.7
6301	7	470.8	6335	7	513.0
6302	7	472.0	6336	7	514.2
6303	7	473.3	6337	7	515.4
6304	7	474.5	6338	7	516.7
6305	7	475.8	6339	7	517.9
6306	7	477.0			
6307	7	478.2	6340	7	519.2
6308	7	479.5	6341	7	520.4
6309	7	480.7	6342	7	521.7
			6343	7	522.9
6310	7	482.0	6344	7	524.2
6311	7	483.2	6345	7	525.4
6312	7	484.4	6346	7	526.7
6313	7	485.7	6347	7	527.9
6314	7	486.9	6348	7	529.2
6315	7	488.1	6349	7	530.4
6316	7	489.4			
6317	7	490.6	6350	7	531.7
6318	7	491.9	6351	7	532.9
6319	7	493.1	6352	7	534.2
			6353	7	535.4
6320	7	494.3	6354	7	536.6
6321	7	495.6	6355	7	537.9
6322	7	496.8	6356	7	539.1
6323	7	498.1	6357	7	540.4
6324	7	499.3	6358	7	541.6
6325	7	500.5	6359	7	542.9
6326	7	501.8			
6327	7	503.0	6360	7	544.1
6328	7	504.2	6361	7	545.4
6329	7	505.5	6362	7	546.6
			6363	7	547.9
6330	7	506.7	6364	7	549.1
6331	7	508.0	6365	7	550.3
6332	7	509.2	6366	7	551.6
6333	7	510.5	6367	7	552.8

Use check point at 6300 Kc

**TABLE 6-10. CALIBRATION OF HIGH FREQUENCY OSCILLATOR
200KC TO 1810KC**

Frequency: 6400—6500 Kc

Freq.	A	B	Freq.	A	B	Freq.	A	B
6400	7	593.9	6434	7	636.3	6468	7	678.6
6401	7	595.1	6435	7	637.5	6469	7	679.9
6402	7	596.4	6436	7	638.8			
6403	7	597.6	6437	7	640.0	6470	7	681.1
6404	7	598.9	6438	7	641.3	6471	7	682.4
6405	7	600.1	6439	7	642.5	6472	7	683.6
6406	7	601.4				6473	7	684.9
6407	7	602.6	6440	7	643.8	6474	7	686.1
6408	7	603.9	6441	7	645.0	6475	7	687.4
6409	7	605.1	6442	7	646.3	6476	7	688.6
			6443	7	647.5	6477	7	689.8
6410	7	606.4	6444	7	648.8	6478	7	691.1
6411	7	607.6	6445	7	650.0	6479	7	692.3
6412	7	608.9	6446	7	651.2			
6413	7	610.1	6447	7	652.5	6480	7	693.6
6414	7	611.4	6448	7	653.7	6481	7	694.8
6415	7	612.6	6449	7	655.0	6482	7	696.1
6416	7	613.8				6483	7	697.3
6417	7	615.1	6450	7	656.2	6484	7	698.6
6418	7	616.3	6451	7	657.5	6485	7	699.8
6419	7	617.5	6452	7	658.7	6486	7	701.1
			6453	7	660.0	6487	7	702.3
6420	7	618.8	6454	7	661.2	6488	7	703.6
6421	7	620.1	6455	7	662.5	6489	7	704.8
6422	7	621.3	6456	7	663.7			
6423	7	622.6	6457	7	665.0	6490	7	706.0
6424	7	623.8	6458	7	666.2	6491	7	707.3
6425	7	625.1	6459	7	667.4	6492	7	708.5
6426	7	626.3				6493	7	709.8
6427	7	627.6	6460	7	668.7	6494	7	711.0
6428	7	628.8	6461	7	669.9	6495	7	712.3
6429	7	630.1	6462	7	671.2	6496	7	713.5
			6463	7	672.4	6497	7	714.8
6430	7	631.3	6464	7	673.7	6498	7	716.0
6431	7	632.5	6465	7	674.9	6499	7	717.3
6432	7	633.8	6466	7	676.2			
6433	7	635.0	6467	7	677.4	6500	7	718.5

Use check point at 6300 or 6600 Kc, whichever is nearer

Frequency: 6600—6700 Kc

Freq.	A	B	Freq.	A	B	Freq.	A	B
6600	7	843.0	6634	7	885.1	6668	7	927.1
6601	7	844.2	6635	7	886.3	6669	7	928.4
6602	7	845.4	6636	7	887.5			
6603	7	846.7	6637	7	888.8	6670	7	929.6
6604	7	847.9	6638	7	890.0	6671	7	930.8
6605	7	849.2	6639	7	891.3	6672	7	932.1
6606	7	850.4				6673	7	933.3
6607	7	851.7	6640	7	892.5	6674	7	934.6
6608	7	852.9	6641	7	893.7	6675	7	935.8
6609	7	854.1	6642	7	895.0	6676	7	937.0
			6643	7	896.2	6677	7	938.3
6610	7	855.4	6644	7	897.4	6678	7	939.5
6611	7	856.6	6645	7	898.7	6679	7	940.7
6612	7	857.8	6646	7	899.9			
6613	7	859.1	6647	7	901.2	6680	7	942.0
6614	7	860.3	6648	7	902.4	6681	7	943.2
6615	7	861.6	6649	7	903.6	6682	7	944.4
6616	7	862.8				6683	7	945.7
6617	7	864.0	6650	7	904.9	6684	7	946.9
6618	7	865.3	6651	7	906.1	6685	7	948.2
6619	7	866.5	6652	7	907.3	6686	7	949.4
			6653	7	908.6	6687	7	950.6
6620	7	867.7	6654	7	909.8	6688	7	951.9
6621	7	869.0	6655	7	911.1	6689	7	953.1
6622	7	870.2	6656	7	912.3			
6623	7	871.5	6657	7	913.5	6690	7	954.3
6624	7	872.7	6658	7	914.8	6691	7	955.6
6625	7	873.9	6659	7	916.0	6692	7	956.8
6626	7	875.2				6693	7	958.0
6627	7	876.4	6660	7	917.2	6694	7	959.3
6628	7	877.6	6661	7	918.5	6695	7	960.5
6629	7	878.9	6662	7	919.7	6696	7	961.7
			6663	7	921.0	6697	7	963.0
6630	7	880.1	6664	7	922.2	6698	7	964.2
6631	7	881.4	6665	7	923.4	6699	7	965.4
6632	7	882.6	6666	7	924.7			
6633	7	883.8	6667	7	925.9	6700	7	966.6

Use check point at 6600 Kc

Frequency: 6500—6600 Kc

Freq.	A	B	Freq.	A	B	Freq.	A	B
6500	7	718.5	6534	7	671.0	6568	7	803.2
6501	7	719.8	6535	7	762.2	6569	7	804.4
6502	7	721.0	6536	7	763.5			
6503	7	722.2	6537	7	764.7	6570	7	805.7
6504	7	723.5	6538	7	766.0	6571	7	806.9
6505	7	724.7	6539	7	767.2	6572	7	808.2
6506	7	726.0				6573	7	809.4
6507	7	727.2	6540	7	768.5	6574	7	810.7
6508	7	728.5	6541	7	769.7	6575	7	811.9
6509	7	729.7	6542	7	770.9	6576	7	813.1
			6543	7	772.2	6577	7	814.4
6510	7	731.0	6544	7	773.4	6578	7	815.6
6511	7	732.2	6545	7	774.7	6579	7	816.9
6512	7	733.5	6546	7	775.9			
6513	7	734.7	6547	7	777.1	6580	7	818.1
6514	7	736.0	6548	7	778.4	6581	7	819.4
6515	7	737.2	6549	7	779.6	6582	7	820.6
6516	7	738.5				6583	7	821.9
6517	7	739.7	6550	7	780.9	6584	7	823.1
6518	7	741.0	6551	7	782.1	6585	7	824.3
6519	7	742.2	6552	7	783.3	6586	7	825.6
			6553	7	784.6	6587	7	826.8
6520	7	743.5	6554	7	785.8	6588	7	828.1
6521	7	744.7	6555	7	787.1	6589	7	829.3
6522	7	746.0	6556	7	788.3			
6523	7	747.2	6557	7	789.6	6590	7	830.6
6524	7	748.5	6558	7	790.8	6591	7	831.8
6525	7	749.7	6559	7	792.0	6592	7	833.0
6526	7	751.0				6593	7	834.3
6527	7	752.2	6560	7	793.3	6594	7	835.5
6528	7	753.5	6561	7	794.5	6595	7	836.8
6529	7	754.7	6562	7	795.8	6596	7	838.0
			6563	7	797.0	6597	7	839.3
6530	7	756.0	6564	7	798.2	6598	7	840.5
6531	7	757.2	6565	7	799.5	6599	7	841.8
6532	7	758.5	6566	7	800.7			
6533	7	759.7	6567	7	802.0	6600	7	843.0

Use check point at 6600 Kc

Frequency: 6700—6800 Kc

Freq.	A	B	Freq.	A	B	Freq.	A	B
6700	7	966.6	6734	7	1008.5	6768	7	1050.5
6701	7	967.9	6735	7	1009.8	6769	7	1051.7
6702	7	969.1	6736	7	1011.0			
6703	7	970.3	6737	7	1012.2	6770	7	1052.9
6704	7	971.6	6738	7	1013.5	6771	7	1054.2
6705	7	972.8	6739	7	1014.7	6772	7	1055.4
6706	7	974.0				6773	7	1056.6
6707	7	975.3	6740	7	1015.9	6774	7	1057.9
6708	7	976.5	6741	7	1017.2	6775	7	1059.1
6709	7	977.7	6742	7	1018.4	6776	7	1060.3
			6743	7	1019.6	6777	7	1061.6
6710	7	978.9	6744	7	1020.9	6778	7	1062.8
6711	7	980.2	6745	7	1022.1	6779	7	1064.0
6712	7	981.4	6746	7	1023.3			
6713	7	982.6	6747	7	1024.6	6780	7	1065.3
6714	7	983.9	6748	7	1025.8	6781	7	1066.5
6715	7	985.1	6749	7	1027.0	6782	7	1067.7
6716	7	986.3				6783	7	1068.9
6717	7	987.6	6750	7	1028.3	6784	7	1070.1
6718	7	988.8	6751	7	1029.5	6785	7	1071.4
6719	7	990.0	6752	7	1030.7	6786	7	1072.6
			6753	7	1032.0	6787	7	1073.8
6720	7	991.2	6754	7	1033.2	6788	7	1075.0
6721	7	992.5	6755	7	1034.4	6789	7	1076.3
6722	7	993.7	6756	7	1035.7			
6723	7	994.9	6757	7	1036.9	6790	7	1077.5
6724	7	996.2	6758	7	1038.1	6791	7	1078.7
6725	7	997.4	6759	7	1039.4	6792	7	1079.9
6726	7	998.6				6793	7	1081.1
6727	7	999.9	6760	7	1040.6	6794	7	1082.4
6728	7	1001.1	6761	7	1041.8	6795	7	1083.6
6729	7	1002.3	6762	7	1043.1	6796	7	1084.8
			6763	7	1044.3	6797	7	1086.0
6730	7	1003.6	6764	7	1045.5	6798	7	1087.3
6731	7	1004.8	6765	7	1046.8	6799	7	1088.5
6732	7	1006.0	6766	7	1048.0			
6733	7	1007.3	6767	7	1049.2	6800	7	1089.7

Use check point at 6600 or 6900 Kc, whichever is nearer

**TABLE 6-10. CALIBRATION OF HIGH FREQUENCY OSCILLATOR
2000Kc TO 18100Kc**

Frequency: 6800—6900 Kc

Freq.	A	B	Freq.	A	B	Freq.	A	B
6800	7	1089.7	6834	7	1131.3	6868	7	1172.8
6801	7	1090.9	6835	7	1132.5	6869	7	1174.0
6802	7	1092.1	6836	7	1133.7			
6803	7	1093.4	6837	7	1134.9	6870	7	1175.2
6804	7	1094.6	6838	7	1136.2	6871	7	1176.4
6805	7	1095.8	6839	7	1137.4	6872	7	1177.7
6806	7	1097.0				6873	7	1178.9
6807	7	1098.2	6840	7	1138.6	6874	7	1180.1
6808	7	1099.5	6841	7	1139.8	6875	7	1181.3
6809	7	1100.7	6842	7	1141.1	6876	7	1182.5
			6843	7	1142.3	6877	7	1183.8
6810	7	1101.9	6844	7	1143.5	6878	7	1185.0
6811	7	1103.1	6845	7	1144.7	6879	7	1186.2
6812	7	1104.4	6846	7	1145.9			
6813	7	1105.6	6847	7	1147.2	6880	7	1187.4
6814	7	1106.8	6848	7	1148.4	6881	7	1188.6
6815	7	1108.0	6849	7	1149.6	6882	7	1189.9
6816	7	1109.3				6883	7	1191.1
6817	7	1110.5	6850	7	1150.8	6884	7	1192.3
6818	7	1111.7	6851	7	1152.0	6885	7	1193.5
6819	7	1112.9	6852	7	1153.3	6886	7	1194.7
			6853	7	1154.5	6887	7	1195.9
6820	7	1114.1	6854	7	1155.7	6888	7	1197.2
6821	7	1115.4	6855	7	1156.9	6889	7	1198.4
6822	7	1116.6	6856	7	1158.1			
6823	7	1117.8	6857	7	1159.4	6890	7	1199.6
6824	7	1119.0	6858	7	1160.6	6891	7	1200.8
6825	7	1120.3	6859	7	1161.8	6892	7	1202.0
6826	7	1121.5				6893	7	1203.3
6827	7	1122.7	6860	7	1163.0	6894	7	1204.5
6828	7	1123.9	6861	7	1164.2	6895	7	1205.7
6829	7	1125.2	6862	7	1165.5	6896	7	1206.9
			6863	7	1166.7	6897	7	1208.1
6830	7	1126.4	6864	7	1167.9	6898	7	1209.3
6831	7	1127.6	6865	7	1169.1	6899	7	1210.6
6832	7	1128.8	6866	7	1170.3			
6833	7	1130.0	6867	7	1171.6	6900	7	1211.8

Use check point at 6900 Kc

Frequency: 7000—7100 Kc

Freq.	A	B	Freq.	A	B	Freq.	A	B
7000	7	1333.7	7034	7	1375.2	7068	7	1416.7
7001	7	1334.9	7035	7	1376.4	7069	7	1417.9
7002	7	1336.2	7036	7	1377.6			
7003	7	1337.4	7037	7	1378.8	7070	7	1419.1
7004	7	1338.6	7038	7	1380.0	7071	7	1420.3
7005	7	1339.8	7039	7	1381.2	7072	7	1421.6
7006	7	1341.0				7073	7	1422.8
7007	7	1342.3	7040	7	1382.5	7074	7	1424.0
7008	7	1343.5	7041	7	1383.7	7075	7	1425.2
7009	7	1344.7	7042	7	1384.9	7076	7	1426.5
			7043	7	1386.1	7077	7	1427.7
7010	7	1345.9	7044	7	1387.3	7078	7	1428.9
7011	7	1347.1	7045	7	1388.6	7079	7	1430.1
7012	7	1348.4	7046	7	1389.8			
7013	7	1349.6	7047	7	1391.0	7080	7	1431.4
7014	7	1350.8	7048	7	1392.2	7081	7	1432.6
7015	7	1352.0	7049	7	1393.4	7082	7	1433.8
7016	7	1353.2				7083	7	1435.0
7017	7	1354.5	7050	7	1394.6	7084	7	1436.2
7018	7	1355.7	7051	7	1395.9	7085	7	1437.4
7019	7	1356.9	7052	7	1397.1	7086	7	1438.7
			7053	7	1398.3	7087	7	1439.9
7020	7	1358.1	7054	7	1399.5	7088	7	1441.1
7021	7	1359.3	7055	7	1400.8	7089	7	1442.3
7022	7	1360.6	7056	7	1402.0			
7023	7	1361.8	7057	7	1403.2	7090	7	1443.5
7024	7	1363.0	7058	7	1404.4	7091	7	1444.7
7025	7	1364.2	7059	7	1405.7	7092	7	1446.0
7026	7	1365.4				7093	7	1447.2
7027	7	1366.6	7060	7	1406.9	7094	7	1448.4
7028	7	1367.9	7061	7	1408.1	7095	7	1449.6
7029	7	1369.1	7062	7	1409.3	7096	7	1450.8
			7063	7	1410.6	7097	7	1452.0
7030	7	1370.3	7064	7	1411.8	7098	7	1453.3
7031	7	1371.5	7065	7	1413.0	7099	7	1454.5
7032	7	1372.7	7066	7	1414.2			
7033	7	1373.9	7067	7	1415.4	7100	7	1455.7

Use check point at 6900 or 7200 Kc, whichever is nearer

Frequency: 6900—7000 Kc

Freq.	A	B	Freq.	A	B	Freq.	A	B
6900	7	1211.8	6934	7	1253.2	6968	7	1294.6
6901	7	1213.0	6935	7	1254.4	6969	7	1295.8
6902	7	1214.2	6936	7	1255.6			
6903	7	1215.4	6937	7	1256.8	6970	7	1297.1
6904	7	1216.6	6938	7	1258.0	6971	7	1298.3
6905	7	1217.9	6939	7	1259.3	6972	7	1299.5
6906	7	1219.1				6973	7	1300.7
6907	7	1220.3	6940	7	1260.5	6974	7	1302.0
6908	7	1221.5	6941	7	1261.7	6975	7	1303.2
6909	7	1222.7	6942	7	1262.9	6976	7	1304.4
			6943	7	1264.1	6977	7	1305.6
6910	7	1224.0	6944	7	1265.4	6978	7	1306.8
6911	7	1225.2	6945	7	1266.6	6979	7	1308.1
6912	7	1226.4	6946	7	1267.8			
6913	7	1227.6	6947	7	1269.0	6980	7	1309.3
6914	7	1228.8	6948	7	1270.2	6981	7	1310.5
6915	7	1230.0	6949	7	1271.4	6982	7	1311.7
6916	7	1231.3				6983	7	1313.0
6917	7	1232.5	6950	7	1272.7	6984	7	1314.2
6918	7	1233.7	6951	7	1273.9	6985	7	1315.4
6919	7	1234.9	6952	7	1275.1	6986	7	1316.6
			6953	7	1276.3	6987	7	1317.9
6920	7	1236.1	6954	7	1277.5	6988	7	1319.1
6921	7	1237.3	6955	7	1278.8	6989	7	1320.3
6922	7	1238.6	6956	7	1280.0			
6923	7	1239.8	6957	7	1281.2	6990	7	1321.5
6924	7	1241.0	6958	7	1282.4	6991	7	1322.7
6925	7	1242.2	6959	7	1283.6	6992	7	1324.0
6926	7	1243.4				6993	7	1325.2
6927	7	1244.6	6960	7	1284.8	6994	7	1326.4
6928	7	1245.9	6961	7	1286.1	6995	7	1327.6
6929	7	1247.1	6962	7	1287.3	6996	7	1328.8
			6963	7	1288.5	6997	7	1330.1
6930	7	1248.3	6964	7	1289.7	6998	7	1331.3
6931	7	1249.5	6965	7	1291.0	6999	7	1332.5
6932	7	1250.7	6966	7	1292.2			
6933	7	1252.0	6967	7	1293.4	7000	7	1333.7

Use check point at 6900 Kc

Frequency: 7100—7200 Kc

Freq.	A	B	Freq.	A	B	Freq.	A	B
7100	7	1455.7	7134	7	1497.4	7168	7	1539.3
7101	7	1456.9	7135	7	1498.7	7169	7	1540.5
7102	7	1458.1	7136	7	1499.9			
7103	7	1459.3	7137	7	1501.1	7170	7	1541.7
7104	7	1460.6	7138	7	1502.4	7171	7	1543.0
7105	7	1461.8	7139	7	1503.6	7172	7	1544.2
7106	7	1463.0				7173	7	1545.4
7107	7	1464.2	7140	7	1504.8	7174	7	1546.7
7108	7	1465.4	7141	7	1506.1	7175	7	1547.9
7109	7	1466.6	7142	7	1507.3	7176	7	1549.1
			7143	7	1508.5	7177	7	1550.4
7110	7	1467.9	7144	7	1509.8	7178	7	1551.6
7111	7	1469.1	7145	7	1511.0	7179	7	1552.9
7112	7	1470.3	7146	7	1512.2			
7113	7	1471.6	7147	7	1513.4	7180	7	1554.1
7114	7	1472.8	7148	7	1514.7	7181	7	1555.3
7115	7	1474.0	7149	7	1515.9	7182	7	1556.6
7116	7	1475.3				7183	7	1557.8
7117	7	1476.5	7150	7	1517.1	7184	7	1559.1
7118	7	1477.7	7151	7	1518.4	7185	7	1560.3
7119	7	1479.0	7152	7	1519.6	7186	7	1561.5
			7153	7	1520.8	7187	7	1562.8
7120	7	1480.2	7154	7	1522.1	7188	7	1564.0
7121	7	1481.4	7155	7	1523.3	7189	7	1565.2
7122	7	1482.7	7156	7	1524.5			
7123	7	1483.9	7157	7	1525.7	7190	7	1566.5
7124	7	1485.1	7158	7	1527.0	7191	7	1567.7
7125	7	1486.4	7159	7	1528.2	7192	7	1569.0
7126	7	1487.6				7193	7	1570.2
7127	7	1488.8	7160	7	1529.4	7194	7	1571.4
7128	7	1490.0	7161	7	1530.7	7195	7	1572.7
7129	7	1491.3	7162	7	1531.9	7196	7	1573.9
			7163	7	1533.1	7197	7	1575.1
7130	7	1492.5	7164	7	1534			

**TABLE 6-10. CALIBRATION OF HIGH FREQUENCY OSCILLATOR
2000KC TO 18100KC**

Frequency: 7200-7300 Kc						Frequency: 7400-7500 Kc											
Freq.	A	B	Freq.	A	B	Freq.	A	B	Freq.	A	B	Freq.	A	B			
7200	8	60.0	7234	8	94.7	7268	8	129.5	7400	8	263.3	7434	8	297.8			
7201	8	61.0	7235	8	95.8	7269	8	130.5	7401	8	264.3	7435	8	298.8			
7202	8	62.0	7236	8	96.8				7402	8	265.4	7436	8	299.8			
7203	8	63.1	7237	8	97.8	7270	8	131.5	7403	8	266.4	7437	8	300.9			
7204	8	64.1	7238	8	98.8	7271	8	132.5	7404	8	267.4	7438	8	301.9			
7205	8	65.1	7239	8	99.9	7272	8	133.5	7405	8	268.4	7439	8	302.9			
7206	8	66.1				7273	8	134.5	7406	8	269.4			7470	8	334.5	
7207	8	67.2	7240	8	100.9	7274	8	135.6	7407	8	270.4	7440	8	303.9	7471	8	335.5
7208	8	68.2	7241	8	101.9	7275	8	136.6	7408	8	271.5	7441	8	304.9	7472	8	336.5
7209	8	69.2	7242	8	102.9	7276	8	137.6	7409	8	272.5	7442	8	305.9	7473	8	337.5
			7243	8	103.9	7277	8	138.6				7443	8	307.0	7474	8	338.6
7210	8	70.2	7244	8	105.0	7278	8	139.6	7410	8	273.5	7444	8	308.0	7475	8	339.6
7211	8	71.2	7245	8	106.0	7279	8	140.6	7411	8	274.5	7445	8	309.0	7476	8	340.6
7212	8	72.3	7246	8	107.0				7412	8	275.5	7446	8	310.0	7477	8	341.6
7213	8	73.3	7247	8	108.0	7280	8	141.7	7413	8	276.5	7447	8	311.0	7478	8	342.7
7214	8	74.3	7248	8	109.1	7281	8	142.7	7414	8	277.6	7448	8	312.1	7479	8	343.7
7215	8	75.3	7249	8	110.1	7282	8	143.7	7415	8	278.6	7449	8	313.1	7480	8	344.7
7216	8	76.4				7283	8	144.7	7416	8	279.6			7481	8	345.7	
7217	8	77.4	7250	8	111.1	7284	8	145.7	7417	8	280.6	7450	8	314.1	7482	8	346.8
7218	8	78.4	7251	8	112.1	7285	8	146.7	7418	8	281.6	7451	8	315.1	7483	8	347.8
7219	8	79.4	7252	8	113.1	7286	8	147.8	7419	8	282.6	7452	8	316.1	7484	8	348.8
			7253	8	114.2	7287	8	148.8				7453	8	317.2	7485	8	349.8
7220	8	80.4	7254	8	115.2	7288	8	149.8	7420	8	283.6	7454	8	318.2	7486	8	350.8
7221	8	81.5	7255	8	116.2	7289	8	150.8	7421	8	284.6	7455	8	319.2	7487	8	351.9
7222	8	82.5	7256	8	117.2				7422	8	285.7	7456	8	320.2	7488	8	352.9
7223	8	83.5	7257	8	118.3	7290	8	151.8	7423	8	286.7	7457	8	321.2	7489	8	353.9
7224	8	84.5	7258	8	119.3	7291	8	152.8	7424	8	287.7	7458	8	322.2	7490	8	354.9
7225	8	85.6	7259	8	120.3	7292	8	153.8	7425	8	288.7	7459	8	323.3	7491	8	356.0
7226	8	86.6				7293	8	154.9	7426	8	289.7			7492	8	357.0	
7227	8	87.6	7260	8	121.3	7294	8	155.9	7427	8	290.7	7460	8	324.3	7493	8	358.0
7228	8	88.6	7261	8	122.3	7295	8	156.9	7428	8	291.7	7461	8	325.3	7494	8	359.0
7229	8	89.6	7262	8	123.4	7296	8	157.9	7429	8	292.8	7462	8	326.3	7495	8	360.0
			7263	8	124.4	7297	8	158.9				7463	8	327.3	7496	8	361.1
7230	8	90.7	7264	8	125.4	7298	8	159.9	7430	8	293.8	7464	8	328.4	7497	8	362.1
7231	8	91.7	7265	8	126.4	7299	8	160.9	7431	8	294.8	7465	8	329.4	7498	8	363.1
7232	8	92.7	7266	8	127.4				7432	8	295.8	7466	8	330.4	7499	8	364.1
7233	8	93.7	7267	8	128.4	7300	8	161.9	7433	8	296.8	7467	8	331.4	7500	8	365.2

Use check point at 7200 Kc

Use check point at 7500 Kc

Frequency: 7300-7400 Kc						Frequency: 7500-7600 Kc											
Freq.	A	B	Freq.	A	B	Freq.	A	B	Freq.	A	B	Freq.	A	B			
7300	8	161.9	7334	8	196.4	7368	8	230.8	7500	8	365.2	7534	8	399.7			
7301	8	163.0	7335	8	197.4	7369	8	231.8	7501	8	366.2	7535	8	400.7			
7302	8	164.0	7336	8	198.4				7502	8	367.2	7536	8	401.8			
7303	8	165.0	7337	8	199.4	7370	8	232.8	7503	8	368.2	7537	8	402.8			
7304	8	166.0	7338	8	200.4	7371	8	233.9	7504	8	369.2	7538	8	403.8			
7305	8	167.0	7339	8	201.4	7372	8	234.9	7505	8	370.2	7539	8	404.8			
7306	8	168.0				7373	8	235.9	7506	8	371.3			7573	8	439.8	
7307	8	169.0	7340	8	202.5	7374	8	236.9	7507	8	372.3	7540	8	405.9	7574	8	440.8
7308	8	170.0	7341	8	203.5	7375	8	237.9	7508	8	373.3	7541	8	406.9	7575	8	441.8
7309	8	171.0	7342	8	204.5	7376	8	238.9	7509	8	374.3	7542	8	407.9	7576	8	442.8
			7343	8	205.5	7377	8	239.9				7543	8	408.9	7577	8	443.9
7310	8	172.1	7344	8	206.5	7378	8	240.9	7510	8	375.3	7544	8	410.0	7578	8	444.9
7311	8	173.1	7345	8	207.5	7379	8	241.9	7511	8	376.3	7545	8	411.0	7579	8	445.9
7312	8	174.1	7346	8	208.5				7512	8	377.3	7546	8	412.0			
7313	8	175.1	7347	8	209.6	7380	8	243.0	7513	8	378.4	7547	8	413.1	7580	8	447.0
7314	8	176.1	7348	8	210.6	7381	8	244.0	7514	8	379.4	7548	8	414.1	7581	8	448.0
7315	8	177.1	7349	8	211.6	7382	8	245.0	7515	8	380.4	7549	8	415.1	7582	8	449.0
7316	8	178.1				7383	8	246.0	7516	8	381.4			7583	8	450.0	
7317	8	179.1	7350	8	212.6	7384	8	247.0	7517	8	382.4	7550	8	416.1	7584	8	451.1
7318	8	180.2	7351	8	213.6	7385	8	248.1	7518	8	383.4	7551	8	417.2	7585	8	452.1
7319	8	181.2	7352	8	214.6	7386	8	249.1	7519	8	384.5	7552	8	418.2	7586	8	453.1
			7353	8	215.6	7387	8	250.1				7553	8	419.2	7587	8	454.2
7320	8	182.2	7354	8	216.6	7388	8	251.1	7520	8	385.5	7554	8	420.2	7588	8	455.2
7321	8	183.2	7355	8	217.7	7389	8	252.1	7521	8	386.5	7555	8	421.3	7589	8	456.2
7322	8	184.2	7356	8	218.7				7522	8	387.5	7556	8	422.3			
7323	8	185.2	7357	8	219.7	7390	8	253.1	7523	8	388.5	7557	8	423.3	7590	8	457.2
7324	8	186.2	7358	8	220.7	7391	8	254.2	7524	8	389.5	7558	8	424.3	7591	8	458.3
7325	8	187.3	7359	8	221.7	7392	8	255.2	7525	8	390.5	7559	8	425.4	7592	8	459.3
7326	8	188.3				7393	8	256.2	7526	8	391.6			7593	8	460.3	
7327	8	189.3	7360	8	222.7	7394	8	257.2	7527	8	392.6	7560	8	426.4	7594	8	461.3
7328	8	190.3	7361	8	223.7	7395	8	258.2	7528	8	393.6	7561	8	427.4	7595	8	462.3
7329	8	191.3	7362	8	224.7	7396	8	259.2	7529	8	394.6	7562	8	428.4	7596	8	463.4
			7363	8	225.8	7397	8	260.3				7563	8	429.5	7597	8	464.4
7330	8	192.3	7364	8	226.8	7398	8	261.3	7530	8	395.6	7564	8	430.5	7598	8	465.4
7331	8	193.3	7365	8	227.8	7399	8	262.3	7531	8	396.6</						

**TABLE 6-10. CALIBRATION OF HIGH FREQUENCY OSCILLATOR
2000KC TO 18100KC**

Frequency: 7600-7700 Kc

Freq.	A	B	Freq.	A	B	Freq.	A	B
7600	8	467.4	7634	8	502.3	7668	8	537.4
7601	8	468.5	7635	8	503.4	7669	8	538.4
7602	8	469.5	7636	8	504.4			
7603	8	470.5	7637	8	505.4	7670	8	539.5
7604	8	471.5	7638	8	506.5	7671	8	540.5
7605	8	472.5	7639	8	507.5	7672	8	541.5
7606	8	473.5				7673	8	542.5
7607	8	474.6	7640	8	508.6	7674	8	543.6
7608	8	475.6	7641	8	509.6	7675	8	544.6
7609	8	476.6	7642	8	510.6	7676	8	545.6
			7643	8	511.7	7677	8	546.6
7610	8	477.6	7644	8	512.7	7678	8	547.7
7611	8	478.6	7645	8	513.7	7679	8	548.7
7612	8	479.7	7646	8	514.8			
7613	8	480.7	7647	8	515.8	7680	8	549.7
7614	8	481.7	7648	8	516.8	7681	8	550.7
7615	8	482.7	7649	8	517.9	7682	8	551.8
7616	8	483.7				7683	8	552.8
7617	8	484.8	7650	8	518.9	7684	8	553.8
7618	8	485.8	7651	8	519.9	7685	8	554.9
7619	8	486.8	7652	8	521.0	7686	8	555.9
			7653	8	522.0	7687	8	556.9
7620	8	487.8	7654	8	523.0	7688	8	557.9
7621	8	488.9	7655	8	524.1	7689	8	559.0
7622	8	489.9	7656	8	525.1			
7623	8	490.9	7657	8	526.1	7690	8	560.0
7624	8	492.0	7658	8	527.1	7691	8	561.0
7625	8	493.0	7659	8	528.2	7692	8	562.1
7626	8	494.0				7693	8	563.1
7627	8	495.1	7660	8	529.2	7694	8	564.1
7628	8	496.1	7661	8	530.2	7695	8	565.2
7629	8	497.2	7662	8	531.2	7696	8	566.2
			7663	8	532.3	7697	8	567.2
7630	8	498.2	7664	8	533.3	7698	8	568.2
7631	8	499.2	7665	8	534.3	7699	8	569.3
7632	8	500.3	7666	8	535.3			
7633	8	501.3	7667	8	536.4	7700	8	570.3

Use check point at 7500 or 7800 Kc, whichever is nearer

Frequency: 7800-7900 Kc

Freq.	A	B	Freq.	A	B	Freq.	A	B
7800	8	673.4	7834	8	708.4	7868	8	743.4
7801	8	674.4	7835	8	709.4	7869	8	744.5
7802	8	675.5	7836	8	710.4			
7803	8	676.5	7837	8	711.5	7870	8	745.5
7804	8	677.5	7838	8	712.5	7871	8	746.5
7805	8	678.6	7839	8	713.5	7872	8	747.5
7806	8	679.6				7873	8	748.6
7807	8	680.6	7840	8	714.6	7874	8	749.6
7808	8	681.6	7841	8	715.6	7875	8	750.6
7809	8	682.7	7842	8	716.6	7876	8	751.6
			7843	8	717.7	7877	8	752.7
7810	8	683.7	7844	8	718.7	7878	8	753.7
7811	8	684.7	7845	8	719.8	7879	8	754.7
7812	8	685.7	7846	8	720.8			
7813	8	686.8	7847	8	721.8	7880	8	755.7
7814	8	687.8	7848	8	722.9	7881	8	756.8
7815	8	688.8	7849	8	723.9	7882	8	757.8
7816	8	689.9				7883	8	758.8
7817	8	690.9	7850	8	724.9	7884	8	759.8
7818	8	691.9	7851	8	726.0	7885	8	760.8
7819	8	692.9	7852	8	727.0	7886	8	761.9
			7853	8	728.0	7887	8	762.9
7820	8	694.0	7854	8	729.1	7888	8	763.9
7821	8	695.0	7855	8	730.1	7889	8	764.9
7822	8	696.0	7856	8	731.1			
7823	8	697.0	7857	8	732.2	7890	8	766.0
7824	8	698.1	7858	8	733.2	7891	8	767.0
7825	8	699.1	7859	8	734.2	7892	8	768.0
7826	8	700.1				7893	8	769.1
7827	8	701.2	7860	8	735.3	7894	8	770.1
7828	8	702.2	7861	8	736.3	7895	8	771.1
7829	8	703.2	7862	8	737.3	7896	8	772.1
			7863	8	738.3	7897	8	773.2
7830	8	704.2	7864	8	739.4	7898	8	774.2
7831	8	705.3	7865	8	740.4	7899	8	775.2
7832	8	706.3	7866	8	741.4			
7833	8	707.3	7867	8	742.4	7900	8	776.3

Use check point at 7800 Kc

Frequency: 7700-7800 Kc

Freq.	A	B	Freq.	A	B	Freq.	A	B
7700	8	570.3	7734	8	605.4	7768	8	640.4
7701	8	571.3	7735	8	606.4	7769	8	641.5
7702	8	572.4	7736	8	607.4			
7703	8	573.4	7737	8	608.5	7770	8	642.5
7704	8	574.4	7738	8	609.5	7771	8	643.5
7705	8	575.4	7739	8	610.5	7772	8	644.6
7706	8	576.5				7773	8	645.6
7707	8	577.5	7740	8	611.6	7774	8	646.6
7708	8	578.5	7741	8	612.6	7775	8	647.7
7709	8	579.6	7742	8	613.6	7776	8	648.7
			7743	8	614.7	7777	8	649.7
7710	8	580.6	7744	8	615.7	7778	8	650.7
7711	8	581.6	7745	8	616.7	7779	8	651.8
7712	8	582.6	7746	8	617.8			
7713	8	583.7	7747	8	618.8	7780	8	652.8
7714	8	584.7	7748	8	619.8	7781	8	653.8
7715	8	585.7	7749	8	620.9	7782	8	654.9
7716	8	586.8				7783	8	655.9
7717	8	587.8	7750	8	621.9	7784	8	656.9
7718	8	588.8	7751	8	622.9	7785	8	658.0
7719	8	589.9	7752	8	623.9	7786	8	659.0
			7753	8	625.0	7787	8	660.0
7720	8	590.9	7754	8	626.0	7788	8	661.1
7721	8	591.9	7755	8	627.0	7789	8	662.1
7722	8	593.0	7756	8	628.1			
7723	8	594.0	7757	8	629.1	7790	8	663.1
7724	8	595.0	7758	8	630.1	7791	8	664.1
7725	8	596.1	7759	8	631.2	7792	8	665.2
7726	8	597.1				7793	8	666.2
7727	8	598.1	7760	8	632.2	7794	8	667.2
7728	8	599.2	7761	8	633.2	7795	8	668.3
7729	8	600.2	7762	8	634.3	7796	8	669.3
			7763	8	635.3	7797	8	670.3
7730	8	601.2	7764	8	636.3	7798	8	671.4
7731	8	602.3	7765	8	637.3	7799	8	672.4
7732	8	603.3	7766	8	638.4			
7733	8	604.3	7767	8	639.4	7800	8	673.4

Use check point at 7800 Kc

Frequency: 7900-8000 Kc

Freq.	A	B	Freq.	A	B	Freq.	A	B
7900	8	776.3	7934	8	811.4	7968	8	846.4
7901	8	777.3	7935	8	812.4	7969	8	847.5
7902	8	778.3	7936	8	813.4			
7903	8	779.4	7937	8	814.5	7970	8	848.5
7904	8	780.4	7938	8	815.5	7971	8	849.5
7905	8	781.4	7939	8	816.6	7972	8	850.5
7906	8	782.4				7973	8	851.6
7907	8	783.5	7940	8	817.6	7974	8	852.6
7908	8	784.5	7941	8	818.6	7975	8	853.6
7909	8	785.5	7942	8	819.7	7976	8	854.7
			7943	8	820.7	7977	8	855.7
7910	8	786.6	7944	8	821.7	7978	8	856.7
7911	8	787.6	7945	8	822.8	7979	8	857.7
7912	8	788.6	7946	8	823.8			
7913	8	789.7	7947	8	824.9	7980	8	858.8
7914	8	790.7	7948	8	825.9	7981	8	859.8
7915	8	791.7	7949	8	826.9	7982	8	860.8
7916	8	792.7				7983	8	861.8
7917	8	793.8	7950	8	828.0	7984	8	862.8
7918	8	794.8	7951	8	829.0	7985	8	863.8
7919	8	795.8	7952	8	830.0	7986	8	864.8
			7953	8	831.0	7987	8	865.8
7920	8	796.9	7954	8	832.1	7988	8	866.9
7921	8	797.9	7955	8	833.1	7989	8	867.9
7922	8	798.9	7956	8	834.1			
7923	8	800.0	7957	8	835.1	7990	8	868.9
7924	8	801.0	7958	8	836.2	7991	8	869.9
7925	8	802.0	7959	8	837.2	7992	8	870.9
7926	8	803.1				7993	8	871.9
7927	8	804.1	7960	8	838.2	7994	8	872.9
7928	8	805.2	7961	8	839.3	7995	8	874.0
7929	8	806.2	7962	8	840.3	7996	8	875.0
			7963	8	841.3	7997	8	876.0
7930	8	807.2	7964	8	842.3	7998	8	877.0
7931	8	808.3	7965	8	843.4	7999	8	878.0
7932	8	809.3	7966	8	844.4			
7933	8	810.3	7967	8	845.4	8000	8	879.0

Use check point at 7800 or 8100 Kc, whichever is nearer

**TABLE 6-10. CALIBRATION OF HIGH FREQUENCY OSCILLATOR
2000Kc TO 18100Kc**

Frequency: 8000—8100 Kc

Freq.	A	B	Freq.	A	B	Freq.	A	B
8000	8	879.0	8034	8	913.8	8068	8	948.6
8001	8	880.0	8035	8	914.9	8069	8	949.6
8002	8	881.0	8036	8	915.9			
8003	8	882.1	8037	8	916.9	8070	8	950.7
8004	8	883.1	8038	8	918.0	8071	8	951.7
8005	8	884.1	8039	8	919.0	8072	8	952.7
8006	8	885.1				8073	8	953.7
8007	8	886.1	8040	8	920.0	8074	8	954.8
8008	8	887.1	8041	8	921.0	8075	8	955.8
8009	8	888.1	8042	8	922.1	8076	8	956.8
			8043	8	923.1	8077	8	957.8
8010	8	889.1	8044	8	924.1	8078	8	958.8
8011	8	890.2	8045	8	925.1	8079	8	959.9
8012	8	891.2	8046	8	926.1			
8013	8	892.2	8047	8	927.2	8080	8	960.9
8014	8	893.3	8048	8	928.2	8081	8	961.9
8015	8	894.3	8049	8	929.2	8082	8	962.9
8016	8	895.3				8083	8	964.0
8017	8	896.3	8050	8	930.2	8084	8	965.0
8018	8	897.4	8051	8	931.3	8085	8	966.0
8019	8	898.4	8052	8	932.3	8086	8	967.0
			8053	8	933.3	8087	8	968.1
8020	8	899.4	8054	8	934.3	8088	8	969.1
8021	8	900.5	8055	8	935.3	8089	8	970.1
8022	8	901.5	8056	8	936.4			
8023	8	902.5	8057	8	937.4	8090	8	971.1
8024	8	903.6	8058	8	938.4	8091	8	972.2
8025	8	904.6	8059	8	939.4	8092	8	973.2
8026	8	905.6				8093	8	974.2
8027	8	906.6	8060	8	940.4	8094	8	975.2
8028	8	907.7	8061	8	941.5	8095	8	976.2
8029	8	908.7	8062	8	942.5	8096	8	977.3
			8063	8	943.5	8097	8	978.3
8030	8	909.7	8064	8	944.5	8098	8	979.3
8031	8	910.8	8065	8	945.6	8099	8	980.3
8032	8	911.8	8066	8	946.6			
8033	8	912.8	8067	8	947.6	8100	8	981.4

Use check point at 8100 Kc

Frequency: 8200—8300 Kc

Freq.	A	B	Freq.	A	B	Freq.	A	B
8200	8	1083.1	8234	8	1117.6	8268	8	1152.1
8201	8	1084.1	8235	8	1118.6	8269	8	1153.1
8202	8	1085.2	8236	8	1119.7			
8203	8	1086.2	8237	8	1120.7	8270	8	1154.1
8204	8	1087.2	8238	8	1121.7	8271	8	1155.1
8205	8	1088.2	8239	8	1122.7	8272	8	1156.1
8206	8	1089.2				8273	8	1157.1
8207	8	1090.2	8240	8	1123.7	8274	8	1158.1
8208	8	1091.3	8241	8	1124.7	8275	8	1159.2
8209	8	1092.3	8242	8	1125.7	8276	8	1160.2
			8243	8	1126.7	8277	8	1161.2
8210	8	1093.3	8244	8	1127.8	8278	8	1162.2
8211	8	1094.3	8245	8	1128.8	8279	8	1163.2
8212	8	1095.3	8246	8	1129.8			
8213	8	1096.3	8247	8	1130.8	8280	8	1164.2
8214	8	1097.3	8248	8	1131.8	8281	8	1165.2
8215	8	1098.4	8249	8	1132.8	8282	8	1166.2
8216	8	1099.4				8283	8	1167.2
8217	8	1100.4	8250	8	1133.8	8284	8	1168.2
8218	8	1101.4	8251	8	1134.9	8285	8	1169.3
8219	8	1102.4	8252	8	1135.9	8286	8	1170.3
			8253	8	1136.9	8287	8	1171.3
8220	8	1103.4	8254	8	1137.9	8288	8	1172.3
8221	8	1104.5	8255	8	1138.9	8289	8	1173.3
8222	8	1105.5	8256	8	1139.9			
8223	8	1106.5	8257	8	1140.9	8290	8	1174.3
8224	8	1107.5	8258	8	1141.9	8291	8	1175.3
8225	8	1108.5	8259	8	1143.0	8292	8	1176.3
8226	8	1109.5				8293	8	1177.3
8227	8	1110.5	8260	8	1144.0	8294	8	1178.3
8228	8	1111.5	8261	8	1145.0	8295	8	1179.3
8229	8	1112.6	8262	8	1146.0	8296	8	1180.3
			8263	8	1147.0	8297	8	1181.3
8230	8	1113.6	8264	8	1148.0	8298	8	1182.4
8231	8	1114.6	8265	8	1149.0	8299	8	1183.4
8232	8	1115.6	8266	8	1150.0			
8233	8	1116.6	8267	8	1151.1	8300	8	1184.4

Use check point at 8100 or 8400 Kc, whichever is nearer

Frequency: 8100—8200 Kc

Freq.	A	B	Freq.	A	B	Freq.	A	B
8100	8	981.4	8134	8	1016.0	8168	8	1050.6
8101	8	982.4	8135	8	1017.0	8169	8	1051.6
8102	8	983.4	8136	8	1018.1			
8103	8	984.4	8137	8	1019.1	8170	8	1052.6
8104	8	985.4	8138	8	1020.1	8171	8	1053.7
8105	8	986.5	8139	8	1021.1	8172	8	1054.7
8106	8	987.5				8173	8	1055.7
8107	8	988.5	8140	8	1022.1	8174	8	1056.7
8108	8	989.5	8141	8	1023.2	8175	8	1057.7
8109	8	990.5	8142	8	1024.2	8176	8	1058.7
			8143	8	1025.2	8177	8	1059.8
8110	8	991.6	8144	8	1026.2	8178	8	1060.8
8111	8	992.6	8145	8	1027.2	8179	8	1061.8
8112	8	993.6	8146	8	1028.2			
8113	8	994.6	8147	8	1029.3	8180	8	1062.8
8114	8	995.6	8148	8	1030.3	8181	8	1063.8
8115	8	996.7	8149	8	1031.3	8182	8	1064.8
8116	8	997.7				8183	8	1065.9
8117	8	998.7	8150	8	1032.3	8184	8	1066.9
8118	8	999.7	8151	8	1033.3	8185	8	1067.9
8119	8	1000.7	8152	8	1034.3	8186	8	1068.9
			8153	8	1035.4	8187	8	1069.9
8120	8	1001.8	8154	8	1036.4	8188	8	1070.9
8121	8	1002.8	8155	8	1037.4	8189	8	1072.0
8122	8	1003.8	8156	8	1038.4			
8123	8	1004.8	8157	8	1039.4	8190	8	1073.0
8124	8	1005.8	8158	8	1040.4	8191	8	1074.0
8125	8	1006.9	8159	8	1041.5	8192	8	1075.0
8126	8	1007.9				8193	8	1076.0
8127	8	1008.9	8160	8	1042.5	8194	8	1077.0
8128	8	1009.9	8161	8	1043.5	8195	8	1078.1
8129	8	1010.9	8162	8	1044.5	8196	8	1079.1
			8163	8	1045.5	8197	8	1080.1
8130	8	1012.0	8164	8	1046.5	8198	8	1081.1
8131	8	1013.0	8165	8	1047.6	8199	8	1082.1
8132	8	1014.0	8166	8	1048.6			
8133	8	1015.0	8167	8	1049.6	8200	8	1083.1

Use check point at 8100 Kc

Frequency: 8300—8400 Kc

Freq.	A	B	Freq.	A	B	Freq.	A	B
8300	8	1184.4	8334	8	1218.8	8368	8	1253.1
8301	8	1185.4	8335	8	1219.8	8369	8	1254.1
8302	8	1186.4	8336	8	1220.8			
8303	8	1187.4	8337	8	1221.9	8370	8	1255.1
8304	8	1188.4	8338	8	1222.9	8371	8	1256.1
8305	8	1189.4	8339	8	1223.9	8372	8	1257.1
8306	8	1190.4				8373	8	1258.1
8307	8	1191.4	8340	8	1224.9	8374	8	1259.1
8308	8	1192.4	8341	8	1225.9	8375	8	1260.1
8309	8	1193.4	8342	8	1226.9	8376	8	1261.1
			8343	8	1227.9	8377	8	1262.1
8310	8	1194.4	8344	8	1228.9	8378	8	1263.2
8311	8	1195.5	8345	8	1229.9	8379	8	1264.2
8312	8	1196.5	8346	8	1230.9			
8313	8	1197.5	8347	8	1231.9	8380	8	1265.2
8314	8	1198.5	8348	8	1233.0	8381	8	1266.2
8315	8	1199.5	8349	8	1234.0	8382	8	1267.2
8316	8	1200.5				8383	8	1268.2
8317	8	1201.5	8350	8	1235.0	8384	8	1269.2
8318	8	1202.6	8351	8	1236.0	8385	8	1270.2
8319	8	1203.6	8352	8	1237.0	8386	8	1271.2
			8353	8	1238.0	8387	8	1272.2
8320	8	1204.6	8354	8	1239.0	8388	8	1273.2
8321	8	1205.6	8355	8	1240.0	8389	8	1274.2
8322	8	1206.6	8356	8	1241.0			
8323	8	1207.6	8357	8	1242.0	8390	8	1275.2
8324	8	1208.7	8358	8	1243.0	8391	8	1276.2
8325	8	1209.7	8359	8	1244.0	8392	8	1277.2
8326	8	1210.7				8393	8	1278.3
8327	8	1211.7	8360	8	1245.0	8394	8	1279.3
8328	8	1212.7	8361	8	1246.0	8395	8	1280.3
8329	8	1213.7	8362	8	1247.0	8396	8	1281.3
			8363	8	1248.1	8397	8	1282.3
8330	8	1214.7	8364	8	1249.1	8398	8	1283.3
8331	8	1215.8	8365	8	1250.1	8399	8	1284.3

**TABLE 6-10. CALIBRATION OF HIGH FREQUENCY OSCILLATOR
200KC TO 1810KC**

Frequency: 8400—8500 Kc

Freq.	A	B	Freq.	A	B	Freq.	A	B
8400	8	1285.3	8434	8	1319.7	8468	8	1354.0
8401	8	1286.3	8435	8	1320.7	8469	8	1355.1
8402	8	1287.3	8436	8	1321.7			
8403	8	1288.3	8437	8	1322.7	8470	8	1356.1
8404	8	1289.3	8438	8	1323.7	8471	8	1357.1
8405	8	1290.4	8439	8	1324.8	8472	8	1358.1
8406	8	1291.4				8473	8	1359.1
8407	8	1292.4	8440	8	1325.8	8474	8	1360.1
8408	8	1293.4	8441	8	1326.8	8475	8	1361.1
8409	8	1294.4	8442	8	1327.8	8476	8	1362.1
			8443	8	1328.8	8477	8	1363.1
8410	8	1295.4	8444	8	1329.8	8478	8	1364.2
8411	8	1296.4	8445	8	1330.8	8479	8	1365.2
8412	8	1297.4	8446	8	1331.8			
8413	8	1298.5	8447	8	1332.8	8480	8	1366.2
8414	8	1299.5	8448	8	1333.8	8481	8	1367.2
8415	8	1300.5	8449	8	1334.9	8482	8	1368.2
8416	8	1301.5				8483	8	1369.2
8417	8	1302.5	8450	8	1335.9	8484	8	1370.2
8418	8	1303.5	8451	8	1336.9	8485	8	1371.2
8419	8	1304.5	8452	8	1337.9	8486	8	1372.2
			8453	8	1338.9	8487	8	1373.2
8420	8	1305.5	8454	8	1339.9	8488	8	1374.3
8421	8	1306.6	8455	8	1340.9	8489	8	1375.3
8422	8	1307.6	8456	8	1341.9			
8423	8	1308.6	8457	8	1342.9	8490	8	1376.3
8424	8	1309.6	8458	8	1343.9	8491	8	1377.3
8425	8	1310.6	8459	8	1345.0	8492	8	1378.3
8426	8	1311.6				8493	8	1379.3
8427	8	1312.6	8460	8	1346.0	8494	8	1380.3
8428	8	1313.6	8461	8	1347.0	8495	8	1381.3
8429	8	1314.6	8462	8	1348.0	8496	8	1382.3
			8463	8	1349.0	8497	8	1383.4
8430	8	1315.7	8464	8	1350.0	8498	8	1384.4
8431	8	1316.7	8465	8	1351.0	8499	8	1385.4
8432	8	1317.7	8466	8	1352.0			
8433	8	1318.7	8467	8	1353.0	8500	8	1386.4

Use check point at 8400 Kc

Frequency: 8600—8700 Kc

Freq.	A	B	Freq.	A	B	Freq.	A	B
8600	8	1487.9	8634	8	1522.5	8668	8	1557.2
8601	8	1488.9	8635	8	1523.6	8669	8	1558.3
8602	8	1489.9	8636	8	1524.6			
8603	8	1490.9	8637	8	1525.6	8670	8	1559.3
8604	8	1491.9	8638	8	1526.6	8671	8	1560.3
8605	8	1493.0	8639	8	1527.7	8672	8	1561.3
8606	8	1494.0				8673	8	1562.4
8607	8	1495.0	8640	8	1528.7	8674	8	1563.4
8608	8	1496.0	8641	8	1529.7	8675	8	1564.4
8609	8	1497.0	8642	8	1530.7	8676	8	1565.4
			8643	8	1531.7	8677	8	1566.5
8610	8	1498.0	8644	8	1532.8	8678	8	1567.5
8611	8	1499.0	8645	8	1533.8	8679	8	1568.5
8612	8	1500.1	8646	8	1534.8			
8613	8	1501.1	8647	8	1535.8	8680	8	1569.5
8614	8	1502.1	8648	8	1536.8	8681	8	1570.6
8615	8	1503.1	8649	8	1537.9	8682	8	1571.6
8616	8	1504.2				8683	8	1572.6
8617	8	1505.2	8650	8	1538.9	8684	8	1573.7
8618	8	1506.2	8651	8	1539.9	8685	8	1574.7
8619	8	1507.2	8652	8	1540.9	8686	8	1575.7
			8653	8	1541.9	8687	8	1576.7
8620	8	1508.2	8654	8	1543.0	8688	8	1577.8
8621	8	1509.3	8655	8	1544.0	8689	8	1578.8
8622	8	1510.3	8656	8	1545.0			
8623	8	1511.3	8657	8	1546.0	8690	8	1579.8
8624	8	1512.3	8658	8	1547.0	8691	8	1580.8
8625	8	1513.4	8659	8	1548.1	8692	8	1581.9
8626	8	1514.4				8693	8	1582.9
8627	8	1515.4	8660	8	1549.1	8694	8	1583.9
8628	8	1516.4	8661	8	1550.1	8695	8	1584.9
8629	8	1517.4	8662	8	1551.1	8696	8	1586.0
			8663	8	1552.1	8697	8	1587.0
8630	8	1518.5	8664	8	1553.2	8698	8	1588.0
8631	8	1519.5	8665	8	1554.2	8699	8	1589.1
8632	8	1520.5	8666	8	1555.2			
8633	8	1521.5	8667	8	1556.2	8700	8	1590.1

Use check point at 8700 Kc

Frequency: 8500—8600 Kc

Freq.	A	B	Freq.	A	B	Freq.	A	B
8500	8	1386.4	8534	8	1420.8	8568	8	1455.4
8501	8	1387.4	8535	8	1421.8	8569	8	1456.4
8502	8	1388.4	8536	8	1422.8			
8503	8	1389.4	8537	8	1423.9	8570	8	1457.4
8504	8	1390.4	8538	8	1424.9	8571	8	1458.5
8505	8	1391.4	8539	8	1425.9	8572	8	1459.5
8506	8	1392.5				8573	8	1460.5
8507	8	1393.5	8540	8	1426.9	8574	8	1461.5
8508	8	1394.5	8541	8	1427.9	8575	8	1462.5
8509	8	1395.5	8542	8	1428.9	8576	8	1463.6
			8543	8	1430.0	8577	8	1464.6
8510	8	1396.5	8544	8	1431.0	8578	8	1465.6
8511	8	1397.5	8545	8	1432.0	8579	8	1466.6
8512	8	1398.5	8546	8	1433.0			
8513	8	1399.5	8547	8	1434.0	8580	8	1467.6
8514	8	1400.5	8548	8	1435.0	8581	8	1468.7
8515	8	1401.5	8549	8	1436.0	8582	8	1469.7
8516	8	1402.6				8583	8	1470.7
8517	8	1403.6	8550	8	1437.1	8584	8	1471.7
8518	8	1404.6	8551	8	1438.1	8585	8	1472.7
8519	8	1405.6	8552	8	1439.1	8586	8	1473.7
			8553	8	1440.1	8587	8	1474.7
8520	8	1406.6	8554	8	1441.1	8588	8	1475.7
8521	8	1407.6	8555	8	1442.2	8589	8	1476.8
8522	8	1408.6	8556	8	1443.2			
8523	8	1409.6	8557	8	1444.2	8590	8	1477.8
8524	8	1410.7	8558	8	1445.2	8591	8	1478.8
8525	8	1411.7	8559	8	1446.2	8592	8	1479.8
8526	8	1412.7				8593	8	1480.8
8527	8	1413.7	8560	8	1447.3	8594	8	1481.8
8528	8	1414.7	8561	8	1448.3	8595	8	1482.8
8529	8	1415.7	8562	8	1449.3	8596	8	1483.8
			8563	8	1450.3	8597	8	1484.9
8530	8	1416.8	8564	8	1451.3	8598	8	1485.9
8531	8	1417.8	8565	8	1452.4	8599	8	1486.9
8532	8	1418.8	8566	8	1453.4			
8533	8	1419.8	8567	8	1454.4	8600	8	1487.9

Use check point at 8400 or 8700 Kc, whichever is nearer

Frequency: 8700—8800 Kc

Freq.	A	B	Freq.	A	B	Freq.	A	B
8700	8	1590.1	8734	8	1625.2	8768	8	1660.6
8701	8	1591.1	8735	8	1626.3	8769	8	1661.7
8702	8	1592.1	8736	8	1627.3			
8703	8	1593.2	8737	8	1628.3	8770	8	1662.7
8704	8	1594.2	8738	8	1629.4	8771	8	1663.7
8705	8	1595.2	8739	8	1630.4	8772	8	1664.8
8706	8	1596.3				8773	8	1665.8
8707	8	1597.3	8740	8	1631.5	8774	8	1666.9
8708	8	1598.3	8741	8	1632.5	8775	8	1667.9
8709	8	1599.4	8742	8	1633.5	8776	8	1669.0
			8743	8	1634.5	8777	8	1670.0
8710	8	1600.4	8744	8	1635.5	8778	8	1671.0
8711	8	1601.4	8745	8	1636.5	8779	8	1672.1
8712	8	1602.5	8746	8	1637.5			
8713	8	1603.5	8747	8	1638.5	8780	8	1673.1
8714	8	1604.5	8748	8	1639.5	8781	8	1674.2
8715	8	1605.6	8749	8	1640.8	8782	8	1675.2
8716	8	1606.6				8783	8	1676.3
8717	8	1607.6	8750	8	1641.9	8784	8	1677.3
8718	8	1608.7	8751	8	1642.9	8785	8	1678.3
8719	8	1609.7	8752	8	1643.9	8786	8	1679.4
			8753	8	1645.0	8787	8	1680.4
8720	8	1610.7	8754	8	1646.0	8788	8	1681.5
8721	8	1611.8	8755	8	1647.1	8789	8	1682.5
8722	8	1612.8	8756	8	1648.1			
8723	8	1613.8	8757	8	1649.1	8790	8	1683.6
8724	8	1614.9	8758	8	1650.2	8791	8	1684.6
8725	8	1615.9	8759	8	1651.2	8792	8	1685.7
8726	8	1616.9				8793	8	1686.7
8727	8	1618.0	8760	8	1652.3	8794	8	1687.8
8728	8	1619.0	8761	8	1653.3	8795	8	1688.8
8729	8	1620.0	8762	8	1654.3	8796	8	1689.9
			8763	8	1655.4	8797	8	1690.9
8730	8	1621.1	8764	8	1656.4	8798	8	1692.0

**TABLE 6-10. CALIBRATION OF HIGH FREQUENCY OSCILLATOR
2000KC TO 18100KC**

Frequency: 8800-8900 Kc

Freq.	A	B	Freq.	A	B	Freq.	A	B
8800	8	1694.1	8834	8	1729.9	8868	8	1766.0
8801	8	1695.1	8835	8	1731.0	8869	8	1767.1
8802	8	1696.2	8836	8	1732.0			
8803	8	1697.2	8837	8	1733.1	8870	8	1768.2
8804	8	1698.3	8838	8	1734.1	8871	8	1769.3
8805	8	1699.3	8839	8	1735.2	8872	8	1770.3
8806	8	1700.4				8873	8	1771.4
8807	8	1701.4	8840	8	1736.2	8874	8	1772.5
8808	8	1702.5	8841	8	1737.3	8875	8	1773.5
8809	8	1703.5	8842	8	1738.4	8876	8	1774.6
			8843	8	1739.4	8877	8	1775.7
8810	8	1704.6	8844	8	1740.5	8878	8	1776.7
8811	8	1705.7	8845	8	1741.5	8879	8	1777.8
8812	8	1706.7	8846	8	1742.6			
8813	8	1707.8	8847	8	1743.6	8880	8	1778.9
8814	8	1708.8	8848	8	1744.7	8881	8	1780.0
8815	8	1709.9	8849	8	1745.7	8882	8	1781.0
8816	8	1710.9				8883	8	1782.1
8817	8	1712.0	8850	8	1746.8	8884	8	1783.2
8818	8	1713.0	8851	8	1747.9	8885	8	1784.3
8819	8	1714.1	8852	8	1748.9	8886	8	1785.3
			8853	8	1750.0	8887	8	1786.4
8820	8	1715.1	8854	8	1751.1	8888	8	1787.5
8821	8	1716.2	8855	8	1752.1	8889	8	1788.6
8822	8	1717.2	8856	8	1753.2			
8823	8	1718.3	8857	8	1754.3	8890	8	1789.6
8824	8	1719.3	8858	8	1755.4	8891	8	1790.7
8825	8	1720.4	8859	8	1756.4	8892	8	1791.8
8826	8	1721.5				8893	8	1792.9
8827	8	1722.5	8860	8	1757.5	8894	8	1794.0
8828	8	1723.6	8861	8	1758.6	8895	8	1795.0
8829	8	1724.6	8862	8	1759.6	8896	8	1796.1
			8863	8	1760.7	8897	8	1797.2
8830	8	1725.7	8864	8	1761.8	8898	8	1798.3
8831	8	1726.7	8865	8	1762.8	8899	8	1799.3
8832	8	1727.8	8866	8	1763.9			
8833	8	1728.8	8867	8	1765.0	8900	8	1800.4

Use check point at 8700 or 9000 Kc, whichever is nearer

Frequency: 9000-9100 Kc

Freq.	A	B	Freq.	A	B	Freq.	A	B
9000	9	180.1	9034	9	128.1	9068	9	156.0
9001	9	101.0	9035	9	128.9	9069	9	156.8
9002	9	101.8	9036	9	129.7			
9003	9	102.6	9037	9	130.6	9070	9	157.6
9004	9	103.4	9038	9	131.4	9071	9	158.4
9005	9	104.3	9039	9	132.2	9072	9	159.2
9006	9	105.1				9073	9	160.1
9007	9	105.9	9040	9	133.0	9074	9	160.9
9008	9	106.7	9041	9	133.8	9075	9	161.7
9009	9	107.5	9042	9	134.7	9076	9	162.5
			9043	9	135.5	9077	9	163.3
9010	9	108.4	9044	9	136.3	9078	9	164.2
9011	9	109.2	9045	9	137.1	9079	9	165.0
9012	9	110.0	9046	9	137.9			
9013	9	110.8	9047	9	138.8	9080	9	165.8
9014	9	111.6	9048	9	139.6	9081	9	166.6
9015	9	112.5	9049	9	140.4	9082	9	167.4
9016	9	113.3				9083	9	168.3
9017	9	114.1	9050	9	141.2	9084	9	169.1
9018	9	114.9	9051	9	142.0	9085	9	169.9
9019	9	115.8	9052	9	142.9	9086	9	170.7
			9053	9	143.7	9087	9	171.5
9020	9	116.6	9054	9	144.5	9088	9	172.3
9021	9	117.4	9055	9	145.3	9089	9	173.2
9022	9	118.2	9056	9	146.1			
9023	9	119.0	9057	9	147.0	9090	9	174.0
9024	9	119.9	9058	9	147.8	9091	9	174.8
9025	9	120.7	9059	9	148.6	9092	9	175.6
9026	9	121.5				9093	9	176.4
9027	9	122.3	9060	9	149.4	9094	9	177.2
9028	9	123.2	9061	9	150.2	9095	9	178.0
9029	9	124.0	9062	9	151.1	9096	9	178.9
			9063	9	151.9	9097	9	179.7
9030	9	124.8	9064	9	152.7	9098	9	180.5
9031	9	125.6	9065	9	153.5	9099	9	181.3
9032	9	126.4	9066	9	154.3			
9033	9	127.3	9067	9	155.1	9100	9	182.1

Use check point at 9000 Kc

Frequency: 8900-9000 Kc

Freq.	A	B	Freq.	A	B	Freq.	A	B
8900	8	1800.4	8934	8	1837.2	8968	8	1874.6
8901	8	1801.5	8935	8	1838.3	8969	8	1875.7
8902	8	1802.6	8936	8	1839.3			
8903	8	1803.6	8937	8	1840.4	8970	8	1876.8
8904	8	1804.7	8938	8	1841.5	8971	8	1877.9
8905	8	1805.8	8939	8	1842.6	8972	8	1879.0
8906	8	1806.9				8973	8	1880.1
8907	8	1808.0	8940	8	1843.7	8974	8	1881.2
8908	8	1809.0	8941	8	1844.8	8975	8	1882.3
8909	8	1810.1	8942	8	1845.9	8976	8	1883.4
			8943	8	1847.0	8977	8	1884.5
8910	8	1811.2	8944	8	1848.1	8978	8	1885.6
8911	8	1812.3	8945	8	1849.2	8979	8	1886.7
8912	8	1813.3	8946	8	1850.3			
8913	8	1814.4	8947	8	1851.4	8980	8	1887.8
8914	8	1815.5	8948	8	1852.5	8981	8	1888.9
8915	8	1816.6	8949	8	1853.6	8982	8	1890.1
8916	8	1817.7				8983	8	1891.2
8917	8	1818.8	8950	8	1854.7	8984	8	1892.3
8918	8	1819.8	8951	8	1855.8	8985	8	1893.4
8919	8	1820.9	8952	8	1856.9	8986	8	1894.5
			8953	8	1858.0	8987	8	1895.6
8920	8	1822.0	8954	8	1859.1	8988	8	1896.7
8921	8	1823.1	8955	8	1860.2	8989	8	1897.8
8922	8	1824.2	8956	8	1861.3			
8923	8	1825.3	8957	8	1862.4	8990	8	1898.9
8924	8	1826.3	8958	8	1863.5	8991	8	1900.0
8925	8	1827.4	8959	8	1864.6	8992	8	1901.1
8926	8	1828.5				8993	8	1902.2
8927	8	1829.6	8960	8	1865.7	8994	8	1903.4
8928	8	1830.7	8961	8	1866.8	8995	8	1904.5
8929	8	1831.8	8962	8	1867.9	8996	8	1905.6
			8963	8	1869.0	8997	8	1906.7
8930	8	1832.8	8964	8	1870.1	8998	8	1907.8
8931	8	1833.9	8965	8	1871.2	8999	8	1908.9
8932	8	1835.0	8966	8	1872.3			
8933	8	1836.1	8967	8	1873.5	9000	8	1910.0

Use check point at 9000 Kc

Frequency: 9100-9200 Kc

Freq.	A	B	Freq.	A	B	Freq.	A	B
9100	9	182.1	9134	9	209.9	9168	9	237.7
9101	9	183.0	9135	9	210.7	9169	9	238.5
9102	9	183.8	9136	9	211.5			
9103	9	184.6	9137	9	212.3	9170	9	239.3
9104	9	185.4	9138	9	213.2	9171	9	240.1
9105	9	186.2	9139	9	214.0	9172	9	240.9
9106	9	187.0				9173	9	241.7
9107	9	187.9	9140	9	214.8	9174	9	242.5
9108	9	188.7	9141	9	215.6	9175	9	243.4
9109	9	189.5	9142	9	216.4	9176	9	244.2
			9143	9	217.2	9177	9	245.0
9110	9	190.3	9144	9	218.1	9178	9	245.8
9111	9	191.1	9145	9	218.9	9179	9	246.6
9112	9	191.9	9146	9	219.7			
9113	9	192.8	9147	9	220.5	9180	9	247.4
9114	9	193.6	9148	9	221.3	9181	9	248.3
9115	9	194.4	9149	9	222.1	9182	9	249.1
9116	9	195.2				9183	9	249.9
9117	9	196.0	9150	9	223.0	9184	9	250.7
9118	9	196.8	9151	9	223.8	9185	9	251.5
9119	9	197.6	9152	9	224.6	9186	9	252.4
			9153	9	225.4	9187	9	253.2
9120	9	198.5	9154	9	226.2	9188	9	254.0
9121	9	199.3	9155	9	227.0	9189	9	254.8
9122	9	200.1	9156	9	227.9			
9123	9	200.9	9157	9	228.7	9190	9	255.6
9124	9	201.7	9158	9	229.5	9191	9	256.5
9125	9	202.5	9159	9	230.3	9192	9	257.3
9126	9	203.4				9193	9	258.1
9127	9	204.2	9160	9	231.1	9194	9	258.9
9128	9	205.0	9161	9	231.9	9195	9	259.7
9129	9	205.8	9162	9	232.8	9196	9	260.6
			9163	9	233.6	9197	9	261.4
9130	9	206.6	9164	9	234.4	9198	9	262.2
9131	9	207.4	9165	9	235.2	9199	9	263.0
9132	9	208.3	9166	9	236.0			
9133	9	209.1	9167					

**TABLE 6-10. CALIBRATION OF HIGH FREQUENCY OSCILLATOR
2000Kc TO 18100Kc**

Frequency: 9200-9300 Kc						Frequency: 9400-9500 Kc					
Freq.	A	B	Freq.	A	B	Freq.	A	B	Freq.	A	B
9200	9	263.8	9234	9	291.7	9268	9	319.6	9400	9	428.2
9201	9	264.6	9235	9	292.5	9269	9	320.4	9401	9	429.0
9202	9	265.5	9236	9	293.3				9402	9	429.8
9203	9	266.3	9237	9	294.2	9270	9	321.2	9403	9	430.7
9204	9	267.1	9238	9	295.0	9271	9	322.1	9404	9	431.5
9205	9	267.9	9239	9	295.8	9272	9	322.9	9405	9	432.3
9206	9	268.7				9273	9	323.7	9406	9	433.2
9207	9	269.6	9240	9	296.6	9274	9	324.5	9407	9	434.0
9208	9	270.4	9241	9	297.4	9275	9	325.3	9408	9	434.8
9209	9	271.2	9242	9	298.3	9276	9	326.2	9409	9	435.6
			9243	9	299.1	9277	9	327.0			
9210	9	272.0	9244	9	299.9	9278	9	327.8	9410	9	436.5
9211	9	272.8	9245	9	300.7	9279	9	328.6	9411	9	437.3
9212	9	273.7	9246	9	301.5				9412	9	438.1
9213	9	274.5	9247	9	302.4	9280	9	329.4	9413	9	438.9
9214	9	275.3	9248	9	303.2	9281	9	330.3	9414	9	439.8
9215	9	276.1	9249	9	304.0	9282	9	331.1	9415	9	440.6
9216	9	276.9				9283	9	331.9	9416	9	441.4
9217	9	277.8	9250	9	304.8	9284	9	332.7	9417	9	442.3
9218	9	278.6	9251	9	305.6	9285	9	333.5	9418	9	443.1
9219	9	279.4	9252	9	306.5	9286	9	334.4	9419	9	443.9
			9253	9	307.3	9287	9	335.2			
9220	9	280.2	9254	9	308.1	9288	9	336.0	9420	9	444.7
9221	9	281.0	9255	9	308.9	9289	9	336.8	9421	9	445.6
9222	9	281.8	9256	9	309.7				9422	9	446.4
9223	9	282.7	9257	9	310.6	9290	9	337.6	9423	9	447.2
9224	9	283.5	9258	9	311.4	9291	9	338.5	9424	9	448.0
			9259	9	312.2	9292	9	339.3	9425	9	448.9
9225	9	284.3				9293	9	340.1	9426	9	449.7
9226	9	285.1	9260	9	313.0	9294	9	340.9	9427	9	450.5
9227	9	285.9	9261	9	313.9	9295	9	341.7	9428	9	451.4
9228	9	286.8	9262	9	314.7	9296	9	342.6	9429	9	452.2
9229	9	287.6	9263	9	315.5	9297	9	343.4			
			9264	9	316.3	9298	9	344.2	9430	9	453.0
9230	9	288.4	9265	9	317.1	9299	9	345.0	9431	9	453.8
9231	9	289.2	9266	9	318.0				9432	9	454.7
9232	9	290.0	9267	9	318.8	9300	9	345.8	9433	9	455.5
9233	9	290.9									

Use check point at 9000 or 9450 Kc, whichever is nearer

Use check point at 9450 Kc

Frequency: 9300-9400 Kc					
Freq.	A	B	Freq.	A	B
9300	9	345.8	9334	9	373.7
9301	9	346.7	9335	9	374.5
9302	9	347.5	9336	9	375.4
9303	9	348.3	9337	9	376.2
9304	9	349.1	9338	9	377.0
9305	9	349.9	9339	9	377.8
9306	9	350.8			
9307	9	351.6	9340	9	378.6
9308	9	352.4	9341	9	379.5
9309	9	353.2	9342	9	380.3
			9343	9	381.1
9310	9	354.0	9344	9	381.9
9311	9	354.9	9345	9	382.7
9312	9	355.7	9346	9	383.6
9313	9	356.5	9347	9	384.4
9314	9	357.3	9348	9	385.2
9315	9	358.1	9349	9	386.0
9316	9	359.0			
9317	9	359.8	9350	9	386.8
9318	9	360.6	9351	9	387.7
9319	9	361.4	9352	9	388.5
			9353	9	389.3
9320	9	362.2	9354	9	390.1
9321	9	363.1	9355	9	390.9
9322	9	363.9	9356	9	391.8
9323	9	364.7	9357	9	392.6
9324	9	365.5	9358	9	393.4
9325	9	366.3	9359	9	394.2
9326	9	367.2			
9327	9	368.0	9360	9	395.1
9328	9	368.8	9361	9	395.9
9329	9	369.6	9362	9	396.7
			9363	9	397.5
9330	9	370.4	9364	9	398.4
9331	9	371.3	9365	9	399.2
9332	9	372.1	9366	9	400.0
9333	9	372.9	9367	9	400.8

Use check point at 9450 Kc

Frequency: 9500-9600 Kc					
Freq.	A	B	Freq.	A	B
9500	9	510.9	9534	9	539.1
9501	9	511.7	9535	9	540.0
9502	9	512.5	9536	9	540.8
9503	9	513.4	9537	9	541.6
9504	9	514.2	9538	9	542.5
9505	9	515.0	9539	9	543.3
9506	9	515.9			
9507	9	516.7	9540	9	544.1
9508	9	517.5	9541	9	544.9
9509	9	518.4	9542	9	545.8
			9543	9	546.6
9510	9	519.2	9544	9	547.4
9511	9	520.0	9545	9	548.3
9512	9	520.8	9546	9	549.1
9513	9	521.7	9547	9	549.9
9514	9	522.5	9548	9	550.7
9515	9	523.3	9549	9	551.6
9516	9	524.2			
9517	9	525.0	9550	9	552.4
9518	9	525.8	9551	9	553.2
9519	9	526.7	9552	9	554.1
			9553	9	554.9
9520	9	527.5	9554	9	555.7
9521	9	528.3	9555	9	556.5
9522	9	529.2	9556	9	557.4
9523	9	530.0	9557	9	558.2
9524	9	530.8	9558	9	559.0
9525	9	531.7	9559	9	559.9
9526	9	532.5			
9527	9	533.3	9560	9	560.7
9528	9	534.1	9561	9	561.5
9529	9	535.0	9562	9	562.4
			9563	9	563.2
9530	9	535.8	9564	9	564.0
9531	9	536.6	9565	9	564.8
9532	9	537.5	9566	9	565.7
9533	9	538.3	9567	9	566.5

Use check point at 9450 Kc

**TABLE 6-10. CALIBRATION OF HIGH FREQUENCY OSCILLATOR
200KC TO 18100K**

Frequency: 9600-9700 Kc						Frequency: 9800-9900 Kc								
Freq.	A	B	Freq.	A	B	Freq.	A	B	Freq.	A	B	Freq.	A	B
9600	9	593.9	9634	9	622.2	9668	9	650.4	9800	9	760.1	9834	9	788.3
9601	9	594.7	9635	9	623.0	9669	9	651.2	9801	9	761.0	9835	9	789.1
9602	9	595.5	9636	9	623.8				9802	9	761.8	9836	9	790.0
9603	9	596.4	9637	9	624.6	9670	9	652.1	9803	9	762.6	9837	9	790.8
9604	9	597.2	9638	9	625.5	9671	9	652.9	9804	9	763.5	9838	9*	791.6
9605	9	598.0	9639	9	626.3	9672	9	653.7	9805	9	764.3	9839	9	792.4
9606	9	598.9				9673	9	654.6	9806	9	765.1			
9607	9	599.7	9640	9	627.1	9674	9	655.4	9807	9	766.0	9840	9	793.3
9608	9	600.5	9641	9	628.0	9675	9	656.2	9808	9	766.8	9841	9	794.1
9609	9	601.4	9642	9	628.8	9676	9	657.1	9809	9	767.6	9842	9	794.9
			9643	9	629.6	9677	9	657.9				9843	9	795.7
9610	9	602.2	9644	9	630.5	9678	9	658.7	9810	9	768.5	9844	9	796.6
9611	9	603.0	9645	9	631.3	9679	9	659.6	9811	9	769.3	9845	9	797.4
9612	9	603.9	9646	9	632.1				9812	9	770.1	9846	9	798.2
9613	9	604.7	9647	9	633.0	9680	9	660.4	9813	9	770.9	9847	9	799.1
9614	9	605.5	9648	9	633.8	9681	9	661.2	9814	9	771.8	9848	9	799.9
9615	9	606.4	9649	9	634.6	9682	9	662.0	9815	9	772.6	9849	9	800.7
9616	9	607.2				9683	9	662.9	9816	9	773.4			
9617	9	608.0	9650	9	635.5	9684	9	663.7	9817	9	774.2	9850	9	801.5
9618	9	608.9	9651	9	636.3	9685	9	664.5	9818	9	775.1	9851	9	802.4
9619	9	609.7	9652	9	637.1	9686	9	665.4	9819	9	775.9	9852	9	803.2
			9653	9	637.9	9687	9	666.2				9853	9	804.0
9620	9	610.5	9654	9	638.8	9688	9	667.0	9820	9	776.7	9854	9	804.8
9621	9	611.3	9655	9	639.6	9689	9	667.9	9821	9	777.5	9855	9	805.7
9622	9	612.2	9656	9	640.4				9822	9	778.4	9856	9	806.5
9623	9	613.0	9657	9	641.3	9690	9	668.7	9823	9	779.2	9857	9	807.3
9624	9	613.8	9658	9	642.1	9691	9	669.5	9824	9	780.0	9858	9	808.2
9625	9	614.7	9659	9	642.9	9692	9	670.3	9825	9	780.9	9859	9	809.0
9626	9	615.5				9693	9	671.2	9826	9	781.7			
9627	9	616.3	9660	9	643.8	9694	9	672.0	9827	9	782.5	9860	9	809.8
9628	9	617.2	9661	9	644.6	9695	9	672.8	9828	9	783.3	9861	9	810.6
9629	9	618.0	9662	9	645.4	9696	9	673.7	9829	9	784.2	9862	9	811.5
			9663	9	646.3	9697	9	674.5				9863	9	812.3
9630	9	618.8	9664	9	647.1	9698	9	675.3	9830	9	785.0	9864	9	813.1
9631	9	619.7	9665	9	647.9	9699	9	676.2	9831	9	785.8	9865	9	814.0
9632	9	620.5	9666	9	648.7				9832	9	786.6	9866	9	814.8
9633	9	621.3	9667	9	649.6	9700	9	677.0	9833	9	787.5	9867	9	815.6

Use check point at 9450 or 9900 Kc, whichever is nearer

Use check point at 9900 Kc

Frequency: 9700-9800 Kc						Frequency: 9900-10000 Kc								
Freq.	A	B	Freq.	A	B	Freq.	A	B	Freq.	A	B	Freq.	A	B
9700	9	677.0	9734	9	705.2	9768	9	733.5	9900	9	843.0	9934	9	871.0
9701	9	677.8	9735	9	706.0	9769	9	734.3	9901	9	843.8	9935	9	871.9
9702	9	678.6	9736	9	706.9				9902	9	844.7	9936	9	872.7
9703	9	679.5	9737	9	707.7	9770	9	735.1	9903	9	845.5	9937	9	873.5
9704	9	680.3	9738	9	708.5	9771	9	736.0	9904	9	846.3	9938	9	874.3
9705	9	681.1	9739	9	709.4	9772	9	736.8	9905	9	847.1	9939	9	875.2
9706	9	682.0				9773	9	737.6	9906	9	847.9			
9707	9	682.8	9740	9	710.2	9774	9	738.5	9907	9	848.8	9940	9	876.0
9708	9	683.6	9741	9	711.0	9775	9	739.3	9908	9	849.6	9941	9	876.8
9709	9	684.5	9742	9	711.9	9776	9	740.1	9909	9	850.4	9942	9	877.6
			9743	9	712.7	9777	9	741.0				9943	9	878.5
9710	9	685.3	9744	9	713.5	9778	9	741.8	9910	9	851.2	9944	9	879.3
9711	9	686.1	9745	9	714.4	9779	9	742.6	9911	9	852.1	9945	9	880.1
9712	9	686.9	9746	9	715.2				9912	9	852.9	9946	9	880.9
9713	9	687.8	9747	9	716.0	9780	9	743.5	9913	9	853.7	9947	9	881.8
9714	9	688.6	9748	9	716.9	9781	9	744.3	9914	9	854.5	9948	9	882.6
9715	9	689.4	9749	9	717.7	9782	9	745.1	9915	9	855.4	9949	9	883.4
9716	9	690.3				9783	9	746.0	9916	9	856.2			
9717	9	691.1	9750	9	718.5	9784	9	746.8	9917	9	857.0	9950	9	884.2
9718	9	691.9	9751	9	719.3	9785	9	747.6	9918	9	857.8	9951	9	885.1
9719	9	692.8	9752	9	720.2	9786	9	748.5	9919	9	858.7	9952	9	885.9
			9753	9	721.0	9787	9	749.3				9953	9	886.7
9720	9	693.6	9754	9	721.8	9788	9	750.1	9920	9	859.5	9954	9	887.5
9721	9	694.4	9755	9	722.7	9789	9	751.0	9921	9	860.3	9955	9	888.4
9722	9	695.2	9756	9	723.5				9922	9	861.1	9956	9	889.2
9723	9	696.1	9757	9	724.3	9790	9	751.8	9923	9	862.0	9957	9	890.0
9724	9	696.9	9758	9	725.2	9791	9	752.6	9924	9	862.8	9958	9	890.8
9725	9	697.7	9759	9	726.0	9792	9	753.5	9925	9	863.6	9959	9	891.7
9726	9	698.6				9793	9	754.3	9926	9	864.4			
9727	9	699.4	9760	9	726.8	9794	9	755.1	9927	9	865.3	9960	9	892.5
9728	9	700.2	9761	9	727.7	9795	9	756.0	9928	9	866.1	9961	9	893.3
9729	9	701.1	9762	9	728.5	9796	9	756.8	9929	9	866.9	9962	9	894.1
			9763	9	729.3	9797	9	757.6				9963	9	895.0
9730	9	701.9	9764	9	730.1	9798	9	758.5	9930	9	867.7	9964	9	895.8
9731	9	702.7	9765	9	731.0	9799	9	759.3	9931	9	868.6	9965	9	896.6
9732	9	703.6	9766	9	731.8				9932	9	869.4	9966	9	897.4
9733	9	704.4	9767	9	732.6	9800	9	760.1	9933	9	870.2	9967	9	898.3

Use check point at 9900 Kc

Use check point at 9900 Kc

**TABLE 6-10. CALIBRATION OF HIGH FREQUENCY OSCILLATOR
2000KC TO 18100KC**

Frequency: 10000-10100 Kc						Frequency: 10200-10300 Kc								
Freq.	A	B	Freq.	A	B	Freq.	A	B	Freq.	A	B	Freq.	A	B
10000	9	925.5	10034	9	953.5	10068	9	981.4	10200	9	1089.7	10234	9	1117.4
10001	9	926.3	10035	9	954.3	10069	9	982.2	10201	9	1090.5	10235	9	1118.2
10002	9	927.1	10036	9	955.2				10202	9	1091.3	10236	9	1119.0
10003	9	928.0	10037	9	956.0	10070	9	983.0	10203	9	1092.1	10237	9	1119.9
10004	9	928.8	10038	9	956.8	10071	9	983.9	10204	9	1092.9	10238	9	1120.7
10005	9	929.6	10039	9	957.6	10072	9	984.7	10205	9	1093.8	10239	9	1121.5
10006	9	930.4				10073	9	985.5	10206	9	1094.6			
10007	9	931.3	10040	9	958.4	10074	9	986.3	10207	9	1095.4	10240	9	1122.3
10008	9	932.1	10041	9	959.3	10075	9	987.1	10208	9	1096.2	10241	9	1123.1
10009	9	932.9	10042	9	960.1	10076	9	988.0	10209	9	1097.0	10242	9	1123.9
			10043	9	960.9	10077	9	988.8				10243	9	1124.7
10010	9	933.7	10044	9	961.7	10078	9	989.6	10210	9	1097.8	10244	9	1125.6
10011	9	934.6	10045	9	962.5	10079	9	990.4	10211	9	1098.6	10245	9	1126.4
10012	9	935.4	10046	9	963.4				10212	9	1099.5	10246	9	1127.2
10013	9	936.2	10047	9	964.2	10080	9	991.2	10213	9	1100.3	10247	9	1128.0
10014	9	937.0	10048	9	965.0	10081	9	992.1	10214	9	1101.1	10248	9	1128.8
10015	9	937.8	10049	9	965.8	10082	9	992.9	10215	9	1101.9	10249	9	1129.6
10016	9	938.7				10083	9	993.7	10216	9	1102.7			
10017	9	939.5	10050	9	966.6	10084	9	994.5	10217	9	1103.5	10250	9	1130.5
10018	9	940.3	10051	9	967.5	10085	9	995.4	10218	9	1104.4	10251	9	1131.3
10019	9	941.1	10052	9	968.3	10086	9	996.2	10219	9	1105.2	10252	9	1132.1
			10053	9	969.1	10087	9	997.0				10253	9	1132.9
10020	9	942.0	10054	9	969.9	10088	9	997.8	10220	9	1106.0	10254	9	1133.7
10021	9	942.8	10055	9	970.7	10089	9	998.6	10221	9	1106.8	10255	9	1134.5
10022	9	943.6	10056	9	971.6				10222	9	1107.6	10256	9	1135.3
10023	9	944.4	10057	9	972.4	10090	9	999.5	10223	9	1108.4	10257	9	1136.2
10024	9	945.3	10058	9	973.2	10091	9	1000.3	10224	9	1109.2	10258	9	1137.0
10025	9	946.1	10059	9	974.0	10092	9	1001.1	10225	9	1110.1	10259	9	1137.8
10026	9	946.9				10093	9	1001.9	10226	9	1110.9			
10027	9	947.7	10060	9	974.8	10094	9	1002.8	10227	9	1111.7	10260	9	1138.6
10028	9	948.6	10061	9	975.7	10095	9	1003.6	10228	9	1112.5	10261	9	1139.4
10029	9	949.4	10062	9	976.5	10096	9	1004.4	10229	9	1113.3	10262	9	1140.2
			10063	9	977.3	10097	9	1005.2				10263	9	1141.0
10030	9	950.2	10064	9	978.1	10098	9	1006.0	10230	9	1114.1	10264	9	1141.9
10031	9	951.0	10065	9	978.9	10099	9	1006.9	10231	9	1115.0	10265	9	1142.7
10032	9	951.9	10066	9	979.8				10232	9	1115.8	10266	9	1143.5
10033	9	952.7	10067	9	980.6	10100	9	1007.7	10233	9	1116.6	10267	9	1144.3

Use check point at 9900 Kc

Use check point at 10350 Kc

Frequency: 10100-10200 Kc					
Freq.	A	B	Freq.	A	B
10100	9	1007.7	10134	9	1035.7
10101	9	1008.5	10135	9	1036.5
10102	9	1009.3	10136	9	1037.3
10103	9	1010.2	10137	9	1038.1
10104	9	1011.0	10138	9	1038.9
10105	9	1011.8	10139	9	1039.8
10106	9	1012.6			
10107	9	1013.5	10140	9	1040.6
10108	9	1014.3	10141	9	1041.4
10109	9	1015.1	10142	9	1042.2
			10143	9	1043.1
10110	9	1015.9	10144	9	1043.9
10111	9	1016.7	10145	9	1044.7
10112	9	1017.6	10146	9	1045.5
10113	9	1018.4	10147	9	1046.3
10114	9	1019.2	10148	9	1047.2
10115	9	1020.0	10149	9	1048.0
10116	9	1020.9			
10117	9	1021.7	10150	9	1048.8
10118	9	1022.5	10151	9	1049.6
10119	9	1023.3	10152	9	1050.5
			10153	9	1051.3
10120	9	1024.1	10154	9	1052.1
10121	9	1025.0	10155	9	1052.9
10122	9	1025.8	10156	9	1053.7
10123	9	1026.6	10157	9	1054.6
10124	9	1027.4	10158	9	1055.4
			10159	9	1056.2
10125	9	1028.3			
10126	9	1029.1			
10127	9	1029.9	10160	9	1057.0
10128	9	1030.7	10161	9	1057.9
10129	9	1031.5	10162	9	1058.7
			10163	9	1059.5
10130	9	1032.4	10164	9	1060.3
10131	9	1033.2	10165	9	1061.1
10132	9	1034.0	10166	9	1062.0
10133	9	1034.8	10167	9	1062.8
			10200	9	1089.7

Use check point at 9900 or 10350 Kc, whichever is nearer

Frequency: 10300-10400 Kc					
Freq.	A	B	Freq.	A	B
10300	9	1171.2	10334	9	1198.8
10301	9	1172.0	10335	9	1199.6
10302	9	1172.8	10336	9	1200.4
10303	9	1173.6	10337	9	1201.2
10304	9	1174.4	10338	9	1202.0
10305	9	1175.2	10339	9	1202.8
10306	9	1176.0			
10307	9	1176.8	10340	9	1203.7
10308	9	1177.7	10341	9	1204.5
10309	9	1178.5	10342	9	1205.3
			10343	9	1206.1
10310	9	1179.3	10344	9	1206.9
10311	9	1180.1	10345	9	1207.7
10312	9	1180.9	10346	9	1208.5
10313	9	1181.7	10347	9	1209.3
10314	9	1182.5	10348	9	1210.1
10315	9	1183.4	10349	9	1211.0
10316	9	1184.2			
10317	9	1185.0	10350	9	1211.8
10318	9	1185.8	10351	9	1212.6
10319	9	1186.6	10352	9	1213.4
			10353	9	1214.2
10320	9	1187.4	10354	9	1215.0
10321	9	1188.2	10355	9	1215.8
10322	9	1189.0	10356	9	1216.6
10323	9	1189.8	10357	9	1217.5
10324	9	1190.7	10358	9	1218.3
10325	9	1191.5	10359	9	1219.1
10326	9	1192.3			
10327	9	1193.1	10360	9	1219.9
10328	9	1193.9	10361	9	1220.7
10329	9	1194.7	10362	9	1221.5
			10363	9	1222.3
10330	9	1195.5	10364	9	1223.1
10331	9	1196.3	10365	9	1224.0
10332	9	1197.2	10366	9	1224.8
10333	9	1198.0	10367	9	1225.6
			10400	9	1252.4

Use check point at 10350 Kc

**TABLE 6-10. CALIBRATION OF HIGH FREQUENCY OSCILLATOR
200KC TO 18100KC**

Frequency: 10400-10500 Kc						Frequency: 10600-10700 Kc								
Freq.	A	B	Freq.	A	B	Freq.	A	B	Freq.	A	B	Freq.	A	B
10400	9	1252.4	10434	9	1280.0	10468	9	1307.7	10600	9	1415.0	10634	9	1442.7
10401	9	1253.2	10435	9	1280.8	10469	9	1308.5	10601	9	1415.9	10635	9	1443.5
10402	9	1254.0	10436	9	1281.6				10602	9	1416.7	10636	9	1444.3
10403	9	1254.8	10437	9	1282.4	10470	9	1309.3	10603	9	1417.5	10637	9	1445.1
10404	9	1255.6	10438	9	1283.2	10471	9	1310.1	10604	9	1418.3	10638	9	1446.0
10405	9	1256.4	10439	9	1284.0	10472	9	1310.9	10605	9	1419.1	10639	9	1446.8
10406	9	1257.2				10473	9	1311.7	10606	9	1419.9			
10407	9	1258.0	10440	9	1284.8	10474	9	1312.6	10607	9	1420.8	10640	9	1447.6
10408	9	1258.9	10441	9	1285.7	10475	9	1313.4	10608	9	1421.6	10641	9	1448.4
10409	9	1259.7	10442	9	1286.5	10476	9	1314.2	10609	9	1422.4	10642	9	1449.2
			10443	9	1287.3	10477	9	1315.0				10643	9	1450.0
10410	9	1260.5	10444	9	1288.1	10478	9	1315.8	10610	9	1423.2	10644	9	1450.8
10411	9	1261.3	10445	9	1288.9	10479	9	1316.6	10611	9	1424.0	10645	9	1451.6
10412	9	1262.1	10446	9	1289.7				10612	9	1424.8	10646	9	1452.4
10413	9	1262.9	10447	9	1290.5	10480	9	1317.4	10613	9	1425.6	10647	9	1453.3
10414	9	1263.7	10448	9	1291.4	10481	9	1318.3	10614	9	1426.5	10648	9	1454.1
10415	9	1264.5	10449	9	1292.2	10482	9	1319.1	10615	9	1427.3	10649	9	1454.9
10416	9	1265.4				10483	9	1319.9	10616	9	1428.1			
10417	9	1266.2	10450	9	1293.0	10484	9	1320.7	10617	9	1428.9	10650	9	1455.7
10418	9	1267.0	10451	9	1293.8	10485	9	1321.5	10618	9	1429.7	10651	9	1456.5
10419	9	1267.8	10452	9	1294.6	10486	9	1322.3	10619	9	1430.5	10652	9	1457.3
			10453	9	1295.4	10487	9	1323.1				10653	9	1458.1
10420	9	1268.6	10454	9	1296.3	10488	9	1324.0	10620	9	1431.4	10654	9	1458.9
10421	9	1269.4	10455	9	1297.1	10489	9	1324.8	10621	9	1432.2	10655	9	1459.7
10422	9	1270.2	10456	9	1297.9				10622	9	1433.0	10656	9	1460.6
10423	9	1271.0	10457	9	1298.7	10490	9	1325.6	10623	9	1433.8	10657	9	1461.4
10424	9	1271.8	10458	9	1299.5	10491	9	1326.4	10624	9	1434.6	10658	9	1462.2
10425	9	1272.7	10459	9	1300.3	10492	9	1327.2	10625	9	1435.4	10659	9	1463.0
10426	9	1273.5				10493	9	1328.0	10626	9	1436.2			
10427	9	1274.3	10460	9	1301.1	10494	9	1328.8	10627	9	1437.0	10660	9	1463.8
10428	9	1275.1	10461	9	1302.0	10495	9	1329.7	10628	9	1437.8	10661	9	1464.6
10429	9	1275.9	10462	9	1302.8	10496	9	1330.5	10629	9	1438.7	10662	9	1465.4
			10463	9	1303.6	10497	9	1331.3				10663	9	1466.2
10430	9	1276.7	10464	9	1304.4	10498	9	1332.1	10630	9	1439.5	10664	9	1467.0
10431	9	1277.5	10465	9	1305.2	10499	9	1332.9	10631	9	1440.3	10665	9	1467.9
10432	9	1278.3	10466	9	1306.0				10632	9	1441.1	10666	9	1468.7
10433	9	1279.2	10467	9	1306.8	10500	9	1333.7	10633	9	1441.9	10667	9	1469.5

Use check point at 10350 Kc

Use check point at 10800 Kc

Frequency: 10500-10600 Kc						Frequency: 10700-10800 Kc								
Freq.	A	B	Freq.	A	B	Freq.	A	B	Freq.	A	B	Freq.	A	B
10500	9	1333.7	10534	9	1361.4	10568	9	1389.0	10700	9	1496.6	10734	9	1524.5
10501	9	1334.5	10535	9	1362.2	10569	9	1389.8	10701	9	1497.4	10735	9	1525.3
10502	9	1335.3	10536	9	1363.0				10702	9	1498.3	10736	9	1526.1
10503	9	1336.2	10537	9	1363.8	10570	9	1390.6	10703	9	1499.1	10737	9	1527.0
10504	9	1337.0	10538	9	1364.6	10571	9	1391.4	10704	9	1499.9	10738	9	1527.8
10505	9	1337.8	10539	9	1365.4	10572	9	1392.2	10705	9	1500.7	10739	9	1528.6
10506	9	1338.6				10573	9	1393.0	10706	9	1501.6			
10507	9	1339.4	10540	9	1366.2	10574	9	1393.8	10707	9	1502.4	10740	9	1529.4
10508	9	1340.2	10541	9	1367.0	10575	9	1394.6	10708	9	1503.2	10741	9	1530.2
10509	9	1341.0	10542	9	1367.9	10576	9	1395.5	10709	9	1504.0	10742	9	1531.1
			10543	9	1368.7	10577	9	1396.3				10743	9	1531.9
10510	9	1341.9	10544	9	1369.5	10578	9	1397.1	10710	9	1504.8	10744	9	1532.7
10511	9	1342.7	10545	9	1370.3	10579	9	1397.9	10711	9	1505.7	10745	9	1533.5
10512	9	1343.5	10546	9	1371.1				10712	9	1506.5	10746	9	1534.3
10513	9	1344.3	10547	9	1371.9	10580	9	1398.7	10713	9	1507.3	10747	9	1535.2
10514	9	1345.1	10548	9	1372.7	10581	9	1399.5	10714	9	1508.1	10748	9	1536.0
10515	9	1345.9	10549	9	1373.5	10582	9	1400.4	10715	9	1508.9	10749	9	1536.8
10516	9	1346.7				10583	9	1401.2	10716	9	1509.8			
10517	9	1347.5	10550	9	1374.3	10584	9	1402.0	10717	9	1510.6	10750	9	1537.6
10518	9	1348.4	10551	9	1375.2	10585	9	1402.8	10718	9	1511.4	10751	9	1538.4
10519	9	1349.2	10552	9	1376.0	10586	9	1403.6	10719	9	1512.2	10752	9	1539.3
			10553	9	1376.8	10587	9	1404.4				10753	9	1540.1
10520	9	1350.0	10554	9	1377.6	10588	9	1405.2	10720	9	1513.0	10754	9	1540.9
10521	9	1350.8	10555	9	1378.4	10589	9	1406.1	10721	9	1513.9	10755	9	1541.7
10522	9	1351.6	10556	9	1379.2				10722	9	1514.7	10756	9	1542.5
10523	9	1352.4	10557	9	1380.0	10590	9	1406.9	10723	9	1515.5	10757	9	1543.4
10524	9	1353.2	10558	9	1380.8	10591	9	1407.7	10724	9	1516.3	10758	9	1544.2
10525	9	1354.1	10559	9	1381.7	10592	9	1408.5	10725	9	1517.1	10759	9	1545.0
10526	9	1354.9				10593	9	1409.3	10726	9	1518.0			
10527	9	1355.7	10560	9	1382.5	10594	9	1410.1	10727	9	1518.8	10760	9	1545.8
10528	9	1356.5	10561	9	1383.3	10595	9	1411.0	10728	9	1519.6	10761	9	1546.7
10529	9	1357.3	10562	9	1384.1	10596	9	1411.8	10729	9	1520.4	10762	9	1547.5
			10563	9	1384.9	10597	9	1412.6				10763	9	1548.3
10530	9	1358.1	10564	9	1385.7	10598	9	1413.4	10730	9	1521.2	10764	9	1549.1
10531	9	1358.9	10565	9	1386.5	10599	9	1414.2	10731	9	1522.1	10765	9	1550.0
10532	9	1359.7	10566	9	1387.3				10732	9	1522.9	10766	9	1550.8
10533	9	1360.6	10567	9	1388.1	10600	9	1415.0	10733	9	1523.7	10767	9	1551.6

Use check point at 10350 or 10800 Kc, whichever is nearer

Use check point at 10800 Kc

**TABLE 6-10. CALIBRATION OF HIGH FREQUENCY OSCILLATOR
2000KC TO 18100KC**

Frequency: 10800—10900 Kc

Freq.	A	B	Freq.	A	B	Freq.	A	B
10800	10	60.0	10834	10	83.2	10868	10	106.3
10801	10	60.7	10835	10	83.8	10869	10	107.0
10802	10	61.4	10836	10	84.5			
10803	10	62.0	10837	10	85.2	10870	10	107.7
10804	10	62.7	10838	10	85.9	10871	10	108.4
10805	10	63.4	10839	10	86.6	10872	10	109.1
10806	10	64.1				10873	10	109.7
10807	10	64.8	10840	10	87.3	10874	10	110.4
10808	10	65.5	10841	10	87.9	10875	10	111.1
10809	10	66.1	10842	10	88.6	10876	10	111.8
			10843	10	89.3	10877	10	112.5
10810	10	66.8	10844	10	90.0	10878	10	113.1
10811	10	67.5	10845	10	90.7	10879	10	113.8
10812	10	68.2	10846	10	91.3			
10813	10	68.9	10847	10	92.0	10880	10	114.5
10814	10	69.5	10848	10	92.7	10881	10	115.2
10815	10	70.2	10849	10	93.4	10882	10	115.9
10816	10	70.9				10883	10	116.6
10817	10	71.6	10850	10	94.1	10884	10	117.2
10818	10	72.3	10851	10	94.7	10885	10	117.9
10819	10	72.9	10852	10	95.4	10886	10	118.6
			10853	10	96.1	10887	10	119.3
10820	10	73.6	10854	10	96.8	10888	10	120.0
10821	10	74.3	10855	10	97.5	10889	10	120.6
10822	10	75.0	10856	10	98.2			
10823	10	75.7	10857	10	98.8	10890	10	121.3
10824	10	76.4	10858	10	99.5	10891	10	122.0
10825	10	77.0	10859	10	100.2	10892	10	122.7
10826	10	77.7				10893	10	123.4
10827	10	78.4	10860	10	100.9	10894	10	124.0
10828	10	79.1	10861	10	101.6	10895	10	124.7
10829	10	79.8	10862	10	102.2	10896	10	125.4
			10863	10	102.9	10897	10	126.1
10830	10	80.4	10864	10	103.6	10898	10	126.7
10831	10	81.1	10865	10	104.3	10899	10	127.4
10832	10	81.8	10866	10	105.0			
10833	10	82.5	10867	10	105.6	10900	10	128.1

Use check point at 10800 Kc

Frequency: 11000—11100 Kc

Freq.	A	B	Freq.	A	B	Freq.	A	B
11000	10	195.7	11034	10	218.7	11068	10	241.6
11001	10	196.4	11035	10	219.3	11069	10	242.3
11002	10	197.1	11036	10	220.0			
11003	10	197.7	11037	10	220.7	11070	10	243.0
11004	10	198.4	11038	10	221.4	11071	10	243.6
11005	10	199.1	11039	10	222.0	11072	10	244.3
11006	10	199.8				11073	10	245.0
11007	10	200.4	11040	10	222.7	11074	10	245.7
11008	10	201.1	11041	10	223.4	11075	10	246.4
11009	10	201.8	11042	10	224.1	11076	10	247.0
			11043	10	224.7	11077	10	247.7
11010	10	202.5	11044	10	225.4	11078	10	248.4
11011	10	203.1	11045	10	226.1	11079	10	249.1
11012	10	203.8	11046	10	226.8			
11013	10	204.5	11047	10	227.4	11080	10	249.7
11014	10	205.2	11048	10	228.1	11081	10	250.4
11015	10	205.8	11049	10	228.8	11082	10	251.1
11016	10	206.5				11083	10	251.8
11017	10	207.2	11050	10	229.5	11084	10	252.5
11018	10	207.9	11051	10	230.1	11085	10	253.1
11019	10	208.5	11052	10	230.8	11086	10	253.8
			11053	10	231.5	11087	10	254.5
11020	10	209.2	11054	10	232.2	11088	10	255.2
11021	10	209.9	11055	10	232.8	11089	10	255.9
11022	10	210.6	11056	10	233.5			
11023	10	211.2	11057	10	234.2	11090	10	256.5
11024	10	211.9	11058	10	234.9	11091	10	257.2
11025	10	212.6	11059	10	235.5	11092	10	257.9
11026	10	213.3				11093	10	258.6
11027	10	213.9	11060	10	236.2	11094	10	259.2
11028	10	214.6	11061	10	236.9	11095	10	259.9
11029	10	215.3	11062	10	237.6	11096	10	260.6
			11063	10	238.2	11097	10	261.3
11030	10	216.0	11064	10	238.9	11098	10	262.0
11031	10	216.6	11065	10	239.6	11099	10	262.6
11032	10	217.3	11066	10	240.3			
11033	10	218.0	11067	10	240.9	11100	10	263.3

Use check point at 10800 or 11250 Kc, whichever is nearer

Frequency: 10900—11000 Kc

Freq.	A	B	Freq.	A	B	Freq.	A	B
10900	10	128.1	10934	10	151.1	10968	10	174.1
10901	10	128.8	10935	10	151.8	10969	10	174.8
10902	10	129.4	10936	10	152.5			
10903	10	130.1	10937	10	153.2	10970	10	175.4
10904	10	130.8	10938	10	153.8	10971	10	176.1
10905	10	131.5	10939	10	154.5	10972	10	176.8
10906	10	132.2				10973	10	177.5
10907	10	132.8	10940	10	155.2	10974	10	178.1
10908	10	133.5	10941	10	155.9	10975	10	178.8
10909	10	134.2	10942	10	156.5	10976	10	179.5
			10943	10	157.2	10977	10	180.2
10910	10	134.9	10944	10	157.9	10978	10	180.8
10911	10	135.5	10945	10	158.6	10979	10	181.5
10912	10	136.2	10946	10	159.2			
10913	10	136.9	10947	10	159.9	10980	10	182.2
10914	10	137.6	10948	10	160.6	10981	10	182.9
10915	10	138.2	10949	10	161.3	10982	10	183.5
10916	10	138.9				10983	10	184.2
10917	10	139.6	10950	10	161.9	10984	10	184.9
10918	10	140.3	10951	10	162.6	10985	10	185.6
10919	10	141.0	10952	10	163.3	10986	10	186.2
			10953	10	164.0	10987	10	186.9
10920	10	141.6	10954	10	164.6	10988	10	187.6
10921	10	142.3	10955	10	165.3	10989	10	188.3
10922	10	143.0	10956	10	166.0			
10923	10	143.7	10957	10	166.7	10990	10	188.9
10924	10	144.3	10958	10	167.3	10991	10	189.6
10925	10	145.0	10959	10	168.0	10992	10	190.3
10926	10	145.7				10993	10	191.0
10927	10	146.4	10960	10	168.7	10994	10	191.6
10928	10	147.0	10961	10	169.4	10995	10	192.3
10929	10	147.7	10962	10	170.0	10996	10	193.0
			10963	10	170.7	10997	10	193.7
10930	10	148.4	10964	10	171.4	10998	10	194.3
10931	10	149.1	10965	10	172.1	10999	10	195.0
10932	10	149.8	10966	10	172.7			
10933	10	150.4	10967	10	173.4	11000	10	195.7

Use check point at 10800 Kc

Frequency: 11100—11200 Kc

Freq.	A	B	Freq.	A	B	Freq.	A	B
11100	10	263.3	11134	10	286.3	11168	10	309.3
11101	10	264.0	11135	10	287.0	11169	10	310.0
11102	10	264.7	11136	10	287.7			
11103	10	265.4	11137	10	288.4	11170	10	310.7
11104	10	266.0	11138	10	289.0	11171	10	311.4
11105	10	266.7	11139	10	289.7	11172	10	312.1
11106	10	267.4				11173	10	312.7
11107	10	268.1	11140	10	290.4	11174	10	313.4
11108	10	268.7	11141	10	291.1	11175	10	314.1
11109	10	269.4	11142	10	291.7	11176	10	314.8
			11143	10	292.4	11177	10	315.4
11110	10	270.1	11144	10	293.1	11178	10	316.1
11111	10	270.8	11145	10	293.8	11179	10	316.8
11112	10	271.5	11146	10	294.4			
11113	10	272.1	11147	10	295.1	11180	10	317.5
11114	10	272.8	11148	10	295.8	11181	10	318.2
11115	10	273.5	11149	10	296.5	11182	10	318.8
11116	10	274.2				11183	10	319.5
11117	10	274.9	11150	10	297.1	11184	10	320.2
11118	10	275.5	11151	10	297.8	11185	10	320.9
11119	10	276.2	11152	10	298.5	11186	10	321.6
			11153	10	299.2	11187	10	322.2
11120	10	276.9	11154	10	299.8	11188	10	322.9
11121	10	277.6	11155	10	300.5	11189	10	323.6
11122	10	278.2	11156	10	301.2			
11123	10	278.9	11157	10	301.9	11190	10	324.3
11124	10	279.6	11158	10	302.5	11191	10	325.0
11125	10	280.3	11159	10	303.2	11192	10	325.6
11126	10	280.9				11193	10	326.3
11127	10	281.6	11160	10	303.9			

**TABLE 6-10. CALIBRATION OF HIGH FREQUENCY OSCILLATOR
200KC TO 18100Kc**

Frequency: 11200-11300 Kc

Freq.	A	B	Freq.	A	B	Freq.	A	B
11200	10	331.1	11234	10	354.2	11268	10	377.3
11201	10	331.8	11235	10	354.9	11269	10	378.0
11202	10	332.4	11236	10	355.6			
11203	10	333.1	11237	10	356.3	11270	10	378.7
11204	10	333.8	11238	10	357.0	11271	10	379.4
11205	10	334.5	11239	10	357.7	11272	10	380.1
11206	10	335.2				11273	10	380.7
11207	10	335.8	11240	10	358.3	11274	10	381.4
11208	10	336.5	11241	10	359.0	11275	10	382.1
11209	10	337.2	11242	10	359.7	11276	10	382.8
			11243	10	360.4	11277	10	383.4
11210	10	337.9	11244	10	361.1	11278	10	384.1
11211	10	338.6	11245	10	361.7	11279	10	384.8
11212	10	339.2	11246	10	362.4			
11213	10	339.9	11247	10	363.1	11280	10	385.5
11214	10	340.6	11248	10	363.8	11281	10	386.1
11215	10	341.3	11249	10	364.5	11282	10	386.8
11216	10	342.0				11283	10	387.5
11217	10	342.7	11250	10	365.2	11284	10	388.2
11218	10	343.3	11251	10	365.8	11285	10	388.8
11219	10	344.0	11252	10	366.5	11286	10	389.5
			11253	10	367.2	11287	10	390.2
11220	10	344.7	11254	10	367.9	11288	10	390.9
11221	10	345.4	11255	10	368.5	11289	10	391.6
11222	10	346.1	11256	10	369.2			
11223	10	346.7	11257	10	369.9	11290	10	392.2
11224	10	347.4	11258	10	370.6	11291	10	392.9
11225	10	348.1	11259	10	371.3	11292	10	393.6
11226	10	348.8				11293	10	394.3
11227	10	349.5	11260	10	371.9	11294	10	394.9
11228	10	350.2	11261	10	372.6	11295	10	395.6
11229	10	350.8	11262	10	373.3	11296	10	396.3
			11263	10	374.0	11297	10	397.0
11230	10	351.5	11264	10	374.6	11298	10	397.7
11231	10	352.2	11265	10	375.3	11299	10	398.4
11232	10	352.9	11266	10	376.0			
11233	10	353.6	11267	10	376.7	11300	10	399.0

Use check point at 11250 Kc

Frequency: 11400-11500 Kc

Freq.	A	B	Freq.	A	B	Freq.	A	B
11400	10	467.4	11434	10	490.6	11468	10	514.1
11401	10	468.1	11435	10	491.3	11469	10	514.8
11402	10	468.8	11436	10	492.0			
11403	10	469.5	11437	10	492.7	11470	10	515.5
11404	10	470.1	11438	10	493.3	11471	10	516.2
11405	10	470.8	11439	10	494.0	11472	10	516.8
11406	10	471.5				11473	10	517.5
11407	10	472.2	11440	10	494.7	11474	10	518.2
11408	10	472.9	11441	10	495.4	11475	10	518.9
11409	10	473.5	11442	10	496.1	11476	10	519.6
			11443	10	496.8	11477	10	520.3
11410	10	474.2	11444	10	497.5	11478	10	521.0
11411	10	474.9	11445	10	498.2	11479	10	521.7
11412	10	475.6	11446	10	498.9			
11413	10	476.3	11447	10	499.6	11480	10	522.3
11414	10	476.9	11448	10	500.3	11481	10	523.0
11415	10	477.6	11449	10	501.0	11482	10	523.7
11416	10	478.3				11483	10	524.4
11417	10	479.0	11450	10	501.6	11484	10	525.1
11418	10	479.7	11451	10	502.3	11485	10	525.8
11419	10	480.3	11452	10	503.0	11486	10	526.4
			11453	10	503.7	11487	10	527.1
11420	10	481.0	11454	10	504.4	11488	10	527.8
11421	10	481.7	11455	10	505.1	11489	10	528.5
11422	10	482.4	11456	10	505.8			
11423	10	483.1	11457	10	506.5	11490	10	529.2
11424	10	483.7	11458	10	507.2	11491	10	529.9
11425	10	484.4	11459	10	507.9	11492	10	530.6
11426	10	485.1				11493	10	531.2
11427	10	485.8	11460	10	508.6	11494	10	531.9
11428	10	486.5	11461	10	509.2	11495	10	532.6
11429	10	487.1	11462	10	509.9	11496	10	533.3
			11463	10	510.6	11497	10	534.0
11430	10	487.8	11464	10	511.3	11498	10	534.7
11431	10	488.5	11465	10	512.0	11499	10	535.3
11432	10	489.2	11466	10	512.7			
11433	10	489.9	11467	10	513.4	11500	10	536.0

Use check point at 11250 or 11700 Kc, whichever is nearer

Frequency: 11300-11400 Kc

Freq.	A	B	Freq.	A	B	Freq.	A	B
11300	10	399.0	11334	10	422.3	11368	10	445.6
11301	10	399.7	11335	10	423.0	11369	10	446.3
11302	10	400.4	11336	10	423.6			
11303	10	401.1	11337	10	424.3	11370	10	446.9
11304	10	401.8	11338	10	425.0	11371	10	447.6
11305	10	402.5	11339	10	425.7	11372	10	448.3
11306	10	403.1				11373	10	449.0
11307	10	403.8	11340	10	426.4	11374	10	449.7
11308	10	404.5	11341	10	427.1	11375	10	450.4
11309	10	405.2	11342	10	427.7	11376	10	451.1
			11343	10	428.4	11377	10	451.7
11310	10	405.9	11344	10	429.1	11378	10	452.4
11311	10	406.6	11345	10	429.8	11379	10	453.1
11312	10	407.2	11346	10	430.5			
11313	10	407.9	11347	10	431.2	11380	10	453.8
11314	10	408.6	11348	10	431.9	11381	10	454.5
11315	10	409.3	11349	10	432.5	11382	10	455.2
11316	10	410.0				11383	10	455.9
11317	10	410.7	11350	10	433.2	11384	10	456.5
11318	10	411.3	11351	10	433.9	11385	10	457.2
11319	10	412.0	11352	10	434.6	11386	10	457.9
			11353	10	435.3	11387	10	458.6
11320	10	412.7	11354	10	436.0	11388	10	459.3
11321	10	413.4	11355	10	436.7	11389	10	460.0
11322	10	414.1	11356	10	437.3			
11323	10	414.8	11357	10	438.0	11390	10	460.6
11324	10	415.4	11358	10	438.7	11391	10	461.3
11325	10	416.1	11359	10	439.4	11392	10	462.0
11326	10	416.8				11393	10	462.7
11327	10	417.5	11360	10	440.1	11394	10	463.4
11328	10	418.2	11361	10	440.8	11395	10	464.0
11329	10	418.9	11362	10	441.5	11396	10	464.7
			11363	10	442.1	11397	10	465.4
11330	10	419.5	11364	10	442.8	11398	10	466.1
11331	10	420.2	11365	10	443.5	11399	10	466.7
11332	10	420.9	11366	10	444.2			
11333	10	421.6	11367	10	444.9	11400	10	467.4

Use check point at 11250 Kc

Frequency: 11500-11600 Kc

Freq.	A	B	Freq.	A	B	Freq.	A	B
11500	10	536.0	11534	10	559.3	11568	10	582.6
11501	10	536.7	11535	10	560.0	11569	10	583.3
11502	10	537.4	11536	10	560.7			
11503	10	538.1	11537	10	561.4	11570	10	584.0
11504	10	538.8	11538	10	562.1	11571	10	584.7
11505	10	539.5	11539	10	562.7	11572	10	585.4
11506	10	540.1				11573	10	586.1
11507	10	540.8	11540	10	563.4	11574	10	586.8
11508	10	541.5	11541	10	564.1	11575	10	587.5
11509	10	542.2	11542	10	564.8	11576	10	588.2
			11543	10	565.5	11577	10	588.8
11510	10	542.9	11544	10	566.2	11578	10	589.5
11511	10	543.6	11545	10	566.9	11579	10	590.2
11512	10	544.2	11546	10	567.5			
11513	10	544.9	11547	10	568.2	11580	10	590.9
11514	10	545.6	11548	10	568.9	11581	10	591.6
11515	10	546.3	11549	10	569.6	11582	10	592.3
11516	10	547.0				11583	10	593.0
11517	10	547.7	11550	10	570.3	11584	10	593.7
11518	10	548.3	11551	10	571.0	11585	10	594.4
11519	10	549.0	11552	10	571.7	11586	10	595.0
			11553	10	572.3	11587	10	595.7
11520	10	549.7	11554	10	573.0	11588	10	596.4
11521	10	550.4	11555	10	573.7	11589	10	597.1
11522	10	551.1	11556	10	574.4			
11523	10	551.8	11557	10	575.1	11590	10	597.8
11524	10	552.5	11558	10	575.8	11591	10	598.5
11525	10	553.1	11559	10	576.5	11592	10	599.2
11526	10	553.8				11593	10	

**TABLE 6-10. CALIBRATION OF HIGH FREQUENCY OSCILLATOR
2000KC TO 18100KC**

Frequency: 11600-11700 Kc

Freq.	A	B	Freq.	A	B	Freq.	A	B
11600	10	604.7	11634	10	628.1	11668	10	651.4
11601	10	605.4	11635	10	628.8	11669	10	652.1
11602	10	606.1	11636	10	629.4			
11603	10	606.8	11637	10	630.1	11670	10	652.8
11604	10	607.4	11638	10	630.8	11671	10	653.5
11605	10	608.1	11639	10	631.5	11672	10	654.2
11606	10	608.8				11673	10	654.9
11607	10	609.5	11640	10	632.2	11674	10	655.6
11608	10	610.2	11641	10	632.9	11675	10	656.2
11609	10	610.9	11642	10	633.6	11676	10	656.9
			11643	10	634.3	11677	10	657.6
11610	10	611.6	11644	10	634.9	11678	10	658.3
11611	10	612.3	11645	10	635.6	11679	10	659.0
11612	10	612.9	11646	10	636.3			
11613	10	613.6	11647	10	637.0	11680	10	659.7
11614	10	614.3	11648	10	637.7	11681	10	660.4
11615	10	615.0	11649	10	638.4	11682	10	661.1
11616	10	615.7				11683	10	661.7
11617	10	616.4	11650	10	639.1	11684	10	662.4
11618	10	617.1	11651	10	639.8	11685	10	663.1
11619	10	617.8	11652	10	640.4	11686	10	663.8
			11653	10	641.1	11687	10	664.5
11620	10	618.4	11654	10	641.8	11688	10	665.2
11621	10	619.1	11655	10	642.5	11689	10	665.9
11622	10	619.8	11656	10	643.2			
11623	10	620.5	11657	10	643.9	11690	10	666.6
11624	10	621.2	11658	10	644.6	11691	10	667.2
11625	10	621.9	11659	10	645.2	11692	10	667.9
11626	10	622.6				11693	10	668.6
11627	10	623.3	11660	10	645.9	11694	10	669.3
11628	10	623.9	11661	10	646.6	11695	10	670.0
11629	10	624.6	11662	10	647.3	11696	10	670.7
			11663	10	648.0	11697	10	671.4
11630	10	625.3	11664	10	648.7	11698	10	672.0
11631	10	626.0	11665	10	649.4	11699	10	672.7
11632	10	626.7	11666	10	650.1			
11633	10	627.4	11667	10	650.7	11700	10	673.4

Use check point at 11700 Kc

Frequency: 11800-11900 Kc

Freq.	A	B	Freq.	A	B	Freq.	A	B
11800	10	742.1	11834	10	765.3	11868	10	788.6
11801	10	742.8	11835	10	766.0	11869	10	789.3
11802	10	743.4	11836	10	766.6			
11803	10	744.1	11837	10	767.3	11870	10	790.0
11804	10	744.8	11838	10	768.0	11871	10	790.7
11805	10	745.5	11839	10	768.7	11872	10	791.4
11806	10	746.2				11873	10	792.1
11807	10	746.9	11840	10	769.4	11874	10	792.7
11808	10	747.5	11841	10	770.1	11875	10	793.4
11809	10	748.2	11842	10	770.8	11876	10	794.1
			11843	10	771.5	11877	10	794.8
11810	10	748.9	11844	10	772.1	11878	10	795.5
11811	10	749.6	11845	10	772.8	11879	10	796.2
11812	10	750.3	11846	10	773.5			
11813	10	751.0	11847	10	774.2	11880	10	796.9
11814	10	751.6	11848	10	774.9	11881	10	797.6
11815	10	752.3	11849	10	775.6	11882	10	798.2
11816	10	753.0				11883	10	798.9
11817	10	753.7	11850	10	776.3	11884	10	799.6
11818	10	754.4	11851	10	776.9	11885	10	800.3
11819	10	755.0	11852	10	777.6	11886	10	801.0
			11853	10	778.3	11887	10	801.7
11820	10	755.7	11854	10	779.0	11888	10	802.4
11821	10	756.4	11855	10	779.7	11889	10	803.1
11822	10	757.1	11856	10	780.4			
11823	10	757.8	11857	10	781.1	11890	10	803.8
11824	10	758.5	11858	10	781.8	11891	10	804.5
11825	10	759.1	11859	10	782.4	11892	10	805.2
11826	10	759.8				11893	10	805.8
11827	10	760.5	11860	10	783.1	11894	10	806.5
11828	10	761.2	11861	10	783.8	11895	10	807.2
11829	10	761.9	11862	10	784.5	11896	10	807.9
			11863	10	785.2	11897	10	808.6
11830	10	762.5	11864	10	785.9	11898	10	809.3
11831	10	763.2	11865	10	786.6	11899	10	810.0
11832	10	763.9	11866	10	787.2			
11833	10	764.6	11867	10	787.9	11900	10	810.7

Use check point at 11700 Kc

Frequency: 11700-11800 Kc

Freq.	A	B	Freq.	A	B	Freq.	A	B
11700	10	673.4	11734	10	696.7	11768	10	720.1
11701	10	674.1	11735	10	697.4	11769	10	720.8
11702	10	674.8	11736	10	698.1			
11703	10	675.5	11737	10	698.8	11770	10	721.5
11704	10	676.2	11738	10	699.4	11771	10	722.2
11705	10	676.8	11739	10	700.1	11772	10	722.9
11706	10	677.5				11773	10	723.5
11707	10	678.2	11740	10	700.8	11774	10	724.2
11708	10	678.9	11741	10	701.5	11775	10	724.9
11709	10	679.6	11742	10	702.2	11776	10	725.6
			11743	10	702.9	11777	10	726.3
11710	10	680.3	11744	10	703.6	11778	10	727.0
11711	10	681.0	11745	10	704.2	11779	10	727.7
11712	10	681.6	11746	10	704.9			
11713	10	682.3	11747	10	705.6	11780	10	728.4
11714	10	683.0	11748	10	706.3	11781	10	729.1
11715	10	683.7	11749	10	707.0	11782	10	729.7
11716	10	684.4				11783	10	730.4
11717	10	685.0	11750	10	707.7	11784	10	731.1
11718	10	685.8	11751	10	708.4	11785	10	731.8
11719	10	686.4	11752	10	709.1	11786	10	732.5
			11753	10	709.8	11787	10	733.2
11720	10	687.1	11754	10	710.4	11788	10	733.9
11721	10	687.8	11755	10	711.1	11789	10	734.6
11722	10	688.5	11756	10	711.8			
11723	10	689.2	11757	10	712.5	11790	10	735.3
11724	10	689.9	11758	10	713.2	11791	10	735.9
11725	10	690.5	11759	10	713.9	11792	10	736.6
11726	10	691.2				11793	10	737.3
11727	10	691.9	11760	10	714.6	11794	10	738.0
11728	10	692.6	11761	10	715.3	11795	10	738.7
11729	10	693.3	11762	10	716.0	11796	10	739.4
			11763	10	716.6	11797	10	740.0
11730	10	694.0	11764	10	717.3	11798	10	740.7
11731	10	694.7	11765	10	718.0	11799	10	741.4
11732	10	695.3	11766	10	718.7			
11733	10	696.0	11767	10	719.4	11800	10	742.1

Use check point at 11700 Kc

Frequency: 11900-12000 Kc

Freq.	A	B	Freq.	A	B	Freq.	A	B
11900	10	810.7	11934	10	834.1	11968	10	857.4
11901	10	811.4	11935	10	834.8	11969	10	858.1
11902	10	812.1	11936	10	835.5			
11903	10	812.8	11937	10	836.2	11970	10	858.8
11904	10	813.4	11938	10	836.9	11971	10	859.4
11905	10	814.1	11939	10	837.5	11972	10	860.1
11906	10	814.8				11973	10	860.8
11907	10	815.5	11940	10	838.2	11974	10	861.5
11908	10	816.2	11941	10	838.9	11975	10	862.1
11909	10	816.9	11942	10	839.6	11976	10	862.8
			11943	10	840.3	11977	10	863.5
11910	10	817.6	11944	10	841.0	11978	10	864.2
11911	10	818.3	11945	10	841.6	11979	10	864.8
11912	10	819.0	11946	10	842.3			
11913	10	819.7	11947	10	843.0	11980	10	865.5
11914	10	820.4	11948	10	843.7	11981	10	866.2
11915	10	821.1	11949	10	844.4	11982	10	866.9
11916	10	821.7				11983	10	867.5
11917	10	822.4	11950	10	845.1	11984	10	868.2
11918	10	823.1	11951	10	845.8	11985	10	868.9
11919	10	823.8	11952	10	846.4	11986	10	869.6
			11953	10	847.1	11987	10	870.2
11920	10	824.5	11954	10	847.8	11988	10	870.9
11921	10	825.2	11955	10	848.5	11989	10	871.6
11922	10	825.9	11956	10	849.2			
11923	10	826.6	11957	10	849.9	11990	10	872.3
11924	10	827.3	11958	10	850.5	11991	10	872.9
11925	10	828.0	11959	10	851.2	11992	10	873.6
11926	10	828.6				11993	10	

**TABLE 6-10. CALIBRATION OF HIGH FREQUENCY OSCILLATOR
200KC TO 1810KC**

Frequency: 12000-12100 Kc

Freq.	A	B	Freq.	A	B	Freq.	A	B
12000	11	100.1	12034	11	121.1	12068	11	142.1
12001	11	100.8	12035	11	121.7	12069	11	142.7
12002	11	101.4	12036	11	122.3			
12003	11	102.0	12037	11	123.0	12070	11	143.3
12004	11	102.6	12038	11	123.6	12071	11	143.9
12005	11	103.2	12039	11	124.2	12072	11	144.5
12006	11	103.8				12073	11	145.1
12007	11	104.5	12040	11	124.8	12074	11	145.7
12008	11	105.1	12041	11	125.4	12075	11	146.4
12009	11	105.7	12042	11	126.0	12076	11	147.0
			12043	11	126.7	12077	11	147.6
12010	11	106.3	12044	11	127.3	12078	11	148.2
12011	11	106.9	12045	11	127.9	12079	11	148.8
12012	11	107.5	12046	11	128.5			
12013	11	108.2	12047	11	129.1	12080	11	149.4
12014	11	108.8	12048	11	129.7	12081	11	150.0
12015	11	109.4	12049	11	130.4	12082	11	150.6
12016	11	110.0				12083	11	151.3
12017	11	110.6	12050	11	131.0	12084	11	151.9
12018	11	111.2	12051	11	131.6	12085	11	152.5
12019	11	111.9	12052	11	132.2	12086	11	153.1
			12053	11	132.8	12087	11	153.7
12020	11	112.5	12054	11	133.4	12088	11	154.3
12021	11	113.1	12055	11	134.1	12089	11	154.9
12022	11	113.7	12056	11	134.7			
12023	11	114.3	12057	11	135.3	12090	11	155.6
12024	11	114.9	12058	11	135.9	12091	11	156.2
12025	11	115.6	12059	11	136.5	12092	11	156.8
12026	11	116.2				12093	11	157.4
12027	11	116.8	12060	11	137.1	12094	11	158.0
12028	11	117.4	12061	11	137.8	12095	11	158.6
12029	11	118.0	12062	11	138.4	12096	11	159.2
			12063	11	139.0	12097	11	159.9
12030	11	118.6	12064	11	139.6	12098	11	160.5
12031	11	119.3	12065	11	140.2	12099	11	161.1
12032	11	119.9	12066	11	140.8			
12033	11	120.5	12067	11	141.4	12100	11	161.7

Use check point at 12000 Kc

Frequency: 12200-12300 Kc

Freq.	A	B	Freq.	A	B	Freq.	A	B
12200	11	222.9	12234	11	243.8	12268	11	264.6
12201	11	223.6	12235	11	244.4	12269	11	265.3
12202	11	224.2	12236	11	245.0			
12203	11	224.8	12237	11	245.6	12270	11	265.9
12204	11	225.4	12238	11	246.2	12271	11	266.5
12205	11	226.0	12239	11	246.8	12272	11	267.1
12206	11	226.6				12273	11	267.7
12207	11	227.2	12240	11	247.4	12274	11	268.3
12208	11	227.8	12241	11	248.0	12275	11	268.9
12209	11	228.5	12242	11	248.7	12276	11	269.6
			12243	11	249.3	12277	11	270.2
12210	11	229.1	12244	11	249.9	12278	11	270.8
12211	11	229.7	12245	11	250.5	12279	11	271.4
12212	11	230.3	12246	11	251.1			
12213	11	230.9	12247	11	251.7	12280	11	272.0
12214	11	231.5	12248	11	252.4	12281	11	272.6
12215	11	232.1	12249	11	253.0	12282	11	273.2
12216	11	232.7				12283	11	273.9
12217	11	233.4	12250	11	253.6	12284	11	274.5
12218	11	234.0	12251	11	254.2	12285	11	275.1
12219	11	234.6	12252	11	254.8	12286	11	275.7
			12253	11	255.4	12287	11	276.3
12220	11	235.2	12254	11	256.0	12288	11	276.9
12221	11	235.8	12255	11	256.7	12289	11	277.5
12222	11	236.4	12256	11	257.3			
12223	11	237.0	12257	11	257.9	12290	11	278.2
12224	11	237.6	12258	11	258.5	12291	11	278.8
12225	11	238.3	12259	11	259.1	12292	11	279.4
12226	11	238.9				12293	11	280.0
12227	11	239.5	12260	11	259.7	12294	11	280.6
12228	11	240.1	12261	11	260.3	12295	11	281.2
12229	11	240.7	12262	11	261.0	12296	11	281.8
			12263	11	261.6	12297	11	282.5
12230	11	241.3	12264	11	262.2	12298	11	283.1
12231	11	241.9	12265	11	262.8	12299	11	283.7
12232	11	242.5	12266	11	263.4			
12233	11	243.2	12267	11	264.0	12300	11	284.3

Use check point at 12000 Kc

Frequency: 12100-12200 Kc

Freq.	A	B	Freq.	A	B	Freq.	A	B
12100	11	161.7	12134	11	182.5	12168	11	203.4
12101	11	162.3	12135	11	183.2	12169	11	204.0
12102	11	162.9	12136	11	183.8			
12103	11	163.5	12137	11	184.4	12170	11	204.6
12104	11	164.2	12138	11	185.0	12171	11	205.2
12105	11	164.8	12139	11	185.6	12172	11	205.8
12106	11	165.4				12173	11	206.4
12107	11	166.0	12140	11	186.2	12174	11	207.0
12108	11	166.6	12141	11	186.8	12175	11	207.6
12109	11	167.2	12142	11	187.4	12176	11	208.3
			12143	11	188.1	12177	11	208.9
12110	11	167.8	12144	11	188.7	12178	11	209.5
12111	11	168.5	12145	11	189.3	12179	11	210.1
12112	11	169.1	12146	11	189.9			
12113	11	169.7	12147	11	190.5	12180	11	210.7
12114	11	170.3	12148	11	191.1	12181	11	211.3
12115	11	170.9	12149	11	191.7	12182	11	211.9
12116	11	171.5				12183	11	212.5
12117	11	172.1	12150	11	192.3	12184	11	213.1
12118	11	172.8	12151	11	193.0	12185	11	213.8
12119	11	173.4	12152	11	193.6	12186	11	214.4
			12153	11	194.2	12187	11	215.0
12120	11	174.0	12154	11	194.8	12188	11	215.6
12121	11	174.6	12155	11	195.4	12189	11	216.2
12122	11	175.2	12156	11	196.0			
12123	11	175.8	12157	11	196.6	12190	11	216.8
12124	11	176.4	12158	11	197.2	12191	11	217.4
12125	11	177.0	12159	11	197.8	12192	11	218.0
12126	11	177.7				12193	11	218.7
12127	11	178.3	12160	11	198.5	12194	11	219.3
12128	11	178.9	12161	11	199.1	12195	11	219.9
12129	11	179.5	12162	11	199.7	12196	11	220.5
			12163	11	200.3	12197	11	221.1
12130	11	180.1	12164	11	200.9	12198	11	221.7
12131	11	180.7	12165	11	201.5	12199	11	222.3
12132	11	181.3	12166	11	202.1			
12133	11	181.9	12167	11	202.7	12200	11	222.9

Use check point at 12000 Kc

Frequency: 12300-12400 Kc

Freq.	A	B	Freq.	A	B	Freq.	A	B
12300	11	284.3	12334	11	305.2	12368	11	326.2
12301	11	284.9	12335	11	305.8	12369	11	326.8
12302	11	285.5	12336	11	306.5			
12303	11	286.1	12337	11	307.1	12370	11	327.4
12304	11	286.8	12338	11	307.7	12371	11	328.0
12305	11	287.4	12339	11	308.3	12372	11	328.6
12306	11	288.0				12373	11	329.2
12307	11	288.6	12340	11	308.9	12374	11	329.9
12308	11	289.2	12341	11	309.5	12375	11	330.5
12309	11	289.8	12342	11	310.2	12376	11	331.1
			12343	11	310.8	12377	11	331.7
12310	11	290.5	12344	11	311.4	12378	11	332.3
12311	11	291.1	12345					

**TABLE 6-10. CALIBRATION OF HIGH FREQUENCY OSCILLATOR
2000KC TO 18100KC**

Frequency: 12400-12500 Kc						Frequency: 12600-12700 Kc					
Freq.	A	B	Freq.	A	B	Freq.	A	B	Freq.	A	B
12400	11	345.8	12434	11	366.8	12468	11	387.7	12634	11	490.6
12401	11	346.5	12435	11	367.4	12469	11	388.3	12635	11	491.2
12402	11	347.1	12436	11	368.0				12636	11	491.9
12403	11	347.7	12437	11	368.6	12470	11	388.9	12637	11	492.5
12404	11	348.3	12438	11	369.2	12471	11	389.5	12640	11	493.1
12405	11	348.9	12439	11	369.8	12472	11	390.1	12639	11	493.7
12406	11	349.5				12473	11	390.8	12606	11	473.3
12407	11	350.1	12440	11	370.4	12474	11	391.4	12607	11	473.9
12408	11	350.8	12441	11	371.1	12475	11	392.0	12608	11	474.5
12409	11	351.4	12442	11	371.7	12476	11	392.6	12609	11	475.2
			12443	11	372.3	12477	11	393.2			
12410	11	352.0	12444	11	372.9	12478	11	393.8	12610	11	475.8
12411	11	352.6	12445	11	373.5	12479	11	394.4	12611	11	476.4
12412	11	353.2	12446	11	374.1				12612	11	477.0
12413	11	353.8	12447	11	374.8	12480	11	395.1	12613	11	477.6
12414	11	354.5	12448	11	375.4	12481	11	395.7	12614	11	478.2
12415	11	355.1	12449	11	376.0	12482	11	396.3	12615	11	478.9
12416	11	355.7				12483	11	396.9	12616	11	479.5
12417	11	356.3	12450	11	376.6	12484	11	397.5	12617	11	480.1
12418	11	356.9	12451	11	377.2	12485	11	398.2	12618	11	480.7
12419	11	357.5	12452	11	377.8	12486	11	398.8	12619	11	481.3
			12453	11	378.4	12487	11	399.4			
12420	11	358.1	12454	11	379.1	12488	11	400.0	12620	11	482.0
12421	11	358.8	12455	11	379.7	12489	11	400.7	12621	11	482.6
12422	11	359.4	12456	11	380.3				12622	11	483.2
12423	11	360.0	12457	11	380.9	12490	11	401.3	12623	11	483.8
12424	11	360.6	12458	11	381.5	12491	11	401.9	12624	11	484.4
12425	11	361.2	12459	11	382.1	12492	11	402.5	12625	11	485.1
12426	11	361.8				12493	11	403.1	12626	11	485.7
12427	11	362.4	12460	11	382.8	12494	11	403.8	12627	11	486.3
12428	11	363.1	12461	11	383.4	12495	11	404.4	12628	11	486.9
12429	11	363.7	12462	11	384.0	12496	11	405.0	12629	11	487.5
			12463	11	384.6	12497	11	405.6			
12430	11	364.3	12464	11	385.2	12498	11	406.2	12630	11	488.2
12431	11	364.9	12465	11	385.8	12499	11	406.9	12631	11	488.8
12432	11	365.5	12466	11	386.4				12632	11	489.4
12433	11	366.1	12467	11	387.1	12500	11	407.5	12633	11	490.0

Frequency: 12500-12600 Kc						Frequency: 12700-12800 Kc					
Freq.	A	B	Freq.	A	B	Freq.	A	B	Freq.	A	B
12500	11	407.5	12534	11	428.6	12568	11	449.7	12700	11	531.7
12501	11	408.1	12535	11	429.2	12569	11	450.3	12701	11	532.3
12502	11	408.7	12536	11	429.9				12702	11	532.9
12503	11	409.4	12537	11	430.5	12570	11	451.0	12703	11	533.5
12504	11	410.0	12538	11	431.1	12571	11	451.6	12704	11	534.1
12505	11	410.6	12539	11	431.7	12572	11	452.2	12705	11	534.8
12506	11	411.2				12573	11	452.8	12706	11	535.4
12507	11	411.8	12540	11	432.3	12574	11	453.4	12707	11	536.0
12508	11	412.5	12541	11	433.0	12575	11	454.1	12708	11	536.6
12509	11	413.1	12542	11	433.6	12576	11	454.7	12709	11	537.3
			12543	11	434.2	12577	11	455.3			
12510	11	413.7	12544	11	434.8	12578	11	455.9	12710	11	537.9
12511	11	414.3	12545	11	435.4	12579	11	456.5	12711	11	538.5
12512	11	414.9	12546	11	436.1				12712	11	539.1
12513	11	415.6	12547	11	436.7	12580	11	457.2	12713	11	539.8
12514	11	416.2	12548	11	437.3	12581	11	457.8	12714	11	540.4
12515	11	416.8	12549	11	437.9	12582	11	458.4	12715	11	541.0
12516	11	417.4				12583	11	459.0	12716	11	541.6
12517	11	418.0	12550	11	438.5	12584	11	459.6	12717	11	542.3
12518	11	418.7	12551	11	439.2	12585	11	460.3	12718	11	542.9
12519	11	419.3	12552	11	439.8	12586	11	460.9	12719	11	543.5
			12553	11	440.4	12587	11	461.5			
12520	11	419.9	12554	11	441.0	12588	11	462.1	12720	11	544.1
12521	11	420.5	12555	11	441.7	12589	11	462.8	12721	11	544.7
12522	11	421.2	12556	11	442.3				12722	11	545.4
12523	11	421.8	12557	11	442.9	12590	11	463.4	12723	11	546.0
12524	11	422.4	12558	11	443.5	12591	11	464.0	12724	11	546.6
12525	11	423.0	12559	11	444.1	12592	11	464.6	12725	11	547.2
12526	11	423.6				12593	11	465.2	12726	11	547.9
12527	11	424.3	12560	11	444.8	12594	11	465.9	12727	11	548.5
12528	11	424.9	12561	11	445.4	12595	11	466.5	12728	11	549.1
12529	11	425.5	12562	11	446.0	12596	11	467.1	12729	11	549.7
			12563	11	446.6	12597	11	467.7			
12530	11	426.1	12564	11	447.2	12598	11	468.3	12730	11	550.3
12531	11	426.7	12565	11	447.9	12599	11	469.0	12731	11	551.0
12532	11	427.4	12566	11	448.5				12732	11	551.6
12533	11	428.0	12567	11	449.1	12600	11	469.6	12733	11	552.2

**TABLE 6-10. CALIBRATION OF HIGH FREQUENCY OSCILLATOR
2000KC TO 18100KC**

Frequency: 12800—12900 Kc

Freq.	A	B	Freq.	A	B	Freq.	A	B
12800	11	593.9	12834	11	615.1	12868	11	636.3
12801	11	594.5	12835	11	615.7	12869	11	636.9
12802	11	595.1	12836	11	616.3			
12803	11	595.8	12837	11	617.0	12870	11	637.5
12804	11	596.4	12838	11	617.6	12871	11	638.2
12805	11	597.0	12839	11	618.2	12872	11	638.8
12806	11	597.6				12873	11	639.4
12807	11	598.3	12840	11	618.8	12874	11	640.0
12808	11	598.9	12841	11	619.5	12875	11	640.7
12809	11	599.5	12842	11	620.1	12876	11	641.3
			12843	11	620.7	12877	11	641.9
12810	11	600.1	12844	11	621.3	12878	11	642.5
12811	11	600.8	12845	11	622.0	12879	11	643.2
12812	11	601.4	12846	11	622.6			
12813	11	602.0	12847	11	623.2	12880	11	643.8
12814	11	602.6	12848	11	623.8	12881	11	644.4
12815	11	603.2	12849	11	624.5	12882	11	645.0
12816	11	603.9				12883	11	645.6
12817	11	604.5	12850	11	625.1	12884	11	646.3
12818	11	605.1	12851	11	625.7	12885	11	646.9
12819	11	605.7	12852	11	626.3	12886	11	647.5
			12853	11	626.9	12887	11	648.1
12820	11	606.4	12854	11	627.6	12888	11	648.8
12821	11	607.0	12855	11	628.2	12889	11	649.4
12822	11	607.6	12856	11	628.8			
12823	11	608.2	12857	11	629.4	12890	11	650.0
12824	11	608.9	12858	11	630.1	12891	11	650.6
12825	11	609.5	12859	11	630.7	12892	11	651.3
12826	11	610.1				12893	11	651.9
12827	11	610.7	12860	11	631.3	12894	11	652.5
12828	11	611.4	12861	11	631.9	12895	11	653.1
12829	11	612.0	12862	11	632.6	12896	11	653.7
			12863	11	633.2	12897	11	654.4
12830	11	612.6	12864	11	633.8	12898	11	655.0
12831	11	613.2	12865	11	634.4	12899	11	655.6
12832	11	613.9	12866	11	635.0			
12833	11	614.5	12867	11	635.7	12900	11	656.2

Use check point at 12600 Kc

Frequency: 13000—13100 Kc

Freq.	A	B	Freq.	A	B	Freq.	A	B
13000	11	718.5	13034	11	739.7	13068	11	761.0
13001	11	719.1	13035	11	740.4	13069	11	761.6
13002	11	719.8	13036	11	741.0			
13003	11	720.4	13037	11	741.6	13070	11	762.2
13004	11	721.0	13038	11	742.2	13071	11	762.8
13005	11	721.6	13039	11	742.8	13072	11	763.5
13006	11	722.3				13073	11	764.1
13007	11	722.9	13040	11	743.5	13074	11	764.7
13008	11	723.5	13041	11	744.1	13075	11	765.3
13009	11	724.1	13042	11	744.7	13076	11	766.0
			13043	11	745.3	13077	11	766.6
13010	11	724.7	13044	11	746.0	13078	11	767.2
13011	11	725.4	13045	11	746.6	13079	11	767.8
13012	11	726.0	13046	11	747.2			
13013	11	726.6	13047	11	747.8	13080	11	768.5
13014	11	727.2	13048	11	748.5	13081	11	769.1
13015	11	727.9	13049	11	749.1	13082	11	769.7
13016	11	728.5				13083	11	770.3
13017	11	729.1	13050	11	749.7	13084	11	770.9
13018	11	729.7	13051	11	750.3	13085	11	771.6
13019	11	730.4	13052	11	751.0	13086	11	772.2
			13053	11	751.6	13087	11	772.8
13020	11	731.0	13054	11	752.2	13088	11	773.4
13021	11	731.6	13055	11	752.8	13089	11	774.0
13022	11	732.2	13056	11	753.5			
13023	11	732.9	13057	11	754.1	13090	11	774.7
13024	11	733.5	13058	11	754.7	13091	11	775.3
13025	11	734.1	13059	11	755.3	13092	11	775.9
13026	11	734.7				13093	11	776.5
13027	11	735.4	13060	11	756.0	13094	11	777.1
13028	11	736.0	13061	11	756.6	13095	11	777.8
13029	11	736.6	13062	11	757.2	13096	11	778.4
			13063	11	757.8	13097	11	779.0
13030	11	737.2	13064	11	758.5	13098	11	779.6
13031	11	737.9	13065	11	759.1	13099	11	780.2
13032	11	738.5	13066	11	759.7			
13033	11	739.1	13067	11	760.3	13100	11	780.9

Use check point at 13200 Kc

Frequency: 12900—13000 Kc

Freq.	A	B	Freq.	A	B	Freq.	A	B
12900	11	656.2	12934	11	677.4	12968	11	698.6
12901	11	656.9	12935	11	678.0	12969	11	699.2
12902	11	657.5	12936	11	678.6			
12903	11	658.1	12937	11	679.3	12970	11	699.8
12904	11	658.7	12938	11	679.9	12971	11	700.4
12905	11	659.4	12939	11	680.5	12972	11	701.1
12906	11	660.0				12973	11	701.7
12907	11	660.6	12940	11	681.1	12974	11	702.3
12908	11	661.2	12941	11	681.8	12975	11	702.9
12909	11	661.8	12942	11	682.4	12976	11	703.6
			12943	11	683.0	12977	11	704.2
12910	11	662.5	12944	11	683.6	12978	11	704.8
12911	11	663.1	12945	11	684.2	12979	11	705.4
12912	11	663.7	12946	11	684.9			
12913	11	664.3	12947	11	685.5	12980	11	706.0
12914	11	665.0	12948	11	686.1	12981	11	706.7
12915	11	665.6	12949	11	686.7	12982	11	707.3
12916	11	666.2				12983	11	707.9
12917	11	666.8	12950	11	687.4	12984	11	708.5
12918	11	667.4	12951	11	688.0	12985	11	709.2
12919	11	668.1	12952	11	688.6	12986	11	709.8
			12953	11	689.2	12987	11	710.4
12920	11	668.7	12954	11	689.8	12988	11	711.0
12921	11	669.3	12955	11	690.4	12989	11	711.7
12922	11	669.9	12956	11	691.1			
12923	11	670.6	12957	11	691.7	12990	11	712.3
12924	11	671.2	12958	11	692.3	12991	11	712.9
12925	11	671.8	12959	11	693.0	12992	11	713.5
12926	11	672.4				12993	11	714.2
12927	11	673.0	12960	11	693.6	12994	11	714.8
12928	11	673.7	12961	11	694.2	12995	11	715.4
12929	11	674.3	12962	11	694.8	12996	11	716.0
			12963	11	695.5	12997	11	716.6
12930	11	674.9	12964	11	696.1	12998	11	717.3
12931	11	675.5	12965	11	696.7	12999	11	717.9
12932	11	676.2	12966	11	697.3			
12933	11	676.8	12967	11	697.9	13000	11	718.5

Use check point at 13200 Kc

Frequency: 13100—13200 Kc

Freq.	A	B	Freq.	A	B	Freq.	A	B
13100	11	780.9	13134	11	802.0	13168	11	823.1
13101	11	781.5	13135	11	802.6	13169	11	823.7
13102	11	782.1	13136	11	803.2			
13103	11	782.7	13137	11	803.8	13170	11	824.3
13104	11	783.3	13138	11	804.4	13171	11	825.0
13105	11	784.0	13139	11	805.1	13172	11	825.6
13106	11	784.6				13173	11	826.2
13107	11	785.2	13140	11	805.7	13174	11	826.8
13108	11	785.8	13141	11	806.3	13175	11	827.5
13109	11	786.4	13142	11	806.9	13176	11	828.1
			13143	11	807.5	13177	11	828.7
13110	11	787.1	13144	11	808.2	13178	11	829.3
13111	11	787.7	13145	11	808.8	13179	11	829.9
13112	11	788.3	13146	11	809.4			
13113	11	788.9	13147	11	810.0	13180	11	830.6
13114	11	789.6	13148	11	810.7	13181	11	831.2
13115	11	790.2	13149	11	811.3	13182	11	831.8
13116	11	790.8				13183	11	832.4
13117	11	791.4	13150	11	811.9	13184	11	833.0
13118	11	792.0	13151	11	812.5	13185	11	833.7
13119	11	792.7	13152	11	813.1	13186	11	834.3
			13153	11	813.8	13187	11	834.9
13120	11	793.3	13154	11	814.4	13188	11	835.5
13121	11	793.9	13155	11	815.0	13189	11	836.2
13122	11	794.5	13156	11	815.6			
13123	11	795.1	13157	11	816.3	13190	11	836.8
13124	11	795.8	13158	11	816.9	13191	11	837.4
13125	11	796.4	13159	11	817.5	13192	11	838.0
13126	11	797.0				13193	11	838.6
13127								

**TABLE 6-10. CALIBRATION OF HIGH FREQUENCY OSCILLATOR
2000KC TO 18100KC**

Frequency: 13200—13300 Kc

Freq.	A	B	Freq.	A	B	Freq.	A	B
13200	11	843.0	13234	11	864.0	13268	11	885.1
13201	11	843.6	13235	11	864.7	13269	11	885.7
13202	11	844.2	13236	11	865.3			
13203	11	844.9	13237	11	865.9	13270	11	886.3
13204	11	845.5	13238	11	866.5	13271	11	886.9
13205	11	846.1	13239	11	867.1	13272	11	887.5
13206	11	846.7				13273	11	888.2
13207	11	847.3	13240	11	867.7	13274	11	888.8
13208	11	848.0	13241	11	868.4	13275	11	889.4
13209	11	848.6	13242	11	869.0	13276	11	890.0
			13243	11	869.6	13277	11	890.6
13210	11	849.2	13244	11	870.2	13278	11	891.3
13211	11	849.8	13245	11	870.8	13279	11	891.9
13212	11	850.4	13246	11	871.5			
13213	11	851.0	13247	11	872.1	13280	11	892.5
13214	11	851.7	13248	11	872.7	13281	11	893.1
13215	11	852.3	13249	11	873.3	13282	11	893.7
13216	11	852.9				13283	11	894.3
13217	11	853.5	13250	11	873.9	13284	11	895.0
13218	11	854.1	13251	11	874.6	13285	11	895.6
13219	11	854.8	13252	11	875.2	13286	11	896.2
			13253	11	875.8	13287	11	896.8
13220	11	855.4	13254	11	876.4	13288	11	897.4
13221	11	856.0	13255	11	877.0	13289	11	898.1
13222	11	856.6	13256	11	877.6			
13223	11	857.2	13257	11	878.3	13290	11	898.7
13224	11	857.8	13258	11	878.9	13291	11	899.3
13225	11	858.5	13259	11	879.5	13292	11	899.9
13226	11	859.1				13293	11	900.5
13227	11	859.7	13260	11	880.1	13294	11	901.2
13228	11	860.3	13261	11	880.7	13295	11	901.8
13229	11	860.9	13262	11	881.4	13296	11	902.4
			13263	11	882.0	13297	11	903.0
13230	11	861.6	13264	11	882.6	13298	11	903.6
13231	11	862.2	13265	11	883.2	13299	11	904.2
13232	11	862.8	13266	11	883.8			
13233	11	863.4	13267	11	884.5	13300	11	904.9

Use check point at 13200 Kc

Frequency: 13400—13500 Kc

Freq.	A	B	Freq.	A	B	Freq.	A	B
13400	11	966.6	13434	11	987.6	13468	11	1008.5
13401	11	967.3	13435	11	988.2	13469	11	1009.1
13402	11	967.9	13436	11	988.8			
13403	11	968.5	13437	11	989.4	13470	11	1009.8
13404	11	969.1	13438	11	990.0	13471	11	1010.4
13405	11	969.7	13439	11	990.6	13472	11	1011.0
13406	11	970.3				13473	11	1011.6
13407	11	970.9	13440	11	991.2	13474	11	1012.2
13408	11	971.6	13441	11	991.9	13475	11	1012.8
13409	11	972.2	13442	11	992.5	13476	11	1013.5
			13443	11	993.1	13477	11	1014.1
13410	11	972.8	13444	11	993.7	13478	11	1014.7
13411	11	973.4	13445	11	994.3	13479	11	1015.3
13412	11	974.0	13446	11	994.9			
13413	11	974.6	13447	11	995.6	13480	11	1015.9
13414	11	975.3	13448	11	996.2	13481	11	1016.5
13415	11	975.9	13449	11	996.8	13482	11	1017.2
13416	11	976.5				13483	11	1017.8
13417	11	977.1	13450	11	997.4	13484	11	1018.4
13418	11	977.7	13451	11	998.0	13485	11	1019.0
13419	11	978.3	13452	11	998.6	13486	11	1019.6
			13453	11	999.3	13487	11	1020.2
13420	11	978.9	13454	11	999.9	13488	11	1020.9
13421	11	979.6	13455	11	1000.5	13489	11	1021.5
13422	11	980.2	13456	11	1001.1			
13423	11	980.8	13457	11	1001.7	13490	11	1022.1
13424	11	981.4	13458	11	1002.3	13491	11	1022.7
13425	11	982.0	13459	11	1003.0	13492	11	1023.3
13426	11	982.6				13493	11	1023.9
13427	11	983.2	13460	11	1003.6	13494	11	1024.6
13428	11	983.9	13461	11	1004.2	13495	11	1025.2
13429	11	984.5	13462	11	1004.8	13496	11	1025.8
			13463	11	1005.4	13497	11	1026.4
13430	11	985.1	13464	11	1006.0	13498	11	1027.0
13431	11	985.7	13465	11	1006.7	13499	11	1027.6
13432	11	986.3	13466	11	1007.3			
13433	11	986.9	13467	11	1007.9	13500	11	1028.3

Use check point at 13200 Kc

Frequency: 13300—13400 Kc

Freq.	A	B	Freq.	A	B	Freq.	A	B
13300	11	904.9	13334	11	925.9	13368	11	946.9
13301	11	905.5	13335	11	926.5	13369	11	947.5
13302	11	906.1	13336	11	927.1			
13303	11	906.7	13337	11	927.8	13370	11	948.2
13304	11	907.3	13338	11	928.4	13371	11	948.8
13305	11	908.0	13339	11	929.0	13372	11	949.4
13306	11	908.6				13373	11	950.0
13307	11	909.2	13340	11	929.6	13374	11	950.6
13308	11	909.8	13341	11	930.2	13375	11	951.2
13309	11	910.4	13342	11	930.8	13376	11	951.9
			13343	11	931.5	13377	11	952.5
13310	11	911.1	13344	11	932.1	13378	11	953.1
13311	11	911.7	13345	11	932.7	13379	11	953.7
13312	11	912.3	13346	11	933.3			
13313	11	912.9	13347	11	933.9	13380	11	954.3
13314	11	913.5	13348	11	934.6	13381	11	955.0
13315	11	914.1	13349	11	935.2	13382	11	955.6
13316	11	914.8				13383	11	956.2
13317	11	915.4	13350	11	935.8	13384	11	956.8
13318	11	916.0	13351	11	936.4	13385	11	957.4
13319	11	916.6	13352	11	937.0	13386	11	958.0
			13353	11	937.6	13387	11	958.6
13320	11	917.2	13354	11	938.3	13388	11	959.3
13321	11	917.9	13355	11	938.9	13389	11	959.9
13322	11	918.5	13356	11	939.5			
13323	11	919.1	13357	11	940.1	13390	11	960.5
13324	11	919.7	13358	11	940.7	13391	11	961.1
13325	11	920.3	13359	11	941.4	13392	11	961.7
13326	11	921.0				13393	11	962.3
13327	11	921.6	13360	11	942.0	13394	11	963.0
13328	11	922.2	13361	11	942.6	13395	11	963.6
13329	11	922.8	13362	11	943.2	13396	11	964.2
			13363	11	943.8	13397	11	964.8
13330	11	923.4	13364	11	944.4	13398	11	965.4
13331	11	924.0	13365	11	945.1	13399	11	966.0
13332	11	924.7	13366	11	945.7			
13333	11	925.3	13367	11	946.3	13400	11	966.6

Use check point at 13200 Kc

Frequency: 13500—13600 Kc

Freq.	A	B	Freq.	A	B	Freq.	A	B
13500	11	1028.3	13534	11	1049.2	13568	11	1070.1
13501	11	1028.9	13535	11	1049.8	13569	11	1070.8
13502	11	1029.5	13536	11	1050.5			
13503	11	1030.1	13537	11	1051.1	13570	11	1071.4
13504	11	1030.7	13538	11	1051.7	13571	11	1072.0
13505	11	1031.3	13539	11	1052.3	13572	11	1072.6
13506	11	1032.0				13573	11	1073.2
13507	11	1032.6	13540	11	1052.9	13574	11	1073.8
13508	11	1033.2	13541	11	1053.5	13575	11	1074.4
13509	11	1033.8	13542	11	1054.2	13576	11	1075.0
			13543	11	1054.8	13577	11	1075.6
13510	11	1034.4	13544	11	1055.4	13578	11	1076.3
13511	11	1035.0	13545	11	1056.0	13579	11	1076.9
13512	11	1035.7	13546	11	1056.6			
13513	11	1036.3	13547	11	1057.2	13580	11	1077.5
13514	11	1036.9	13548	11	1057.9	13581	11	1078.1
13515	11	1037.5	13549	11	1058.5	13582	11	1078.7
13516	11	1038.1				13583	11	1079.3
13517	11	1038.7	13550	11	1059.1	13584	11	1079.9
13518	11	1039.4	13551	11	1059.7	13585	11	1080.5
13519	11	1040.0	13552	11	1060.3	13586	11	1081.1
			13553	11	1060.9	13587	11	1081.8
13520	11	1040.6	13554	11	1061.6	13588	11	1082.4
13521	11	1041.2	13555	11	1062.2	13589	11	1083.0
13522	11	1041.8	13556	11	1062.8			
13523	11	1042.4	13557	11	1063.4	13590	11	1083.6
13524	11	1043.1	13558	11	1064.0	13591	11	1084.2
13525	11	1043.7	13559	11				

**TABLE 6-10. CALIBRATION OF HIGH FREQUENCY OSCILLATOR
2000KC TO 18100KC**

Frequency: 13600-13700 Kc

Freq.	A	B	Freq.	A	B	Freq.	A	B
13600	11	1089.7	13634	11	1110.5	13668	11	1131.3
13601	11	1090.3	13635	11	1111.1	13669	11	1131.9
13602	11	1090.9	13636	11	1111.7			
13603	11	1091.5	13637	11	1112.3	13670	11	1132.5
13604	11	1092.1	13638	11	1112.9	13671	11	1133.1
13605	11	1092.7	13639	11	1113.5	13672	11	1133.7
13606	11	1093.4				13673	11	1134.3
13607	11	1094.0	13640	11	1114.1	13674	11	1134.9
13608	11	1094.6	13641	11	1114.8	13675	11	1135.6
13609	11	1095.2	13642	11	1115.4	13676	11	1136.2
			13643	11	1116.0	13677	11	1136.8
13610	11	1095.8	13644	11	1116.6	13678	11	1137.4
13611	11	1096.4	13645	11	1117.2	13679	11	1138.0
13612	11	1097.0	13646	11	1117.8			
13613	11	1097.6	13647	11	1118.4	13680	11	1138.6
13614	11	1098.2	13648	11	1119.0	13681	11	1139.2
13615	11	1098.9	13649	11	1119.6	13682	11	1139.8
13616	11	1099.5				13683	11	1140.4
13617	11	1100.1	13650	11	1120.3	13684	11	1141.1
13618	11	1100.7	13651	11	1120.9	13685	11	1141.7
13619	11	1101.3	13652	11	1121.5	13686	11	1142.3
			13653	11	1122.1	13687	11	1142.9
13620	11	1101.9	13654	11	1122.7	13688	11	1143.5
13621	11	1102.5	13655	11	1123.3	13689	11	1144.1
13622	11	1103.1	13656	11	1123.9			
13623	11	1103.7	13657	11	1124.5	13690	11	1144.7
13624	11	1104.4	13658	11	1125.2	13691	11	1145.3
13625	11	1105.0	13659	11	1125.8	13692	11	1145.9
13626	11	1105.6				13693	11	1146.5
13627	11	1106.2	13660	11	1126.4	13694	11	1147.2
13628	11	1106.8	13661	11	1127.0	13695	11	1147.8
13629	11	1107.4	13662	11	1127.6	13696	11	1148.4
			13663	11	1128.2	13697	11	1149.0
13630	11	1108.0	13664	11	1128.8	13698	11	1149.6
13631	11	1108.6	13665	11	1129.4	13699	11	1150.2
13632	11	1109.2	13666	11	1130.0			
13633	11	1109.9	13667	11	1130.7	13700	11	1150.8

Use check point at 13800 Kc

Frequency: 13800-13900 Kc

Freq.	A	B	Freq.	A	B	Freq.	A	B
13800	11	1211.8	13834	11	1232.5	13868	11	1253.2
13801	11	1212.4	13835	11	1233.1	13869	11	1253.8
13802	11	1213.0	13836	11	1233.7			
13803	11	1213.6	13837	11	1234.3	13870	11	1254.4
13804	11	1214.2	13838	11	1234.9	13871	11	1255.0
13805	11	1214.8	13839	11	1235.5	13872	11	1255.6
13806	11	1215.4				13873	11	1256.2
13807	11	1216.0	13840	11	1236.1	13874	11	1256.8
13808	11	1216.6	13841	11	1236.7	13875	11	1257.4
13809	11	1217.3	13842	11	1237.3	13876	11	1258.0
			13843	11	1238.0	13877	11	1258.7
13810	11	1217.9	13844	11	1238.6	13878	11	1259.3
13811	11	1218.5	13845	11	1239.2	13879	11	1259.9
13812	11	1219.1	13846	11	1239.8			
13813	11	1219.7	13847	11	1240.4	13880	11	1260.5
13814	11	1220.3	13848	11	1241.0	13881	11	1261.1
13815	11	1220.9	13849	11	1241.6	13882	11	1261.7
13816	11	1221.5				13883	11	1262.3
13817	11	1222.1	13850	11	1242.2	13884	11	1262.9
13818	11	1222.7	13851	11	1242.8	13885	11	1263.5
13819	11	1223.3	13852	11	1243.4	13886	11	1264.1
			13853	11	1244.0	13887	11	1264.7
13820	11	1224.0	13854	11	1244.6	13888	11	1265.4
13821	11	1224.6	13855	11	1245.3	13889	11	1266.0
13822	11	1225.2	13856	11	1245.9			
13823	11	1225.8	13857	11	1246.5	13890	11	1266.6
13824	11	1226.4	13858	11	1247.1	13891	11	1267.2
13825	11	1227.0	13859	11	1247.7	13892	11	1267.8
13826	11	1227.6				13893	11	1268.4
13827	11	1228.2	13860	11	1248.3	13894	11	1269.0
13828	11	1228.8	13861	11	1248.9	13895	11	1269.6
13829	11	1229.4	13862	11	1249.5	13896	11	1270.2
			13863	11	1250.1	13897	11	1270.8
13830	11	1230.0	13864	11	1250.7	13898	11	1271.4
13831	11	1230.6	13865	11	1251.3	13899	11	1272.1
13832	11	1231.3	13866	11	1252.0			
13833	11	1231.9	13867	11	1252.6	13900	11	1272.7

Use check point at 13800 Kc

Frequency: 13700-13800 Kc

Freq.	A	B	Freq.	A	B	Freq.	A	B
13700	11	1150.8	13734	11	1171.6	13768	11	1192.3
13701	11	1151.4	13735	11	1172.2	13769	11	1192.9
13702	11	1152.0	13736	11	1172.8			
13703	11	1152.6	13737	11	1173.4	13770	11	1193.5
13704	11	1153.3	13738	11	1174.0	13771	11	1194.1
13705	11	1153.9	13739	11	1174.6	13772	11	1194.7
13706	11	1154.5				13773	11	1195.3
13707	11	1155.1	13740	11	1175.2	13774	11	1195.9
13708	11	1155.7	13741	11	1175.8	13775	11	1196.6
13709	11	1156.3	13742	11	1176.4	13776	11	1197.2
			13743	11	1177.1	13777	11	1197.8
13710	11	1156.9	13744	11	1177.7	13778	11	1198.4
13711	11	1157.5	13745	11	1178.3	13779	11	1199.0
13712	11	1158.1	13746	11	1178.9			
13713	11	1158.8	13747	11	1179.5	13780	11	1199.6
13714	11	1159.4	13748	11	1180.1	13781	11	1200.2
13715	11	1160.0	13749	11	1180.7	13782	11	1200.8
13716	11	1160.6				13783	11	1201.4
13717	11	1161.2	13750	11	1181.3	13784	11	1202.0
13718	11	1161.8	13751	11	1181.9	13785	11	1202.6
13719	11	1162.4	13752	11	1182.5	13786	11	1203.3
			13753	11	1183.1	13787	11	1203.9
13720	11	1163.0	13754	11	1183.8	13788	11	1204.5
13721	11	1163.6	13755	11	1184.4	13789	11	1205.1
13722	11	1164.2	13756	11	1185.0			
13723	11	1164.9	13757	11	1185.6	13790	11	1205.7
13724	11	1165.5	13758	11	1186.2	13791	11	1206.3
13725	11	1166.1	13759	11	1186.8	13792	11	1206.9
13726	11	1166.7				13793	11	1207.5
13727	11	1167.3	13760	11	1187.4	13794	11	1208.1
13728	11	1167.9	13761	11	1188.0	13795	11	1208.7
13729	11	1168.5	13762	11	1188.6	13796	11	1209.3
			13763	11	1189.2	13797	11	1210.0
13730	11	1169.1	13764	11	1189.9	13798	11	1210.6
13731	11	1169.7	13765	11	1190.5	13799	11	1211.2
13732	11	1170.3	13766	11	1191.1			
13733	11	1171.0	13767	11	1191.7	13800	11	1211.8

Use check point at 13800 Kc

Frequency: 13900-14000 Kc

Freq.	A	B	Freq.	A	B	Freq.	A	B
13900	11	1272.7	13934	11	1293.4	13968	11	1314.2
13901	11	1273.3	13935	11	1294.0	13969	11	1314.8
13902	11	1273.9	13936	11	1294.6			
13903	11	1274.5	13937	11	1295.2	13970	11	1315.4
13904	11	1275.1	13938	11	1295.8	13971	11	1316.0
13905	11	1275.7	13939	11	1296.5	13972	11	1316.6
13906	11	1276.3				13973	11	1317.2
13907	11	1276.9	13940	11	1297.1	13974	11	1317.9
13908	11	1277.5	13941	11	1297.7	13975	11	1318.5
13909	11	1278.1	13942	11	1298.3	13976	11	1319.1
			13943	11	1298.9	13977	11	1319.7
13910	11	1278.8	13944	11	1299.5	13978	11	1320.3
13911	11	1279.4	13945	11	1300.1	13979	11	1320.9
13912	11	1280.0	13946	11	1300.7			
13913	11	1280.6	13947	11	1301.3	13980	11	1321.5
13914	11	1281.2	13948	11	1302.0	13981	11	1322.1
13915	11	1281.8	13949	11	1302.6	13982	11	1322.7
13916	11	1282.4				13983	11	1323.4
13917	11	1283.0	13950	11	1303.2	13984	11	1324.0
13918	11	1283.6	13951	11	1303.8	13985	11	1324.6
13919	11	1284.2	13952	11	1304.4	13986	11	1325.2
			13953	11	1305.0	13987	11	1325.8
13920	11	1284.8	13954	11	1305.6	13988	11	1326.4
13921	11	1285.5	13955	11	1306.2	13989	11	1327.0
13922	11							

**TABLE 6-10. CALIBRATION OF HIGH FREQUENCY OSCILLATOR
2000KC TO 18100KC**

Frequency: 14000—14100 Kc

Freq.	A	B	Freq.	A	B	Freq.	A	B
14000	11	1333.7	14034	11	1354.5	14068	11	1375.2
14001	11	1334.3	14035	11	1355.1	14069	11	1375.8
14002	11	1334.9	14036	11	1355.7			
14003	11	1335.6	14037	11	1356.3	14070	11	1376.4
14004	11	1336.2	14038	11	1356.9	14071	11	1377.0
14005	11	1336.8	14039	11	1357.5	14072	11	1377.6
14006	11	1337.4				14073	11	1378.2
14007	11	1338.0	14040	11	1368.1	14074	11	1378.8
14008	11	1338.6	14041	11	1358.7	14075	11	1379.4
14009	11	1339.2	14042	11	1359.3	14076	11	1380.0
			14043	11	1359.9	14077	11	1380.6
14010	11	1339.8	14044	11	1360.6	14078	11	1381.2
14011	11	1340.4	14045	11	1361.2	14079	11	1381.9
14012	11	1341.0	14046	11	1361.8			
14013	11	1341.7	14047	11	1362.4	14080	11	1382.5
14014	11	1342.3	14048	11	1363.0	14081	11	1383.1
14015	11	1342.9	14049	11	1363.6	14082	11	1383.7
14016	11	1343.5				14083	11	1384.3
14017	11	1344.1	14050	11	1364.2	14084	11	1384.9
14018	11	1344.7	14051	11	1364.8	14085	11	1385.5
14019	11	1345.3	14052	11	1365.4	14086	11	1386.1
			14053	11	1366.0	14087	11	1386.7
14020	11	1345.9	14054	11	1366.6	14088	11	1387.3
14021	11	1346.5	14055	11	1367.3	14089	11	1387.9
14022	11	1347.1	14056	11	1367.9			
14023	11	1347.8	14057	11	1368.5	14090	11	1388.6
14024	11	1348.4	14058	11	1369.1	14091	11	1389.2
14025	11	1349.0	14059	11	1369.7	14092	11	1389.8
14026	11	1349.6				14093	11	1390.4
14027	11	1350.2	14060	11	1370.3	14094	11	1391.0
14028	11	1350.8	14061	11	1370.9	14095	11	1391.6
14029	11	1351.4	14062	11	1371.5	14096	11	1392.2
			14063	11	1372.1	14097	11	1392.8
14030	11	1352.0	14064	11	1372.7	14098	11	1393.4
14031	11	1352.6	14065	11	1373.3	14099	11	1394.0
14032	11	1353.2	14066	11	1373.9			
14033	11	1353.9	14067	11	1374.6	14100	11	1394.6

Use check point at 13800 Kc

Frequency: 14200—14300 Kc

Freq.	A	B	Freq.	A	B	Freq.	A	B
14200	11	1455.7	14234	11	1476.5	14268	11	1497.4
14201	11	1456.3	14235	11	1477.1	14269	11	1498.1
14202	11	1456.9	14236	11	1477.7			
14203	11	1457.5	14237	11	1478.3	14270	11	1498.7
14204	11	1458.1	14238	11	1479.0	14271	11	1499.3
14205	11	1458.7	14239	11	1479.6	14272	11	1499.9
14206	11	1459.3				14273	11	1500.5
14207	11	1460.0	14240	11	1480.2	14274	11	1501.1
14208	11	1460.6	14241	11	1480.8	14275	11	1501.8
14209	11	1461.2	14242	11	1481.4	14276	11	1502.4
			14243	11	1482.0	14277	11	1503.0
14210	11	1461.8	14244	11	1482.7	14278	11	1503.6
14211	11	1462.4	14245	11	1483.3	14279	11	1504.2
14212	11	1463.0	14246	11	1483.9			
14213	11	1463.6	14247	11	1484.5	14280	11	1504.8
14214	11	1464.2	14248	11	1485.1	14281	11	1505.5
14215	11	1464.8	14249	11	1485.7	14282	11	1506.1
14216	11	1465.4				14283	11	1506.7
14217	11	1466.0	14250	11	1486.4	14284	11	1507.3
14218	11	1466.6	14251	11	1487.0	14285	11	1507.9
14219	11	1467.3	14252	11	1487.6	14286	11	1508.5
			14253	11	1488.2	14287	11	1509.1
14220	11	1467.9	14254	11	1488.8	14288	11	1509.8
14221	11	1468.5	14255	11	1489.4	14289	11	1510.4
14222	11	1469.1	14256	11	1490.0			
14223	11	1469.7	14257	11	1490.7	14290	11	1511.0
14224	11	1470.3	14258	11	1491.3	14291	11	1511.6
14225	11	1470.9	14259	11	1491.9	14292	11	1512.2
14226	11	1471.6				14293	11	1512.8
14227	11	1472.2	14260	11	1492.5	14294	11	1513.4
14228	11	1472.8	14261	11	1493.1	14295	11	1514.1
14229	11	1473.4	14262	11	1493.7	14296	11	1514.7
			14263	11	1494.4	14297	11	1515.3
14230	11	1474.0	14264	11	1495.0	14298	11	1515.9
14231	11	1474.6	14265	11	1495.6	14299	11	1516.5
14232	11	1475.3	14266	11	1496.2			
14233	11	1475.9	14267	11	1496.8	14300	11	1517.1

Use check point at 14400 Kc

Frequency: 14100—14200 Kc

Freq.	A	B	Freq.	A	B	Freq.	A	B
14100	11	1394.6	14134	11	1415.4	14168	11	1436.2
14101	11	1395.3	14135	11	1416.1	14169	11	1436.8
14102	11	1395.9	14136	11	1416.7			
14103	11	1396.5	14137	11	1417.3	14170	11	1437.4
14104	11	1397.1	14138	11	1417.9	14171	11	1438.1
14105	11	1397.7	14139	11	1418.5	14172	11	1438.7
14106	11	1398.3				14173	11	1439.3
14107	11	1398.9	14140	11	1419.1	14174	11	1439.9
14108	11	1399.5	14141	11	1419.7	14175	11	1440.5
14109	11	1400.1	14142	11	1420.3	14176	11	1441.1
			14143	11	1421.0	14177	11	1441.7
14110	11	1400.8	14144	11	1421.6	14178	11	1442.3
14111	11	1401.4	14145	11	1422.2	14179	11	1442.9
14112	11	1402.0	14146	11	1422.8			
14113	11	1402.6	14147	11	1423.4	14180	11	1443.5
14114	11	1403.2	14148	11	1424.0	14181	11	1444.1
14115	11	1403.8	14149	11	1424.6	14182	11	1444.7
14116	11	1404.4				14183	11	1445.3
14117	11	1405.0	14150	11	1425.2	14184	11	1446.0
14118	11	1405.7	14151	11	1425.9	14185	11	1446.6
14119	11	1406.3	14152	11	1426.5	14186	11	1447.2
			14153	11	1427.1	14187	11	1447.8
14120	11	1406.9	14154	11	1427.7	14188	11	1448.4
14121	11	1407.5	14155	11	1428.3	14189	11	1449.0
14122	11	1408.1	14156	11	1428.9			
14123	11	1408.7	14157	11	1429.5	14190	11	1449.6
14124	11	1409.3	14158	11	1430.1	14191	11	1450.2
14125	11	1409.9	14159	11	1430.7	14192	11	1450.8
14126	11	1410.6				14193	11	1451.4
14127	11	1411.2	14160	11	1431.4	14194	11	1452.0
14128	11	1411.8	14161	11	1432.0	14195	11	1452.6
14129	11	1412.4	14162	11	1432.6	14196	11	1453.2
			14163	11	1433.2	14197	11	1453.8
14130	11	1413.0	14164	11	1433.8	14198	11	1454.4
14131	11	1413.6	14165	11	1434.4	14199	11	1455.0
14132	11	1414.2	14166	11	1435.0			
14133	11	1414.8	14167	11	1435.6	14200	11	1455.6

Use check point at 14400 Kc

Frequency: 14300—14400 Kc

Freq.	A	B	Freq.	A	B	Freq.	A	B
14300	11	1517.1	14334	11	1538.0	14368	11	1559.1
14301	11	1517.7	14335	11	1538.6	14369	11	1559.7
14302	11	1518.4	14336	11	1539.3			
14303	11	1519.0	14337	11	1539.9	14370	11	1560.3
14304	11	1519.6	14338	11	1540.5	14371	11	1560.9
14305	11	1520.2	14339	11	1541.1	14372	11	1561.5
14306	11	1520.8				14373	11	1562.1
14307	11	1521.4	14340	11	1541.7	14374	11	1562.8
14308	11	1522.1	14341	11	1542.3	14375	11	1563.4
14309	11	1522.7	14342	11	1543.0	14376	11	1564.0
			14343	11	1543.6	14377	11	1564.6
14310	11	1523.3	14344	11	1544.2	14378	11	1565.2
14311	11	1523.9	14345	11	1544.8	14379	11	1565.9
14312	11	1524.5	14346	11	1545.4			
14313	11	1525.1	14347	11	1546.1	14380	11	1566.5
14314	11	1525.7	14348	11	1546.7	14381	11	1567.1
14315	11	1526.4	14349	11	1547.3	14382	11	1567.7
14316	11	1527.0				14383	11	1568.3
14317	11	1527.6	14350	11	1547.9	14384	11	1569.0
14318	11	1528.2	14351	11	1548.5	14385	11	1569.6
14319	11	1528.8	14352	11	1549.1	14386	11	1570.2
			14353	11	1549.8	14387	11	1570.8
14320	11	1529.4	14354	11	1550.4	14388	11	1571.4
14321	11	1530.0	14355	11	1551.0	14389	11	1572.1
14322	11	1530.7	14356					

**TABLE 6-10. CALIBRATION OF HIGH FREQUENCY OSCILLATOR
2000KC TO 18100KC**

Frequency: 14400-14500 Kc						Frequency: 14600-14700 Kc											
Freq.	A	B	Freq.	A	B	Freq.	A	B	Freq.	A	B	Freq.	A	B			
14400	12	60.0	14434	12	77.4	14468	12	94.7	14600	12	161.9	14634	12	179.1			
14401	12	60.5	14435	12	77.9	14469	12	95.3	14601	12	162.4	14635	12	179.7			
14402	12	61.0	14436	12	78.4				14602	12	163.0	14636	12	180.2			
14403	12	61.5	14437	12	78.9	14470	12	95.8	14603	12	163.5	14637	12	180.7			
14404	12	62.0	14438	12	79.4	14471	12	96.3	14604	12	164.0	14638	12	181.2			
14405	12	62.6	14439	12	79.9	14472	12	96.8	14605	12	164.5	14639	12	181.7			
14406	12	63.1			14473	12	97.3	14606	12	165.0			14670	12	197.4		
14407	12	63.6	14440	12	80.4	14474	12	97.8	14607	12	165.5	14640	12	182.2			
14408	12	64.1	14441	12	81.0	14475	12	98.3	14608	12	166.0	14641	12	182.7			
14409	12	64.6	14442	12	81.5	14476	12	98.8	14609	12	166.5	14642	12	183.2			
			14443	12	82.0	14477	12	99.3			14643	12	183.7	14671	12	197.9	
14410	12	65.1	14444	12	82.5	14478	12	99.9	14610	12	167.0	14644	12	184.2	14672	12	198.4
14411	12	65.6	14445	12	83.0	14479	12	100.4	14611	12	167.5	14645	12	184.7	14673	12	198.9
14412	12	66.1	14446	12	83.5				14612	12	168.0	14646	12	185.2	14674	12	199.4
14413	12	66.6	14447	12	84.0	14480	12	100.9	14613	12	168.5	14647	12	185.7	14675	12	199.9
14414	12	67.2	14448	12	84.5	14481	12	101.4	14614	12	169.0	14648	12	186.2	14676	12	200.4
14415	12	67.7	14449	12	85.0	14482	12	101.9	14615	12	169.5	14649	12	186.7	14677	12	200.9
14416	12	68.2			14483	12	102.4	14616	12	170.0			14680	12	202.5		
14417	12	68.7	14450	12	85.6	14484	12	102.9	14617	12	170.5	14650	12	187.3	14681	12	203.0
14418	12	69.2	14451	12	86.1	14485	12	103.4	14618	12	171.0	14651	12	187.8	14682	12	203.5
14419	12	69.7	14452	12	86.6	14486	12	103.9	14619	12	171.6	14652	12	188.3	14683	12	204.0
			14453	12	87.1	14487	12	104.5			14653	12	188.8	14684	12	204.5	
14420	12	70.2	14454	12	87.6	14488	12	105.0	14620	12	172.1	14654	12	189.3	14685	12	205.0
14421	12	70.7	14455	12	88.1	14489	12	105.5	14621	12	172.6	14655	12	189.8	14686	12	205.5
14422	12	71.2	14456	12	88.6				14622	12	173.1	14656	12	190.3	14687	12	206.0
14423	12	71.8	14457	12	89.1	14490	12	106.0	14623	12	173.6	14657	12	190.8	14688	12	206.5
14424	12	72.3	14458	12	89.6	14491	12	106.5	14624	12	174.1	14658	12	191.3	14689	12	207.0
14425	12	72.8	14459	12	90.1	14492	12	107.0	14625	12	174.6	14659	12	191.8	14690	12	207.5
14426	12	73.3			14493	12	107.5	14626	12	175.1			14691	12	208.0		
14427	12	73.8	14460	12	90.7	14494	12	108.0	14627	12	175.6	14660	12	192.3	14692	12	208.5
14428	12	74.3	14461	12	91.2	14495	12	108.5	14628	12	176.1	14661	12	192.8	14693	12	209.0
14429	12	74.8	14462	12	91.7	14496	12	109.0	14629	12	176.6	14662	12	193.3	14694	12	209.5
			14463	12	92.2	14497	12	109.5			14663	12	193.8	14695	12	210.0	
14430	12	75.3	14464	12	92.7	14498	12	110.0	14630	12	177.1	14664	12	194.3	14696	12	210.5
14431	12	75.8	14465	12	93.2	14499	12	110.5	14631	12	177.6	14665	12	194.8	14697	12	211.0
14432	12	76.3	14466	12	93.7				14632	12	178.1	14666	12	195.3	14698	12	211.5
14433	12	76.8	14467	12	94.2	14500	12	111.0	14633	12	178.6	14667	12	195.8	14699	12	212.0

Use check point at 14400 Kc

Use check point at 14600 Kc

Frequency: 14500-14600 Kc						Frequency: 14700-14800 Kc											
Freq.	A	B	Freq.	A	B	Freq.	A	B	Freq.	A	B	Freq.	A	B			
14500	12	111.1	14534	12	128.4	14568	12	146.7	14700	12	212.6	14734	12	229.8			
14501	12	111.6	14535	12	128.9	14569	12	147.2	14701	12	213.1	14735	12	230.3			
14502	12	112.1	14536	12	129.5				14702	12	213.6	14736	12	230.8			
14503	12	112.6	14537	12	130.0	14570	12	147.7	14703	12	214.1	14737	12	231.3			
14504	12	113.1	14538	12	130.5	14571	12	148.2	14704	12	214.6	14738	12	231.8			
14505	12	113.7	14539	12	131.0	14572	12	148.7	14705	12	215.1	14739	12	232.3			
14506	12	114.2			14573	12	149.3	14706	12	215.6			14773	12	249.6		
14507	12	114.7	14540	12	131.5	14574	12	149.8	14707	12	216.1	14740	12	232.8			
14508	12	115.2	14541	12	132.0	14575	12	150.3	14708	12	216.6	14741	12	233.3			
14509	12	115.7	14542	12	132.5	14576	12	150.8	14709	12	217.2	14742	12	233.8			
			14543	12	133.0	14577	12	151.3			14743	12	234.3	14774	12	250.1	
14510	12	116.2	14544	12	133.5	14578	12	151.8	14710	12	217.7	14744	12	234.8	14775	12	250.6
14511	12	116.7	14545	12	134.0	14579	12	152.3	14711	12	218.2	14745	12	235.3	14776	12	251.1
14512	12	117.2	14546	12	134.5				14712	12	218.7	14746	12	235.8	14777	12	251.6
14513	12	117.7	14547	12	135.0	14580	12	152.8	14713	12	219.2	14747	12	236.3	14778	12	252.1
14514	12	118.2	14548	12	135.5	14581	12	153.3	14714	12	219.7	14748	12	236.8	14779	12	252.6
14515	12	118.7	14549	12	136.0	14582	12	153.8	14715	12	220.2	14749	12	237.3	14780	12	253.1
14516	12	119.2			14583	12	154.3	14716	12	220.7			14781	12	253.6		
14517	12	119.7	14550	12	136.6	14584	12	154.8	14717	12	221.2	14750	12	237.8	14782	12	254.1
14518	12	120.2	14551	12	137.1	14585	12	155.3	14718	12	221.7	14751	12	238.3	14783	12	254.6
14519	12	120.7	14552	12	137.6	14586	12	155.8	14719	12	222.2	14752	12	238.8	14784	12	255.1
			14553	12	138.1	14587	12	156.3			14753	12	239.3	14785	12	255.6	
14520	12	121.2	14554	12	138.6	14588	12	156.8	14720	12	222.7	14754	12	239.8	14786	12	256.1
14521	12	121.7	14555	12	139.1	14589	12	157.3	14721	12	223.2	14755	12	240.3	14787	12	256.6
14522	12	122.2	14556	12	139.6				14722	12	223.7	14756	12	240.8	14788	12	257.1
14523	12	122.7	14557	12	140.1	14590	12	157.8	14723	12	224.2	14757	12	241.3	14789	12	257.6
14524	12	123.2	14558	12	140.6	14591	12	158.3	14724	12	224.7	14758	12	241.8	14790	12	258.1
14525	12	123.7	14559	12	141.1	14592	12	158.8	14725	12	225.2	14759	12	242.3	14791	12	258.6
14526	12	124.2			14593	12	159.3	14726	12	225.7			14792	12	259.1		
14527	12	124.7	14560	12	141.7	14594	12	159.8	14727	12	226.2	14760	12	242.8	14793	12	259.6
14528	12	125.2	14561	12	142.2	14595	12	160.3	14728	12	226.7	14761	12	243.3	14794	12	260.1
14529	12	125.7	14562	12	142.7	14596	12	160.8	14729	12	227.2	14762	12	243.8	14795	12	260.6
			14563	12	143.2	14597	12	161.3			14763	12	244.3	14796	12	261.1	
14530	12	126.2	14564	12	143.7	14598	12	161.8	14730	12	227.7	14764	12	244.8	14797	12	261.6
14531	12	126.7	14565	12	144.2	14599	12	162.3	14731	12	228.2	14765	12	245.3	14798	12	262.1
14532	12	127.2	14566	12	144.7				14732	12	228.7	14766	12	245.8	14799	12	262.6
14533	12	127.7	14567	12	145.2	14600	12	162.8	14733	12	229.2	14767	12	246.3	14800	12	263.1

Use check point at 14400 Kc

Use check point at 15000 Kc

**TABLE 6-10. CALIBRATION OF HIGH FREQUENCY OSCILLATOR
2000KC TO 18100KC**

Frequency: 14800-14900 Kc

Freq.	A	B	Freq.	A	B	Freq.	A	B
14800	12 263.3		14834	12 280.6		14868	12 297.8	
14801	12 263.8		14835	12 281.1		14869	12 298.3	
14802	12 264.3		14836	12 281.6				
14803	12 264.8		14837	12 282.1	14870	12 298.8		
14804	12 265.4		14838	12 282.6	14871	12 299.3		
14805	12 265.9		14839	12 283.1	14872	12 299.8		
14806	12 266.4				14873	12 300.4		
14807	12 266.9		14840	12 283.6	14874	12 300.9		
14808	12 267.4		14841	12 284.1	14875	12 301.4		
14809	12 267.9		14842	12 284.6	14876	12 301.9		
			14843	12 285.2	14877	12 302.4		
14810	12 268.4		14844	12 285.7	14878	12 302.9		
14811	12 268.9		14845	12 286.2	14879	12 303.4		
14812	12 269.4		14846	12 286.7				
14813	12 269.9		14847	12 287.2	14880	12 303.9		
14814	12 270.4		14848	12 287.7	14881	12 304.4		
14815	12 271.0		14849	12 288.2	14882	12 304.9		
14816	12 271.5				14883	12 305.4		
14817	12 272.0		14850	12 288.7	14884	12 305.9		
14818	12 272.5		14851	12 289.2	14885	12 306.4		
14819	12 273.0		14852	12 289.7	14886	12 307.0		
			14853	12 290.2	14887	12 307.5		
14820	12 273.5		14854	12 290.7	14888	12 308.0		
14821	12 274.0		14855	12 291.2	14889	12 308.5		
14822	12 274.5		14856	12 291.7				
14823	12 275.0		14857	12 292.2	14890	12 309.0		
14824	12 275.5		14858	12 292.8	14891	12 309.5		
14825	12 276.0		14859	12 293.3	14892	12 310.0		
14826	12 276.5				14893	12 310.5		
14827	12 277.0		14860	12 293.8	14894	12 311.0		
14828	12 277.6		14861	12 294.3	14895	12 311.5		
14829	12 278.1		14862	12 294.8	14896	12 312.1		
			14863	12 295.3	14897	12 312.6		
14830	12 278.6		14864	12 295.8	14898	12 313.1		
14831	12 279.1		14865	12 296.3	14899	12 313.6		
14832	12 279.6		14866	12 296.8				
14833	12 280.1		14867	12 297.3	14900	12 314.1		

Use check point at 15000 Kc

Frequency: 15000-15100 Kc

Freq.	A	B	Freq.	A	B	Freq.	A	B
15000	12 365.2		15034	12 382.4	15068	12 399.7		
15001	12 365.7		15035	12 382.9	15069	12 400.2		
15002	12 366.2		15036	12 383.4				
15003	12 366.7		15037	12 383.9	15070	12 400.7		
15004	12 367.2		15038	12 384.5	15071	12 401.3		
15005	12 367.7		15039	12 385.0	15072	12 401.8		
15006	12 368.2				15073	12 402.3		
15007	12 368.7		15040	12 385.5	15074	12 402.8		
15008	12 369.2		15041	12 386.0	15075	12 403.3		
15009	12 369.7		15042	12 386.5	15076	12 403.8		
			15043	12 387.0	15077	12 404.3		
15010	12 370.2		15044	12 387.5	15078	12 404.8		
15011	12 370.7		15045	12 388.0	15079	12 405.4		
15012	12 371.3		15046	12 388.5				
15013	12 371.8		15047	12 389.0	15080	12 405.9		
15014	12 372.3		15048	12 389.5	15081	12 406.4		
15015	12 372.8		15049	12 390.0	15082	12 406.9		
15016	12 373.3				15083	12 407.4		
15017	12 373.8		15050	12 390.5	15084	12 407.9		
15018	12 374.3		15051	12 391.1	15085	12 408.4		
15019	12 374.8		15052	12 391.6	15086	12 408.9		
			15053	12 392.1	15087	12 409.5		
15020	12 375.3		15054	12 392.6	15088	12 410.0		
15021	12 375.8		15055	12 393.1	15089	12 410.5		
15022	12 376.3		15056	12 393.6				
15023	12 376.8		15057	12 394.1	15090	12 411.0		
15024	12 377.3		15058	12 394.6	15091	12 411.5		
15025	12 377.9		15059	12 395.1	15092	12 412.0		
15026	12 378.4				15093	12 412.5		
15027	12 378.9		15060	12 395.6	15094	12 413.1		
15028	12 379.4		15061	12 396.1	15095	12 413.6		
15029	12 379.9		15062	12 396.6	15096	12 414.1		
			15063	12 397.2	15097	12 414.6		
15030	12 380.4		15064	12 397.7	15098	12 415.1		
15031	12 380.9		15065	12 398.2	15099	12 415.6		
15032	12 381.4		15066	12 398.7				
15033	12 381.9		15067	12 399.2	15100	12 416.1		

Use check point at 15000 Kc

Frequency: 14900-15000 Kc

Freq.	A	B	Freq.	A	B	Freq.	A	B
14900	12 314.1		14934	12 331.4	14968	12 348.8		
14901	12 314.6		14935	12 331.9	14969	12 349.3		
14902	12 315.1		14936	12 332.4				
14903	12 315.6		14937	12 333.0	14970	12 349.8		
14904	12 316.1		14938	12 333.5	14971	12 350.3		
14905	12 316.6		14939	12 334.0	14972	12 350.8		
14906	12 317.2				14973	12 351.4		
14907	12 317.7		14940	12 334.5	14974	12 351.9		
14908	12 318.2		14941	12 335.0	14975	12 352.4		
14909	12 318.7		14942	12 335.5	14976	12 352.9		
			14943	12 336.0	14977	12 353.4		
14910	12 319.2		14944	12 336.5	14978	12 353.9		
14911	12 319.7		14945	12 337.0	14979	12 354.4		
14912	12 320.2		14946	12 337.5				
14913	12 320.7		14947	12 338.1	14980	12 354.9		
14914	12 321.2		14948	12 338.6	14981	12 355.4		
14915	12 321.7		14949	12 339.1	14982	12 356.0		
14916	12 322.2				14983	12 356.5		
14917	12 322.8		14950	12 339.6	14984	12 357.0		
14918	12 323.3		14951	12 340.1	14985	12 357.5		
14919	12 323.8		14952	12 340.6	14986	12 358.0		
			14953	12 341.1	14987	12 358.5		
14920	12 324.3		14954	12 341.6	14988	12 359.0		
14921	12 324.8		14955	12 342.2	14989	12 359.5		
14922	12 325.3		14956	12 342.7				
14923	12 325.8		14957	12 343.2	14990	12 360.0		
14924	12 326.3		14958	12 343.7	14991	12 360.6		
14925	12 326.8		14959	12 344.2	14992	12 361.1		
14926	12 327.3				14993	12 361.6		
14927	12 327.9		14960	12 344.7	14994	12 362.1		
14928	12 328.4		14961	12 345.2	14995	12 362.6		
14929	12 328.9		14962	12 345.7	14996	12 363.1		
			14963	12 346.2	14997	12 363.6		
14930	12 329.4		14964	12 346.8	14998	12 364.1		
14931	12 329.9		14965	12 347.3	14999	12 364.6		
14932	12 330.4		14966	12 347.8				
14933	12 330.9		14967	12 348.3	15000	12 365.2		

Use check point at 15000 Kc

Frequency: 15100-15200 Kc

Freq.	A	B	Freq.	A	B	Freq.	A	B
15100	12 416.1		15134	12 433.6	15168	12 451.1		
15101	12 416.6		15135	12 434.1	15169	12 451.6		
15102	12 417.2		15136	12 434.6				
15103	12 417.7		15137	12 435.1	15170	12 452.1		
15104	12 418.2		15138	12 435.6	15171	12 452.6		
15105	12 418.7		15139	12 436.2	15172	12 453.1		
15106	12 419.2				15173	12 453.6		
15107	12 419.7		15140	12 436.7	15174	12 454.2		
15108	12 420.2		15141	12 437.2	15175	12 454.7		
15109	12 420.7		15142	12 437.7	15176	12 455.2		
			15143	12 438.2	15177	12 455.7		
15110	12 421.3		15144	12 438.7	15178	12 456.2		
15111	12 421.8		15145	12 439.2	15179	12 456.7		
15112	12 422.3		15146	12 439.8				
15113	12 422.8		15147	12 440.3	15180	12 457.2		
15114	12 423.3		15148	12 440.8	15181	12 457.7		
15115	12 423.8		15149	12 441.3	15182	12 458.3		
15116	12 424.3				15183	12 458.8		
15117	12 424.8		15150	12 441.8	15184	12 459.3		
15118	12 425.4		15151	12 442.3	15185	12 459.8		
15119	12 425.9		15152	12 442.8	15186	12 460.3		
			15153	12 443.4	15187	12 460.8		
15120	12 426.4		15154	12 443.9	15188	12 461.3		
15121	12 426.9		15155	12 444.4	15189	12 461.8		
15122	12 427.4		15156	12 444.9				
15123	12 427.9		15157	12 445.4	15190	12 462.3		
15124	12 428.4		15158	12 445.9	15191	12 462.8		
15125	12 429.0		15159	12 446.4	15192	12 463.4		
15126	12 429.5				15193	12 463.9		

**TABLE 6-10. CALIBRATION OF HIGH FREQUENCY OSCILLATOR
2000KC TO 18100KC**

Frequency: 15200-15300 Kc

Freq.	A	B	Freq.	A	B	Freq.	A	B
15200	12 467.4		15234	12 484.8		15268	12 502.3	
15201	12 467.9		15235	12 485.3		15269	12 502.9	
15202	12 468.5		15236	12 485.8				
15203	12 469.0		15237	12 486.3		15270	12 503.4	
15204	12 469.5		15238	12 486.8		15271	12 503.9	
15205	12 470.0		15239	12 487.3		15272	12 504.4	
15206	12 470.5					15273	12 504.9	
15207	12 471.0		15240	12 487.8		15274	12 505.4	
15208	12 471.5		15241	12 488.3		15275	12 506.0	
15209	12 472.0		15242	12 488.9		15276	12 506.5	
			15243	12 489.4		15277	12 507.0	
15210	12 472.5		15244	12 489.9		15278	12 507.5	
15211	12 473.0		15245	12 490.4		15279	12 508.0	
15212	12 473.5		15246	12 490.9				
15213	12 474.1		15247	12 491.4		15280	12 508.6	
15214	12 474.6		15248	12 492.0		15281	12 509.1	
15215	12 475.1		15249	12 492.5		15282	12 509.6	
15216	12 475.6					15283	12 510.1	
15217	12 476.1		15250	12 493.0		15284	12 510.6	
15218	12 476.6		15251	12 493.5		15285	12 511.1	
15219	12 477.1		15252	12 494.0		15286	12 511.7	
			15253	12 494.6		15287	12 512.2	
15220	12 477.6		15254	12 495.1		15288	12 512.7	
15221	12 478.1		15255	12 495.6		15289	12 513.2	
15222	12 478.6		15256	12 496.1				
15223	12 479.2		15257	12 496.6		15290	12 513.7	
15224	12 479.7		15258	12 497.2		15291	12 514.3	
15225	12 480.2		15259	12 497.7		15292	12 514.8	
15226	12 480.7					15293	12 515.3	
15227	12 481.2		15260	12 498.2		15294	12 515.8	
15228	12 481.7		15261	12 498.7		15295	12 516.3	
15229	12 482.2		15262	12 499.2		15296	12 516.8	
			15263	12 499.7		15297	12 517.4	
15230	12 482.7		15264	12 500.3		15298	12 517.9	
15231	12 483.2		15265	12 500.8		15299	12 518.4	
15232	12 483.7		15266	12 501.3				
15233	12 484.3		15267	12 501.8		15300	12 518.9	

Use check point at 15000 Kc

Frequency: 15400-15500 Kc

Freq.	A	B	Freq.	A	B	Freq.	A	B
15400	12 570.3		15434	12 587.8		15468	12 605.4	
15401	12 570.8		15435	12 588.3		15469	12 605.9	
15402	12 571.3		15436	12 588.8				
15403	12 571.8		15437	12 589.4		15470	12 606.4	
15404	12 572.4		15438	12 589.9		15471	12 606.9	
15405	12 572.9		15439	12 590.4		15472	12 607.4	
15406	12 573.4					15473	12 608.0	
15407	12 573.9		15440	12 590.9		15474	12 608.5	
15408	12 574.4		15441	12 591.4		15475	12 609.0	
15409	12 574.9		15442	12 591.9		15476	12 609.5	
			15443	12 592.5		15477	12 610.0	
15410	12 575.4		15444	12 593.0		15478	12 610.5	
15411	12 576.0		15445	12 593.5		15479	12 611.1	
15412	12 576.5		15446	12 594.0				
15413	12 577.0		15447	12 594.5		15480	12 611.6	
15414	12 577.5		15448	12 595.0		15481	12 612.1	
15415	12 578.0		15449	12 595.6		15482	12 612.6	
15416	12 578.5					15483	12 613.1	
15417	12 579.0		15450	12 596.1		15484	12 613.6	
15418	12 579.6		15451	12 596.6		15485	12 614.2	
15419	12 580.1		15452	12 597.1		15486	12 614.7	
			15453	12 597.6		15487	12 615.2	
15420	12 580.6		15454	12 598.1		15488	12 615.7	
15421	12 581.1		15455	12 598.7		15489	12 616.2	
15422	12 581.6		15456	12 599.2				
15423	12 582.1		15457	12 599.7		15490	12 616.7	
15424	12 582.6		15458	12 600.2		15491	12 617.2	
15425	12 583.2		15459	12 600.7		15492	12 617.8	
15426	12 583.7					15493	12 618.3	
15427	12 584.2		15460	12 601.2		15494	12 618.8	
15428	12 584.7		15461	12 601.8		15495	12 619.3	
15429	12 585.2		15462	12 602.3		15496	12 619.8	
			15463	12 602.8		15497	12 620.3	
15430	12 585.7		15464	12 603.3		15498	12 620.9	
15431	12 586.3		15465	12 603.8		15499	12 621.4	
15432	12 586.8		15466	12 604.3				
15433	12 587.3		15467	12 604.9		15500	12 621.9	

Use check point at 15600 Kc

Frequency: 15300-15400 Kc

Freq.	A	B	Freq.	A	B	Freq.	A	B
15300	12 518.9		15334	12 536.4		15368	12 553.8	
15301	12 519.4		15335	12 536.9		15369	12 554.3	
15302	12 519.9		15336	12 537.4				
15303	12 520.5		15337	12 537.9		15370	12 554.9	
15304	12 521.0		15338	12 538.4		15371	12 555.4	
15305	12 521.5		15339	12 538.9		15372	12 555.9	
15306	12 522.0					15373	12 556.4	
15307	12 522.5		15340	12 539.5		15374	12 556.9	
15308	12 523.0		15341	12 540.0		15375	12 557.4	
15309	12 523.5		15342	12 540.5		15376	12 557.9	
			15343	12 541.0		15377	12 558.5	
15310	12 524.1		15344	12 541.5		15378	12 559.0	
15311	12 524.6		15345	12 542.0		15379	12 559.5	
15312	12 525.1		15346	12 542.5				
15313	12 525.6		15347	12 543.0		15380	12 560.0	
15314	12 526.1		15348	12 543.6		15381	12 560.5	
15315	12 526.6		15349	12 544.1		15382	12 561.0	
15316	12 527.1					15383	12 561.5	
15317	12 527.6		15350	12 544.6		15384	12 562.1	
15318	12 528.2		15351	12 545.1		15385	12 562.6	
15319	12 528.7		15352	12 545.6		15386	12 563.1	
			15353	12 546.1		15387	12 563.6	
15320	12 529.2		15354	12 546.6		15388	12 564.1	
15321	12 529.7		15355	12 547.2		15389	12 564.6	
15322	12 530.2		15356	12 547.7				
15323	12 530.7		15357	12 548.2		15390	12 565.2	
15324	12 531.2		15358	12 548.7		15391	12 565.7	
15325	12 531.8		15359	12 549.2		15392	12 566.2	
15326	12 532.3					15393	12 566.7	
15327	12 532.8		15360	12 549.7		15394	12 567.2	
15328	12 533.3		15361	12 550.2		15395	12 567.7	
15329	12 533.8		15362	12 550.7		15396	12 568.2	
			15363	12 551.3		15397	12 568.8	
15330	12 534.3		15364	12 551.8		15398	12 569.3	
15331	12 534.8		15365	12 552.3		15399	12 569.8	
15332	12 535.3		15366	12 552.8				
15333	12 535.9		15367	12 553.3		15400	12 570.3	

Use check point at 15600 Kc

Frequency: 15500-15600 Kc

Freq.	A	B	Freq.	A	B	Freq.	A	B
15500	12 621.9		15534	12 639.4		15568	12 656.9	
15501	12 622.4		15535	12 639.9		15569	12 657.4	
15502	12 622.9		15536	12 640.4				
15503	12 623.4		15537	12 641.0		15570	12 658.0	
15504	12 623.9		15538	12 641.5		15571	12 658.5	
15505	12 624.5		15539	12 642.0		15572	12 659.0	
15506	12 625.0					15573	12 659.5	
15507	12 625.5		15540	12 642.5		15574	12 660.0	
15508	12 626.0		15541	12 643.0		15575	12 660.5	
15509	12 626.5		15542	12 643.5		15576	12 661.1	
			15543	12 644.0		15577	12 661.6	
15510	12 627.0		15544	12 644.6		15578	12 662.1	
15511	12 627.6		15545	12 645.1		15579	12 662.6	
15512	12 628.1		15546	12 645.6				
15513	12 628.6		15547	12 646.1		15580	12 663.1	
15514	12 629.1		15548	12 646.6		15581	12 663.6	
15515	12 629.6		15549	12 647.1		15582	12 664.1	
15516	12 630.1					15583	12 664.7	
15517	12 630.6		15550	12 647.7		15584	12 665.2	
15518	12 631.2		15551	12 648.2		15585	12 665.7	
15519	12 631.7		15552	12 648.7		15586	12 666.2	
			15553	12 649.2		15587	12 666.7	
15520	12 632.2		15554	12 649.7		15588	12 667.2	
15521	12 632.7		15555	12 650.2		15589	12 667.8	
15522	12 633.2		15556	12 650.7				
15523	12 633.7		15557	12 651.3		15590	12 668.3	
15524	12 634.3		15558	12 651.8		15591	12 668.8	
15525	12 634.8		15559	12 652.3		15592	12 669.3	
15526	12 635.3					15593	12 669.8	
15527								

**TABLE 6-10. CALIBRATION OF HIGH FREQUENCY OSCILLATOR
2000KC TO 18100KC**

Frequency: 15600-15700 Kc						Frequency: 15800-15900 Kc								
Freq.	A	B	Freq.	A	B	Freq.	A	B	Freq.	A	B	Freq.	A	B
15600	12	673.4	15634	12	690.9	15668	12	708.4	15800	12	776.3	15834	12	793.8
15601	12	673.9	15635	12	691.4	15669	12	708.9	15801	12	776.8	15835	12	794.3
15602	12	674.4	15636	12	691.9				15802	12	777.3	15836	12	794.8
15603	12	675.0	15637	12	692.4	15670	12	709.4	15803	12	777.8	15837	12	795.3
15604	12	675.5	15638	12	692.9	15671	12	709.9	15804	12	778.3	15838	12	795.8
15605	12	676.0	15639	12	693.5	15672	12	710.4	15805	12	778.8	15839	12	796.3
15606	12	676.5				15673	12	711.0	15806	12	779.4			
15607	12	677.0	15640	12	694.0	15674	12	711.5	15807	12	779.9	15840	12	796.9
15608	12	677.5	15641	12	694.5	15675	12	712.0	15808	12	780.4	15841	12	797.4
15609	12	678.0	15642	12	695.0	15676	12	712.5	15809	12	780.9	15842	12	797.9
			15643	12	695.5	15677	12	713.0				15843	12	798.4
15610	12	678.6	15644	12	696.0	15678	12	713.5	15810	12	781.4	15844	12	798.9
15611	12	679.1	15645	12	696.5	15679	12	714.1	15811	12	781.9	15845	12	799.5
15612	12	679.6	15646	12	697.0				15812	12	782.4	15846	12	800.0
15613	12	680.1	15647	12	697.6	15680	12	714.6	15813	12	783.0	15847	12	800.5
15614	12	680.6	15648	12	698.1	15681	12	715.1	15814	12	783.5	15848	12	801.0
15615	12	681.1	15649	12	698.6	15682	12	715.6	15815	12	784.0	15849	12	801.5
15616	12	681.6				15683	12	716.1	15816	12	784.5			
15617	12	682.2	15650	12	699.1	15684	12	716.6	15817	12	785.0	15850	12	802.0
15618	12	682.7	15651	12	699.6	15685	12	717.2	15818	12	785.5	15851	12	802.6
15619	12	683.2	15652	12	700.1	15686	12	717.7	15819	12	786.0	15852	12	803.1
			15653	12	700.6	15687	12	718.2				15853	12	803.6
15620	12	683.7	15654	12	701.2	15688	12	718.7	15820	12	786.6	15854	12	804.1
15621	12	684.2	15655	12	701.7	15689	12	719.2	15821	12	787.1	15855	12	804.6
15622	12	684.7	15656	12	702.2				15822	12	787.6	15856	12	805.2
15623	12	685.2	15657	12	702.7	15690	12	719.8	15823	12	788.1	15857	12	805.7
15624	12	685.7	15658	12	703.2	15691	12	720.3	15824	12	788.6	15858	12	806.2
15625	12	686.3	15659	12	703.7	15692	12	720.8	15825	12	789.1	15859	12	806.7
15626	12	686.8				15693	12	721.3	15826	12	789.7			
15627	12	687.3	15660	12	704.2	15694	12	721.8	15827	12	790.2	15860	12	807.2
15628	12	687.8	15661	12	704.8	15695	12	722.3	15828	12	790.7	15861	12	807.7
15629	12	688.3	15662	12	705.3	15696	12	722.9	15829	12	791.2	15862	12	808.3
			15663	12	705.8	15697	12	723.4				15863	12	808.8
15630	12	688.8	15664	12	706.3	15698	12	723.9	15830	12	791.7	15864	12	809.3
15631	12	689.3	15665	12	706.8	15699	12	724.4	15831	12	792.2	15865	12	809.8
15632	12	689.9	15666	12	707.3				15832	12	792.7	15866	12	810.3
15633	12	690.4	15667	12	707.9	15700	12	724.9	15833	12	793.3	15867	12	810.9

Use check point at 15600 Kc

Use check point at 15600 Kc

Frequency: 15700-15800 Kc					
Freq.	A	B	Freq.	A	B
15700	12	724.9	15734	12	742.4
15701	12	725.4	15735	12	742.9
15702	12	726.0	15736	12	743.4
15703	12	726.5	15737	12	744.0
15704	12	727.0	15738	12	744.5
15705	12	727.5	15739	12	745.0
15706	12	728.0			
15707	12	728.5	15740	12	745.5
15708	12	729.1	15741	12	746.0
15709	12	729.6	15742	12	746.5
			15743	12	747.0
15710	12	730.1	15744	12	747.5
15711	12	730.6	15745	12	748.1
15712	12	731.1	15746	12	748.6
15713	12	731.6	15747	12	749.1
15714	12	732.2	15748	12	749.6
15715	12	732.7	15749	12	750.1
15716	12	733.2			
15717	12	733.7	15750	12	750.6
15718	12	734.2	15751	12	751.1
15719	12	734.7	15752	12	751.6
			15753	12	752.1
15720	12	735.3	15754	12	752.7
15721	12	735.8	15755	12	753.2
15722	12	736.3	15756	12	753.7
15723	12	736.8	15757	12	754.2
15724	12	737.3	15758	12	754.7
15725	12	737.8	15759	12	755.2
15726	12	738.3			
15727	12	738.8	15760	12	755.7
15728	12	739.4	15761	12	756.2
15729	12	739.9	15762	12	756.8
			15763	12	757.3
15730	12	740.4	15764	12	757.8
15731	12	740.9	15765	12	758.3
15732	12	741.4	15766	12	758.8
15733	12	741.9	15767	12	759.3
			15800	12	776.3

Use check point at 15600 Kc

Frequency: 15900-16000 Kc					
Freq.	A	B	Freq.	A	B
15900	12	828.0	15934	12	845.4
15901	12	828.5	15935	12	845.9
15902	12	829.0	15936	12	846.4
15903	12	829.5	15937	12	847.0
15904	12	830.0	15938	12	847.5
15905	12	830.5	15939	12	848.0
15906	12	831.0			
15907	12	831.6	15940	12	848.5
15908	12	832.1	15941	12	849.0
15909	12	832.6	15942	12	849.5
			15943	12	850.0
15910	12	833.1	15944	12	850.5
15911	12	833.6	15945	12	851.1
15912	12	834.1	15946	12	851.6
15913	12	834.6	15947	12	852.1
15914	12	835.1	15948	12	852.6
15915	12	835.7	15949	12	853.1
15916	12	836.2			
15917	12	836.7	15950	12	853.6
15918	12	837.2	15951	12	854.1
15919	12	837.7	15952	12	854.7
			15953	12	855.2
15920	12	838.2	15954	12	855.7
15921	12	838.7	15955	12	856.2
15922	12	839.3	15956	12	856.7
15923	12	839.8	15957	12	857.2
15924	12	840.3	15958	12	857.7
15925	12	840.8	15959	12	858.2
15926	12	841.3			
15927	12	841.8	15960	12	858.8
15928	12	842.3	15961	12	859.3
15929	12	842.8	15962	12	859.8
			15963	12	860.3
15930	12	843.4	15964	12	860.8
15931	12	843.9	15965	12	861.3
15932	12	844.4	15966	12	861.8
15933	12	844.9	15967	12	862.3
			16000	12	879.0

Use check point at 16200 Kc

**TABLE 6-10. CALIBRATION OF HIGH FREQUENCY OSCILLATOR
2000KC TO 18100KC**

Frequency: 16000-16100 Kc

Freq.	A	B	Freq.	A	B	Freq.	A	B
16000	12	879.0	16034	12	896.3	16068	12	913.8
16001	12	879.5	16035	12	896.9	16069	12	914.4
16002	12	880.0	16036	12	897.4			
16003	12	880.5	16037	12	897.9	16070	12	914.9
16004	12	881.0	16038	12	898.4	16071	12	915.4
16005	12	881.5	16039	12	898.9	16072	12	915.9
16006	12	882.1				16073	12	916.4
16007	12	882.6	16040	12	899.4	16074	12	916.9
16008	12	883.1	16041	12	899.9	16075	12	917.4
16009	12	883.6	16042	12	900.5	16076	12	918.0
			16043	12	901.0	16077	12	918.5
16010	12	884.1	16044	12	901.5	16078	12	919.0
16011	12	884.6	16045	12	902.0	16079	12	919.5
16012	12	885.1	16046	12	902.5			
16013	12	885.6	16047	12	903.0	16080	12	920.0
16014	12	886.1	16048	12	903.6	16081	12	920.5
16015	12	886.6	16049	12	904.1	16082	12	921.0
16016	12	887.1				16083	12	921.6
16017	12	887.6	16050	12	904.6	16084	12	922.1
16018	12	888.1	16051	12	905.1	16085	12	922.6
16019	12	888.6	16052	12	905.6	16086	12	923.1
			16053	12	906.1	16087	12	923.6
16020	12	889.1	16054	12	906.6	16088	12	924.1
16021	12	889.7	16055	12	907.2	16089	12	924.6
16022	12	890.2	16056	12	907.7			
16023	12	890.7	16057	12	908.2	16090	12	925.1
16024	12	891.2	16058	12	908.7	16091	12	925.6
16025	12	891.7	16059	12	909.2	16092	12	926.1
16026	12	892.2				16093	12	926.7
16027	12	892.7	16060	12	909.7	16094	12	927.2
16028	12	893.3	16061	12	910.2	16095	12	927.7
16029	12	893.8	16062	12	910.8	16096	12	928.2
			16063	12	911.3	16097	12	928.7
16030	12	894.3	16064	12	911.8	16098	12	929.2
16031	12	894.8	16065	12	912.3	16099	12	929.7
16032	12	895.3	16066	12	912.8			
16033	12	895.8	16067	12	913.3	16100	12	930.2

Use check point at 16200 Kc

Frequency: 16200-16300 Kc

Freq.	A	B	Freq.	A	B	Freq.	A	B
16200	12	981.4	16234	12	998.7	16268	12	1016.0
16201	12	981.9	16235	12	999.2	16269	12	1016.5
16202	12	982.4	16236	12	999.7			
16203	12	982.9	16237	12	1000.2	16270	12	1017.0
16204	12	983.4	16238	12	1000.7	16271	12	1017.6
16205	12	983.9	16239	12	1001.3	16272	12	1018.1
16206	12	984.4				16273	12	1018.6
16207	12	984.9	16240	12	1001.8	16274	12	1019.1
16208	12	985.4	16241	12	1002.3	16275	12	1019.6
16209	12	986.0	16242	12	1002.8	16276	12	1020.1
			16243	12	1003.3	16277	12	1020.6
16210	12	986.5	16244	12	1003.8	16278	12	1021.1
16211	12	987.0	16245	12	1004.3	16279	12	1021.6
16212	12	987.5	16246	12	1004.8			
16213	12	988.0	16247	12	1005.3	16280	12	1022.1
16214	12	988.5	16248	12	1005.8	16281	12	1022.6
16215	12	989.0	16249	12	1006.4	16282	12	1023.2
16216	12	989.5				16283	12	1023.7
16217	12	990.0	16250	12	1006.7	16284	12	1024.2
16218	12	990.5	16251	12	1007.4	16285	12	1024.7
16219	12	991.1	16252	12	1007.9	16286	12	1025.2
			16253	12	1008.4	16287	12	1025.7
16220	12	991.6	16254	12	1008.9	16288	12	1026.2
16221	12	992.1	16255	12	1009.4	16289	12	1026.7
16222	12	992.6	16256	12	1009.9			
16223	12	993.1	16257	12	1010.4	16290	12	1027.2
16224	12	993.6	16258	12	1010.9	16291	12	1027.7
16225	12	994.1	16259	12	1011.5	16292	12	1028.2
16226	12	994.6				16293	12	1028.7
16227	12	995.1	16260	12	1012.0	16294	12	1029.3
16228	12	995.6	16261	12	1012.5	16295	12	1029.8
16229	12	996.2	16262	12	1013.0	16296	12	1030.3
			16263	12	1013.5	16297	12	1030.8
16230	12	996.7	16264	12	1014.0	16298	12	1031.3
16231	12	997.2	16265	12	1014.5	16299	12	1031.8
16232	12	997.7	16266	12	1015.0			
16233	12	998.2	16267	12	1015.5	16300	12	1032.3

Use check point at 16200 Kc

Frequency: 16100-16200 Kc

Freq.	A	B	Freq.	A	B	Freq.	A	B
16100	12	930.2	16134	12	947.6	16168	12	965.0
16101	12	930.7	16135	12	948.1	16169	12	965.5
16102	12	931.3	16136	12	948.6			
16103	12	931.8	16137	12	949.1	16170	12	966.0
16104	12	932.3	16138	12	949.6	16171	12	966.5
16105	12	932.8	16139	12	950.1	16172	12	967.0
16106	12	933.3				16173	12	967.5
16107	12	933.8	16140	12	950.7	16174	12	968.1
16108	12	934.3	16141	12	951.2	16175	12	968.6
16109	12	934.8	16142	12	951.7	16176	12	969.1
			16143	12	952.2	16177	12	969.6
16110	12	935.3	16144	12	952.7	16178	12	970.1
16111	12	935.9	16145	12	953.2	16179	12	970.6
16112	12	936.4	16146	12	953.7			
16113	12	936.9	16147	12	954.2	16180	12	971.1
16114	12	937.4	16148	12	954.8	16181	12	971.6
16115	12	937.9	16149	12	955.3	16182	12	972.2
16116	12	938.4				16183	12	972.7
16117	12	938.9	16150	12	955.8	16184	12	973.2
16118	12	939.4	16151	12	956.3	16185	12	973.7
16119	12	939.9	16152	12	956.8	16186	12	974.2
			16153	12	957.3	16187	12	974.7
16120	12	940.4	16154	12	957.8	16188	12	975.2
16121	12	941.0	16155	12	958.3	16189	12	975.7
16122	12	941.5	16156	12	958.8			
16123	12	942.0	16157	12	959.4	16190	12	976.2
16124	12	942.5	16158	12	959.9	16191	12	976.8
16125	12	943.0	16159	12	960.4	16192	12	977.3
16126	12	943.5				16193	12	977.8
16127	12	944.0	16160	12	960.9	16194	12	978.3
16128	12	944.5	16161	12	961.4	16195	12	978.8
16129	12	945.0	16162	12	961.9	16196	12	979.3
			16163	12	962.4	16197	12	979.8
16130	12	945.6	16164	12	962.9	16198	12	980.3
16131	12	946.1	16165	12	963.5	16199	12	980.8
16132	12	946.6	16166	12	964.0			
16133	12	947.1	16167	12	964.5	16200	12	981.4

Use check point at 16200 Kc

Frequency: 16300-16400 Kc

Freq.	A	B	Freq.	A	B	Freq.	A	B
16300	12	1032.3	16334	12	1049.6	16368	12	1066.9
16301	12	1032.8	16335	12	1050.1	16369	12	1067.4
16302	12	1033.3	16336	12	1050.6			
16303	12	1033.8	16337	12	1051.1	16370	12	1067.9
16304	12	1034.3	16338	12	1051.6	16371	12	1068.4
16305	12	1034.9	16339	12	1052.1	16372	12	1068.9
16306	12	1035.4				16373	12	1069.4
16307	12	1035.9	16340	12	1052.6	16374	12	1069.9
16308	12	1036.4	16341	12	1053.2	16375	12	1070.4
16309	12	1036.9	16342	12	1053.7	16376	12	1070.9
			16343	12	1054.2	16377	12	1071.5
16310	12	1037.4	16344	12	1054.7	16378	12	1072.0
16311	12	1037.9	16345	12	1055.2	16379	12	1072.5
16312	12	1038.4	16346	12	1055.7			
16313	12	1038.9	16347	12	1056.2	16380	12	1073.0
16314	12	1039.4	16348	12	1056.7	16381	12	1073.5
16315	12	1039.9	16349	12	1057.2	16382	12	1074.0
16316	12	1040.4				16383	12	1074.5
16317	12	1041.0	16350	12	1057.7	16384	12	1075.0
16318	12	1041.5	16351	12	1058.2	16385	12	1075.5
16319	12	1042.0	16352	12	1058.7	16386	12	1076.0
			16353	12	1059.3	16387	12	1076.5
16320	12	1042.5	16354	12	1059.8	16388	12	1077.0
16321	12	1043.0	16355	12	1060.3	16389	12	1077.5
16322	12	1043.5	16356	12	1060.8			
16323	12	1044.0	16357	12	1061.3	16390	12	1078.1
16324	12	1044.5	16358	12	1061.8	16391	12	1078.6

**TABLE 6-10. CALIBRATION OF HIGH FREQUENCY OSCILLATOR
2000KC TO 18100KC**

Frequency: 16400-16500 Kc

Freq.	A	B	Freq.	A	B	Freq.	A	B
16400	12	1083.1	16434	12	1100.4	16468	12	1117.6
16401	12	1083.6	16435	12	1100.9	16469	12	1118.1
16402	12	1084.1	16436	12	1101.4			
16403	12	1084.7	16437	12	1101.9	16470	12	1118.6
16404	12	1085.2	16438	12	1102.4	16471	12	1119.1
16405	12	1085.7	16439	12	1102.9	16472	12	1119.7
16406	12	1086.2				16473	12	1120.2
16407	12	1086.7	16440	12	1103.4	16474	12	1120.7
16408	12	1087.2	16441	12	1103.9	16475	12	1121.2
16409	12	1087.7	16442	12	1104.5	16476	12	1121.7
			16443	12	1105.0	16477	12	1122.2
16410	12	1088.2	16444	12	1105.5	16478	12	1122.7
16411	12	1088.7	16445	12	1106.0	16479	12	1123.2
16412	12	1089.2	16446	12	1106.5			
16413	12	1089.7	16447	12	1107.0	16480	12	1123.7
16414	12	1090.2	16448	12	1107.5	16481	12	1124.2
16415	12	1090.7	16449	12	1108.0	16482	12	1124.7
16416	12	1091.3				16483	12	1125.2
16417	12	1091.8	16450	12	1108.5	16484	12	1125.7
16418	12	1092.3	16451	12	1109.0	16485	12	1126.2
16419	12	1092.8	16452	12	1109.5	16486	12	1126.7
			16453	12	1110.0	16487	12	1127.3
16420	12	1093.3	16454	12	1110.5	16488	12	1127.8
16421	12	1093.8	16455	12	1111.0	16489	12	1128.3
16422	12	1094.3	16456	12	1111.5			
16423	12	1094.8	16457	12	1112.1	16490	12	1128.8
16424	12	1095.3	16458	12	1112.6	16491	12	1129.3
16425	12	1095.8	16459	12	1113.1	16492	12	1129.8
16426	12	1096.3				16493	12	1130.3
16427	12	1096.8	16460	12	1113.6	16494	12	1130.8
16428	12	1097.3	16461	12	1114.1	16495	12	1131.3
16429	12	1097.9	16462	12	1114.6	16496	12	1131.8
			16463	12	1115.1	16497	12	1132.3
16430	12	1098.4	16464	12	1115.6	16498	12	1132.8
16431	12	1098.9	16465	12	1116.1	16499	12	1133.3
16432	12	1099.4	16466	12	1116.6			
16433	12	1099.9	16467	12	1117.1	16500	12	1133.8

Use check point at 16200 Kc

Frequency: 16600-16700 Kc

Freq.	A	B	Freq.	A	B	Freq.	A	B
16600	12	1184.4	16634	12	1201.5	16668	12	1218.8
16601	12	1184.9	16635	12	1202.1	16669	12	1219.3
16602	12	1185.4	16636	12	1202.6			
16603	12	1185.9	16637	12	1203.1	16670	12	1219.8
16604	12	1186.4	16638	12	1203.6	16671	12	1220.3
16605	12	1186.9	16639	12	1204.1	16672	12	1220.8
16606	12	1187.4				16673	12	1221.3
16607	12	1187.9	16640	12	1204.6	16674	12	1221.9
16608	12	1188.4	16641	12	1205.1	16675	12	1222.4
16609	12	1188.9	16642	12	1205.6	16676	12	1222.9
			16643	12	1206.1	16677	12	1223.4
16610	12	1189.4	16644	12	1206.6	16678	12	1223.9
16611	12	1189.9	16645	12	1207.1	16679	12	1224.4
16612	12	1190.4	16646	12	1207.6			
16613	12	1190.9	16647	12	1208.1	16680	12	1224.9
16614	12	1191.4	16648	12	1208.7	16681	12	1225.4
16615	12	1191.9	16649	12	1209.2	16682	12	1225.9
16616	12	1192.4				16683	12	1226.4
16617	12	1192.9	16650	12	1209.7	16684	12	1226.9
16618	12	1193.4	16651	12	1210.2	16685	12	1227.4
16619	12	1193.9	16652	12	1210.7	16686	12	1227.9
			16653	12	1211.2	16687	12	1228.4
16620	12	1194.4	16654	12	1211.7	16688	12	1228.9
16621	12	1194.9	16655	12	1212.2	16689	12	1229.4
16622	12	1195.5	16656	12	1212.7			
16623	12	1196.0	16657	12	1213.2	16690	12	1229.9
16624	12	1196.5	16658	12	1213.7	16691	12	1230.4
16625	12	1197.0	16659	12	1214.2	16692	12	1230.9
16626	12	1197.5				16693	12	1231.4
16627	12	1198.0	16660	12	1214.7	16694	12	1231.9
16628	12	1198.5	16661	12	1215.3	16695	12	1232.5
16629	12	1199.0	16662	12	1215.8	16696	12	1233.0
			16663	12	1216.3	16697	12	1233.5
16630	12	1199.5	16664	12	1216.8	16698	12	1234.0
16631	12	1200.0	16665	12	1217.3	16699	12	1234.5
16632	12	1200.5	16666	12	1217.8			
16633	12	1201.0	16667	12	1218.3	16700	12	1235.0

Use check point at 16800 Kc

Frequency: 16500-16600 Kc

Freq.	A	B	Freq.	A	B	Freq.	A	B
16500	12	1133.8	16534	12	1151.1	16568	12	1168.2
16501	12	1134.3	16535	12	1151.6	16569	12	1168.8
16502	12	1134.9	16536	12	1152.1			
16503	12	1135.4	16537	12	1152.6	16570	12	1169.3
16504	12	1135.9	16538	12	1153.1	16571	12	1169.8
16505	12	1136.4	16539	12	1153.6	16572	12	1170.3
16506	12	1136.9				16573	12	1170.8
16507	12	1137.4	16540	12	1154.1	16574	12	1171.3
16508	12	1137.9	16541	12	1154.6	16575	12	1171.8
16509	12	1138.4	16542	12	1155.1	16576	12	1172.3
			16543	12	1155.6	16577	12	1172.8
16510	12	1138.9	16544	12	1156.1	16578	12	1173.3
16511	12	1139.4	16545	12	1156.6	16579	12	1173.8
16512	12	1139.9	16546	12	1157.1			
16513	12	1140.4	16547	12	1157.6	16580	12	1174.3
16514	12	1140.9	16548	12	1158.1	16581	12	1174.8
16515	12	1141.4	16549	12	1158.7	16582	12	1175.3
16516	12	1141.9				16583	12	1175.8
16517	12	1142.4	16550	12	1159.2	16584	12	1176.3
16518	12	1143.0	16551	12	1159.7	16585	12	1176.8
16519	12	1143.5	16552	12	1160.2	16586	12	1177.3
			16553	12	1160.7	16587	12	1177.8
16520	12	1144.0	16554	12	1161.2	16588	12	1178.3
16521	12	1144.5	16555	12	1161.7	16589	12	1178.8
16522	12	1145.0	16556	12	1162.2			
16523	12	1145.5	16557	12	1162.7	16590	12	1179.3
16524	12	1146.0	16558	12	1163.2	16591	12	1179.8
16525	12	1146.5	16559	12	1163.7	16592	12	1180.3
16526	12	1147.0				16593	12	1180.8
16527	12	1147.5	16560	12	1164.2	16594	12	1181.3
16528	12	1148.0	16561	12	1164.7	16595	12	1181.8
16529	12	1148.5	16562	12	1165.2	16596	12	1182.4
			16563	12	1165.7	16597	12	1182.9
16530	12	1149.0	16564	12	1166.2	16598	12	1183.4
16531	12	1149.5	16565	12	1166.7	16599	12	1183.9
16532	12	1150.0	16566	12	1167.2			
16533	12	1150.5	16567	12	1167.7	16600	12	1184.4

Use check point at 16800 Kc

Frequency: 16700-16800 Kc

Freq.	A	B	Freq.	A	B	Freq.	A	B
16700	12	1235.0	16734	12	1252.1	16768	12	1269.2
16701	12	1235.5	16735	12	1252.6	16769	12	1269.7
16702	12	1236.0	16736	12	1253.1			
16703	12	1236.5	16737	12	1253.6	16770	12	1270.2
16704	12	1237.0	16738	12	1254.1	16771	12	1270.7
16705	12	1237.5	16739	12	1254.6	16772	12	1271.2
16706	12	1238.0				16773	12	1271.7
16707	12	1238.5	16740	12	1255.1	16774	12	1272.2
16708	12	1239.0	16741	12	1255.6	16775	12	1272.7
16709	12	1239.5	16742	12	1256.1	16776	12	1273.2
			16743	12	1256.6	16777	12	1273.7
16710	12	1240.0	16744	12	1257.1	16778	12	1274.2
16711	12	1240.5	16745	12	1257.6	16779	12	1274.7
16712	12	1241.0	16746	12	1258.1			
16713	12	1241.5	16747	12	1258.6	16780	12	1275.2
16714	12	1242.0	16748	12	1259.1	16781	12	1275.7
16715	12	1242.5	16749	12	1259.6	16782	12	1276.2
16716	12	1243.0				16783	12	1276.7
16717	12	1243.5	16750	12	1260.1	16784	12	1277.2
16718	12	1244.0	16751	12	1260.6	16785	12	1277.8
16719	12	1244.5	16752	12	1261.1	16786	12	1278.3
			16753	12	1261.6	16787	12	1278.8
16720	12	1245.0	16754	12	1262.1	16788	12	1279.3
16721	12	1245.5	16755	12	1262.6	16789	12	1279.8
16722	12	1246.0	16756					

**TABLE 6-10. CALIBRATION OF HIGH FREQUENCY OSCILLATOR
2000KC TO 18100KC**

Frequency: 16800-16900 Kc

Freq.	A	B	Freq.	A	B	Freq.	A	B
16800	12	1285.3	16834	12	1302.5	16868	12	1319.7
16801	12	1285.8	16835	12	1303.0	16869	12	1320.2
16802	12	1286.3	16836	12	1303.5			
16803	12	1286.8	16837	12	1304.0	16870	12	1320.7
16804	12	1287.3	16838	12	1304.5	16871	12	1321.2
16805	12	1287.8	16839	12	1305.0	16872	12	1321.7
16806	12	1288.3				16873	12	1322.2
16807	12	1288.8	16840	12	1305.5	16874	12	1322.7
16808	12	1289.3	16841	12	1306.0	16875	12	1323.2
16809	12	1289.9	16842	12	1306.6	16876	12	1323.7
			16843	12	1307.1	16877	12	1324.2
16810	12	1290.4	16844	12	1307.6	16878	12	1324.8
16811	12	1290.9	16845	12	1308.1	16879	12	1325.3
16812	12	1291.4	16846	12	1308.6			
16813	12	1291.9	16847	12	1309.1	16880	12	1325.8
16814	12	1292.4	16848	12	1309.6	16881	12	1326.3
16815	12	1292.9	16849	12	1310.1	16882	12	1326.8
16816	12	1293.4				16883	12	1327.3
16817	12	1293.9	16850	12	1310.6	16884	12	1327.8
16818	12	1294.4	16851	12	1311.1	16885	12	1328.3
16819	12	1294.9	16852	12	1311.6	16886	12	1328.8
			16853	12	1312.1	16887	12	1329.3
16820	12	1295.4	16854	12	1312.6	16888	12	1329.8
16821	12	1295.9	16855	12	1313.1	16889	12	1330.3
16822	12	1296.4	16856	12	1313.6			
16823	12	1296.9	16857	12	1314.1	16890	12	1330.8
16824	12	1297.4	16858	12	1314.6	16891	12	1331.3
16825	12	1298.0	16859	12	1315.2	16892	12	1331.8
16826	12	1298.5				16893	12	1332.3
16827	12	1299.0	16860	12	1315.7	16894	12	1332.8
16828	12	1299.5	16861	12	1316.2	16895	12	1333.3
16829	12	1300.0	16862	12	1316.7	16896	12	1333.8
			16863	12	1317.2	16897	12	1334.3
16830	12	1300.5	16864	12	1317.7	16898	12	1334.9
16831	12	1301.0	16865	12	1318.2	16899	12	1335.4
16832	12	1301.5	16866	12	1318.7			
16833	12	1302.0	16867	12	1319.2	16900	12	1335.9

Use check point at 16800 Kc

Frequency: 16900-17000 Kc

Freq.	A	B	Freq.	A	B	Freq.	A	B
16900	12	1335.9	16934	12	1353.0	16968	12	1370.2
16901	12	1336.4	16935	12	1353.5	16969	12	1370.7
16902	12	1336.9	16936	12	1354.0			
16903	12	1337.4	16937	12	1354.6	16970	12	1371.2
16904	12	1337.9	16938	12	1355.1	16971	12	1371.7
16905	12	1338.4	16939	12	1355.6	16972	12	1372.2
16906	12	1338.9				16973	12	1372.7
16907	12	1339.4	16940	12	1356.1	16974	12	1373.2
16908	12	1339.9	16941	12	1356.6	16975	12	1373.8
16909	12	1340.4	16942	12	1357.1	16976	12	1374.3
			16943	12	1357.6	16977	12	1374.8
16910	12	1340.9	16944	12	1358.1	16978	12	1375.3
16911	12	1341.4	16945	12	1358.6	16979	12	1375.8
16912	12	1341.9	16946	12	1359.1			
16913	12	1342.4	16947	12	1359.6	16980	12	1376.3
16914	12	1342.9	16948	12	1360.1	16981	12	1376.8
16915	12	1343.4	16949	12	1360.6	16982	12	1377.3
16916	12	1343.9				16983	12	1377.8
16917	12	1344.4	16950	12	1361.1	16984	12	1378.3
16918	12	1345.0	16951	12	1361.6	16985	12	1378.8
16919	12	1345.5	16952	12	1362.1	16986	12	1379.3
			16953	12	1362.6	16987	12	1379.8
16920	12	1346.0	16954	12	1363.1	16988	12	1380.3
16921	12	1346.5	16955	12	1363.6	16989	12	1380.8
16922	12	1347.0	16956	12	1364.2			
16923	12	1347.5	16957	12	1364.7	16990	12	1381.3
16924	12	1348.0	16958	12	1365.2	16991	12	1381.8
16925	12	1348.5	16959	12	1365.7	16992	12	1382.3
16926	12	1349.0				16993	12	1382.8
16927	12	1349.5	16960	12	1366.2	16994	12	1383.4
16928	12	1350.0	16961	12	1366.7	16995	12	1383.9
16929	12	1350.5	16962	12	1367.2	16996	12	1384.4
			16963	12	1367.7	16997	12	1384.9
16930	12	1351.0	16964	12	1368.2	16998	12	1385.4
16931	12	1351.5	16965	12	1368.7	16999	12	1385.9
16932	12	1352.0	16966	12	1369.2			
16933	12	1352.5	16967	12	1369.7	17000	12	1386.4

Use check point at 16800 Kc

Frequency: 17000-17100 Kc

Freq.	A	B	Freq.	A	B	Freq.	A	B
17000	12	1386.4	17034	12	1403.6	17068	12	1420.8
17001	12	1386.9	17035	12	1404.1	17069	12	1421.3
17002	12	1387.4	17036	12	1404.6			
17003	12	1387.9	17037	12	1405.1	17070	12	1421.8
17004	12	1388.4	17038	12	1405.6	17071	12	1422.3
17005	12	1388.9	17039	12	1406.1	17072	12	1422.8
17006	12	1389.4				17073	12	1423.4
17007	12	1389.9	17040	12	1406.6	17074	12	1423.9
17008	12	1390.4	17041	12	1407.1	17075	12	1424.4
17009	12	1390.9	17042	12	1407.6	17076	12	1424.9
			17043	12	1408.1	17077	12	1425.4
17010	12	1391.4	17044	12	1408.6	17078	12	1425.9
17011	12	1391.9	17045	12	1409.1	17079	12	1426.4
17012	12	1392.5	17046	12	1409.6			
17013	12	1393.0	17047	12	1410.2	17080	12	1426.9
17014	12	1393.5	17048	12	1410.7	17081	12	1427.4
17015	12	1394.0	17049	12	1411.2	17082	12	1427.9
17016	12	1394.5				17083	12	1428.4
17017	12	1395.0	17050	12	1411.7	17084	12	1428.9
17018	12	1395.5	17051	12	1412.2	17085	12	1429.4
17019	12	1396.0	17052	12	1412.7	17086	12	1430.0
			17053	12	1413.2	17087	12	1430.5
17020	12	1396.5	17054	12	1413.7	17088	12	1431.0
17021	12	1397.0	17055	12	1414.2	17089	12	1431.5
17022	12	1397.5	17056	12	1414.7			
17023	12	1398.0	17057	12	1415.2	17090	12	1432.0
17024	12	1398.5	17058	12	1415.7	17091	12	1432.5
17025	12	1399.0	17059	12	1416.2	17092	12	1433.0
17026	12	1399.5				17093	12	1433.5
17027	12	1400.0	17060	12	1416.8	17094	12	1434.0
17028	12	1400.5	17061	12	1417.3	17095	12	1434.5
17029	12	1401.0	17062	12	1417.8	17096	12	1435.0
			17063	12	1418.3	17097	12	1435.5
17030	12	1401.5	17064	12	1418.8	17098	12	1436.0
17031	12	1402.1	17065	12	1419.3	17099	12	1436.6
17032	12	1402.6	17066	12	1419.8			
17033	12	1403.1	17067	12	1420.3	17100	12	1437.1

Use check point at 16800 Kc

Frequency: 17100-17200 Kc

Freq.	A	B	Freq.	A	B	Freq.	A	B
17100	12	1437.1	17134	12	1454.4	17168	12	1471.7
17101	12	1437.6	17135	12	1454.9	17169	12	1472.2
17102	12	1438.1	17136	12	1455.4			
17103	12	1438.6	17137	12	1455.9	17170	12	1472.7
17104	12	1439.1	17138	12	1456.4	17171	12	1473.2
17105	12	1439.6	17139	12	1456.9	17172	12	1473.7
17106	12	1440.1				17173	12	1474.2
17107	12	1440.6	17140	12	1457.4	17174	12	1474.7
17108	12	1441.1	17141	12	1458.0	17175	12	1475.2
17109	12	1441.6	17142	12	1458.5	17176	12	1475.7
			17143	12	1459.0	17177	12	1476.2
17110	12	1442.2	17144	12	1459.5	17178	12	1476.8
17111	12	1442.7	17145	12	1460.0	17179	12	1477.3
17112	12	1443.2	17146	12	1460.5			
17113	12	1443.7	17147	12	1461.0	17180	12	1477.8
17114	12	1444.2	17148	12	1461.5	17181	12	1478.3
17115	12	1444.7	17149	12	1462.0	17182	12	1478.8
17116	12	1445.2				17183	12	1479.3
17117	12	1445.7	17150	12	1462.5	17184	12	1479.8
17118	12	1446.2	17151	12	1463.1	17185	12	1480.3
17119	12	1446.7	17152	12	1463.6	17186	12	1480.8
			17153	12	1464.1	17187	12	1481.3
17120	12	1447.3	17154	12	1464.6	17188	12	1481.8
17121	12	1447.8	17155	12	1465.1	17189	12	1482.3
17122	12	1448.3	17156					

**TABLE 6-10. CALIBRATION OF HIGH FREQUENCY OSCILLATOR
2000KC TO 18100KC**

Frequency: 17200-17300 Kc

Freq.	A	B	Freq.	A	B	Freq.	A	B
17200	12	1487.9	17234	12	1505.2	17268	12	1522.5
17201	12	1488.4	17235	12	1505.7	17269	12	1523.1
17202	12	1488.9	17236	12	1506.2			
17203	12	1489.4	17237	12	1506.7	17270	12	1523.6
17204	12	1489.9	17238	12	1507.2	17271	12	1524.1
17205	12	1490.4	17239	12	1507.7	17272	12	1524.6
17206	12	1490.9				17273	12	1525.1
17207	12	1491.4	17240	12	1508.2	17274	12	1525.6
17208	12	1491.9	17241	12	1508.8	17275	12	1526.1
17209	12	1492.5	17242	12	1509.3	17276	12	1526.6
			17243	12	1509.8	17277	12	1527.1
17210	12	1493.0	17244	12	1510.3	17278	12	1527.7
17211	12	1493.5	17245	12	1510.8	17279	12	1528.2
17212	12	1494.0	17246	12	1511.3			
17213	12	1494.5	17247	12	1511.8	17280	12	1528.7
17214	12	1495.0	17248	12	1512.3	17281	12	1529.2
17215	12	1495.5	17249	12	1512.8	17282	12	1529.7
17216	12	1496.0				17283	12	1530.2
17217	12	1496.5	17250	12	1513.4	17284	12	1530.7
17218	12	1497.0	17251	12	1513.9	17285	12	1531.2
17219	12	1497.5	17252	12	1514.4	17286	12	1531.7
			17253	12	1514.9	17287	12	1532.3
17220	12	1498.0	17254	12	1515.4	17288	12	1532.8
17221	12	1498.5	17255	12	1515.9	17289	12	1533.3
17222	12	1499.0	17256	12	1516.4			
17223	12	1499.5	17257	12	1516.9	17290	12	1533.8
17224	12	1500.0	17258	12	1517.4	17291	12	1534.3
17225	12	1500.6	17259	12	1517.9	17292	12	1534.8
17226	12	1501.1				17293	12	1535.3
17227	12	1501.6	17260	12	1518.5	17294	12	1535.8
17228	12	1502.1	17261	12	1519.0	17295	12	1536.3
17229	12	1502.6	17262	12	1519.5	17296	12	1536.8
			17263	12	1520.0	17297	12	1537.4
17230	12	1503.1	17264	12	1520.5	17298	12	1537.9
17231	12	1503.6	17265	12	1521.0	17299	12	1538.4
17232	12	1504.2	17266	12	1521.5			
17233	12	1504.7	17267	12	1522.0	17300	12	1538.9

Use check point at 17400 Kc

Frequency: 17400-17500 Kc

Freq.	A	B	Freq.	A	B	Freq.	A	B
17400	12	1590.1	17434	12	1607.6	17468	12	1625.2
17401	12	1590.6	17435	12	1608.2	17469	12	1625.7
17402	12	1591.1	17436	12	1608.7			
17403	12	1591.6	17437	12	1609.2	17470	12	1626.3
17404	12	1592.1	17438	12	1609.7	17471	12	1626.8
17405	12	1592.7	17439	12	1610.2	17472	12	1627.3
17406	12	1593.2				17473	12	1627.8
17407	12	1593.7	17440	12	1610.7	17474	12	1628.3
17408	12	1594.2	17441	12	1611.2	17475	12	1628.9
17409	12	1594.7	17442	12	1611.8	17476	12	1629.4
			17443	12	1612.3	17477	12	1629.9
17410	12	1595.2	17444	12	1612.8	17478	12	1630.4
17411	12	1595.8	17445	12	1613.3	17479	12	1630.9
17412	12	1596.3	17446	12	1613.8			
17413	12	1596.8	17447	12	1614.3	17480	12	1631.5
17414	12	1597.3	17448	12	1614.9	17481	12	1632.0
17415	12	1597.8	17449	12	1615.4	17482	12	1632.5
17416	12	1598.3				17483	12	1633.0
17417	12	1598.9	17450	12	1615.9	17484	12	1633.5
17418	12	1599.4	17451	12	1616.4	17485	12	1634.1
17419	12	1599.9	17452	12	1616.9	17486	12	1634.6
			17453	12	1617.4	17487	12	1635.1
17420	12	1600.4	17454	12	1618.0	17488	12	1635.6
17421	12	1600.9	17455	12	1618.5	17489	12	1636.1
17422	12	1601.4	17456	12	1619.0			
17423	12	1602.0	17457	12	1619.5	17490	12	1636.7
17424	12	1602.5	17458	12	1620.0	17491	12	1637.2
17425	12	1603.0	17459	12	1620.5	17492	12	1637.7
17426	12	1603.5				17493	12	1638.2
17427	12	1604.0	17460	12	1621.1	17494	12	1638.7
17428	12	1604.5	17461	12	1621.6	17495	12	1639.3
17429	12	1605.1	17462	12	1622.1	17496	12	1639.8
			17463	12	1622.6	17497	12	1640.3
17430	12	1605.6	17464	12	1623.1	17498	12	1640.8
17431	12	1606.1	17465	12	1623.7	17499	12	1641.3
17432	12	1606.6	17466	12	1624.2			
17433	12	1607.1	17467	12	1624.7	17500	12	1641.9

Use check point at 17400 Kc

Frequency: 17300-17400 Kc

Freq.	A	B	Freq.	A	B	Freq.	A	B
17300	12	1538.9	17334	12	1556.2	17368	12	1573.7
17301	12	1539.4	17335	12	1556.7	17369	12	1574.2
17302	12	1539.9	17336	12	1557.2			
17303	12	1540.4	17337	12	1557.8	17370	12	1574.7
17304	12	1540.9	17338	12	1558.3	17371	12	1575.2
17305	12	1541.4	17339	12	1558.8	17372	12	1575.7
17306	12	1541.9				17373	12	1576.2
17307	12	1542.5	17340	12	1559.3	17374	12	1576.7
17308	12	1543.0	17341	12	1559.8	17375	12	1577.2
17309	12	1543.5	17342	12	1560.3	17376	12	1577.8
			17343	12	1560.8	17377	12	1578.3
17310	12	1544.0	17344	12	1561.3	17378	12	1578.8
17311	12	1544.5	17345	12	1561.8	17379	12	1579.3
17312	12	1545.0	17346	12	1562.4			
17313	12	1545.5	17347	12	1562.9	17380	12	1579.8
17314	12	1546.0	17348	12	1563.4	17381	12	1580.3
17315	12	1546.5	17349	12	1563.9	17382	12	1580.8
17316	12	1547.0				17383	12	1581.4
17317	12	1547.6	17350	12	1564.4	17384	12	1581.9
17318	12	1548.1	17351	12	1564.9	17385	12	1582.4
17319	12	1548.6	17352	12	1565.4	17386	12	1582.9
			17353	12	1566.0	17387	12	1583.4
17320	12	1549.1	17354	12	1566.5	17388	12	1583.9
17321	12	1549.6	17355	12	1567.0	17389	12	1584.4
17322	12	1550.1	17356	12	1567.5			
17323	12	1550.6	17357	12	1568.0	17390	12	1584.9
17324	12	1551.1	17358	12	1568.5	17391	12	1585.5
17325	12	1551.6	17359	12	1569.0	17392	12	1586.0
17326	12	1552.1				17393	12	1586.5
17327	12	1552.7	17360	12	1569.5	17394	12	1587.0
17328	12	1553.2	17361	12	1570.1	17395	12	1587.5
17329	12	1553.7	17362	12	1570.6	17396	12	1588.0
			17363	12	1571.1	17397	12	1588.5
17330	12	1554.2	17364	12	1571.6	17398	12	1589.1
17331	12	1554.7	17365	12	1572.1	17399	12	1589.6
17332	12	1555.2	17366	12	1572.6			
17333	12	1555.7	17367	12	1573.1	17400	12	1590.1

Use check point at 17400 Kc

Frequency: 17500-17600 Kc

Freq.	A	B	Freq.	A	B	Freq.	A	B
17500	12	1641.9	17534	12	1659.6	17568	12	1677.3
17501	12	1642.4	17535	12	1660.1	17569	12	1677.8
17502	12	1642.9	17536	12	1660.6			
17503	12	1643.4	17537	12	1661.1	17570	12	1678.3
17504	12	1643.9	17538	12	1661.7	17571	12	1678.9
17505	12	1644.5	17539	12	1662.2	17572	12	1679.4
17506	12	1645.0				17573	12	1679.9
17507	12	1645.5	17540	12	1662.7	17574	12	1680.4
17508	12	1646.0	17541	12	1663.2	17575	12	1681.0
17509	12	1646.5	17542	12	1663.7	17576	12	1681.5
			17543	12	1664.3	17577	12	1682.0
17510	12	1647.1	17544	12	1664.8	17578	12	1682.5
17511	12	1647.6	17545	12	1665.3	17579	12	1683.0
17512	12	1648.1	17546	12	1665.8			
17513	12	1648.6	17547	12	1666.3	17580	12	1683.6
17514	12	1649.1	17548	12	1666.9	17581	12	1684.1
17515	12	1649.7	17549	12	1667.4	17582	12	1684.6
17516	12	1650.2				17583	12	1685.1
17517	12	1650.7	17550	12	1667.9	17584	12	1685.7
17518	12	1651.2	17551	12	1668.4	17585	12	1686.2
17519	12	1651.7	17552	12	1669.0	17586	12	1686.7
			17553	12	1669.5	17587	12	1687.2
17520	12	1652.3	17554	12	1670.0	17588	12	1687.8
17521	12	1652.8	17555	12	1670.5	17589	12	1688.3
17522	12	1653.3	17556					

**TABLE 6-10. CALIBRATION OF HIGH FREQUENCY OSCILLATOR
200KC TO 18100KC**

Frequency: 17600—17700 Kc

Freq.	A	B	Freq.	A	B	Freq.	A	B
17600	12	1694.1	17634	12	1712.0	17668	12	1729.9
17601	12	1694.6	17635	12	1712.5	17669	12	1730.4
17602	12	1695.1	17636	12	1713.0			
17603	12	1695.7	17637	12	1713.5	17670	12	1731.0
17604	12	1696.2	17638	12	1714.1	17671	12	1731.5
17605	12	1696.7	17639	12	1714.6	17672	12	1732.0
17606	12	1697.2				17673	12	1732.5
17607	12	1697.8	17640	12	1715.1	17674	12	1733.1
17608	12	1698.3	17641	12	1715.6	17675	12	1733.6
17609	12	1698.8	17642	12	1716.2	17676	12	1734.1
			17643	12	1716.7	17677	12	1734.7
17610	12	1699.3	17644	12	1717.2	17678	12	1735.2
17611	12	1699.9	17645	12	1717.8	17679	12	1735.7
17612	12	1700.4	17646	12	1718.3			
17613	12	1700.9	17647	12	1718.8	17680	12	1736.2
17614	12	1701.4	17648	12	1719.3	17681	12	1736.8
17615	12	1702.0	17649	12	1719.9	17682	12	1737.3
17616	12	1702.5				17683	12	1737.8
17617	12	1703.0	17650	12	1720.4	17684	12	1738.4
17618	12	1703.5	17651	12	1720.9	17685	12	1738.9
17619	12	1704.1	17652	12	1721.5	17686	12	1739.4
			17653	12	1722.0	17687	12	1739.9
17620	12	1704.6	17654	12	1722.5	17688	12	1740.5
17621	12	1705.1	17655	12	1723.0	17689	12	1741.0
17622	12	1705.7	17656	12	1723.6			
17623	12	1706.2	17657	12	1724.1	17690	12	1741.5
17624	12	1706.7	17658	12	1724.6	17691	12	1742.0
17625	12	1707.2	17659	12	1725.2	17692	12	1742.6
17626	12	1707.8				17693	12	1743.1
17627	12	1708.3	17660	12	1725.7	17694	12	1743.6
17628	12	1708.8	17661	12	1726.2	17695	12	1744.1
17629	12	1709.3	17662	12	1726.7	17696	12	1744.4
			17663	12	1727.3	17697	12	1745.2
17630	12	1709.9	17664	12	1727.8	17698	12	1745.7
17631	12	1710.4	17665	12	1728.3	17699	12	1746.3
17632	12	1710.9	17666	12	1728.8			
17633	12	1711.4	17667	12	1729.4	17700	12	1746.8

Use check point at 17400 Kc

Frequency: 17800—17900 Kc

Freq.	A	B	Freq.	A	B	Freq.	A	B
17800	12	1800.4	17834	12	1818.8	17868	12	1837.2
17801	12	1801.0	17835	12	1819.3	17869	12	1837.7
17802	12	1801.5	17836	12	1819.8			
17803	12	1802.0	17837	12	1820.4	17870	12	1838.3
17804	12	1802.6	17838	12	1820.9	17871	12	1838.8
17805	12	1803.1	17839	12	1821.5	17872	12	1839.3
17806	12	1803.6				17873	12	1839.9
17807	12	1804.2	17840	12	1822.0	17874	12	1840.4
17808	12	1804.7	17841	12	1822.6	17875	12	1841.0
17809	12	1805.3	17842	12	1823.1	17876	12	1841.5
			17843	12	1823.6	17877	12	1842.1
17810	12	1805.8	17844	12	1824.2	17878	12	1842.6
17811	12	1806.3	17845	12	1824.7	17879	12	1843.1
17812	12	1806.9	17846	12	1825.3			
17813	12	1807.4	17847	12	1825.8	17880	12	1843.7
17814	12	1808.0	17848	12	1826.3	17881	12	1844.2
17815	12	1808.5	17849	12	1826.9	17882	12	1844.8
17816	12	1809.0				17883	12	1845.3
17817	12	1809.6	17850	12	1827.4	17884	12	1845.9
17818	12	1810.1	17851	12	1828.0	17885	12	1846.4
17819	12	1810.6	17852	12	1828.5	17886	12	1847.0
			17853	12	1829.1	17887	12	1847.5
17820	12	1811.2	17854	12	1829.6	17888	12	1848.1
17821	12	1811.7	17855	12	1830.1	17889	12	1848.6
17822	12	1812.3	17856	12	1830.7			
17823	12	1812.8	17857	12	1831.2	17890	12	1849.2
17824	12	1813.3	17858	12	1831.8	17891	12	1849.7
17825	12	1813.9	17859	12	1832.3	17892	12	1850.3
17826	12	1814.4				17893	12	1850.8
17827	12	1815.0	17860	12	1832.8	17894	12	1851.4
17828	12	1815.5	17861	12	1833.4	17895	12	1852.0
17829	12	1816.1	17862	12	1833.9	17896	12	1852.5
			17863	12	1834.5	17897	12	1853.1
17830	12	1816.6	17864	12	1835.0	17898	12	1853.6
17831	12	1817.1	17865	12	1835.6	17899	12	1854.2
17832	12	1817.7	17866	12	1836.1			
17833	12	1818.2	17867	12	1836.6	17900	12	1854.7

Use check point at 18000 Kc

Frequency: 17700—17800 Kc

Freq.	A	B	Freq.	A	B	Freq.	A	B
17700	12	1746.8	17734	12	1765.0	17768	12	1783.2
17701	12	1747.3	17735	12	1765.5	17769	12	1783.7
17702	12	1747.9	17736	12	1766.0			
17703	12	1748.4	17737	12	1766.6	17770	12	1784.3
17704	12	1748.9	17738	12	1767.1	17771	12	1784.8
17705	12	1749.5	17739	12	1767.7	17772	12	1785.3
17706	12	1750.0				17773	12	1785.9
17707	12	1750.5	17740	12	1768.2	17774	12	1786.4
17708	12	1751.1	17741	12	1768.7	17775	12	1787.0
17709	12	1751.6	17742	12	1769.3	17776	12	1787.5
			17743	12	1769.8	17777	12	1788.0
17710	12	1752.1	17744	12	1770.3	17778	12	1788.6
17711	12	1752.7	17745	12	1770.9	17779	12	1789.1
17712	12	1753.2	17746	12	1771.4			
17713	12	1753.8	17747	12	1771.9	17780	12	1789.6
17714	12	1754.3	17748	12	1772.5	17781	12	1790.2
17715	12	1754.8	17749	12	1773.0	17782	12	1790.7
17716	12	1755.4				17783	12	1791.3
17717	12	1755.9	17750	12	1773.5	17784	12	1791.8
17718	12	1756.4	17751	12	1774.1	17785	12	1792.3
17719	12	1757.0	17752	12	1774.6	17786	12	1792.9
			17753	12	1775.1	17787	12	1793.4
17720	12	1757.5	17754	12	1775.7	17788	12	1794.0
17721	12	1758.0	17755	12	1776.2	17789	12	1794.5
17722	12	1758.6	17756	12	1776.7			
17723	12	1759.1	17757	12	1777.3	17790	12	1795.0
17724	12	1759.6	17758	12	1777.8	17791	12	1795.6
17725	12	1760.2	17759	12	1778.3	17792	12	1796.1
17726	12	1760.7				17793	12	1796.6
17727	12	1761.2	17760	12	1778.9	17794	12	1797.2
17728	12	1761.8	17761	12	1779.4	17795	12	1797.7
17729	12	1762.3	17762	12	1780.0	17796	12	1798.3
			17763	12	1780.5	17797	12	1798.8
17730	12	1762.8	17764	12	1781.0	17798	12	1799.3
17731	12	1763.4	17765	12	1781.6	17799	12	1799.9
17732	12	1763.9	17766	12	1782.1			
17733	12	1764.4	17767	12	1782.6	17800	12	1800.4

Use check point at 18000 Kc

Frequency: 17900—18000 Kc

Freq.	A	B	Freq.	A	B	Freq.	A	B
17900	12	1854.7	17934	12	1873.5	17968	12	1892.3
17901	12	1855.3	17935	12	1874.0	17969	12	1892.8
17902	12	1855.8	17936	12	1874.6			
17903	12	1856.4	17937	12	1875.1	17970	12	1893.4
17904	12	1856.9	17938	12	1875.7	17971	12	1893.9
17905	12	1857.5	17939	12	1876.2	17972	12	1894.5
17906	12	1858.0				17973	12	1895.0
17907	12	1858.6	17940	12	1876.8	17974	12	1895.6
17908	12	1859.1	17941	12	1877.3	17975	12	1896.2
17909	12	1859.7	17942	12	1877.9	17976	12	1896.7
			17943	12	1878.4	17977	12	1897.3
17910	12	1860.2	17944	12	1879.0	17978	12	1897.8
17911	12	1860.8	17945	12	1879.5	17979	12	1898.4
17912	12	1861.3	17946	12	1880.1			
17913	12	1861.9	17947	12	1880.6	17980	12	1898.9
17914	12	1862.4	17948	12	1881.2	17981	12	1899.5
17915	12	1863.0	17949	12	1881.7	17982	12	1900.0
17916	12	1863.5				17983	12	1900.6
17917	12	1864.1	17950	12	1882.3	17984	12	1901.1
17918	12	1864.6	17951	12	1882.9	17985	12	1901.7
17919	12	1865.2	17952	12	1883.4	17986	12	1902.2
			17953	12	1884.0	17987	12	1902.8
17920	12	1865.7	17954	12	1884.5	17988	12	1903.4
17921	12	1866.3	17955	12	1885.1	17989	12	1903.9
17922	12	1866.8	17956					

**TABLE 6-10. CALIBRATION OF HIGH FREQUENCY OSCILLATOR
2000KC TO 18100KC**

<i>Freq.</i>	<i>A</i>	<i>B</i>	<i>Freq.</i>	<i>A</i>	<i>B</i>	<i>Freq.</i>	<i>A</i>	<i>B</i>
18000	12	1910.0	18034	12	1929.1	18068	12	1948.3
18001	12	1910.6	18035	12	1929.7	18069	12	1948.8
18002	12	1911.1	18036	12	1930.2			
18003	12	1911.7	18037	12	1930.8	18070	12	1949.4
18004	12	1912.2	18038	12	1931.4	18071	12	1950.0
18005	12	1912.8	18039	12	1931.9	18072	12	1950.5
18006	12	1913.4				18073	12	1951.1
18007	12	1913.9	18040	12	1932.5	18074	12	1951.7
18008	12	1914.5	18041	12	1933.0	18075	12	1952.3
18009	12	1915.1	18042	12	1933.6	18076	12	1952.8
			18043	12	1934.2	18077	12	1953.4
18010	12	1915.6	18044	12	1934.7	18078	12	1954.0
18011	12	1916.2	18045	12	1935.3	18079	12	1954.5
18012	12	1916.7	18046	12	1935.9			
18013	12	1917.3	18047	12	1936.4	18080	12	1955.1
18014	12	1917.9	18048	12	1937.0	18081	12	1955.7
18015	12	1918.4	18049	12	1937.5	18082	12	1956.2
18016	12	1919.0				18083	12	1956.8
18017	12	1919.6	18050	12	1938.1	18084	12	1957.4
18018	12	1920.1	18051	12	1938.7	18085	12	1957.9
18019	12	1920.7	18052	12	1939.2	18086	12	1958.5
			18053	12	1939.8	18087	12	1959.1
18020	12	1921.2	18054	12	1940.3	18088	12	1959.7
18021	12	1921.8	18055	12	1940.9	18089	12	1960.2
18022	12	1922.4	18056	12	1941.5			
18023	12	1922.9	18057	12	1942.0	18090	12	1960.8
18024	12	1923.5	18058	12	1942.6	18091	12	1961.4
18025	12	1924.1	18059	12	1943.2	18092	12	1961.9
18026	12	1924.6				18093	12	1962.5
18027	12	1925.2	18060	12	1943.7	18094	12	1963.1
18028	12	1925.7	18061	12	1944.3	18095	12	1963.6
18029	12	1926.3	18062	12	1944.9	18096	12	1964.2
			18063	12	1945.4	18097	12	1964.8
18030	12	1926.9	18064	12	1946.0	18098	12	1965.3
18031	12	1927.4	18065	12	1946.6	18099	12	1965.9
18032	12	1928.0	18066	12	1947.1			
18033	12	1928.5	18067	12	1947.7	18100	12	1966.5

Use check point at 18000 Kc

**TABLE 6-11. TABLES OF APPROXIMATE DIAL SETTINGS
(FOR ANTENNA TUNING AND LOADING)**

20 Ft. Antenna <i>Airplane and Antenna</i>				22.5 Ft. Antenna <i>Airplane and Antenna</i>			
<i>Antenna Loading Unit</i>				<i>Antenna Loading Unit</i>			
KC	P	Q		KC	P	Q	
210	1	1		208	1	1	
250	2	2		250	2	2	
300	3	2		300	3	2	
400	4	3		400	4	3	
500	5	1		500	5	1	
600	5	2		600	5	2	
<i>Transmitter</i>				<i>Transmitter</i>			
KC	C	D	E	KC	C	D	E
3000	1-2	...	70	2800	1-2	...	70
3500	2-3	...	115	3000	1-2	...	70
4000	3-4	...	130	3500	2-3	...	120
5000	4-5	70	150	4000	3-4	...	130
6000	5-6	45	170	5000	4-5	90	150
8000	6-7	30	185	6000	5-6	60	160
10000	7	75	190	8000	6-7	40	185
11000	7	90	200	10000	7	80	200
11300	7	100	200	10500	11	77	200
11500	11	85	200	11000	11	64	66
12000	11	75	30	12000	11	65	150
13000	11	75	140	13000	11	68	165
14000	11	80	164	14000	11	75	180
15000	11	85	170	15000	11	80	180
16000	12	75	190	16000	12	75	200
18000	12	85	200	17000	13	60	175
				18000	13	65	185

This Table for Use Without Shunt Capacitor

30 Ft. Antenna <i>Airplane and Antenna</i>				32.5 Ft. Antenna <i>Airplane and Antenna</i>			
<i>Antenna Loading Unit</i>				<i>Antenna Loading Unit</i>			
KC	P	Q		KC	P	Q	
200	1	1		200	1	1	
250	2	3		250	2	3	
300	3	4		300	3	4	
400	4	4		400	5	1	
500	5	1		500	5	2	
600	5	2		600	5	2	
<i>Transmitter</i>				<i>Transmitter</i>			
KC	C	D	E	KC	C	D	E
2500	1-2	...	20	2450	1-2	...	26
3000	3-4	...	70	3000	3	...	65
3500	4	...	95	3500	4-5	...	100
4000	4-5	...	120	4000	5	...	120
5000	5-6	...	145	5000	5-6	...	150
6000	6-7	...	165	6000	6-7	...	165
8000	7	95	180	8000	7	100	200
8500	7	100	200	9000	10	42	160
9000	10	48	130	10000	10	46	185
10000	10	50	170	11000	10	54	200
11000	10	55	200	12000	10	65	200
12000	10	63	200	13000	10	75	200
14000	10	82	200	14000	10	82	200
15000	10	92	200	14600	10	88	200
15600	10	98	200	16000	11	100	188
16000	11	90	200	16200	11	100	200
16600	11	98	200	16500	13	69	160
17000	13	45	188	17000	13	70	170
18000	13	70	188	18000	13	75	180

This Table for Use Without Shunt Capacitor

25 Ft. Antenna <i>Airplane and Antenna</i>				27.5 Ft. Antenna <i>Airplane and Antenna</i>			
<i>Antenna Loading Unit</i>				<i>Antenna Loading Unit</i>			
KC	P	Q		KC	P	Q	
207	1	1		204	1	1	
250	2	2		250	2	2	
300	3	3		300	3	3	
400	4	4		400	4	4	
500	5	1		500	5	1	
600	5	2		600	5	2	
<i>Transmitter</i>				<i>Transmitter</i>			
KC	C	D	E	KC	C	D	E
2700	1-2	...	10	2600	1	...	0
3000	2-3	...	60	3000	2	...	75
3500	3-4	...	100	3500	3-4	...	110
4000	4-5	...	125	4000	4-5	...	130
5000	5-6	...	150	5000	6	...	150
6000	6	80	160	6000	6-7	...	165
8000	6-7	70	180	8000	7	70	190
9800	7	100	200	9100	7	100	200
10000	10	65	55	9500	10	57	80
11000	10	65	150	10000	10	55	110
12000	10	70	170	11000	10	60	175
14000	10	85	180	12000	10	65	185
15000	10	95	190	14000	10	80	195
16000	11	95	200	15500	10	100	195
17000	13	35	190	16500	11	95	200
18000	13	55	195	17000	13	45	190
				18000	13	60	195

This Table for Use Without Shunt Capacitor

35 Ft. Antenna <i>Airplane and Antenna</i>				40 Ft. Antenna <i>Airplane and Antenna</i>			
<i>Antenna Loading Unit</i>				<i>Antenna Loading Unit</i>			
KC	P	Q		KC	P	Q	
200	1	1		200	1	2	
250	2	4		250	3	1	
300	3	4		300	4	1	
400	5	1		400	5	1	
500	5	2		500	5	2	
600	5	3		600	5	3	
<i>Transmitter</i>				<i>Transmitter</i>			
KC	C	D	E	KC	C	D	E
2400	1-2	...	0	2300	1-2	...	3
3000	3-4	...	70	2500	2-3	...	10
3500	4-5	...	100	3000	3-4	...	60
4000	5-6	...	120	3500	4-5	...	95
5000	6-7	...	145	4000	5-6	...	120
6000	7	...	160	5000	6-7	...	150
7000	7	...	180	6000	7	...	170
7600	7	100	200	6800	7	100	200
8000	8	75	40	7000	8	60	50
9000	8	85	62	8000	8	70	121
10000	8	100	100	9000	8	83	111
10400	8	100	126	10000	8	97	121
11000	11	52	200	10500	8	100	140
12000	11	62	200	11000	10	60	200
14000	11	77	200	12000	10	70	200
15000	11	86	200	14000	10	88	200
15700	11	100	190	14500	10	100	200
16000	13	66	152	15000	12	76	200
17000	13	84	142	16000	12	84	200
18000	13	100	154	17000	12	100	141
				18000	12	100	146

This Table for Use Without Shunt Capacitor

**TABLE 6-11. TABLES OF APPROXIMATE DIAL SETTINGS
(FOR ANTENNA TUNING AND LOADING)**

45 Ft. Antenna Airplane and Antenna				50 Ft. Antenna Airplane and Antenna			
Antenna Loading Unit				Antenna Loading Unit			
KC	P	Q		KC	P	Q	
200	1	3		200	2	1	
250	3	2		250	3	2	
300	4	1		300	4	2	
400	5	1		400	5	1	
500	5	2		500	5	2	
600	5	3		600	5	3	
Transmitter				Transmitter			
KC	C	D	E	KC	C	D	E
2200	1-2	...	0	2100	1-2	...	0
2500	2-3	...	20	2500	3-4	...	19
3000	4-5	...	62	3000	4-5	...	55
3500	5-6	...	90	3500	5-6	...	95
4000	6	...	120	4000	6-7	...	120
5000	7	...	155	5000	7	...	160
6000	7	100	175	5500	7	100	180
6100	7	100	185	6000	8	38	90
7000	8	59	106	7000	8	48	148
8000	8	69	129	8000	8	65	152
9000	8	85	106	9000	8	85	148
9800	8	100	90	10000	8	92	142
10000	10	53	200	11000	11	53	200
11000	10	64	200	12000	11	72	200
12000	10	73	200	13000	11	82	200
13000	10	83	200	14000	11	100	0
13740	10	100	182	15000	11	98	135
14000	12	70	200	16000	13	69	136
15000	12	82	92	17000	13	71	164
16000	12	85	125	18000	13	68	184
17000	12	87	164				
18000	12	86	195				

This Table for Use Without Shunt Capacitor

55 Ft. Antenna Airplane and Antenna				60 Ft. Antenna Airplane and Antenna			
Antenna Loading Unit				Antenna Loading Unit			
KC	P	Q		KC	P	Q	
200	2	1		200	2	2	
250	3	3		250	3	3	
300	4	2		300	4	2	
400	5	1		400	5	1	
500	5	2		500	5	2	
600	5	3		600	5	3	
Transmitter				Transmitter			
KC	C	D	E	KC	C	D	E
2000	1-2	...	0	2000	1-2	...	0
2500	3-4	...	15	2500	3-4	...	15
3000	4-5	...	45	3000	5-6	...	55
3500	5-6	...	100	3500	6-7	...	90
4000	6-7	...	130	4000	7	...	125
5000	7	100	168	4800	7	100	178
5170	7	100	181	5000	8	4	60
6000	8	35	126	6000	8	22	155
7000	8	51	152	7000	8	44	170
8000	8	64	160	8000	8	63	164
9000	8	81	136	9000	8	80	150
9700	8	100	106	9700	8	100	120
10000	9	68	195	10000	9	74	185
11000	9	87	171	10880	9	100	123
11500	9	100	165	11000	10	78	181
12000	10	90	161	11350	10	89	0
12200	10	100	82	12000	11	75	190
13000	12	62	133	13000	12	49	197
14000	12	63	183	15000	12	71	200
15000	12	68	200	17000	12	85	200
16000	13	45	169	18000	12	94	200
17000	13	62	177				
18000	13	72	185				

This Table for Use Without Shunt Capacitor

20 Ft. Antenna Airplane and Antenna				22.5 Ft. Antenna Airplane and Antenna			
Transmitter with Three Sections of Shunt Capacitor				Transmitter with Three Sections of Shunt Capacitor			
KC	C	D	E	KC	C	D	E
2100	1	...	0	2100	1	...	0
2500	3-4	...	30	2500	2-3	...	20
3000	4-5	...	30	3000	4-5	...	45
3500	5-6	...	52	3500	5-6	...	62
4000	6	...	65	4000	6	...	80
5000	6-7	...	102	5000	6-7	...	108
6000	7	50	118	6000	7	48	120
8000	7	72	146	7000	7	65	132
10300	7	90	168	8000	7	76	149
10500	7	100	174	10000	7	94	184
11000	10	94	200	10400	7	100	200
11300	10	100	200	10450	10	73	0
11600	11	75	0	11000	10	76	75
12000	11	75	80	12000	10	82	160
13000	11	80	142	13000	10	88	178
14000	11	86	180	14000	10	96	195
15000	11	92	200	14100	10	100	200
16000	13	66	185	14500	13	0	175
17000	13	84	190	15000	13	30	200
17700	13	100	200	16000	13	67	200
				17000	13	85	200
				17600	13	100	200

This Table for Use With Shunt Capacitor

25 Ft. Antenna Airplane and Antenna				27.5 Ft. Antenna Airplane and Antenna			
Transmitter with Three Sections of Shunt Capacitor				Transmitter with Three Sections of Shunt Capacitor			
KC	C	D	E	KC	C	D	E
2160	1-2	...	0	2130	1-2	...	0
2500	2-3	...	28	2500	2-3	...	20
3000	4-5	...	50	3000	4-5	...	44
3500	5-6	...	65	3500	5-6	...	65
4000	6-7	...	80	4000	6	...	85
5000	6-7	...	106	5000	6-7	...	116
6000	7	44	125	6000	7	52	138
7000	7	64	140	7000	7	65	154
9000	7	80	184	8000	7	75	174
9500	7	90	200	8800	7	86	200
10000	10	66	92	9000	10	59	40
11000	10	68	166	10000	10	62	156
12000	10	74	184	11000	10	63	191
13000	10	82	192	12000	10	75	200
14000	10	90	200	13000	10	84	200
14500	10	100	200	14000	10	92	200
15000	13	0	181	14400	10	100	200
16000	13	51	200	15000	11	94	200
17000	13	73	200	15600	11	100	200
18000	13	89	200	16000	13	56	200
				17000	13	76	200
				18000	13	90	200

This Table for Use With Shunt Capacitor

**TABLE 6-11. TABLES OF APPROXIMATE DIAL SETTINGS
(FOR ANTENNA TUNING AND LOADING)**

30 Ft. Antenna Airplane and Antenna				32.5 Ft. Antenna Airplane and Antenna			
Transmitter with Three Sections of Shunt Capacitor				Transmitter with Two Sections of Shunt Capacitor			
KC	C	D	E	KC	C	D	E
2100	1	...	0	2100	1-2	...	0
2500	2-3	...	30	2500	3-4	...	10
3000	4-5	...	48	3000	4-5	...	44
3500	5-6	...	64	3500	5-6	...	70
4000	6	...	80	4000	6-7	...	90
5000	6-7	...	121	5000	7	...	124
6000	7	54	138	6000	7	55	144
7000	7	71	152	7000	7	70	173
8000	7	81	186	7790	7	90	200
8350	7	100	200	8000	9	64	60
8500	10	50	88	9000	9	69	112
9000	10	52	138	10000	9	74	169
10000	10	55	165	11000	9	81	179
11000	10	66	200	12000	9	90	179
12000	10	76	200	12500	9	100	180
13000	10	85	200	13000	10	86	200
13500	10	89	200	14000	10	95	200
14000	10	93	200	14100	10	100	200
14500	11	89	200	15000	11	94	200
15000	11	93	200	15300	11	100	200
15500	13	41	200	16000	13	60	200
16000	13	58	200	17000	13	86	164
17000	13	76	200	18000	13	100	185
18000	13	91	200				

This Table for Use With Shunt Capacitor

45 Ft. Antenna Airplane and Antenna			
Transmitter with One Section of Shunt Capacitor			
KC	C	D	E
2050	1-2	...	0
2500	3-4	...	33
3000	4-5	...	70
3500	5-6	...	111
4000	6	...	132
5000	7	43	160
5500	7	54	180
5900	7	60	200
6000	9	30	42
7000	9	42	138
8000	9	55	158
9000	9	67	165
10000	9	74	170
11000	9	83	173
12000	9	100	150
12200	9	100	173
13000	11	80	200
14000	11	91	158
14400	11	100	110
15000	12	82	75
16000	12	85	143
17000	12	89	174
18000	12	92	200

This Table for Use With Shunt Capacitor

35 Ft. Antenna Airplane and Antenna				40 Ft. Antenna Airplane and Antenna			
Transmitter with Two Sections of Shunt Capacitor				Transmitter with Two Sections of Shunt Capacitor			
KC	C	D	E	KC	C	D	E
2150	1	...	0	2100	1-2	...	0
2500	2-3	...	22	2500	3-4	...	25
3000	4-5	...	60	3000	4-5	...	66
3500	5-6	...	85	3500	5-6	...	100
4000	6-7	...	110	4000	6-7	...	120
5000	7	32	128	5000	7	38	144
6000	7	56	156	6000	7	60	179
7000	7	75	184	6500	7	71	200
7435	7	95	200	7000	9	47	94
7500	9	58	49	8000	9	56	148
8000	9	60	112	9000	9	66	162
9000	9	67	142	10000	9	72	174
10000	9	72	160	11000	9	80	177
11000	9	80	176	12000	9	91	178
12000	9	88	178	12600	9	100	179
13000	9	100	181	13000	10	85	200
14000	10	90	200	14000	10	100	180
14600	10	100	200	14190	10	100	192
15000	13	0	178	14500	12	75	200
16000	13	70	156	15000	12	80	200
17000	13	90	130	16000	12	88	150
17700	13	100	146	17000	12	94	108
				18000	12	100	157

This Table for Use With Shunt Capacitor

200 Foot Trailing Antenna Any Type of Airplane		
Antenna Loading Unit		
KC	P	Q
200	3	3
250	4	2
300	5	1
400	5	2
500	5	3
600	5	3

There are no approximate settings for use with trailing antenna in high frequency range.

SECTION VII PARTS CATALOG

Introduction

Table of Parts

The parts listed in this table do not constitute a complete electrical and mechanical breakdown of the equipment. The table lists all electrical parts together with such operative mechanical parts as are subject to loss or failure, with the exception of structural and minor parts such as standard bolts, screws, nuts, and the like. In some instances, individual detail parts of a sub-assembly may not be listed as separate items, since replacement of such items is impractical.

Ordering of Spare Parts

Each Service using this list has established certain depots and service groups for the storage and issue of spare parts to its organizations requiring them. The regulations of each Service should be studied to determine the method and source for requisitioning spare parts. The information in this list, as to manufacturer's or contractor's name, type, model, or drawing number, is not to be interpreted as authorization to field agencies to attempt to purchase identical or comparable spare parts directly from the manufacturer or a wholesale or retail store except under emergency conditions as covered by existing regulations of the Service concerned.

U. S. Army Personnel: This table is for information *only* and is not to be used as a basis for requisitioning parts. Authorities for obtaining maintenance items are as follows: 1. For using organizations: applicable Service publications of the 00-30 series of AF Technical Orders. 2. For higher maintenance and supply echelons: applicable Service publications of the 16-55 series of AF Technical Orders.



RMA COLOR CODES

CAPACITORS (MMFD)

COLOR	NUMERAL	VOLTS	MULTIPLIER	TOLERANCE
BLACK	0		1	
BROWN	1	100	10	1%
RED	2	200	100	2%
ORANGE	3	300	1,000	3%
YELLOW	4	400	10,000	4%
GREEN	5	500	100,000	5%
BLUE	6	600	1,000,000	6%
VIOLET	7	700	10,000,000	7%
GRAY	8	800	100,000,000	8%
WHITE	9	900	1,000,000,000	9%
GOLD		1000	0.1	5%
SILVER		2000	0.01	10%
NO COLOR		500		20%

RESISTORS (OHMS)

COLOR	A 1st DIGIT	B 2nd DIGIT	C MULTIPLIER
SILVER			0.01
GOLD			0.1
BLACK		0	1.0
BROWN	1	1	10
RED	2	2	100
ORANGE	3	3	1,000
YELLOW	4	4	10,000
GREEN	5	5	100,000
BLUE	6	6	1,000,000
PURPLE	7	7	10,000,000
GRAY	8	8	100,000,000
WHITE	9	9	

D — TOLERANCE CODE:
 GOLD = 5% SILVER = 10% NO COLOR = 20%

OLD COLOR ARRANGEMENT

NEW COLOR ARRANGEMENT

BODY COLOR (NEW COLOR ARRANGEMENT ONLY) INDICATES TYPE OF RESISTOR, AS FOLLOWS:—
 BLACK — COMPOSITION, NON-INSULATED
 TAN, OLIVE OR WHITE — COMPOSITION, INSULATED
 DARK BROWN — WIRE-WOUND, INSULATED

INSTRUCTIONS FOR USE OF TABLE OF PARTS.

Each major unit is assigned a set of symbol numbers (101 to 199, 201 to 299), etc., so that on all drawings, or photographs and in all references in the text of the components of a major unit, the unit to which the component belongs will be instantly recognized because it belongs to a particular symbol number group. The symbol numbers assigned to the major units are as follows:

101 to 199 TRANSMITTER.

Transmitter as here designated as LESS C.F.I. unit, L.F.O. unit and Audio Amplifier.

- 201 to 299 Audio Amplifier.
- 601 to 699 Pilot's Control Unit.
- 1101 to 1199 Antenna Capacitor Unit.
- 2201 to 2299 C.F.I. Unit.
- 2501 to 2599 Antenna Loading Coil.
- 2601 to 2699 L.F.O. Unit.
- 2701 to 2799 Dynamotor Unit.

Each symbol number is prefixed by a letter to indicate the general classification of the part. A few of these classifications are as follows:

- C—Capacitors
- E—Miscellaneous electrical parts
- H—Hardware
- K—Relays
- L—Inductors
- R—Resistors
- T—Transformers

AS AN EXAMPLE—CM-201 is a capacitor used in the audio amplifier.

The last column contains the prime contractor's part number. The first listed number is that of Stewart-Warner Corporation and the following number that of General Electric Company.

DECIMAL EQUIVALENTS FOR WIRE GAGES

No. of Wire Gage	AWG (American)	SWG (British)	No. of Wire Gage	AWG (American)	SWG (British)
000000		.464	18	.040303	.048
00000		.432	19	.03589	.040
0000	.460	.400	20	.031961	.036
000	.40964	.372	21	.028462	.032
00	.3648	.348	22	.025347	.028
0	.32486	.324	23	.022571	.024
1	.2893	.300	24	.0201	.022
2	.25763	.276	25	.0179	.020
3	.22942	.252	26	.01594	.018
4	.20431	.232	27	.014195	.0164
5	.18194	.212	28	.012641	.0149
6	.16202	.192	29	.011257	.0136
7	.14428	.176	30	.010025	.0124
8	.12849	.160	31	.008928	.0116
9	.11443	.144	32	.00795	.0108
10	.10189	.128	33	.00708	.0100
11	.090742	.116	34	.006304	.0092
12	.080808	.104	35	.005614	.0084
13	.071961	.092	36	.005	.0076
14	.064084	.080	37	.004453	.0068
15	.057068	.072	38	.003965	.0060
16	.05082	.064	39	.003531	.0052
17	.045257	.056	40	.003144	.0048

TABLE OF PARTS

NOTE: Parts listed which are indicated by a # sign in column 2 are not available as spare parts and are listed for reference purposes only.

MODEL: RADIO TRANSMITTING SET AN/ART-13A MAJOR ASSEMBLY: RADIO TRANSMITTER T-47A/ART-13

Reference Symbol	Army Stock Number Navy Stock Number British Ref. Number	Name of Part and Description	Function	Mfr. and Desig. or Standard Type	Cont. or Govt. Dwg. or Spec. No.
B-101	3N3100A05-9	MOTOR: D.C.; 28 volt; 1/20 H.P. complete with brushes, brush caps and filter capacitors, reversible.	Autotune drive	Fractional Mtrs. F-803 Emerson Elec. D26BY-166-0212 Ohio Elec. Mfg. C-4732	Stewart-Warner 564666
C-101	2C6900-47A/11	CAPACITOR: Supplied as an assembly with C-102, C-103, C-104; ceramic; 185 microfarads $\pm 1\%$; 1000 volts D.C. test; 5/8" x 0.863" dia.; axial mounting hole tapped for No. 6-32 machine screw; two-solder lug terminals; terminal with min. capacity to mounting face marked by a red dot	1000-1200 Kc. band tank capacitor	Centralab 843-003	Stewart-Warner 564605
C-102	2C6900-47A/11	CAPACITOR: Supplied as an assembly with C-101, C-103, C-104; ceramic; 280 microfarads; in network with C-103 and C-104 total capacity 413 microfarads $\pm 1\%$.	1000-1200 Kc. band and 1200-1510 Kc. band tank capacitor	Centralab 843-003	Stewart-Warner 564605
C-103	2C6900-47A/11	CAPACITOR: Supplied as an assembly with C-101, C-102, C-104; ceramic; 200 microfarads; in network with C-102 and C-104 total capacity 413 microfarads $\pm 1\%$.	Same as C-102	Centralab 843-003	Stewart-Warner 564605
C-104	2C6900-47A/11	CAPACITOR: Supplied as an assembly with C-101, C-102, C-103; ceramic; 400 microfarads; in network with C-102 and C-103 total capacity 413 microfarads $\pm 1\%$.	Same as C-102	Centralab 843-003	Stewart-Warner 564605
C-105	3DA5-74.2	CAPACITOR: Fixed; mica; 5000 microfarads $\pm 5\%$; 1200 volts DCW; 1-5/8" x 1-1/8" x 23/64"; two mounting holes 0.144" dia., 1.312" between mtg/c; two solder lug terminals each with a 0.180" dia. hole.	V-101 cathode by-pass capacitor	Sprague Elec. M 1690, M 1689 Sangamo Elec. HLW-2250-5 Cornell-Dubilier 4LST	Stewart-Warner 564608
C-106	3DA6-39.1	CAPACITOR: Fixed; mica; 6000 microfarads $\pm 20\%$; 600 volts DCW; 1-5/8" x 1-1/8" x 23/64"; two mounting holes 0.144" dia., 1.312" between mtg/c; two solder lug terminals each with a 0.180" dia. hole.	V-101 filament by-pass capacitor	Sangamo Elec. HLS-1260-B20 Sprague Elec. M-1692 Cornell-Dubilier 4LS-12060	Stewart-Warner 564606
C-107	3DA2-34.3	CAPACITOR: Fixed; mica; 2000 microfarads $\pm 20\%$; 1200 volts DCW; 1-5/8" x 1-1/8" x 23/64"; two mounting holes 0.144" dia., 1.312" between mtg/c; two solder lug terminals each with a 0.180" dia. hole.	V-101 screen grid by-pass capacitor	JAN Type CM458202M	
C-108	3D9500-32	CAPACITOR: Fixed; mica; 500 microfarads $\pm 10\%$; 750 volts DCW; two solder lug terminals each with a 0.147" dia. hole, 1-3/4" between mtg/c; two 0.200" x 0.144" mounting holes, 23/32" between mtg/c.	V-102 grid coupling capacitor	Sangamo Elec. BEW-15350-B10	Stewart-Warner 564525

TABLE OF PARTS (Cont'd)

NOTE: Parts listed which are indicated by a # sign in column 2 are not available as spare parts and are listed for reference purposes only.

MODEL: RADIO TRANSMITTING SET AN/ART-13A MAJOR ASSEMBLY: RADIO TRANSMITTER T-47A/ART-13

References Symbol	Army Stock Number Navy Stock Number British Ref. Number	Name of Part and Description	Function	Mfr. and Desig. or Standard Type	Cont. or Govt. Dwg. or Spec. No.
C-109	3DA2-110.2	CAPACITOR: Fixed; mica; 2000 micromicrofarads $\pm 20\%$; 750 volts DCW; overall dimensions of case 2-1/4" x 1" x 3/8"; two solder lug terminals each with a 0.147" dia. hole, 1-3/4" between mtg/c; two 0.200" x 0.144" mounting holes, 23/32" between mtg/c. CAPACITOR: Same as C-109.	V-102 cathode by-pass capacitor	Sangamo Elec. BEW-15220-B20	Stewart-Warner 564522
C-110	3DA2-110.2	CAPACITOR: Same as C-109.	V-102 screen grid by-pass capacitor		
C-111	3D9460V	CAPACITOR ASSEMBLY: Six variable, ceramic capacitors; A-400-460, B-240-300, C-125-185, D-60-110, E-35-85, F-10-30, micromicrofarads; all mounted on a No. 6-32 threaded rod.	V-102 plate padding capacitor	Centralab 826-006	Stewart-Warner 564635
C-112	3D9250-67	CAPACITOR: Fixed; mica; 250 micromicrofarads $\pm 10\%$; 750 volts DCW; case dimensions overall 2-1/4" x 1" x 3/8"; two solder lug terminals each with a 0.147" dia. hole, 1-3/4" between mtg/c; two 0.200" x 0.144" mounting holes. CAPACITOR: Same as C-109.	V-103 grid coupling capacitor	Sangamo Elec. BEW-15325-B10	Stewart-Warner 564524
C-113	3DA2-110.2	CAPACITOR: Same as C-109.	V-103 cathode by-pass capacitor		
C-114	3DA2-110.2	CAPACITOR: Same as C-109.	V-103 screen grid by-pass capacitor		
C-115	3D9460V	CAPACITOR: Same as C-111.	V-103 plate padding capacitors		
C-116	3D9500-32	CAPACITOR: Same as C-108.	V-104 grid coupling capacitor		
C-117	3DA6-39.1	CAPACITOR: Same as C-106.	V-104 filament by-pass capacitor		
C-118	3DA2-9.2	CAPACITOR: Fixed; mica; 2000 micromicrofarads $\pm 20\%$; 3500 volts DCW; test voltage 7500 volts D.C.; case dimensions 1-25/32" x 1-11/32" x 3/4"; two No. 6-32 tapped holes through body, 1-1/4" between mtg/c, for terminals and mounting.	V-104 plate coupling capacitor	Sangamo Elec. A2L-7220-B20 Solar Mfg. Co. XMBW3.5-22-20 Cornell-Dubilier 9SL-72020	Stewart-Warner 564626
C-119	3DA2-34.3	CAPACITOR: Same as C-107.	V-104 screen filter capacitor		
C-120-A	3DA2-120.2	CAPACITOR: Fixed; mica; 2000 micromicrofarads $\pm 20\%$; 2500 volts DCW; test voltage 5000 volts D.C.; molded case; dimensions 1-5/8" x 1-1/8" x 29/64"; two 0.144" dia. mounting holes through case 1.312" between mtg/c; solder lug terminals. CAPACITOR: Same as C-120-A.	V-104 plate supply filter	AWS Type CM50B202M	
C-120-B	3DA2-120.2	CAPACITOR: Same as C-120-A.	V-104 plate supply filter		

C-121-A	3DA100-116.4	CAPACITOR: Fixed; paper; 3 section also consisting of C-121-B and C-121-C; each section 100,000 micromicrofarads $\pm 20\%$; 600 volts DCW; metal case acting as a common ground 1-13/16" x 1" x 3/4"; oil filled; two mounting feet each with a 3/16" dia. hole 2-1/8" between mtg/c; solder lug terminals. CAPACITOR: See C-121-A. CAPACITOR: See C-121-A. CAPACITOR ASSEMBLY: Consisting of two capacitors C-122-A and C-122-B; total capacity 100 micromicrofarads. CAPACITOR: Silver ceramic; 50 micromicrofarads $\pm 10\%$; 3/4" x 49/64" dia.; tapped No. 6-32 axial terminal hole at each end. CAPACITOR: Same as C-122-A.	Keying filter	Micamold 306-231 Sprague P-2947 Solar Mfg. Co. 3XDMRTW6-1-20	Stewart-Warner 564402
C-121-B		CAPACITOR: See C-121-A.	Keying filter		
C-121-C		CAPACITOR: See C-121-A.	Keying filter		
C-122		CAPACITOR ASSEMBLY: Consisting of two capacitors C-122-A and C-122-B; total capacity 100 micromicrofarads.			
C-122-A	3D9050-100	CAPACITOR: Silver ceramic; 50 micromicrofarads $\pm 10\%$; 3/4" x 49/64" dia.; tapped No. 6-32 axial terminal hole at each end.	V-104 plate tank padding capacitor	Centralab 850-003	Stewart-Warner 564187
C-122-B	3D9050-100	CAPACITOR: Same as C-122-A.	V-104 plate tank padding capacitor		
C-124		CAPACITOR ASSEMBLY: Consisting of three identical capacitors C-124-A, C-124-B, C-124-C; total capacity 201 micromicrofarads.			
C-124-A	3D9067	CAPACITOR: Silver ceramic; 67 micromicrofarads $\pm 5\%$; 3/4" x 49/64" dia.; tapped axial terminal hole at each end.	V-104 plate tank padding capacitor	Centralab 850-003	Stewart-Warner 564186
C-124-B	3D9067	CAPACITOR: Same as C-124-A.	V-104 plate tank padding capacitor		
C-124-C	3D9067	CAPACITOR: Same as C-124-A.	V-104 plate tank padding capacitor		
C-125		CAPACITOR ASSEMBLY: Variable; consisting of rotor (C-125-A) separate from stator (C-125-B).	V-104 plate tuning capacitor		
C-125-A	2C6900-47A/13	CAPACITOR, ROTOR: Complete with counterweight, cam, ball bearing, bearing retainer plug and nut, splined coupler, end shaft and contact ring.	Part of C-125 antenna network capacitor	General Inst. 314-R Hammond A-410-19-0	Stewart-Warner 564230
C-125-B	2C6900-47A/12	CAPACITOR, STATOR: Complete with E-129 insulators.		General Inst. 314-S Hammond Inst. Co. A-410-20-0	Stewart-Warner 564645
C-126	3DB2-37	CAPACITOR: Fixed; paper; 2 microfarads $\pm 20\%$; 600 volts DCW; test voltage 1200 volts D.C.; oil filled; metal case 2-3/4" x 1-13/16" x 1-1/16"; two solder lug terminals.	450 volt supply filter	Micamold 324 Sprague P-2948 Solar Mfg. Co. KLMRAW6-2-20 General Elec. Cat. No. 25F764	Stewart-Warner 564401
C-127	3DA6-21.1	CAPACITOR: Fixed; mica; 6000 micromicrofarads $\pm 20\%$; 750 volts DCW; test voltage 1500 volts D.C.; molded case; dimensions 1-13/64" x 1" x 3/8"; two terminal lugs each with a 0.147" dia. hole; two 0.200" x 0.144" mounting slots 23/32" between mtg/c. CAPACITOR: Same as C-118.	V-103 plate supply filter	Sprague Elec. BEW-15250 Sangamo Elec. BEW-15260-B20	Stewart-Warner 564523
C-128	3DA2-9.2	CAPACITOR: Same as C-118.	V-104 plate supply filter		
C-129	3D9050-100	CAPACITOR: Same as C-122-A.	V-104 plate tank padding capacitor		
C-130	3D9025-53	CAPACITOR: Silver ceramic; 25 micromicrofarads $\pm 10\%$; 3/4" x 49/64" dia.; tapped No. 6-32 terminal hole at each end.	V-104 plate tank padding capacitor	Centralab 850-001	Stewart-Warner 564185

TABLE OF PARTS (Cont'd)

NOTE: Parts listed which are indicated by a # sign in column 2 are not available as spare parts and are listed for reference purposes only.

MODEL: RADIO TRANSMITTING SET AN 'ART-13A MAJOR ASSEMBLY: RADIO TRANSMITTER T-47A /ART-13

Reference Symbol	Army Stock Number Navy Stock Number British Ref. Number	Name of Part and Description	Function	Mfr. and Desig. or Standard Type	Cont. or Govt. Dwg. or Spec. No.
C-131	3D9800-15	CAPACITOR: Fixed; mica; 800 micromicrofarads $\pm 5\%$; 750 volts DCW; test voltage 1500 volts D.C.; molded case; dimensions 1-13/64" x 1" x 3/8"; two lug terminals each with 0.147" dia. hole, 1-3/4" between mtg./c; two 0.200" x 0.144" mounting slots 23/32" between mtg./c.	V-102 plate supply filter	Sangamo Elec. BEW-15380-B.5 Cornell-Dubilier 140-LS	Stewart-Warner 564614
C-132	#	CAPACITOR: 4000 micromicrofarads $\pm 20\%$; 300 volts DCW; used only on Emerson motor D26BV-166-0212; mica; molded bakelite case.	Autotune motor spark suppressor capacitor	Emerson Elec. 96580-A	
C-133	#	CAPACITOR: Same as C-132.	Autotune motor spark suppressor capacitor		
C-134	3D9028V-3	CAPACITOR: Variable; air dielectric; 28-4.5 micromicrofarads; 1-23/32" x 1-7/32" x 15/16"; two tapped No. 4-40 mounting holes, 21/32" between mtg./c.	V-101 grid tank padding capacitor	Oak Mfg. 944-AT F. W. Sickles Hammerlund Mfg. Co. APC-25 "C"	Stewart-Warner 564516
C-135	3D9028V-3	CAPACITOR: Same as C-134.	V-101 grid tank padding capacitor		
C-136	3D9013V-2	CAPACITOR: Variable; ceramic; 3-13 micromicrofarads; 27/32" x 41/64" x 5/16"; two 0.120" mounting holes, 0.437" between mtg./c.	V-103 grid trimming capacitor	Centralab 822-009	Stewart-Warner 565634
C-137	3K3015221	CAPACITOR: Fixed; mica; 1500 micromicrofarads $\pm 10\%$; 500 volts DCW; test voltage 1000 volts D.C.; molded case; max. dimensions 53/64" x 53/64" x 9/32"; wire leads 1-3/8" long.	V-104 plate tank filter capacitor	AWS Type CM30B152K	
C-138	3DA100-375	CAPACITOR: Fixed; paper; 100,000 micromicrofarads $\pm 20\%$; 600 volts DCW; test voltage 1200 volts D.C.; metal case; liquid impregnated; hermetically sealed; single No. 6-32 tapped hole mounting; one solder lug terminal.	V-103 screen grid supply filter capacitor	P. R. Mallory Co. B-205985 J. E. Fast Co. A8066-DU	Stewart-Warner 564755
C-139	#	CAPACITOR: 3500 micromicrofarads; 500 volts DCW; used only on Ohio motors.	Autotune motor, brush filter capacitor	Cornell-Dubilier 1WS.0035	
C-140	#	CAPACITOR: Same as C-139.	Autotune motor, brush filter, capacitor		
C-141	#	CAPACITOR: Mica; molded; 2000 micromicrofarads; 500 volts DCW; used only on Fractional motors.	Autotune motor, brush filter, capacitor	Fractional Mtrs. CD801	
C-142	#	CAPACITOR: Same as C-141.			
C-145	3D415	CAPACITOR: CA-415; fixed; 2 section; 2 microfarads each section; $\pm 10\%$; 100 vdcw; 3-3/8" x 1-3/4" x 1".	Autotune motor filter		71-515 SC-D-3403
C-146	3DA10-27	CAPACITOR: fixed; 10,000 micromicrofarads; $\pm 10\%$; 300 vdcw.	Autotune motor filter	CM35B103K	JAN-C-5
C-147	3DA10-27	CAPACITOR: Same as C-146.			

C-148	3DA-100-84.3	CAPACITOR: fixed; paper; 100,000 micromicrofarads; $\pm 20\%$; 600 vdcw.	Autotune motor filter.	CP25AIEF104M	JAN-C-25
C-149	3DA-100-84.3	CAPACITOR: Same as C-148.	Brush for Emerson autotune motor	Emerson Elec. 94718-A Stackpole MP-1355	Stewart-Warner 564667
E-101-A	3H5255	BRUSH: Two required; used only on Emerson motors.	Brush for Ohio autotune motor	Ohio Motor Co. D-5699	Stewart-Warner 565547
E-101-B	3H525-17	BRUSH: Four required; used only on Ohio motors.	Brush for Fractional autotune motor	Fractional Mtr. FF811	Stewart-Warner 565548
E-101-C	3H525-18	BRUSH: Two required; used only on Fractional motors.	Transmitter pilot light	Drake Mfg. Co. No. 80 Dial Lite Co. DVT-90SAD RED	Stewart-Warner 564021
E-102	2ZK 5991-7	RECEPTACLE, PILOT LIGHT: Complete with ruby jewel and miniature bayonet socket; $3/8"$ I.D., $2-1/4" \times 15/16"$ dia.; two solder lug terminals.	Feed-through insulator used in multiplier unit. Also RE-CEIVER terminal	Centralab X-86 Gen. Ceramic D-350 Amer. Lava S-1173-A	Stewart-Warner 564488
E-103-A	3G1350-24	FEED-THROUGH: Ceramic; female; $3/8"$ h.; $1/2"$ dia. at top; $5/8"$ dia. at bottom; used with E-103-B.	Feed-through insulator used in multiplier unit. Also RE-CEIVER terminal	Gen. Ceramic D-2623 Centralab X-600	Stewart-Warner 564487
E-103-B	3G100-40.2	FEED-THROUGH: Ceramic; male; $5/8" \times 5/8"$ dia.; keyed; used with E-103-A.	Insulator for mounting	Centralab K-109 Gen. Ceramic D-328 Amer. Lava S-8556	Stewart-Warner 564403
E-104	3G1000-6.1	STAND-OFF: Ceramic; conical $3/4"$ h.; $3/8"$ dia. top; $1/2"$ dia. bottom; tapped No. 6-32 axial mounting hole at each end.	K-105 relay lead supports	Centralab X-91K Amer. Lava E-1000 tap No. 6-32	Stewart-Warner 564485
E-105	3G1250-16.5	STAND-OFF: Ceramic; cylindrical $1" \times 1/2"$ dia.; tapped No. 6-32 axial mounting hole at each end.	Used with E-106-B on LOAD COIL terminal	Centralab X-88 Gen. Ceramic D-431 Amer. Lava S-1174-A	Stewart-Warner 564882
E-106-A	3G1000-4.1	FEED-THROUGH: Ceramic; female; $1/2"$ h.; top dia. $3/4"$; bottom dia. $7/8"$.	Used with E-106-A on LOAD COIL	Centralab X-601 Gen. Ceramic D-2622 Amer. Lava S-13193	Stewart-Warner 564331
E-106-B	3G100-56.1	FEED-THROUGH: Ceramic; male; keyed; $7/8" \times 7/8"$ max. dia.	VARIOMETER terminals, C-111 and C-115 mounting	Centralab X-414 Oak 27429-H1C Gen. Ceramic D-2399	Stewart-Warner 564784
E-107	3G12503-13	FEED-THROUGH: Ceramic; bushing; $5/8"$ dia. $\times 3/16"$ thk.; I.D. 0.145".	Feed-through insulator in multiplier unit	Centralab X-87 Gen. Ceramic D-349 Amer. Lava S-1173-B	Stewart-Warner 564486
E-109-B	3G1250-10.11	FEED-THROUGH: Ceramic; male; $5/8" \times 5/8"$ dia. max.			

E-121	2Z3766-10	AUTOTUNE HEAD: Singleturn unit; complete with knob and locking device.	Control "E"	Collins Radio 96J-3 Sheaffer Pen 96J-3 Gen. Instrument	Stewart-Warner 564050
E-122	2Z2636-83	CLAMP, TUBE: Stainless steel; two 17/64" x 11/64" mounting slots; 1-25/32" between mtg./c.	For X-101, X-102, X-103, X-105 and X-106	Crown Cork Spec. NGA-1208B	Stewart-Warner 564434
E-123	6Z4875-5	GROMMET: Rubber; O.D. 2"; I.D. 1-7/32"; to fit 1-1/2" dia. hole.		Lavelle Rubber 11-427	Stewart-Warner 564307
E-124	6Z4914	GROMMET: Rubber; O.D. 1 1/32"; I.D. 1/8"; to fit 1/4" dia. hole.		Atlantic India Rubber Co. 54-9	Stewart-Warner 564073
E-125	6Z4876-3	GROMMET: Rubber; O.D. 9/16"; I.D. 9/32"; to fit 3/8" dia. hole.		Canfield Rubber 1975	Stewart-Warner 564418
E-126	2Z5843-12	KNOB: Complete with H-2601 set screw; black bakelite; over-all dimensions 1-1/8" x 3/4" x 11/16"; same as E-2605.	Various switch knobs	Chicago Die Mld.	Stewart-Warner 564753
E-127	#	CONTACT ARM ASSEMBLY: Complete with spring, collar and pin.	Part of switch S-113-A		Stewart-Warner 564115
E-128	2Z9404-152	BOARD, TERMINAL: Bakelite; 1-13/16" x 3/8" x 1/8"; four connecting terminals.	H.F.O. terminal board	H. B. Jones 4-1-W1	Stewart-Warner 564356
E-129	#	INSULATOR: Fused quartz or pyrex glass; 0.625" dia. 0.751" at Saturn ring; 4 used.	C-125 stator insulator	Hartford Steel Ball Company	Stewart-Warner 564313
E-130	2Z3262-6	IRON CORE: 1-1/2" x 0.312"; No. 6-32 brass mounting stud 1" long.	Tuning slug for L-105	Ferrocarril Inc. S-614-70BR Stackpole C-9263	Stewart-Warner 564398
E-131	2Z3262-6	IRON CORE: Same as E-130.	Tuning slug for L-106	Emerson Elec. Co. 96254-A	
E-132	#	CAP, BRUSH HOLDER: For Emerson motor.	Brush holder cap		
E-133	#	CAP, BRUSH HOLDER: For Ohio motor.	Brush holder cap	Ohio Elec. Co. D3689	
E-134	#	CAP, BRUSH HOLDER: For Fractional motor.	Brush holder cap	Fractional Mtr. FF825	
E-135	#	ROTOR ASSEMBLY: Steel shaft with 11 bakelite cams.	Part of switch S-113		Stewart-Warner 564125
E-136	#	FRONT PLATE: Mycalex or equivalent; 4.160" x 3-1/8" x 1/8".	Part of switch S-113		Stewart-Warner 564171
E-137	#	CONTACT ASSEMBLY: Consisting of five rocker arm contacts and mycalex mounting board.	Part of switch S-113		Stewart-Warner 564162
E-138	#	CONTACT ASSEMBLY: Consisting of six leaf contact arms and mounting board.	Part of switch S-113		Stewart-Warner 564108
E-139	2Z3724-30	DIAL: Knob.	Control "A"	Sheaffer Pen Co. 1069B-2	Stewart-Warner 565678
E-140	2Z3720-4	DIAL: Knob.	Control "B"	Sheaffer Pen Co. X-5524	Stewart-Warner 565680
E-141	2Z3724-31	DIAL: Knob.	Control "C"	Sheaffer Pen Co. 1072B-2	Stewart-Warner 565674
E-142	2Z3718-53	DIAL: Knob.	Control "D"	Sheaffer Pen Co. X-5586	Stewart-Warner 565676

TABLE OF PARTS (Cont'd)

NOTE: Parts listed which are indicated by a # sign in column 2 are not available as spare parts and are listed for reference purposes only.

MODEL: RADIO TRANSMITTING SET AN/ART-13A MAJOR ASSEMBLY: RADIO TRANSMITTER T-47A/ART-13

Reference Symbol	Army Stock Number Navy Stock Number British Ref. Number	Name of Part and Description	Function	Mfr. and Desig. or Standard Type	Cont. or Govt. Dwg. or Spec. No.
E-143	2Z3766-1	DIAL: Knob.	Control "E"	Sheaffer Pen Co. X-5796	Stewart-Warner 565672
E-144	#	DIAL: Revolution counter.	For Control "B"	Sheaffer Pen Co. X-5527	
E-145	#	KNOB.	For CORRECTOR on control "B"	Sheaffer Pen Co. X-5531	
E-146	#	DISC, LOCKING ASSEMBLY.		Sheaffer Pen Co. X-5620	
H-101	6R55231	WRENCH, BRISTO: Multiple spline; 6 flutes; for No. 8 Bristo set screw.	Socket screw, wrench	Supplies Inc.	Stewart-Warner 564259
H-102	6RK5230-10	WRENCH, BRISTO: Multiple spline; 6 flutes for No. 10 Bristo set screw.	Socket screw, wrench	Supplies Inc.	Stewart-Warner 564260
H-103	6RK55232	WRENCH, BRISTO: Multiple spline; 6 flutes; for No. 4 Bristo set screw.	Socket screw, wrench	Supplies Inc. Bristol Mfg. Co.	Stewart-Warner 564257
H-104	6R55230	WRENCH, BRISTO: Multiple spline; 6 flutes; for No. 6 Bristo set screw.	Socket screw, wrench	Supplies Inc.	Stewart-Warner 564258
H-105	6R18338-1	SCREW DRIVER, PHILLIPS: L shape; No. 1 Phillips head on each end; 3-1/4" x 1".	Phillips screw driver	Apex Mach. No. 721 Spec. Rosenberg Bros. No. 1 Offset	Stewart-Warner 564261
H-106	6R18338	SCREW DRIVER, PHILLIPS: L shape; No. 2 Phillips head on each end; 4" x 1-5/16".	Phillips screw driver	Apex Mach. No. 722 Spec. Rosenberg Bros. No. 2 Offset	Stewart-Warner 564262
H-107	2C6900-47/C9	CRANK: 1-7/16" x 1-3/8" x 1/2"; steel.	For checking and adjusting Autotune mechanism		Stewart-Warner 565090
H-108	6R57512	WRENCH: Approx. 2-3/4" x 1/2" x 0.075"; bent at 30° angle, steel.	C-125 adjusting wrench	Gen. Eng. & Mfg. Job No. 2729	Stewart-Warner 564274
H-109	6R57511	WRENCH: Approx. 3-1/8" x 0.828" x 0.060"; bent at 20° angle; steel.	C-125 rotor adjusting wrench		Stewart-Warner 564287
H-110		SHOCK MOUNT: Left; complete with knob assembly and latch.	Used on transmitter		Stewart-Warner 564920
H-111		SHOCK MOUNT: Right; complete with knob assembly and latch.	Used on transmitter		Stewart-Warner 564910
I-101	2Z5938	LAMP: Bayonet base 3/8" dia.; clear glass; overall dimensions 1-1/8" x 7/16" dia.	Indicating lamp	General Elec. 3-1/4 Cat. No. 313	Stewart-Warner 564022

J-101	2Z5534A	JACK: Phone; midget size; single circuit; to fit plug with 1/4" barrel; two solder lug terminals.	Jack for throttle switch plug	Natl. Fab. Prod. JK 34-A Mallory B-116849	Stewart-Warner 564692
J-102	2Z5533A	JACK: Phone; midget; three circuit; to fit plug with 3/16" barrel; overall dimensions 1-3/16" x 29/32" dia.; 3 solder lug terminals.	Jack for microphone plug	Natl. Fab. Prod. JK-33A Mallory SC1A	Stewart-Warner 564023
J-103	2Z5534A	JACK: Same as J-101.	Jack for key plug		
J-104	2Z5534A	JACK: Same as J-101.	Jack for Side Tone No. 1 plug.		
J-105	2Z5534A	JACK: Same as J-101.	Jack for Side Tone No. 2 plug		
J-106	2Z8697.4	CONNECTOR: Female; 27 pin; wall mounting type by four 0.169" dia. holes; all contacts rated 10 amperes; overall dimensions 1-5/16" x 1-5/16" x 1-5/64" thk.	Connector to pilot's control box cable	Cannon Elec. Dev. RNK-27-31SL-3, 4	Stewart-Warner 564764
J-107	2Z8673.46	CONNECTOR: Female; 3 pin; wall mounting type by four 0.144" dia. holes; two contacts rated 10 amperes; overall dimensions 1-5/16" x 1-5/16" x 1-9/64" thk.	28 volt supply connector to loading coil.	Cannon Elec. Dev. RWK-C3-31SL-3, 4	Stewart-Warner 564763
J-108	2Z7120.13	CONNECTOR: Male; 10 pin; wall mounting type by four 0.144" dia. holes; two contacts rated 15 amperes; 8 contacts rated 10 amperes; screw-on lock; overall dimensions 1-7/8" x 1-7/8" x 29/32" thk.	Connector to power unit cable	Cannon Elec. Dev. FK-10-32S-3, 5	Stewart-Warner 564762
J-109	3Z741-13.1	POST, BINDING: Push type; accommodates a 0.110" dia. wire; overall dimensions 1-13/32" x 1/2" dia.; black bakelite cap; supplied with keying pin.	Binding post marked "ANT"	H. H. Eby Co. 7247	Stewart-Warner 564296
J-110		POST, BINDING: Push type; accommodates a 0.110" dia. wire; 2-1/16" x 1/2" dia.; black bakelite cap; keyed.	Binding post marked "RECEIVER"	H. H. Eby Co. 7310	Stewart-Warner 564297
J-111	2Z8639-15	CONNECTOR: Female; 8 terminal; terminal numbers on both sides of connector; molded case; dimensions 1-1/4" x 1-1/16" x 1/2"; two mounting feet with a 0.146" hole 1" between mtg/c; solder lug terminals.	Connector for C.F.I. unit	H. B. Jones S-308-AB A. W. Franklin 40A7	Stewart-Warner 564806
J-112	2Z7403-3	CONNECTOR: Female; 12 terminal; terminal numbers on both sides of connector; molded case; dimensions 1-1/4" x 1-1/16" x 1/2"; two mounting feet each with a 0.146" dia. hole, 1-1/4" between mtg/c; solder lug terminals.	Connector for audio amplifier unit	H. B. Jones S-312-AB-W1 A. W. Franklin 40A4	Stewart-Warner 564677
J-113	3Z737-32	POST, BINDING: Push type; accommodates a 0.110" dia. wire; black bakelite cap; 13/16" x 1/2" dia.; keying pin.	Binding post marked "GROUND"	H. H. Eby Co. 62KD Soreng-Mangold 10,000 series	Stewart-Warner 564228
J-114	2Z8639-16	CONNECTOR: Female; 6 terminals; terminal numbers on both sides of connector; molded case 1" x 1-1/16" x 9/16"; two mounting feet each with a 0.146" dia. hole, 1" between mtg/c; solder lug terminals.	Connector to L.F.O. unit	H. B. Jones S-306-AB-W1 A. W. Franklin S-306 AB	Stewart-Warner 564678
J-115	2Z3032-6	CONNECTOR: Male; octal; 12 pins; pins numbered; molded body; overall dimensions 1-1/32" x 1-3/32" dia.	Male connector to multiplier unit	Amer. Phenolic 70-12	Stewart-Warner 564804
J-116	2Z8685	CONNECTOR: Female; 15 terminals; terminal numbers on both sides of connector; molded case 1-5/8" x 1" x 1/2"; two mounting feet each with a 0.146" dia. hole 1-3/8" between mtg/c; solder lug terminals.	Connector to keying relay K-102	H. B. Jones S-315-AB A. W. Franklin 40A6	Stewart-Warner 564805
J-117	3Z741-13	POST, BINDING: Push type; accommodates a 0.110" dia. wire; 2-3/8" x 1/2" dia.; black bakelite cap; keyed.	Binding post marked "LOAD COIL"	H. H. Eby Co. 7311	Stewart-Warner 564295

TABLE OF PARTS (Cont'd)

NOTE: Parts listed which are indicated by a # sign in column 2 are not available as spare parts and are listed for reference purposes only.

MODEL: RADIO TRANSMITTING SET AN ART-13A MAJOR ASSEMBLY: RADIO TRANSMITTER T-47A /ART-13

Reference Symbol	Army Stock Number Navy Stock Number British Ref. Number	Name of Part and Description	Function	Mfr. and Desig. or Standard Type	Cont. or Govt. Dwg. or Spec. No.
J-118	3Z741-13.1	POST, BINDING: Same as J-109.	Binding post marked "COND"	Leach Relay Co. 2069	Stewart-Warner 564532
K-101	2Z7592-41	RELAY: 3 pole double throw; contacts rated 15 amperes, 28 volts; continuous non-inductive load; nominal coil voltage 28 volts D.C.; coil resistance 130 ohms min.; overall dimensions 2-11/32" x 1-3/4" x 1-11/16"; base has four 0.152" dia. mounting holes, 1.375" between mtg/c; solder lug terminals.	Motor reversing relay	Graybar Elec. Guardian Elec. G-36458 G.M. Laboratories 12957	
K-102	2Z7595-7	RELAY: Three S.P.S.T., contacts normally open; one S.P.S.T., contacts normally closed; two S.P.D.T., and one S.P.D.T. vacuum switch; nominal coil voltage 28 volts D.C.; coil resistance 2 coils each 27 ohms in series; all contacts rated 28 volts, 8 amperes continuous non-inductive load; complete with vacuum switch S-116.	Keying relay	R.B.M. Mfg. Co. No. 30,000 Guardian Elec. G-36456 Potter & Brumfield Mfg. Co. KVS-630 John W. Clark 78CCA Struthers-Dunn 78CC A101	Stewart-Warner 564699
K-103	2Z7592-42	RELAY: 2 P.D.T.; one auxiliary pole normally open; coil voltage 28 volts D.C. nominal; coil resistance 115 ohms min.; main contacts rated 12 amperes, 28 volts D.C. continuous non-inductive load; auxiliary contacts 8 amperes, 28 volts D.C. continuous non-inductive load; overall dimensions 3-5/32" x 1-3/4" x 1-13/16"; base has 4 tapped No. 8-32 mounting holes.	C.W. emission relay	Allied Control HRX-9-D-35 Leach Relay Co. 1067-ABFW Guardian Elec. G-36459 G.E. No. CR2791D105E3	Stewart-Warner 564651
K-104	2Z7589-85	RELAY: 2 P.D.T.; coil voltage nominal 28 volts D.C.; coil resistance 135 ohms min.; contacts rated 12 amperes 28 volts D.C. continuous non-inductive load; overall dimensions 2-3/4" x 1-5/8" x 1-9/16"; base has four No. 8-32 tapped mounting holes 2.375" x 0.625" between mtg/c; solder lug terminals.	Voice emission relay	Leach Relay Co. 1087-W Graybar Elec. HRX-1 Guardian Elec. G-36457	Stewart-Warner 564533
K-105	2Z7592-45	RELAY: 6-1/32" x 3-1/8" x 1-31/32"; two coils in series, each 30 ohms resistance; two tapped No. 8-32 mounting holes, 0.937" between mtg/c.	Output circuit selecting relay	R.B.M. Mfg. Co. 30200 Guardian Elec. G-36427-E	Stewart-Warner 564930
L-101	2C6900-47/C2	COIL: Oscillator; complete with tuning slug; operated by "B" dial; ceramic coil form 3-7/8" x 1-3/8" dia.; rust-proofed iron core slug 1-1/2" x 0.682"; two terminal pins.	H.F. oscillator coil	Aladdin Radio 49-155 F. W. Suckles	Stewart-Warner 564444

L-102	3C326-100.2	COIL, CHOKE R.F.: 4 pie universal winding; No. 36 S.S.E. wire; dimensions 1-15/16" x 1/2" dia.; 2.5 millihenries inductance at 1000 C.P.S. in air, single mounting hole tapped for No. 6-32 screw; terminals, two brass cotter pins.	H.F. oscillator cathode R.F. choke	E. I. Guthman 30-521 National Co. R-100U	Stewart-Warner 564609
L-103	3C326-100.1	COIL, CHOKE R.F.: Same as L-102.	H.F. oscillator screen grid R.F. choke		
L-104	3C357-18	COIL, CHOKE R.F.: Two pie universal wound; inductance in air at 1000 C.P.S. approx. 202 microhenries; 15/16" x 37/64" dia.; axial wire leads.	H.F. oscillator plate feed choke	E. I. Guthman 30-5218 Standard Winding A-546	Stewart-Warner 564520
L-105	S/N 2C6900-47/C3	COIL, R.F.: 28 turns number 24DE Copper Wire; bakelite coil form, 1-7/8" x 7/8" diameter; 2 No. 4-40 screw terminals; three No. 6-32 mounting holes.	V-102 plate tuning coil	Stewart-Warner 564625 General-Electric ML-7470068G-1	Stewart-Warner 564625
L-106	S/N 2C6900-47/C4	COIL, R.F.: 9 turns No. 24DE. Copper Wire; bakelite coil form 1-9/16" x 7/8" diameter; two No. 4-40 screw terminals; three No. 6-32 mounting holes.	V-103 plate tuning coil	Stewart-Warner 564620 General-Electric ML-7470067G-1	Stewart-Warner 564620
L-107	3C326-100	COIL, CHOKE R.F.: 4 pie, universal winding; inductance 2.5 millihenries in air at 1000 C.P.S.; resonance 2400 Kc; dimensions 2" x 1/2"; wire leads.	P.A. grid feed choke	National Co. Inc. R-100 E. I. Guthman 30-5222	Stewart-Warner 564637
L-108	3C357-27	COIL, CHOKE R.F.: 175 turns; single layer; ceramic coil form; 5-5/8" x 1-7/16" dia.; inductance 91 microhenries in air at 1000 C.P.S.; two No. 6-32 tapped holes for mounting; two terminal pins.	P.A. plate feed choke	Stewart-Warner 564628 General Electric ML-7891579-1	Stewart-Warner 564628
L-109	3C57-20	COIL, CHOKE R.F.: 5 pie universal winding; inductance 6 millihenries in air at 1000 C.P.S. No. 30 S.S.E. wire; overall length 3-7/16"; 1-1/16" dia.; single No. 6-32 tapped mounting hole; special solder lug terminals.	P.A. plate feed choke	Standard Winding A 554 E. I. Guthman 30-5219	Stewart-Warner 564527
L-110	3C357-22	COIL, CHOKE R.F.: 325 turns No. 35 S.S.E. wire; inductance 190 millihenries; ceramic core 4" x 7/16"; single No. 6-32 tapped hole for mounting; two special band type terminals.	Output network static drain choke	Stewart-Warner 564627 General-Electric ML-7890826-1	Stewart-Warner 564627
L-112	3C2527	VARIOMETER: Furnished complete (rotor and stator coils) with coupling.	P.A. plate tank inductor control "D"	Centralab 40-001 Hammerlund	Stewart-Warner 564770
L-113	2C6900-47/C13	COIL: Antenna loading; 43 turns No. 14 tinned copper wire; 5 taps; ceramic core 4-5/16" x 2-1/2" dia.; four No. 8-32 tapped mounting holes in base; solder lug terminals.	Antenna loading inductor	Soreng-Mangold 11603B	Stewart-Warner 564190
L-114	2C6900-47/C12	COIL: Padding inductor; single layer; 15 turns No. 16 tinned copper wire; inductance 2 microhenries; ceramic coil form 1-5/8" x 3/4" dia.; two mounting holes in each end tapped for No. 6-32 screws; wire leads.	P.A. plate tank padding inductor	Stewart-Warner 564182 General-Electric ML-7891326-1	Stewart-Warner 564182
L-115	3C326-100.1	COIL, CHOKE R.F.: Same as L-102.	1st multiplier plate feed choke		
L-116	3C326-300.1	COIL, CHOKE R.F.: Three pie universal winding; No. 32 S.S.E. wire; inductance 1.0 millihenry \pm 10% in air at 1000 C.P.S.; overall dimensions 1-15/16" x 1/2" dia.; ceramic core; single No. 6-32 tapped mounting hole; two brass cotter pin terminals.	H.F. noise filter choke	Standard Windg. A-545-1 E. I. Guthman 30-5220 National Co. R-300U	Stewart-Warner 564633

T. O. 12R2-2ART13-2

TABLE OF PARTS (Cont'd)

NOTE: Parts listed which are indicated by a # sign in column 2 are not available as spare parts and are listed for reference purposes only.

MODEL: RADIO TRANSMITTING SET AN / ART-13A MAJOR ASSEMBLY: RADIO TRANSMITTER T-47A / ART-13

Reference Symbol	Army Stock Number Navy Stock Number British Ref. Number	Name of Part and Description	Function	Mfr. and Desig. or Standard Type	Cont. or Govt. Drug. or Spec. No.
L-117	3C326-300.1	COIL, CHOKE R.F.: Same as L-116.	Screen grid filter for multiplier tubes	Weston Electric 507TH-MA250-	Stewart-Warner 564749
M-101	3F1005-43	METER: Antenna current; internal thermocouple; R.F.; frequency range 0-20 Mc; 0-0.25 ampere; expanded scale characteristics; 0-5 scale; 20 times normal scale; moulded phenolic case 1.980" x 2.210" dia.; flange 2.695" dia.; furnished with three No. 4-40 mounting bolts; two No. 1/4-28 terminal bolts.	Antenna current ammeter	MASC-0-5 General-Electric 8DW52AAR84	
M-102	3F6299-2	METER: D.C. milliammeter; 0-1 milliamperes $\pm 2\%$; resistance 42 ohms $\pm 20\%$; special scale marked P.A. PLATE, P.A. GRID, BATTERY; moulded phenolic case 1.980" x 2.210" dia.; flange 2.695" dia.; furnished with three No. 4-40 mounting bolts.	Voltage and current indicating meter	General-Electric 8DW51ADK84 Weston 506MALMADGSC-0-200	Stewart-Warner 564751
O-101	2C6900-47A/1	MAIN LINE-SHAFT ASSEMBLY: Includes shaft, thrust bearings, worm gears, sprocket and taper groove pins; parts wired together, must be assembled in the field.	Main line shaft	Stewart-Warner 565480 General Electric M-7472216	Stewart-Warner 565480
O-102	2C6900-47A/4	SPROCKET, MOTOR: With one No. H-112 set screw, stainless steel; 0.901" dia. x 3/8" thick.	B-101 motor sprocket	Link Belt Co., ES-15730, ES-12379, Morse Chain Co. DB-17118	Stewart-Warner 564895
O-103	2C6900-47A/9	CHAIN, AUTOTUNE DRIVE: Stainless steel or monel metal.	Connects B-101 to main line-shaft	Link Belt Co. ES-12381 Morse Chain Co. 18-1708	Stewart-Warner 564276
O-104	#	DIAL, LOCKING BAR.	One multiturn, Autotune head	Sheaffer Pen X 5525	Stewart-Warner 564644
O-105	2C6900-47A/8	MULTITURN LINE-SHAFT ASSEMBLY: Includes shaft, thrust bearings, worm gears and taper groove pins; parts wired together, must be assembled in the field.	In multiturn, Autotune head	Stewart-Warner 565598 General Electric	Stewart-Warner 565598
O-106	#	BEARING: Oilite, 0.375" x 0.314" dia.; I.D. 0.189".	LINE-SHAFT bearing.	Chrysler Corp. A-339-2 Industrial Sprg. 63-H2	Stewart-Warner 564354
P-101	2Z3073-4	CONNECTOR: Octal; female; 12 terminal; black bakelite with moulded-in mounting plate; overall dimensions 1-7/8" x 1-9/32" x 13/16"; two 5/32" dia. mounting holes 1-1/2" between mtg/c; solder lug terminals.	Multiplier unit connecting plug	American Phenolic MIP-12M	Stewart-Warner 564519
P-102	#	CONNECTOR: Male; 15 terminals; molded case; 1-5/8" x 1" x 1/2"; two mounting feet each with a 0.146" dia. hole; 1-3/8" between mtg/c.	Part of keying relay K-102		

R-101	3RC31BF223K	RESISTOR: Fixed; carbon; 22,000 ohms $\pm 10\%$; 1 watt; insulated; max. dimensions 1.280" x 0.310"; 1-1/2" axial wire leads.	H.F. oscillator grid	JAN Type RC31BF223K	Stewart-Warner 564435
R-102	3RC31BF104K	RESISTOR: Fixed; carbon; 100,000 ohms $\pm 10\%$; 1 watt; insulated; max. dimensions 1.280" x 0.310"; 1-1/2" axial wire leads.	V-102 grid resistor	JAN Type RC31BF104K	
R-103	3RC30BF470M	RESISTOR: Fixed; carbon; 47 ohms $\pm 20\%$; 1 watt; insulated; max. dimensions 0.718" x 0.280"; 1-1/2" axial wire leads.	V-102 grid parasitic suppressor	JAN Type RC30BF470M	
R-104	3RC30BF470M	RESISTOR: Same as R-103.	V-102 screen grid parasitic suppressor		
R-105	3Z6620-102	RESISTOR: Fixed; wire wound; 20,000 ohms $\pm 10\%$; 13.5 watts in open air; max. voltage 520 volts; max. current 26 milliamperes; brown vitreous enameled; overall dimensions 2" x 1-7/32" x 11/16"; two radial lug terminals each with a 1/8" dia. hole.	V-102 screen grid circuit	Federal Elec. 169 Ward-Leonard 2" T-20,000-219	
R-106	3RC30BF470M	RESISTOR: Same as R-103.	V-103 grid parasitic suppressor		
R-107	3RC31BF104K	RESISTOR: Same as R-102.	V-103 grid circuit		
R-108	3RC30BF470M	RESISTOR: Same as R-103.	V-103 screen grid parasitic suppressor		
R-109	3Z6620-102	RESISTOR: Same as R-105.	V-103 screen grid circuit		
R-110	3Z6620-102	RESISTOR: Same as R-105.	V-104 grid circuit		
R-111	3Z66023E5	RESISTOR: Fixed; wire wound; 235 ohms $\pm 2\%$; 1 watt; max. voltage 15.3 volts; 65.2 milliamperes; ceramic form; wound non-inductively with enameled 0.0014" dia. wire; body dimensions 9/16" x 9/16" dia.; 9/64" radial hole for mounting radial solder lugs.	V-104 grid metering resistor	JAN Type I.R.C. WW-3 Shall Cross Mfg. 183 A	Stewart-Warner 564743
R-112	3RC30BF470M	RESISTOR: Same as R-103.	V-104 screen grid parasitic suppressor		
R-113	3Z6015-65	RESISTOR: Fixed; wire wound; 150 ohms $\pm 20\%$; 10 watts; max. voltage 38 volts; max. current 258 milliamperes; brown vitreous enameled; 3/16" dia. axial mounting hole; two radial solder lugs each with a 1/8" dia. hole.	K-102 relay filter	Federal Elec. 134 I.R.C. AB Ohmite 18763	Stewart-Warner 564435
R-114	3Z6015-65	RESISTOR: Same as R-113.	K-102 relay filter		
R-115	3Z6010-60	RESISTOR: Fixed; wire wound; 100 ohms $\pm 10\%$; 25 watts; max. voltage 50 volts; max. current 500 milliamperes; brown vitreous enameled; overall dimensions 2" x 1-7/32" x 11/16"; 5/16" axial mounting hole; two radial solder lugs each with a 1/8" dia. hole.	K-101 relay spark suppressor	Federal Elec. 162 Ward-Leonard 2" T-100-219 Lectrohm Inc. 2S	Stewart-Warner 564517
R-116	3Z5991-48	RESISTOR: Fixed; wire wound; 1 ohm $\pm 10\%$; 10 watts; max. voltage 3 volts; max. current 3.150 milliamperes; brown vitreous enameled; overall dimensions 1-3/4" x 11/16" x 3/8"; 3/16" axial mounting hole; radial solder lug terminals each with a 1/8" dia. hole; 1-7/16" between mtg./c.	Filament voltage dropping resistor	Federal Elec. 166 Ward-Leonard 1-3/4 Z-50-236 Ohmite Mfg. 18764 I.R.C. AB	Stewart-Warner 564679
R-117	3Z6500-103	RESISTOR: Fixed; wire wound; 5000 ohms $\pm 10\%$; 25 watts; max. voltage 350 volts; max. current 70 milliamperes; brown vitreous enameled; overall dimensions 2" x 1-7/32" x 11/16"; 5/16" axial mounting hole; two radial solder lug terminals each with a 1/8" dia. hole, 1-7/32" between mtg./c.	400 volt supply, bleeder resistor	Federal Elec. 163 Ward-Leonard 2" T-5000-215 Lectrohm Inc. 2S Ohmite Mfg. Co. 18761	Stewart-Warner 564518

TABLE OF PARTS (Cont'd)

NOTE: Parts listed which are indicated by a # sign in column 2 are not available as spare parts and are listed for reference purposes only.

MODEL: RADIO TRANSMITTING SET AN ART-13A MAJOR ASSEMBLY: RADIO TRANSMITTER T-47A ART-13

Reference Symbol	Army Stock Number Navy Stock Number British Ref. Number	Name of Part and Description	Function	Mfr. and Desig. or Standard Type	Cont. or Govt. Dwg. or Spec. No.
R-118	3Z6500-103	RESISTOR: Same as R-117.	400 volt supply, bleeder resistor		
R-119	3Z6500-103	RESISTOR: Same as R-117.	400 volt supply, bleeder resistor		
R-120	3Z6500-103	RESISTOR: Same as R-117.	400 volt supply, bleeder resistor		
R-121	3Z5988-2	RESISTOR: Fixed; wire wound; 0.8 ohms $\pm 10\%$; 50 watts; max. voltage 6.32 volts; max. current 7900 milliamperes; brown vitreous enameled; overall dimensions 4" x 1-7/32" x 11/16"; 5/16" axial mounting hole; two radial solder lug terminals each with a 1/8" dia. hole 3-17/32" between mtg./c.	Filament, voltage dropping, resistor	Federal Elec. 170 Ward-Leonard 4" T-O. 8-219 Ohmite Mfg. Co. 18769 I.R.C. Special D	Stewart-Warner 564440
R-123	3Z6001B2-29	RESISTOR: Fixed; wire wound; 12.6 ohms $\pm 10\%$; 25 watts; max. voltage 17.75 volts; max. current 1408 milliamperes; brown vitreous enameled; overall dimensions 2" x 1-7/32" x 11/16"; 5/16" axial mounting hole; two radial solder lug terminals; each with a 1/8" dia. hole, 1-17/32" between mtg./c.	Modulator tubes filament shunt	Federal Elec. 167 Ward-Leonard 2" T-12.6-219 Ohmite Mfg. Co. 18767 I.R.C. D.G.	Stewart-Warner 564437
R-124	3Z6625-103	RESISTOR: Fixed; wire wound; 25,000 ohms $\pm 10\%$; 11 watts; max. voltage 533 volts; max. current 24 milliamperes; brown vitreous enameled; overall dimensions 2" x 1-7/32" x 11/16"; 5/16" axial mounting hole; two radial solder lug terminals, each with a 1/8" dia. hole, 1-17/32" between mtg./c.	V-104 screen, voltage dropping, resistor	Federal Elec. 168 Ward-Leonard 2" T-25000-219 I.R.C. D.G.	Stewart-Warner 564438
R-128	3Z6400-61	RESISTOR: Fixed; wire wound; 4000 ohms $\pm 2\%$; 1 watt; max. voltage 63.2 volts; max. current 15.8 milliamperes; 0.014" dia. enameled wire wound non-inductively; ceramic form 9/16" x 9/16" dia.; 9/64" dia. axial mounting hole; two radial solder lug terminals.	M-102 meter multiplier	I.R.C. WW-3 Shall Cross Mfg. 183A	Stewart-Warner 564744
R-129	3Z6100-6	RESISTOR: Fixed; wire wound; 1000 ohms $\pm 10\%$; 10 watts; max. voltage 100 volts; max. current 100 milliamperes; brown vitreous enameled; overall dimensions 1-3/4" x 11/16" x 3/8"; 3/16" axial mounting hole; two radial solder lug terminals each with a 1/8" dia. hole, 1-7/16" between mtg./c.	V-103 cathode biasing resistor	Federal Elec. 164 Ward-Leonard 1-3/4" T-1000-236 Ohmite Mfg. 19095 Lectrohm Inc. 1-3/4" EX	Stewart-Warner 564521
R-130	3Z6100-6	RESISTOR: Same as R-129.	V-102 cathode biasing resistor		
R-131	3Z6035-17	RESISTOR: Fixed; wire wound; 350 ohms $\pm 10\%$; 10 watts; max. voltage 59 volts; max. current 169 milliamperes; brown vitreous enameled; overall dimensions 1-3/4" x 11/16" x 3/8"; 3/16" axial mounting hole; two radial solder lug terminals each with a 1/8" dia. hole; 1-7/16" between mtg. c.	Oscillator cathode resistor	Federal Elec. 133 Ward-Leonard 1-3/4" T-350-236 Ohmite Mfg. Co. 18762 I.R.C. AB.	Stewart-Warner 564436

R-132	3Z6650-130	RESISTOR: Fixed; wire wound; 50,000 ohms $\pm 2\%$; 0.8 watt; max. voltage 200 volts; max. current 4.0 milliamperes; 0.0014" dia. enameled wire wound non-inductively; ceramic form 9/16" x 9/16" dia.; 9/64" dia. axial mounting hole; two axial solder lug terminals.	M-102 meter multiplying resistor	I.R.C. WW-3 Shall Cross 183 A	Stewart-Warner 564742
R-133	3Z6005-64	RESISTOR: Fixed; wire wound; 50 ohms $\pm 10\%$; 10 watts; max. voltage 22 volts; max. current 447 milliamperes; brown vitreous enameled; overall dimensions 1-3/4" x 11/16" x 3/8"; 3/16" dia. axial mounting hole; two radial solder lug terminals, each with a 1/8" dia. hole, 1-7/16" between mtg./c.	V-101 filament, voltage dropping resistor	Federal Elec. 165 Ward-Leonard 1-3/4" Z-50-236 Lectrohm Inc. 1-3/4 EX	Stewart-Warner 564681
R-134	3Z6007F5-18	RESISTOR: Fixed; carbon or wire wound; 75 ohms $\pm 10\%$; 1/2 watt; insulated; max. inductance 4.0 microhenries; max. dimensions 0.655" x 0.249" dia.; 1-1/2" axial wire leads.	Radio amplifier input terminating	I.R.C. BW 1/2 Speer S1-1/2 Stackpole CM1/2	Stewart-Warner 564389
R-135	3Z6001-3	RESISTOR: Fixed; carbon or wire wound; 10 ohms $\pm 10\%$; 1/2 watt; max. inductance 4.0 microhenries; max. dimensions 0.655" x 0.249" dia.; insulated; 1-1/2" axial wire leads.	MCW oscillator cathode	I.R.C. BW1/2 Speer S1-1/2 Stackpole CM1/2	Stewart-Warner 564388
R-136	3Z6015-65	RESISTOR: Same as R-113.	I-101, voltage dropping, resistor		
R-137	3RC31BF223M	RESISTOR: Fixed; carbon; 22,000 ohms $\pm 20\%$; 1 watt; max. dimensions 1.280" x 0.310" dia.; two 1-1/2" axial wire leads.	V-104 grid resistor TUNE position	JAN Type RC31BF223M	General Electric ML-7894058-1
S-101		SWITCH: Consists of two parts S-101A and S-101B, operated by control "A".	High frequency oscillator band switch	General Electric ML-7894058-1	General Electric ML-7894058-1
S-101A	3Z8101/1	SWITCH: Moving arm assembly; 1-11/16" x 5/16" x 1/4"; two 0.140" dia. mounting holes, 1/4" between mtg./c.	Part of S-101	Stewart-Warner 564445	Stewart-Warner 564445
S-101B	3Z8101/2	SWITCH: Stator assembly; bakelite insulating block with beryllium copper contact arm 1-7/16" x 1" approx. 1/4"; two tapped No. 6-32 mounting holes, 3/4" between mtg./c.	Part of S-101	Stewart-Warner 564447	Stewart-Warner 564447
S-102	3Z9903A-20.3	SWITCH: Rotary; rotor separate from stator; stator has 18 contacts, ceramic base; rotor has 5 spring contacts, ceramic base, held on shaft by a "C" clip; operated by control "A".	1st multiplier plate tank capacitor selecting switch	Centralab Z-6723 P. R. Mallory C-160015, TCM-18	Stewart-Warner 564530
S-103	3Z990A-20.2	SWITCH: Rotary; rotor separate from stator; stator has 18 contacts; ceramic base; rotor has 4 spring contacts, ceramic base, held on shaft by a "C" clip; operated by control "A".	2nd multiplier plate tank capacitor selecting switch	Centralab Z-6722 P. R. Mallory C-160014, TCM-18	Stewart-Warner 564540
S-104	3Z9849.83	SWITCH: Toggle, single pole; normally open; must be held "ON" to maintain contact; rated 40 amperes; body dimensions 1-1/8" x 21/32" x 5/8"; single hole mounting; solder lug terminals.	TEST switch	Cutler-Hammer 8817	Stewart-Warner 564741
S-105	3Z9825-62.173	SWITCH: Rotary; 3 position; two circuit; non-shorting; single deck; ceramic; overall dimensions 1.950" max. x 1-5/8" x 1-17/32"; single hole mounting by 3/8-32 threaded hub.	Metered circuit selector switch	Centralab 7373 P. R. Mallory RMC-1-GANG Oak Mfg. Co. 25636-H1C	Stewart-Warner 564747
S-106	3Z9825-62.177	SWITCH: Rotary; 3 position 6 circuit; shorting; two deck; ceramic; overall dimensions 1.950" max. x 1-5/8" x 2-3/16"; single hole mounting by 3/8-32 threaded hub.	CALIBRATE-TUNE-OPERATE switch	Centralab 6418 P. R. Mallory RMC-2-GANG Oak Mfg. Co. 25638-H2C	Stewart-Warner 564746

TABLE OF PARTS (Cont'd)

NOTE: Parts listed which are indicated by a # sign in column 2 are not available as spare parts and are listed for reference purposes only.

MODEL: RADIO TRANSMITTING SET AN 'ART-13A MAJOR ASSEMBLY: RADIO TRANSMITTER T-47A/ART-13

Reference Symbol	Army Stock Number Navy Stock Number British Ref. Number	Name of Part and Description	Function	Mfr. and Desig. or Standard Type	Cont. or Govt. Dwg. or Spec. No.
S-107	3Z9825-62.176	SWITCH: Rotary; 2 position; single deck; shorting; ceramic; overall dimensions 1.950" max. x 1-5/8" x 1-17/32"; single hole mounting by 3/8-32 threaded hub.	LOCAL-REMOTE switch	Centralab 7374 P. R. Mallory RMC-1-GANG Oak Mfg. Co. 25635-H1C	Stewart-Warner 564739
S-108	3Z9825-62.172	SWITCH: Rotary; 12 position; single deck; single circuit; non-shorting; ceramic; overall dimensions 1.950" max. x 1-7/32"; single hole mounting by 3/8-32 threaded hub.	CHANNEL selector switch	P. R. Mallory DWG. B-116833 Oak Mfg. Co. 25633-H1C	Stewart-Warner 564748
S-109	3Z9825-62.180	SWITCH: Rotary; 12 position; single circuit; one deck; no stop; 2-1/16" x 1-7/8" x 1-5/16"; two tapped No. 6-32 mounting holes, 1-3/4" between mtg/c.	Autotune motor control	Oak Mfg. Co. 27291-DH1	Stewart-Warner 564807
S-110	3Z9825-62.174	SWITCH: Rotary; 4 position; double deck; 3 circuit; shorting; ceramic; overall dimensions 1-7/8" x 1-5/8" x 2-3/16"; single hole mounting by a 3/8-32 threaded hub.	EMISSION selector switch	Centralab 7361 Oak Mfg. Co. 27131-H2C P. R. Mallory RMC-2-GANG	Stewart-Warner 564016
S-111	3Z9589-1	SWITCH: Toggle action leaf switch; S.P.D.T.; dimensions 1-5/16" x 3/8" x 3/8"; two mounting holes 0.128" dia; 0.375" between mtg/c; 3 solder lug terminals.	Rear motor control switch on multitrn Autotune Head	Guardian Elec. CXA-1043 Sheaffer Pen Co.	Stewart-Warner 564971
S-112	3Z9589	SWITCH: Leaf switch; S.P.S.T.; approx. 1-7/8" x 3/8" x 9/32"; two 0.128" mounting holes, 0.375" between mtg/c; two solder lug terminals.	Front motor control switch on multitrn Autotune Head	Sheaffer Pen Co. Aero Switch Co.	Stewart-Warner 565497
S-113	3Z9903A-45	SWITCH AND COIL ASSEMBLY: Complete with L-113, L-114, C-122, C-129, C-124, C-130, S-113A, S-113B, S-113C, S-113D, S-113E, S-113F, S-113G and S-113H; all parts assembled on mounting bracket and wired; operated by control C.	Antenna loading assembly	Soreng-Mangold A-11000A General Inst. W321-1 J. P. Seeburg Co. 186P-1	Stewart-Warner 564150
S-113D	#	SWITCH: S.P.S.T. leaf switch complete with bracket; 1-31/32" x 1-1/32" x 3/8"; two solder lug terminals; supplied as part of S-113.	Keying relay interlocking switch	Stewart-Warner 564177	Stewart-Warner 564177
S-114		SWITCH: Leaf type; consisting of S.P.D.T., S.P.S.T. normally open, S.P.S.T. normally closed; body dimensions 2-1/8" x 1-1/16" x 3/8"; mounting bracket has two No. 6-32 tapped holes, 0.406" between mtg/c; solder lug terminals; operated by control "A."	Low frequency, high frequency oscillator selecting switch	Guardian Elec. CXA-827 Aero Switch Co.	Stewart-Warner 564529
S-115	2C6900-47A/14	SWITCH: Leaf type; S.P.S.T. normally open; two 0.128" dia. mounting holes 0.375" between mtg/c; solder lug terminals; operated by control "A."	2nd multiplier cathode grounding switch	Guardian Elec. CXA-825 Aero Switch Co.	Stewart-Warner 564531

S-116	3Z9847-4.5	SWITCH; Vacuum; S.P.D.T.; part of relay K-102; 2-29 32" x 2-1 4" x 13 16"; set screw locking terminals.	Keying switch	JAN-S-57; Army Navy Type 1S21	Stewart-Warner 564647
T-101	2Z9634.38	TRANSFORMER, AUDIO; Modulation; 3 windings; pri. winding center tapped; D.C. resistance pri. (terminals 1-3) 270 ohms, D.C. resistance sec. No. 1 (terminals 4-5) 130 ohms; D.C. resistance sec. No. 2 (terminals 6-7) 170 ohms; hermetically sealed; case dimensions 4.362" x 3-55 64" x 3"; standoff porcelain insulated terminals with No. 8-32 bolts; four 0.218 mounting holes, 3-3 4" x 2-1 4" between mtg c.	Modulation transformer	Chicago Trans. 8800-B-O Standard Trans. 124A16 General Elec. M-7472230	Stewart-Warner 564890 ML-7470010-1
T-102	2C6900-47 C1	TRANSFORMER, R.F.; Meter coupling; iron core; single turn primary; single turn secondary; ceramic form, max. dimensions 2-5 32" x 2" dia.; secondary has flexible leads with lug terminals; single axial tapped No. 8-32 mounting holes.	Antenna ammeter coupling transformer	Stewart-Warner 564890 ML-7470010-1	Stewart-Warner 564890
V-101	2J837	TUBE: Beam Pentode.	High frequency oscillator tube	JAN Type 837	
V-102	2J1625	TUBE: Beam Pentode.	1st frequency multiplier tube	JAN Type 1625	
V-103	2J1625	TUBE: Same as V-102.	2nd frequency multiplier tube		
V-104	2J813	TUBE: Beam Pentode.	Power amplifier tube	JAN Type 813	
V-105	2J811	TUBE: Transmitting tube.	Modulator tube	JAN Type 811	
V-106	2J811	TUBE: Same as V-105.	Modulator tube		
X-101	2Z8677.20	SOCKET: Tube; 7 terminals; ceramic; 2-5 16" x 1-13 16" x 9 16"; 2 mounting slots in 11 64" x 17 64"; 1-25 32" between mtg c, solder lug terminals.	Socket for V-101 tube	Ucinite 115166 National Fab. 42C1D E. F. Johnson Co. 227N-BC	Stewart-Warner 564528
X-102	2Z8677.20	SOCKET: Same as X-101.	Socket for V-102 tube		
X-103	2Z8677.20	SOCKET: Same as X-101.	Socket for V-103 tube		
X-104	2Z8677.19	SOCKET: Tube; 7 terminals; ceramic; 2-5 8" x 2-5 8" x 9 16"; four 11/64" dia. mounting holes, 1-7 8" between mtg c.	Socket for V-104 tube	E. F. Johnson Co. 237N-BC Ucinite Co. 115175	Stewart-Warner 564404
X-105	2Z8762	SOCKET: Tube; 4 terminals; ceramic; 2-5 16" x 1-11 16" x 9 16"; two mounting slots 11 64" x 17 64"; 1-25 32" between mtg c.	Socket for V-105 tube	E. F. Johnson Co. 224N-BC Ucinite Co. 115158	Stewart-Warner 564432
X-106	2Z8762	SOCKET: Same as X-105.	Socket for V-106 tube		

TABLE OF PARTS (Cont'd)

NOTE: Parts listed which are indicated by a # sign in column 2 are not available as spare parts and are listed for reference purposes only.

MODEL: RADIO TRANSMITTING SET AN/ART-13A MAJOR ASSEMBLY: AUDIO AMPLIFIER

Reference Symbol	Army Stock Number Navy Stock Number British Ref. Number	Name of Part and Description	Function	Mfr. and Desig. or Standard Type	Cont. or Govt. Dwg. or Spec. No.
A-201	2C254	AUDIO AMPLIFIER ASSEMBLY: Furnished as a complete unit minus tubes.	Audio amplifier section	Stewart-Warner 564250 General Elec. ML-7765416-1	Stewart-Warner 564250
C-201	3DB20-19	CAPACITOR: Electrolytic; 20 microfarads - 10% + 65%; 50 volts DCW; sealed case 1-13/16" x 1" x 3/4"; two mounting feet each with 3/16" dia. holes spaced 2-1/8" between mtg/c; 2 solder lug terminals spaced 1" apart.	Microphone filter	P. R. Mallory 95117 Cornell-Dubilier AVI-10051 Sprague Elec. S 4979	Stewart-Warner 564088
C-202	3DA50-161	CAPACITOR: Same as C-201.	Audio amplifier cathode by-pass	Cornell-Dubilier MC-8G06 John E. Fast Sprague Elec. Co. TYC-GS5	Stewart-Warner 564086
C-203		CAPACITOR: Fixed; paper; 50,000 microfarads ± 20%; 600 volts DCW; liquid filled; hermetically sealed; tubular metal container 1-1/4" x 5/8" dia.; 1-3/4" axial wire leads; single mounting bracket with 2-5/32" holes.	Audio amplifier screen by-pass	Sangamo Elec. Co. BEW 15260-B10 Cornell-Dubilier 140LS	Stewart-Warner 564083
C-204	3DA6-21	CAPACITOR: Fixed; mica; 6000 microfarads ± 10%; 750 volts DCW; case 1-13/64" x 1" x 3/8"; two solder lug terminals each with a 0.149" dia. hole spaced 1-3/4" between mtg/c; 2 mounting holes 23/32" between mtg/c.	Audio driver grid coupling	Sangamo Elec. Co. BEW 15210-B10 Cornell-Dubilier 140LS	Stewart-Warner 564081
C-205	3DA1-104	CAPACITOR: Fixed; mica; 1000 microfarads ± 10%; 750 volts DCW; case 1-13/64" x 3/8"; 2 solder lug terminals each with a 0.147" dia. hole spaced 1-3/4" between mtg/c; two mounting holes 23/32" between mtg/c.	Audio amplifier plate decoupling	Sangamo Elec. BEW-15230 B10 Cornell-Dubilier 140	Stewart-Warner 564082
C-206	3DA3-58	CAPACITOR: Fixed; mica; 3,000 microfarads ± 10%; 750 volts DCW; case 1-13/64" x 3/8"; two solder lug terminals each with a 0.147" dia. hole spaced 1-3/4" between mtg/c; two mounting holes 23/32" between mtg/c.	Audio driver output coupling		
C-207	3DA50-161	CAPACITOR: Same as C-201.	Audio driver cathode by-pass		
C-208	3DA50-161	CAPACITOR: Same as C-201.	Sidestone Amplifier cathode coupling		
C-209	3DA10-159	CAPACITOR: Fixed; paper; 10,000 microfarads - 20% + 60%; 400 volts DCW; oil impregnated; molded; 53/64" x 53/64" x 11/32"; 1-1/4" wire leads.	Modulator Grid radio frequency by-pass	AWS Type CN35A103	
C-210	3DA10-159	CAPACITOR: Same as C-209.	Modulator Grid radio frequency by-pass		
E-201	2Z9406.133	RESISTOR-BOARD: Less resistors; less mounting stand-off; with solder lug terminals; 1-7/8" x 7/8" x 1/8"; bakelite.	Resistor Board for R201, R202, R203, R204	H. B. Jones 6-1	Stewart-Warner 564054

E-202	2Z9410.93	RESISTOR-BOARD: Less resistors; with solder lug terminals; 1-5/8" x 1-1/4" x 1/8"; bakelite.	Resistor Board for R208, R209, R210, R211, R212	H. B. Jones 10-1	Stewart-Warner 564053
E-203	2Z5786.36	KNOB: Brass 3/8" x 7/16" dia.; screw driver slot for turning; 2 tapped No. 6-40 mounting holes.	Knob for S-202 switch	Dunwell Screw Lincoln Mfg. 10388 Selflock Co.	Stewart-Warner 564011
E-204	6Z4914	GROMMET: Same as E-124; two used.	Cover for the four electrolytic condensers	Aluminum Goods 04407	Stewart-Warner 564073
H-201	#	COVER: Aluminum; 2.636" x 2-5/8" x 1-9/16"; two 0.156" mounting holes spaced 2.125" between mtg./c.			
H-202	#	STAND-OFF: Aluminum; 2.625 x 1/4" x 1/4"; single, tapped No. 6-32 mounting hole at each end, 11/32" deep; two tapped No. 6-32 condenser mounting holes 1-1/32" between mtg./c.	Electrolytic condenser mounting post	Lincoln Mfg. 10390 Dunwell Scr. Prod.	Stewart-Warner 564044
H-203	#	STAND-OFF: Same as H-202.	Electrolytic condenser mounting post		
H-204	#	STAND-OFF: Aluminum; 7/16" x 1/4" hex; axial, tapped No. 6-32 mounting hole.	Resistor board mounting	Lincoln Mfg. 10392 Dunwell Scr. Prod.	Stewart-Warner 564048
H-205	#	STAND-OFF: Same as H-204.	Resistor board mounting		
H-206	#	STAND-OFF: Aluminum; 1/2" x 1/2" x 3/8"; one tapped No. 6-32, plug, mounting hole; one tapped No. 8-32 mounting hole.	P-201 connector mounting	Stewart Die Cast. 564042 Dunwell Scr. Prod.	Stewart-Warner 564042
H-207	#	STAND-OFF: Aluminum; 1.781" x 5/8" x 1/4"; two tapped No. 6-32 mounting holes.	P-201 connector mounting	Stewart Die Cast. 564043 Dunwell Scr. Prod.	Stewart-Warner 564043
H-208	#	BRACKET: Steel; 3-11/32" x 3/4" x 5/8"; two tapped No. 6-32 mounting holes on one end; two 0.218 mounting holes for two H-210 nuts on the other end.	Switch mounting bracket	Crescent Tool & Die Co.	Stewart-Warner 564051
H-209	#	SCREW: No. 6-40 x 1/8" cup point set screw; two used.	For S-202 switch knob	Supplies Inc. Bristol Co.	Stewart-Warner 564097
H-210	#	NUT: Special No. 6-32 stop nut; two used.	Used on switch bracket H-208	Patton McGuyer 1013 Elastic Stop Nut	Stewart-Warner 564012
H-211	#	NUT: 3/8-32 thread; hexagon; 1/2" x 3/32".	S-202 rotary switch mounting	Pheoll Mfg. United Bolt Co.	Stewart-Warner 564027
H-212	#	NUT: 15/32-32 thread; hexagon; 9/16" x 3/32".	S-201 toggle switch mounting nut	United Bolt Co. Lincoln Mfg. Co.	Stewart-Warner 564094
P-201	2Z7122.10	CONNECTOR: Male; 12 prongs; molded case; case dimensions 1-1/4" x 15/16" x 7/16".	Audio amplifier unit connecting plug	H. B. Jones P-312-AB A. W. Franklin Co.	Stewart-Warner 564084
R-201	3RC30BF221J	RESISTOR: Fixed; carbon; 220 ohms $\pm 5\%$; 1 watt; 1-1/2" axial leads; insulated; maximum dimensions 0.718" x 0.280" dia.	Microphone current limiting	JAN Type RC30BF221J	
R-202	3RC30BF101J	RESISTOR: Fixed; carbon; 100 ohms $\pm 5\%$; 1 watt; 1-1/2" axial leads; insulated; maximum dimensions 0.718" x 0.280" dia.	Microphone current limiting	JAN Type RC30BF101J	

TABLE OF PARTS (Cont'd)

NOTE: Parts listed which are indicated by a # sign in column 2 are not available as spare parts and are listed for reference purposes only.

MODEL: RADIO TRANSMITTING SET AN/ART-13A

MAJOR ASSEMBLY: AUDIO AMPLIFIER

Reference Symbol	Army Stock Number Navy Stock Number British Ref. Number	Name of Part and Description	Function	Mfr. and Desig. or Standard Type	Cont. or Govt. Dwg. or Spec. No.
R-203	3RC21BF472J	RESISTOR: Fixed; carbon; 4700 ohms \pm 5%; 1/2 watt; 1-1/2" axial leads; insulated; maximum dimensions 0.718" x 0.280" dia.	Microphone output coupling	JAN Type RC21BF472J	
R-204	3RC30BF221J	RESISTOR: Same as R-201.	T-201 primary terminating resistor		
R-205	3RC21BF474K	RESISTOR: Fixed; carbon; insulated; 470,000 ohms \pm 10%; 1/2 watt; 1-1/2" axial leads; max. dimensions 0.655" x 0.249" dia.	Audio amplifier grid	JAN Type RC21BF474K	
R-206	3Z6004B2	RESISTOR: Fixed; 42 ohms \pm 10%; 10 watts in open air; wire wound; vitreous enameled; max. current 490 milliamperes; max. voltage 20.6 volts; two solder lugs each with a 1/8" dia. hole on 1-7/16" mtg/c; overall dimensions 1-3/4" x 1 1/16" x 3/8"; 3/16" dia. axial mounting hole.	Audio amplifier filament current	Ohmite Mfg. Co. 10 W. Browndevil Federal Electric 126 Ward-Leonard 1-3/4" Z-42 I.R.C., AB-3-B	Stewart-Warner 564380
R-207	3ZK6220-30	RESISTOR: Fixed; carbon or wire wound; 2,200 ohms \pm 10%; 1 watt; insulated; 1/2" axial leads; max. inductance 8.0 microhenries; dimensions 1.280" x 0.310" dia.	Audio amplifier cathode	I.R.C. BW-1 A. Bradley GB1	Stewart-Warner 564063
R-208		RESISTOR: Fixed; carbon; 1 megohm \pm 10%; 1/2 watt; insulated; 1-1/2" axial leads; max. dimensions 0.655" x 0.249" dia.	Audio amplifier screen	JAN Type RC21BF105K	
R-209	3RC21BF224K	RESISTOR: Fixed; carbon; 220,000 ohms \pm 10%; 1/2 watt; 1-1/2" axial leads; max. dimensions 0.655" x 0.249" dia.	Audio amplifier plate	JAN Type RC21BF224K	
R-210	3RC21BF474K	RESISTOR: Same as R-205.	Audio driver grid		
R-211	3RC21BF104J	RESISTOR: Fixed; carbon; 100,000 ohms \pm 5%; 1/2 watt; insulated; 1-1/2" axial leads; max. dimensions 0.655" x 0.249" dia.	Sidetone amplifier grid	JAN Type RC21BF104J	
R-212	3RC21BF474J	RESISTOR: Fixed; carbon; 470,000 ohms \pm 5%; 1/2 watt; insulated; 1-1/2" axial leads; max. dimensions 0.655" x 0.249" dia.	Sidetone amplifier grid coupling	JAN Type 21BF474J	
R-213		RESISTOR: Fixed; carbon or wire wound; 750,000 ohms \pm 5%; 1/2 watt; insulated; 1-1/2" axial leads; max. dimensions 0.655" x 0.249" dia.	Audio driver plate decoupling	I.R.C. BT 1/2 A. Bradley EB Speer S1-1/2 Stackpole CM-1/2 Erie 524	Stewart-Warner 564069
R-214	3Z6025-76	RESISTOR: Fixed; carbon or wire wound; 250 ohms \pm 10%; 1 watt; insulated; 1-1/2" axial leads; max. inductance 8.0 microhenries; max. dimensions 1.280" x 0.310" dia.	Audio driver cathode	I.R.C. BW1 A. Bradley GB-1	Stewart-Warner 564062

R-215	3Z6025-76	RESISTOR: Same as R-214.	Sidetone amplifier cathode	I.R.C. BW 1/2 A. Bradley GB-1/2	Stewart-Warner 564059
R-216		RESISTOR: Fixed; carbon or wire wound; 220 ohms $\pm 10\%$; 1/2 watt; insulated; 1-1/2" axial leads; max. inductance 4.0 microhenries; max. dimensions 0.655" x 0.249" dia.	T-201 primary current limiting		
S-201	3Z9857-40	SWITCH: Toggle; D.P.D.T.; 1 ampere 250 volts D.C., or 3 ampere 125 volts D.C.; single hole mounting; overall dimensions 1-9/16" x 5/8" thk.	Microphone circuit selector switch	Cutler-Hammer 8363 DP-DT Arrow-Hart & Hageman Co. 20905-JD-GH General-Electric K-7890670 P-1	Stewart-Warner 564087
S-202	3Z9825-55.66	SWITCH: Rotary; 6 position; 1 pole; shorting type; silver plated contacts; overall dimensions 1-1/4" dia. x 1-9/16"; single hole mounting.	Sidetone amplifier output control switch	Mallory 3116 B-116839 Chgo. Tel. Sup. Oak Mossman	Stewart-Warner 564089
T-201	2Z9631-93	TRANSFORMER, AUDIO: Input; two windings; D.C. resistance primary 10 ohms; secondary 4,000 ohms; max. D.C. current primary one milliampere; shielded; max. case dimensions 2-3/4" x 2-3/32" x 1-25/32"; hermetically sealed; 300-4000 C.P.S.; four 6-32 mounting studs; three solder lug terminals; electrostatic shield.	Audio amplifier input coupling	Stancor Chicago Trans. 10160-0 General-Electric M-7472065	Stewart-Warner 564394
T-202	2Z9636-78	TRANSFORMER, AUDIO: Interstage driver; 3 windings; D.C. resistance primary max. 300 ohms; D.C. resistance each secondary max. 100 ohms; max. D.C. current primary 30 milliamperes 300-4,000 C.P.S.; max. dimensions 2-3/4" x 2-3/32" x 1-25/32"; four No. 6-32 mounting studs; 6 solder lug terminals; electrostatic shield; shielded.	Audio driver output coupling	Stancor Chicago Transf. 10170-0 General-Electric M-7472064	Stewart-Warner 564392
T-203	2Z932-327	TRANSFORMER, AUDIO: Sidetone output; two windings; five taps on secondary; D.C. resistance primary 300 ohms; secondary max. 20 ohms; max. primary current 30 milliamperes D.C.; shielded; 300-4,000 C.P.S.; max. case dimensions 2-3/4" x 2-3/32" x 1-25/32"; four No. 6-32 mounting studs; eight solder lug terminals; secondary grounded to case; electrostatic shield.	Sidetone amplifier output coupling	Stancor Chicago Transf. 10180-0 General-Electric M-7472063	Stewart-Warner 564393
V-201	2J12S7	TUBE: Pentode amplifier.	Audio pre-amplifier tube	JAN Type 12S7	
V-202	2J6V6GT	TUBE: Beam power tube.	Audio driver tube	JAN Type 6V6GT	
V-203	2J6V6GT	TUBE: Same as V-202.	Sidetone amplifier		
X-201	2Z8678-187	SOCKET: octal; 8 prongs; black bakelite; mounting plate has two 5/32" dia. holes, 1.312" between mtg/c.	Socket for V-202 tube	Amer. Phenolic 88-8M	Stewart-Warner 564085
X-202	2Z8678-187	SOCKET: Same as X-201.	Socket for V-202 tube		
X-203	2Z8678-187	SOCKET: Same as X-201.	Socket for V-203 tube		

TABLE OF PARTS (Cont'd)

NOTE: Parts listed which are indicated by a # sign in column 2 are not available as spare parts and are listed for reference purposes only.

MODEL: RADIO TRANSMITTING SET AN ART-13A

MAJOR ASSEMBLY: CONTROL UNIT C-87/ART-13A

Reference Symbol	Army Stock Number Navy Stock Number British Ref. Number	Name of Part and Description	Function	Mfr. and Desig. or Standard Type	Cont. or Govt. Dwg. or Spec. No.
E-601	2ZK 5991-7	RECEPTACLE: Ruby jewel lens; 3/8" I.D. miniature bayonet socket; two solder lug terminals; overall dimensions 2-1/4" x 1-5/16" dia. Same as E-102.	Pilot's control box pilot light receptacle	Drake Mfg. Cat. No. 80 Dial Lite Co. DVT-90SAD RED	Stewart-Warner 564021
E-602	2Z5843.12	KNOB: Same as E-126.	Channel selector switch knob		
E-603	2Z5843.12	KNOB: Same as E-126.	Emission selector switch knob		
I-601	2Z5938	LAMP: Bayonet base; 3/8" dia.; clear glass; overall dimensions 1-1/8" x 7/16" dia. Same as I-101.	Indicator lamp—pilot's control box	General-Electric 3-1/4 Cat. No. 313	Stewart-Warner 564022
J-601	2Z8697.3	PLUG: Male; 27 contacts; wall mounting by four 0.144" dia. holes; 1.259" between mtg/c; all contacts rated 10 amperes; overall dimensions 1-5/8" x 1-5/8" x 29/32" thk; threads for locking female plug.	Pilot's control box connecting plug receptacle	Cannon Elec. NK-27-32S-3	Stewart-Warner 564020
J-602	2Z5533A	JACK: Midget; 3 circuit; 3 solder lug terminals; overall dimensions 1-3/16" x 29/32" dia.; to fit plug with 3/16" bar-rel. Same as J-102.	Pilot's microphone cord plug receptacle	National Fab. JK-33A Mallory SC1A	Stewart-Warner 564023
S-601	3Z9825-62.178	SWITCH: Rotary; one deck; ceramic insulation; 11 position; single hole mounting; overall dimension 1-7/8" x 1-5/8" x 1-21/32".	Pilot's channel selector switch	Oak Mfg. Co. 27130-H1C Centralab 6414 Mallory RMC-1-GANG	Stewart-Warner 564015
S-602	3Z9825-62.174	SWITCH: Rotary; two decks; ceramic insulation; 4 position; single hole mounting; 3 circuit; overall dimensions 1-7/8" x 1-5/8" x 2-5/16" thk. Same as S-110.	Pilot's emission selector switch	Centralab 7361 Oak Mfg. Co. 27131-H2C	Stewart-Warner 564016
S-603	3Z3602-6	SWITCH: Telegraph key; plunger type; chassis mounting; overall dimensions 2-59/64" x 1-13/32" x 1-5/16"; two threaded mounting holes No. 4-40, 1-1/2" between mtg/c; solder lug terminals.	Pilot's telegraph key	Guardian Elec. G-36455	Stewart-Warner 564019

CONTROL PANEL C-405/A

E2801		KNOB: bar; black plastic; for 1/4" dia. shaft; two 8-32 set screws; marked with white arrow; 1-1/4" long x 11/16" high.	Channel selector switch knob	Telephonics Corp. 35025	47A40527
E2802		SOCKET: lamp; screw base; 7/16" mtg. hole; accommodates 319, 320 or 321 G.E. lamp.	Receptacle for indicator lamp	Birdwell and McAlister 17L9A	
E2803		KNOB: Same as E2801.	Emission selector switch knob		

49C12551-2

ADAPTER: 2-5/8" long, 1" wide, .064" thick; aluminum plate with two each .180" dia. holes 2-1/4" apart for bolting to the control panel and two each quarter-turn fasteners for installing the adapted panel in the rack; two each are required per panel.

LAMP: incandescent; 28-volt; 15/16" long x 0.562" dia; 0.035 amperes; bulb T-1-3/4; filament C-21; special screw base to fit E2802.

SWITCH: rotary; single-pole; 11-position; 1 section; ceramic wafer; 3/8" hole for mounting; same as S601.

SWITCH: rotary; 3-pole; 4-position; 2 sections; ceramic wafers; 1-3/4" deep x 1-7/8" long x 1-1/2" wide; 3/8" dia. hole for mounting.

G.E. No. 321

Oak Mfg. Co.
34941-H1C

Oak Mfg. Co.
34942-H2C

47B40536

E2804

I2801

S2801

S2802

Indicator lamp

Channel selector switch

Emission selector switch

MAJOR ASSEMBLY: ANTENNA CAPACITOR UNIT CU-24/ART-13A

C-1101 3D9025-52 CAPACITOR: Fixed; sulphur; 25 micromicrofarads 10% test voltage 10,000 volts peak; overall dimensions 3-5/8" x 2-13/16" x 2"; two 0.193" dia. mounting holes 2-7/16" between mtg/c; one push type binding post terminal; case grounded. Solar Mfg. XYAW10-425-10 Stewart-Warner 564004
Aerovox 1860-201
General-Electric 29 F 15

C-1102 3D9025-52 CAPACITOR: Same as C-1101. Antenna shunt capacitor

C-1103 3D9025-52 CAPACITOR: Same as C-1101. Antenna shunt capacitor

H-1101 # PLATE MOUNTING: Aluminum; 5" x 4-1/8" x 1/16". Mounting plate for C-1101, C-1102, C-1103 Stewart-Warner 564003
General-Electric K-7891085

MAJOR ASSEMBLY: M.C.W.-C.F.I.

A-2201 3F2448-2 M.C.W.-C.F.I.: Furnished as a complete assembly less tubes and crystal; overall dimensions 5-7/8" x 3-3/8" x 5"; single plug-in connector. Crystal frequency standard and M.C.W. oscillator Stewart-Warner 564400
General-Electric ML-7765405-1

C-2201 3DA6-77 CAPACITOR: Fixed; oil impregnated paper; 6,000 micro-microfarads +60% -20%; 600 volts DCW; max. dimensions 53/64" x 53/64" x 11/32"; moulded; 1-1/4" wire leads. Calib. osc. tripler plate coupling JAN Type CN35A602

C-2202 3DA6-77 CAPACITOR: Same as C-2201. Calib. osc. tripler grid coupling Stewart-Warner 564400

C-2203 3DA6-77 CAPACITOR: Same as C-2201. Calib. osc. mixer grid coupling General-Electric ML-7765405-1

C-2204 3K2520143 CAPACITOR: Fixed; silver mica; 200 micromicrofarads; ±5%; 500 volts DCW; 1-1/16" x 9/16" x 3/16"; color of case, red; 1-1/4" wire leads. Calib. osc. det. grid coupling Sickles SD-3069 J. E. Fast Cornell-Dubilier 2RS Stewart-Warner 564646

C-2205 3K2010021 CAPACITOR: Fixed; mica; 10 micromicrofarads ±10%; 500 volts DCW; moulded case; max. dimensions 51/64" x 15/32" x 7/32"; 1-1/8" wire leads. Calib. osc. input to H.F.O. AWS Type CM20B100K

TABLE OF PARTS (Cont'd)

NOTE: Parts listed which are indicated by a # sign in column 2 are not available as spare parts and are listed for reference purposes only.

MODEL: RADIO TRANSMITTING SET AN ART-13A

MAJOR ASSEMBLY: M.C.W.-C.F.I.

Reference Symbol	Army Stock Number Navy Stock Number British Ref. Number	Name of Part and Description	Function	Mfr. and Desig. or Standard Type	Cont. or Govt. Dug. or Spec. No.
C-2206	3K2010021	CAPACITOR: Same as C-2205.	Calib. osc. input to L.F.O.		
C-2207	3DA50-99.1	CAPACITOR: Fixed; paper; 50,000 microfarads $\pm 10\%$; 600 volts DCW; liquid impregnated; hermetically sealed; metal container 1-1/2" x 5/8" dia.; axial terminal lugs 7/32" long; single mounting bracket with two 5/32" dia. holes.	Calib. osc. plate decoupling capacitor	Solar Mfg. Co. CN-35A 103 Micamold Cornell-Dubilier MC8B55	Stewart-Warner 564569
C-2208	3DA50-99.1	CAPACITOR: Same as C-2207.	Calib. osc. mixer screen decoupling		
C-2209	3DA50-99.1	CAPACITOR: Same as C-2207.	Calif. osc. output coupling		
C-2210	3DA50-99.1	CAPACITOR: Same as C-2207.	Audio osc. grid tank		
C-2211	3DA500-30	CAPACITOR: Fixed; paper; 500,000 microfarads $\pm 20\%$; 600 volts DCW; metal case 1-13/16" x 1" x 7/8"; two mounting feet each with a 3/16" dia. hole, 2-1/8" between mtg/c; two solder lug terminals.	High voltage supply filter	Solar XDMRW 65-20 Cornell-Dubilier DYR 6050 J. E. Fast	Stewart-Warner 564589
C-2212-A	3DA100-133.3	CAPACITOR: Fixed; paper; two identical sections C-2212-A, C-2212-B; each 100,000 microfarads $\pm 10\%$; 600 volts DCW; oil impregnated; both inclosed in metal case 1-13/16" x 13/16" x 13/16" two mounting feet each with a 3/16" dia. hole; 3 solder lug terminals, center one common and marked C.	Audio osc. plate blocking	J. E. Fast A8085 Sprague Spec. P 13000 J. E. Fast	Stewart-Warner 564588
C-2212-B	3DA100-133.3	CAPACITOR: Same as C-2212-A.	Audio osc. tank tuning		
C-2213	3K2030030	CAPACITOR: Fixed; silver mica; 30 microfarads $\pm 5\%$; 500 volts DCW; case color, red; max. dimensions 51/64" x 15/32" x 7/32"; 1-1/8" wire leads.	Osc. feedback	JAN Type CM20C300J	
C-2214	3K3547224	CAPACITOR: Fixed; mica; 4,700 microfarads $\pm 20\%$; 500 volts DCW; max. dimensions 53/64" x 53/64" x 11/32"; 1-1/8" wire leads.	V-2203 audio grid capacitor	JAN Type CM35B472M	
E-2201	2Z9430-3	TERMINAL BOARD: With mounting brackets and solder lug terminals; minus resistors and capacitors; bakelite; 4-5/8" x 1-1/4" x 1/8".	Supports resistors R-2202, R-2215 and capacitors C-2201, C-2206.	Cinch Mfg. 7414 Anchor Radio	Stewart-Warner 564581
H-2201	#	SPRING: Crystal hold-down spring; spring copper or brass; two 0.142" dia. mtg. holes.	Crystal holder	Wallace Barnes	Stewart-Warner 564659
L-2201	3C317-32	COIL, AUDIO OSC. REACTOR: Single winding; one tap; metal case, 2-3/8" x 1-11/16" x 1-3/8" hermetically sealed; two 3/16" dia. mounting holes 2.0" between mtg/c; three solder lug terminals.	Audio osc. grid tank inductor	Chicago Transf. 8660-A-0 Stancor 12405 General-Electric M-7472242	Stewart-Warner 564652

P-2201	2Z7228.4	CONNECTOR Male: 8 prong; molded case; $1\frac{1}{4}$ " x $1\frac{1}{8}$ " x $\frac{1}{8}$ "; two mounting feet each with a 0.146" dia. hole; prongs numbered.	Unit connecting plug	H. B. Jones P-308-AB.W1	Stewart-Warner 564568
R-2201	3Z7015-7	RHEOSTAT: Wire wound; 2 to 15 ohms; min. tolerance ± 2 ohms; max. tolerance ± 3 ohms; overall dimensions $1\frac{1}{4}$ " x $\frac{3}{8}$ " x $\frac{3}{8}$ "; $\frac{3}{16}$ " x $\frac{1}{8}$ " screw driver adjustment slot; single solder lug terminal; one end of element grounded to frame; mounting plate has two 0.136" dia holes 1" between mtg/c.	Audio osc. output control	Wirt Co. 2912,807	Stewart-Warner 564567
R-2202	3RC21BF104K	RESISTOR: Fixed; 100,000 ohms $\pm 10\%$; $\frac{1}{2}$ watt; carbon; insulated; max. dimensions 0.655" x 0.249" dia.; $1\frac{1}{2}$ " axial wire leads.	Calib. osc. plate decoupling	JAN Type RC21BF104K	
R-2203	3RC21BF473K	RESISTOR: Fixed; 47,000 ohms $\pm 10\%$; $\frac{1}{2}$ watt; carbon; insulated; max. dimensions 0.655" x 0.249" dia.; $1\frac{1}{2}$ " axial wire leads.	Calib. osc. tripler grid	JAN Type RC21BF473K	
R-2204	3RC21BF154K	RESISTOR: Fixed; 150,000 ohms $\pm 10\%$; $\frac{1}{2}$ watt; carbon; insulated; max. dimensions 0.655" x 0.249" dia.; $1\frac{1}{2}$ " axial wire leads.	Audio osc. grid coupling	JAN Type RC21BF154K	
R-2205	3RC21BF473K	RESISTOR: Fixed; 47,000 ohms $\pm 10\%$; $\frac{1}{2}$ watt; carbon; insulated; max. dimensions 0.655" x 0.249" dia.; $1\frac{1}{2}$ " axial wire leads.	Calib. osc. mixer inject. grid	JAN Type RC21BF473K	
R-2206	3RC21BF473K	RESISTOR: Same as R-2205.	Calib. osc. mixer cont. grid		Stewart-Warner 564591
R-2207	3Z4885	RESISTOR: Fixed; wire wound; 85 ohms $\pm 2.5\%$; 10 watts in open air; max. voltage 29.1 volts; max. current 343 milliamperes; vitreous enameled; two solder lug terminals each with a $\frac{1}{8}$ " dia. hole 1-17/16" between mtg/c; $\frac{3}{8}$ " dia. axial opening through resistor; overall dimensions $1\frac{3}{4}$ " x $1\frac{1}{8}$ " x $\frac{3}{8}$ ".	Calib. osc. mixer filament dropping	Federal Elec. 127 Ward-Leonard $1\frac{3}{4}$ " Z 85 Ohmite 19167	
R-2208	3RC21BF333K	RESISTOR: Fixed; 33,000 ohms $\pm 10\%$; $\frac{1}{2}$ watt; carbon; insulated; max. dimensions 0.655" x 0.249" dia.; $1\frac{1}{2}$ " axial wire leads.	Calib. osc. plate decoupling	JAN Type RC21BF333K	
R-2209	3RC31BF153K	RESISTOR: Fixed; 15,000 ohms $\pm 10\%$; 1 watt; carbon; insulated; max. dimensions 1.280" x 0.310" dia.; $1\frac{1}{2}$ " axial wire leads.	Calib. osc. screen dropping	JAN Type RC31BF153K	
R-2210	3Z5550-19	RESISTOR: Fixed; 15,000 ohms $\pm 10\%$; rating 4 watts in open air (10 watt size); wire wound; vitreous enameled; two solder lug terminals; $\frac{3}{8}$ " dia. axial mounting hole through resistor.	Calib. osc. H.V. dropping resistor	Federal Elec. 128 Ward-Leonard $1\frac{3}{4}$ " Z 15,000	Stewart-Warner 564590
R-2211	3RC31BF224K	RESISTOR: Fixed; 220,000 ohms $\pm 10\%$; $\frac{1}{2}$ watt; carbon; insulated; max. dimensions 0.655" x 0.249" dia.; $1\frac{1}{2}$ " axial wire leads. Same as R-209.	Audio osc. high voltage dropping	JAN Type RC31BF224K	
R-2212	3RC21BF683K	RESISTOR: Fixed; composition; 68,000 ohms $\pm 10\%$; $\frac{1}{2}$ watt.	Audio osc. (V2203) high voltage bleeder	JAN Type 3RC21BF683K	
R-2213	3RC21BF474K	RESISTOR: Fixed; 470,000 ohms $\pm 10\%$; $\frac{1}{2}$ watt; carbon; insulated; max. dimensions 0.655" x 0.249" dia.; $1\frac{1}{2}$ " axial wire leads. Same as R-205.	Calib. osc. det. grid	JAN Type RC21BF474K	
R-2214	3RC21BF474K	RESISTOR: Same as R-2213.	Calib. osc. det. plate decoupling		
R-2215	3RC21BF222J	RESISTOR: Fixed; 2,200 ohms $\pm 5\%$; $\frac{1}{2}$ watt; carbon; insulated; max. dimensions 0.655" x 0.249" dia.; $1\frac{1}{2}$ " axial wire leads.	Audio osc. output loading	JAN Type RC21BF222J	

TABLE OF PARTS (Cont'd)

NOTE: Parts listed which are indicated by a # sign in column 2 are not available as spare parts and are listed for reference purposes only.

MODEL: RADIO TRANSMITTING SET AN ART-13A

MAJOR ASSEMBLY: M.C.W.-C.F.I.

Reference Symbol	Army Stock Number Navy Stock Number British Ref. Number	Name of Part and Description	Function	Mfr. and Desig. or Standard Type	Cont. or Govt. Dwg. or Spec. No.
R-2216	3RC21BF154K	RESISTOR: Same as R-2204.	Calib. osc. grid resistor		
R-2217	3RC30BF221J	RESISTOR: Same as R-201.	V-2202 and V-2203 biasing resistor		
V-2201	2J12SL7GT	TUBE: Dual triode; 12SL7GT.	Calib. osc. crystal osc., tripler	JAN Type 12SL7GT	
V-2202	2J12SA7	TUBE: Pentode converter; 12SA7.	Calib. osc., mixer	JAN Type 12SA7	
V-2203	2J12SL7GT	TUBE: Same as V-2201.	Calib. osc. det., audio osc.		
X-2201	2Z8678.187	SOCKET: Tube; octal; 8 contacts; black bakelite; 1-5/8" x 1-3/16" x 13/16"; mounting plate with two 5/32" dia. holes, 1.312" between mtg/c. Same as X-201.	Socket for V-2201 tube	Amer. Phenolic 88-8M	Stewart-Warner 564085
X-2202	2Z8678.187	SOCKET: Same as X-2201.	Socket for V-2202 tube		
X-2203	2Z8678.187	SOCKET: Same as X-2201.	Socket for V-2203 tube		
X-2204	2Z8672.8	SOCKET: Crystal; two terminals; phenolic material; 13/16" x 35/64" x 5/16" solder lug terminals.	Socket for Y-2201 crystal	Cinch 9816 Cannon Elec. Co. WK-C3-32S	Stewart-Warner 564657
Y-2201		CRYSTAL: 200 Kc; two prongs; plug in type; 1-1/8" x 1-1/16" x 7/16".	Calib. osc. frequency control	Supplied by the government	Sig C Spec 71-3021
Z-2201-A	3C323-114B	COIL: Iron core tuned; complete with two, 250 micro-microfarads, silver mica capacitors; tuning range 190-210 Kc; shielded; can size 2-17/32" x 1-9/16" x 1-1/8"; two mounting studs; two wire leads, one 4-1/2" red, one 5-1/2" black with orange tracer; Z-2201-B also assembled in this can.	Calib. osc. crystal osc. grid tank	Aladdin Radio 49-159 F. W. Suckles 30-5345	Stewart-Warner 564654
Z-2201-B	3C323-114B	COIL: Iron core tuned; complete with a 1500 micro-microfarad silver mica capacitor; tuning range 47 to 53 Kc; shielded; can size 2-17/32" x 1-9/16" x 1-1/8"; two No. 6-32 mounting studs; two wire leads, one 3" blue with white tracer, one 5-1/2" orange with green and white tracer; Z-2201-A also assembled in this can.	Calib. osc. det. cathode tank	Aladdin Radio 49-159 F. W. Suckles 30-5345	Stewart-Warner 564654
Z-2202-A	3C323-114A	COIL: Iron core tuned; complete with a 1,000 micro-microfarad, silver mica capacitor; tuning range 142-158 Kc; shielded; can size 2-17/32" x 1-9/16" x 1-1/8"; two mounting studs; one 4-1/2" wire lead orange; one 7" wire lead red with green tracer, which is common with Z-2202-B and is also assembled in this can.	Calib. osc. tripler plate tank	Aladdin Radio 49-160 E. I. Guthman 30-5346	Stewart-Warner 564655

Stewart-Warner
564655Aladdin Radio
49-160
E. I. Guthman
30-5346

Calib. osc. mixer tank

COIL: Iron core tuned; complete with a 1,500 microfarad silver mica capacitor, tuning range 47-53 Kc; shielded; can size 2-17/32" x 1-9/16" x 1-1/8"; two mounting studs; one 4-1/2" wire lead black with orange tracer; one 7" wire lead red with green tracer, which is common with Z-2202-A and is also assembled in this can.

Z-2202-B 3C323-114A

MAJOR ASSEMBLY: LOW FREQUENCY OSCILLATOR O-17/ART-13A

Stewart-Warner
564900Stewart-Warner
564900
General-Electric
ML-7662998-1200-600 Kc oscillator
unit

LOW FREQUENCY OSCILLATOR: Furnished as a complete unit.

A-2601 2C2710-17

Stewart-Warner
564522Sangamo Electric
BEW-15220-B20JAN-1625 screen grid
by-pass

CAPACITOR: Fixed; mica; 2,000 microfarads $\pm 20\%$; 750 volts DCW; two solder lug terminals; 2-1/4" x 1" x 3/8"; two mounting holes 23/32" between mtg./c. Same as C-109.

C-2601 3DA2-110.2

JAN Type
CM20B470MJAN-1625 cathode
coupling capacitor

CAPACITOR: Fixed; mica; 47 microfarads $\pm 20\%$; 500 volts DCW; molded; max. dimensions 51/64" x 15/32" x 7/32"; 1-1/8" wire leads.

C-2602 3K2047024

JAN Type
CC45HG301GJAN-1625 grid
coupling capacitor

CAPACITOR: Fixed; ceramic; 300 microfarads $\pm 2\%$; working voltage 500 volts rms. at 1.5 mc.; tubular ceramic 1.8" x 0.280" dia.; two wire terminals 1.6" long.

C-2603 3D9300-19

Erie
CentralabTank, fixed, padding,
capacitor used on all
three bands

CAPACITOR: Fixed; ceramic; 2,200 microfarads $\pm 1\%$; overall dimensions 1-11/16" x 15/16" dia.; single No. 6-32 mounting bolt; one terminal grounded to metal case.

C-2604 3DA2.200-5

JAN Type
CM60F103JJAN-1625 cathode
by-pass

CAPACITOR: Fixed; mica; 10,000 microfarads $\pm 5\%$; 2500 volts DCW; 1-25/32" x 1-11/32" x 3/4"; two No. 6-32 tapped holes for terminals and mounting.

C-2605 3K6010362

Centralab
ErieTank, fixed, padding,
capacitor, 285-415
Kc and 200-285 Kc
bands

CAPACITOR: Fixed; ceramic; 2,065 microfarads $\pm 1\%$; overall dimensions 1-17/32" x 15/16" dia.; one terminal grounded; supplied with C-2607-A and C-2607-B as an assembly.

C-2606 3DA6.365

Centralab
ErieTank, fixed, padding,
capacitor, 200-285
Kc. band

CAPACITOR: Fixed; ceramic; with C-2607-B total capacity 4,300 microfarads $\pm 1\%$; 1-17/32" x 15/16" dia.; one terminal grounded; supplied with C-2606 and C-2607-B as an assembly.

C-2607-A 3DA6.365

Centralab
ErieTank, fixed, padding,
capacitor, 200-285
Kc. band

CAPACITOR: Fixed; ceramic; with C-2607-A total capacity 4,300 microfarads $\pm 1\%$; 1-17/32" x 15/16" dia.; one terminal grounded; supplied with C-2606 and C-2607-A as an assembly.

C-2607-B 3DA6.365

Centralab
ErieTank, variable, pad-
ding, capacitor 415-
600 Kc. band

CAPACITOR: Variable; ceramic; 55-240 microfarads; supplied with C-2608-B, C-2608-C and C-2608-D as an assembly.

C-2608-A 3D924V-4

Centralab
ErieTank, variable, pad-
ding, capacitor 285-
415 Kc. band

CAPACITOR: Same as C-2608-A.

C-2608-B 3D924V-4

Centralab
ErieTank, variable, pad-
ding, capacitor 200-
285 Kc. band

CAPACITOR: Same as C-2608-A.

C-2608-C 3D924V-4

Centralab
ErieTank, variable, pad-
ding, capacitor, 200-
285 Kc. band

CAPACITOR: Same as C-2608-A.

C-2608-D 3D924V-4

TABLE OF PARTS (Cont'd)

NOTE: Parts listed which are indicated by a # sign in column 2 are not available as spare parts and are listed for reference purposes only.

MODEL: RADIO TRANSMITTING SET AN ART-13A MAJOR ASSEMBLY: LOW FREQUENCY OSCILLATOR O-17 / ART-13A

Reference Symbol	Army Stock Number Navy Stock Number British Ref. Number	Name of Part and Description	Function	Mfr. and Desig. or Standard Type	Cont. or Govt. Dwg. or Spec. No.
E-2601	6L71002-2	WASHER: Open snap on type; dia. 5/16" x 0.20" thick; stainless steel; I.D. 0.124".	Used in assembling gear trains	New Arts Spec. 306	Stewart-Warner 565065
E-2602	2Z3766	DIAL KNOB: Complete with two H-2601 set screws; O-100 counterclockwise; black bakelite; max. dimensions 2-3/8" dia. x 0.887 thick.	Control G	Stewart-Warner 564987 General Electric ML-7893064-1	Stewart-Warner 564987
E-2603	2Z9403.48	RESISTOR BOARD: Bakelite; 2-1/4" x 15/16" x 3/32"; complete with solder lugs; less resistor and capacitor.	Mounting board for R-2601 and C-2603	H. B. Jones 3-1	Stewart-Warner 565075
E-2604	2Z5822-124	KNOB: Complete with two H-2602 set screws; zinc die casting; black finish; 3/8" x 1/2" dia.	CORRECTOR and LOCK knob	Stewart-Warner 564989 General Electric ML-7104261-1	Stewart-Warner 564989
E-2605	2Z5843.12	KNOB: Complete with H-2601 set screw; for switch S-2601; black bakelite; overall dimensions 1-1/8" x 3/4" x 11/16".	Control F	Stewart-Warner 564753 General Electric ML-7891557-1	Stewart-Warner 564753
E-2606	2Z3714-39	DIAL: Complete with shield and two H-2603 set screws; 0-20 range.	Revolution Counter for knob G	Stewart-Warner 564974 General Electric K-7893060	Stewart-Warner 564974
E-2607	#	PLATE CLIP AND LEAD: Consists of grid clip copper braid and solder lug.	Connects plate to output post	Stewart-Warner 564983 General Electric K-7101830	Stewart-Warner 564983
E-2608	3G100-4.1	STAND-OFF: Ceramic; 1/2" x 3/8" dia.; No. 6-32 threaded axial mounting holes at each end.	L-2601 terminal post	JAN Type NS4W0104	Stewart-Warner 564784
E-2609	3G1250-3.13	BUSHING: Ceramic; 5/8" dia. x 3/16" thick. Same as E-107.	Part of FEED-THROUGH for plate and cathode leads	Centralab X-414 General Ceramics D-2399	Stewart-Warner 564784
E-2610	#	SPACER: Bakelite; 1-3/4" x 5/8" x 5/16".	Mounting spacer for C-2605 capacitor	MiCarra Fab. Co. Aerovox Cornell-Dubilier	Stewart-Warner 565072
E-2611	2Z2642.63	CLAMP TUBE: 1-17/32" O.D. x 1-1/32" high; 2 mtg ears; 1-7/8" between mtg/c.	For X-2601	Collins Radio	Air Force 47B47219
H-2601	#	SCREW: No. 8-36 x 1/4; dial set screw; 6 flutes; multiple spline; cup point.	Dial knob mounting screw	Bristol Co. J. Larrabee Co.	Stewart-Warner 564018
H-2602	#	SCREW: No. 6-40 x 1/8"; knob set screw; multiple spline; 4 flutes; cup point.	Knob mounting screw	Bristol Co. Cambria Merc. Supplies Inc.	Stewart-Warner 564097

H-2603	#	SCREW: No. 4-48 x 1/8; knob set screw; multiple spline; 6 flutes; cup point.	Knob mounting screw	Bristol Co. Supplies Inc.	Stewart-Warner 564978
H-2604	#	BRACKET: Aluminum; U shape; complete with two No. 6-32 lock nuts.	C-2608-A-B-C-D capacitor mounting bracket	Stewart-Warner General Electric K-7101887	Stewart-Warner 565025
H-2605	#	"V" SPRING WASHER: Spring steel; O.D. 5/16"; I.D. 0.133".	Gear mounting	Shakeproof Inc. 3502-5V	Stewart-Warner 564994
H-2606	#	SHAFT: Brass; 1-3/4" x 0.203" dia.	Switch gear mounting shaft	Stewart-Warner General Electric K-7101876	Stewart-Warner 564967
H-2607	#	PLATE: 1-7/32" dia.; three 0.098 dia. mounting holes; steel.	Front, bearing mounting plate	Stewart-Warner General Electric K-7893027	Stewart-Warner 565034
H-2608	#	ROD, GUIDE: Steel; 4.669" x 0.187" dia. axial mounting hole at each end tapped No. 6-32.	Guide rod	Stewart-Warner General Electric K-7892979	Stewart-Warner 565013
L-2601	3C357-19	COIL, R-F CHOKE: 4 pie; universal winding; ceramic form; 5.4 millihenries; No. 36 nylon enamel wire; 1-3/8" x 7/8" dia.; single No. 6-32 threaded mounting hole.	JAN 1625 plate supply choke	E. I. Guthman Co. 30-5256 Oak Mfg. Co.	Stewart-Warner 565070
L-2602	3C323-114C	COIL: Oscillator; iron core tuned; 50 turns No. 26 D.E. wire; ceramic coil form 2.772 x 1.5" max. dia.; operated by Control G; three tapped No. 6-32 mounting holes.	Low frequency oscillator coil	Aladdin Radio 49-158	Stewart-Warner 565035
L-2603	3C326-100.1	COIL, R-F CHOKE: 4 pie; universal winding; ceramic form; 2.5 millihenries; No. 36 S.S.E. wire; 1-15/16" x 1/2" dia.; single No. 6-32 threaded mounting hole; cotter pin terminals. Same as L-102.	JAN 1625 cathode R-F choke	E. I. Guthman 30-5221 National Co. R-100S	Stewart-Warner 564609
O-2601	2C6900-47A/7	GEAR AND BUSHING: Aluminum; 1.082" dia. x 25/64" I.D. 0.187"; two No. 6-40 tapped set screw mounting holes, 90° apart.	S-2601 switch gears	Stewart-Warner 564955 General Electric ML-7101884-1	Stewart-Warner 564955
O-2602	2C6900-47A/5	DISC, LOCKING ASSEMBLY: O.D. 1-3/4"; I.D. 0.189"; brass; 0.625" thick; two No. 6-40 tapped set screw mounting holes, 90° apart.	Control G locking disc	Stewart-Warner 564961 General Electric ML-7893319	Stewart-Warner 564961
O-2603	2C6900-47A/2	GEAR, ASSEMBLY: Aluminum gear; brass hub; O.D. 1.917"; 0.921" thick; mounted by E-2601 split washer.	REVOLUTION COUNTER coupling gear	Stewart-Warner 564942 General Electric ML-7101883	Stewart-Warner 564942
O-2604	2C2600-47A/6	GEAR, PINION: Brass; O.D. 0.667"; I.D. 0.156" 13/32" thick.	REVOLUTION COUNTER coupling gear	Stewart-Warner 564966 General Electric 7472561	Stewart-Warner 564966
O-2605	2C6900-47A/10	LOCKING ARM ASSEMBLY: Consists of stationary bracket, pinion and bakelite button.	Operated by LOCK knob	Stewart-Warner 564948 General Electric ML-7101868-1	Stewart-Warner 564948
O-2605A	2Z380-70	ARM ASSEMBLY: Consists of moving bracket and bakelite button.	Operated by LOCK knob		Air Force 47B47255

TABLE OF PARTS (Cont'd)

NOTE: Parts listed which are indicated by a # sign in column 2 are not available as spare parts and are listed for reference purposes only.

MODEL: RADIO TRANSMITTING SET AN/ART-13A MAJOR ASSEMBLY: LOW FREQUENCY OSCILLATOR O-17/ART-13A

Reference Symbol	Army Stock Number Navy Stock Number British Ref. Number	Name of Part and Description	Function	Mfr. and Desig. or Standard Type	Cont. or Govt. Dwg. or Spec. No.
O-2606	2C6900-47A/3	GEAR AND STOP ASSEMBLY: O.D. 1.917"; I.D. 0.125"; 0.921" thick; aluminum gear; brass hub; steel stop.	REVOLUTION COUNTER gear and stop	Stewart-Warner 564945 General Electric M-7101875-1	Stewart-Warner 564945
O-2607	3H320-106	BEARING ASSEMBLY: Complete with bearing, spring, and retainer; O.D. 1-7/32" x 0.687" thick. AF Stock No. 3300-336089386.	Back bearing assembly	Stewart-Warner 564975 General Electric K-7894125 G1	Stewart-Warner 564975
P-2601	2Z7227-2	CONNECTOR: Male; 6 prong; molded case 1" x 5/8" x 1/2"; two mounting brackets each with a 0.146" dia. hole, 1" between mtg/c.	L.F.O. connector to transmitter	H. B. Jones P-306-AB	Stewart-Warner 564984
R-2601	3RC31BF153K	RESISTOR: Fixed; carbon; 15,000 ohms $\pm 10\%$; 1 watt; insulated; max. dimensions 1.280" x 0.310" dia, 1-1/2" axial wire leads.	V-2601 grid leak resistor	JAN Type RC31BF153K	
S-2601	3Z9825-62.175	SWITCH: Rotary; 3 positions; single deck; single circuit; ceramic insulation; overall dimensions 1-7/8" x 1-5/8" x 1-19/32"; single hole mounting on 3/8-32" threaded hub.	Low frequency band selector switch	Centralab 7356 Oak 27817-H1C	Stewart-Warner 565063
V-2601	2J1625	TUBE: Type JAN 1625, transmitter beam power amplifier.	Low frequency oscillator tube	JAN Type 1625	
X-2601	2Z8677.20	SOCKET: Tube; 7 terminal; ceramic insulation 2-5/16" x 1-13/16" x 9/16"; two mounting slots 11/64" x 17/64", 1-25/32" between mtg/c.	Socket for V-2601 tube	National Fab. 42C1D Ucinite 115166 E. F. Johnson 227 N-BC	Stewart-Warner 564528

MAJOR ASSEMBLY: DYNAMOTOR DY-17/ART-13A

C-2701	3DB2E25-1	CAPACITOR: Fixed; paper; 2.25 microfarads $\pm 20\%$ — 10%; 100 volts DCW; metal case 1-1/2" x 1-13/16" x 7/8" thick; two solder lug terminals spaced 1" apart; two mounting feet each with a 3/16" dia. hole, 2-1/8" between mtg/c.	Dynamotor input filter	Sprague P2908 Solar Mfg. Co. XDDHRTW1-225-1020 Cornell-Dubilier GC 146	Stewart-Warner 564927
C-2702	3DB2E5-3	CAPACITOR: Fixed; paper; 2.5 microfarads $\pm 20\%$; 100 volts DCW; metal case 2" x 2" x 1"; two solder lug terminals; two mounting feet with 3/16" dia. holes, 2-3/8" between mtg/c.	Dynamotor input filter	Sprague P2907 Solar Mfg. Co. XDHRW1-25-20 Cornell-Dubilier HC 4106	Stewart-Warner 564926
C-2703	3DB4-166	CAPACITOR: Fixed; paper; 4 microfarads $\pm 20\%$; 600 volts DCW; oil impregnation; metal case 3-1/4" x 2-1/2" x 1-3/16"; two solder lug terminals spaced 1" apart.	Low voltage B supply filter	Condenser Prod. AOC-46 Solar Mfg. Co. XLCW6-4-20	Stewart-Warner 564903

C-2704-A	3DA100-116.4	CAPACITOR: Fixed; paper; triple section consisting of three identical capacitors C-2704-A, C-2704-B and C-2704-C; each 100,000 microfarads $\pm 20\%$; oil filled; 600 volts DCW; all three enclosed in a metal case 1-3/16" x 1" x 3/4"; solder lug terminals; two mounting feet each with a 3/16" dia. hole 2-1/8" between mtg. c.	Voltmeter multiplier resistor by-pass	Sprague P 2947 Solar Mfg. Co. 3XDMRTW6-1-20 Micamold 306-231	Stewart-Warner 564402
C-2704-B		CAPACITOR: Same as C-2704-A.	Voltmeter multiplier resistor by-pass		
C-2704-C		CAPACITOR: Same as C-2704-A.	By-pass from fuse to ground		
C-2705	3DB2-37	CAPACITOR: Fixed; paper; 2 microfarads $\pm 20\%$; 600 volts DCW; oil filled; metal case 2-3/4" x 1-13/16" x 1-1/16" thick; two solder lug terminals spaced 1" apart. Same as C-126.	Low voltage B supply to dynamotor, filter	Cornell-Dubilier KC-3020-13G Micamold 324 Sprague P 2948 Solar Mfg. Co. KLMRAW6-2-20 General-Electric 25F764	Stewart-Warner 564401
C-2706	3DB2.15020-2	CAPACITOR: Fixed; paper; 2 microfarads $\pm 20\%$; 1500 volts DCW; oil filled; metal case 4" x 2-1/2" x 1-1/4" thick; two No. 10-32 terminal bolts spaced 1-1/8" apart.	High voltage B supply filter	Condenser Prod. AOC-4-6 Solar Mfg. Co. KLMW15-2-20	Stewart-Warner 564904
C-2707	3DA120-1	CAPACITOR ASSEMBLY: Supplied with two mounting brackets; fixed; acetate; 120,000 microfarads; 600 volts DCW; oil filled; 2-1/8" x 3/4" dia.; No. 8-32 mounting stud at each end; used only on Russell Dynamotor.	M.V. brush filter	Russell Electric 14909	Stewart-Warner 565681
C-2708	3DA100-376	CAPACITOR: Fixed; acetate; 100,000 microfarads; 1250 volts DCW; oil filled; 2-1/8" x 3/4" dia.; No. 8-32 mounting stud at each end; used only on Russell Dynamotor.	H. V. brush filter	Russell Electric 14908	Stewart-Warner 565682
C-2709	3K4010324	CAPACITOR: Fixed; mica; 10,000 microfarads; 500 volts DCW; molded; 1" x 5/8" x 5/16"; lug terminals for No. 10 screws; used only on Russell Dynamotor.	L. V. brush filter	JAN Type CM40B103M	
C-2710	3DA120-2	CAPACITOR ASSEMBLY: Supplied with one mounting bracket; fixed; acetate; 120,000 microfarads; No. 8-32 mounting stud at each end. Used only on Russell dynamotor.	H.V. negative brush, to ground, filter capacitor	Russell Electric 14910	Stewart-Warner 565684
C-2712	3DA400-32	CAPACITOR: 400,000 microfarads; 200 volts DCW. Used only on General Electric dynamotor.	L.V. brush filter	General-Electric K-8701807AB-G1	
C-2713	3DA400-31	CAPACITOR: 400,000 microfarads; 200 volts DCW. Used only on General-Electric dynamotor.	L.V. brush filter	General-Electric K-8701807AB-G2	
C-2714	3DA64	CAPACITOR: 64,000 microfarads; 1,600 volts DCW. Used only on General-Electric dynamotor.	H.V. positive brush, to ground, filter capacitor	General-Electric K-8701807AB-G3	
C-2715	3DA80-7	CAPACITOR: 80,000 microfarads; 1,000 volts DCW. Used only on General-Electric dynamotor.	H.V. negative brush, to ground, filter capacitor	General-Electric K-8701807AB-G4	
C-2716		CAPACITOR: 120,000 microfarads; 1,000 volts DCW complete with mounting bracket. Used only on General-Electric dynamotor.	M.V. brush filter capacitor	General-Electric K-8701807AA-G1	
C-2717	3DA400-33	CAPACITOR: 400,000 microfarads, 200 volts DCW complete with mounting bracket. Used only on General-Electric dynamotor.	Positive input, to ground, filter capacitor	General-Electric K-8701807AC-G1	

TABLE OF PARTS (Cont'd)

NOTE: Parts listed which are indicated by a # sign in column 2 are not available as spare parts and are listed for reference purposes only.

MODEL: RADIO TRANSMITTING SET AN ART-13A MAJOR ASSEMBLY: DYNAMOTOR DY-17/ART-13A

Reference Symbol	Army Stock Number Navy Stock Number British Ref. Number	Name of Part and Description	Function	Mfr. and Desig. or Standard Type	Cont. or Govt. Dwg. or Spec. No.
C-2718	3DA150-1 ^s	CAPACITOR: Fixed; acetate; 150,000 micromicrofarads -20%, +0%; 100 vdcw.	L.V. brush filter	Russell Electric 15397	
D-2701		DYNAMOTOR: Input rating 27 volts DC, 31-1/2 amperes; low voltage output rating 400 volts DC, 750 milliamperes; high voltage output rating 750 volts DC, 350 milliamperes; dimensions 10-7/8" x 5" dia.; ventilating screens at each end; input leads, A+ white, A- black; low voltage output +red-black, -black; high voltage output, +red, -green.	Power supply	Russell Elec. 14875 General-Electric M-7471876	Stewart-Warner 564801
E-2701	3Z3285-3	FUSE HOLDER: Complete with mounting nuts and bakelite cap; overall dimensions 2-13/32" x 13/16"; solder lug terminals.	400 volt fuse holder	Bussman Mfg. Co. HCM-1	Stewart-Warner 564682
E-2702	2Z9403.6	TERMINAL BOARD: Bakelite; 2-1/16" x 7/8" x 1/2"; four 0.156" dia. mounting holes 1.750" x 0.437" between mtg/c; complete with terminal links and terminal screws.	Terminal board	H. B. Jones 3-141	Stewart-Warner 564769
E-2704	3H1535-17/B5	BRUSH: Carbon 3/4" x 0.273" x 0.085"; overall length 1-17/32"; used only on Russell dynamotor.	H.V. dynamotor brush	Russell Elec. 15313	Stewart-Warner 565552
E-2705	3H1535-17/B5	BRUSH: Same as E-2704.	H.V. dynamotor brush	Russell Elec. 15313	
E-2706	3H1535-17/B6	BRUSH: 3/4" x 0.273" x 0.109"; overall length 1-25/32"; used only on Russell dynamotor.	M.V. dynamotor brush	Russell Elec. 15312	Stewart-Warner 565567
E-2707	3H1535-17/B6	BRUSH: Same as E-2706.	M.V. dynamotor brush	Russell Elec. 15312	
E-2708	3H1535-17/B7	BRUSH: Carbon 3/4" x 0.619" x 0.260"; overall length 1-11/16"; used only on Russell dynamotor.	L.V. dynamotor brush	Russell Elec. 15311	Stewart-Warner 565551
E-2709	3H1535-17/B7	BRUSH: Same as E-2708.	L.V. dynamotor brush	Russell Elec. 15311	
E-2710	3H1535-17/B7	BRUSH: Otherwise same as E-2708.	L.V. dynamotor brush	Russell Elec. 15311	
E-2711	3H1535-17/B7	BRUSH: Otherwise same as E-2708.	L.V. dynamotor brush	Russell Elec. 15311	
E-2712	3H2575-218E/C1	CAP, BRUSH HOLDER: 9/32" thk. x 11/16" dia. bakelite cover; used only on Russell dynamotor.	H.V. brush holder	Russell Elec. 12813	Stewart-Warner 565686
E-2713	3H2575-218E/C1	CAP, BRUSH HOLDER: Same as E-2712.	H.V. brush holder		
E-2714	3H2575-218E/C1	CAP, BRUSH HOLDER: Same as E-2712.	M.V. brush holder		
E-2715	3H2575-218E/C1	CAP, BRUSH HOLDER: Same as E-2712.	M.V. brush holder		
E-2716	3H1535-17/C1	CAP, BRUSH HOLDER: 1/2" thk. x 1-3/16" dia. bakelite cover; used only on Russell dynamotor.	L.V. brush holder	Russell Elec. 15308	Stewart-Warner 565687
E-2717	3H1535-17/C1	CAP, BRUSH HOLDER: Same as E-2716.	L.V. brush holder		
E-2718	3H1535-17/C1	CAP, BRUSH HOLDER: Same as E-2716.	L.V. brush holder		

E-2719	3H1535-17/C1	CAP, BRUSH HOLDER: Same as E-2716.	L.V. brush holder	General-Electric	Stewart-Warner
E-2720	3H525GE-6	BRUSH: Used only on GE dynamotor.	L.V. brush	K-5868922AC2	564767
E-2721	3H525GE-6	BRUSH: Same as E-2720.	L.V. brush	General-Electric	Stewart-Warner
E-2722	3H525GE-6	BRUSH: Same as E-2720.	L.V. brush	K-5868922AC2	564906
E-2723	3H525GE-6	BRUSH: Same as E-2720.	L.V. brush	General-Electric	Stewart-Warner
E-2724	3H525GE-5	BRUSH: Used only on GE dynamotor.	M.V. brush	K-5868926ABB	564774
E-2725	3H525GE-5	BRUSH: Same as E-2724.	M.V. brush	General-Electric	Stewart-Warner
E-2726	3H525GE-5	BRUSH: Same as E-2724.	H.V. brush	K-5868926ABB	564775
E-2727	3H525GE-5	BRUSH: Same as E-2724.	H.V. brush	General-Electric	Stewart-Warner
E-2728	3H683-13	CAP, BRUSH HOLDER: Used only on GE dynamotor.	L.V. brush holder, cap	K-8701214AA1	565008
E-2729	3H683-13	CAP, BRUSH HOLDER: Same as E-2728.	L.V. brush holder, cap	General-Electric	Stewart-Warner
E-2730	3H683-13	CAP, BRUSH HOLDER: Same as E-2728.	L.V. brush holder, cap	K-8701214AA1	565007
E-2731	3H683-13	CAP, BRUSH HOLDER: Same as E-2728.	L.V. brush holder, cap	General-Electric	Stewart-Warner
E-2732	3H683-14	CAP, BRUSH HOLDER: Used only on GE dynamotor.	M.V. brush holder, cap	K-8701214AA1	565007
E-2733	3H683-14	CAP, BRUSH HOLDER: Same as E-2732.	M.V. brush holder, cap	General-Electric	Stewart-Warner
E-2734	3H683-14	CAP, BRUSH HOLDER: Same as E-2732.	H.V. brush holder, cap	K-8701214AA1	565007
E-2735	3H683-14	CAP, BRUSH HOLDER: Same as E-2732.	H.V. brush holder, cap	General-Electric	Stewart-Warner
F-2701	3Z2601.32	FUSE: Aircraft type; bakelite; enclosed cartridge fuse; anti-vibration; 1 ampere; 250 volt; 1-1/4" x 9/32" dia.	Low voltage output fuse	Littlefuse Inc.	Stewart-Warner
F-2702	3Z2601.32	FUSE: Same as F-2701.	Power fuse	1091-1 ampere 4AB	564767
H-2701	#	LATCH SCREW & KNOB ASSEMBLY: Steel screw, brass knob; approx. 1-3/4" overall length.	Power unit mounting lock	Stewart-Warner	Stewart-Warner
H-2702	#	LATCH: Aluminum bronze; max. dia. .536" x 13/32" thk., 1/4-20 tapped screw hole.	Latch for H-2701	564906	564922
H-2703	#	C WASHER: Stainless steel.	Used on H-2701	General-Electric	Stewart-Warner
H-2704	#	CLAMP: Capacitor mounting; steel.	C-2706 capacitor mounting bracket	K-7101892	564922
H-2705	#	CLAMP: Capacitor mounting; steel.	C-2703 and C-2705 capacitor mounting bracket	Master Prod. Co.	Stewart-Warner
J-2701	2Z8680-7	CONNECTOR: Female; 10 contact; wall mounting; two 15 ampere contacts; eight 10 ampere contacts; 2-1/8" x 2-1/8" x 1-5/64" thk.; four 0.169" dia. mounting holes.	B supply to transmitter connector	Oak Mfg. Co.	Stewart-Warner
J-2702	2Z8673.47	CONNECTOR: Female; three contact; wall mounting; two 60 ampere contacts; one 15 ampere contact; 1-1/4" x 1-1/4" x 1-1/32" thk.; screw type connection; four 0.120" dia. mounting holes.	Primary power connector	Stewart-Warner	Stewart-Warner

TABLE OF PARTS (Cont'd)

NOTE: Parts listed which are indicated by a # sign in column 2 are not available as spare parts and are listed for reference purposes only.

MODEL: RADIO TRANSMITTING SET AN/ART-13A

MAJOR ASSEMBLY: DYNAMOTOR DY-17/ART-13A

Reference Symbol	Army Stock Number Navy Stock Number British Ref. Number	Name of Part and Description	Function	Mfr. and Desig. or Standard Type	Cont. or Govt. Dwg. or Spec. No.
K-2701	2Z7589-86	RELAY: Two pole; double throw; contacts rated 12 amperes 28 volts D.C. non-inductive load; nominal coil voltage 28 volts D.C.; coil resistance 115 ohms min.; outside dimensions 3-1/32" x 2-1/16" x 1-3/4".	Power change relay	Leach Relay Co. 1067-2W Guardian Elec. G-36470	Stewart-Warner 564536
K-2702	2Z7586-83	RELAY: One pole normally open; double break; contacts rated 25 amperes 28 volts D.C. non-inductive load; nominal coil voltage 28 volts D.C.; coil resistance 135 ohms min.; outside dimensions 3-1/16" x 1-45/64" x 1-7/8"; four solder lug terminals; two mounting feet each with two holes threaded for No. 8-32 machine screws 2.375" x 0.695" between mtg/c.	Primary power contactor	Allied Ctrl. HRX1 Leach Relay Co. 1091 Guardian Elec. 36471 Allied Control BOX 45	Stewart-Warner 564535
K-2703	2Z7586-82	RELAY: Solenoid type; single pole normally open; double break; contacts rated 100 amperes 28 volts D.C. non-inductive load; nominal coil voltage 28 volts D.C.; coil resistance 75 ohms min.; outside dimensions 3-3/16" x 2-7/32" x 2-1/4"; No. 8-32 brass screw coil terminals.	Dynamotor input relay	R.B.M. Mfg. Co. RBM No. 17280 Guardian Elec. G-36469	Stewart-Warner 564534
K-2704	3Z9586-1	BAROMETRIC SWITCH: Single circuit; normally open; snap action (toggle) switch; operated by bellows responding to changes in atmospheric pressure; range 20,000 to 25,000 feet; overall dimensions 3-13/16" x 3-3/8" x 2-1/8".	Altitude voltage control	General-Electric K-7890854-1 Air Communications 23M	Stewart-Warner 564916
K-2705	3H900-10-12	RELAY: Overload; nominal rating 10 amperes; push-button will expose a fluorescent phosphorescent band and a red band when relay has tripped; bakelite case 2-1/16" x 1-33/64" x 3/4"; two mounting holes tapped for No. 6-32 screw, 1.812" between mtg/c; two terminal lugs each with a No. 8-32 brass R.H. screw.	Transmitter overload relay	Square D Co. 9310 type 10A	Stewart-Warner 565023
K-2706	3H900-35-13	RELAY: Overload; nominal rating 35 amperes; push-button reset; button will expose a fluorescent phosphorescent band and a red band when relay has tripped; bakelite case 2-1/16" x 1-33/64" x 3/4"; two mounting holes tapped for No. 6-32 screw, 1.812" between mtg/c; two terminal lugs each with a No. 8-32 brass R.H. screw.	Dynamotor overload relay	Square D Co. 9310 type 35A	Stewart-Warner 565024
L-2701	3C323-12G	COIL: Choke; radio frequency; 15-3/4 turns of No. 9 A.W.C. copper wire with nylon or equivalent insulation; inductance 5.5 microhenries 20% at 1000 cycles; helical type coil; terminal lugs to fit No. 10 screw; iron core; core dimensions approx. 2-1/2" x 7/8" dia. single No. 8-32 mounting bolt.	Dynamotor input filter choke	J. E. Fast A8084	Stewart-Warner 564997
L-2702	3C1075-2	COIL: Choke; radio frequency; 3 pie universal winding on ceramic form; No. 29 S.S.E. or No. 29 S.C.E. wire; inductance in air 500 microhenries 10% at 1000 cycles; overall dimensions 1-15/16" x 5/8" dia.; single hole for mounting tapped for No. 6-32 screw.	Low voltage B supply filter choke	E. I. Guthman Co. 30-5281 Standard Wind. A-545-2	Stewart-Warner 564917

TABLE OF PARTS (Cont'd)

NOTE: Parts listed which are indicated by a # sign in column 2 are not available as spare parts and are listed for reference purposes only.

MODEL: RADIO TRANSMITTING SET AN/ART-13A MAJOR ASSEMBLY: DYNAMOTOR DY-17/ART-13A

Reference Symbol	Army Stock Number	Navy Stock Number	British Ref. Number	Name of Part and Description	Function	Mfr. and Desig. or Standard Type	Cont. or Govt. Dwg. or Spec. No.
K-2701			2Z7589-86	RELAY: Two pole; double throw; contacts rated 12 amperes 28 volts D.C. non-inductive load; nominal coil voltage 28 volts D.C.; coil resistance 115 ohms min.; outside dimensions 3-1/32" x 2-1/16" x 1-3/4".	Power change relay	Leach Relay Co. 1067-2W Guardian Elec. G-36470 Allied Ctrl. HRX1	Stewart-Warner 564536
K-2702			2Z7586-83	RELAY: One pole normally open; double break; contacts rated 25 amperes 28 volts D.C. non-inductive load; nominal coil voltage 28 volts D.C.; coil resistance 135 ohms min.; outside dimensions 3-1/16" x 1-45/64" x 1-7/8"; four solder lug terminals; two mounting feet each with two holes threaded for No. 8-32 machine screws 2.375" x 0.695" between mtg/c.	Primary power contactor	Leach Relay Co. 1091 Guardian Elec. 36471 Allied Control BOX 45	Stewart-Warner 564535
K-2703			2Z7586-82	RELAY: Solenoid type; single pole normally open; double break; contacts rated 100 amperes 28 volts D.C. non-inductive load; nominal coil voltage 28 volts D.C.; coil resistance 75 ohms min.; outside dimensions 3-3/16" x 2-7/32" x 2-1/4"; No. 8-32 brass screw coil terminals.	Dynamotor input relay	R.B.M. Mfg. Co. RBM No. 17280 Guardian Elec. G-36469	Stewart-Warner 564534
K-2704			3Z9586-1	BAROMETRIC SWITCH: Single circuit; normally open; snap action (toggle) switch; operated by bellows responding to changes in atmospheric pressure; range 20,000 to 25,000 feet; overall dimensions 3-13/16" x 3-3/8" x 2-1/8".	Altitude voltage control	General Electric K-7890854-1 Air Communications 23M	Stewart-Warner 564916
K-2705			3H900-10-12	RELAY: Overload; nominal rating 10 amperes; push-button will expose a fluorescent phosphorescent band and a red band when relay has tripped, bakelite case 2-1/16" x 1-33/64" x 3/4"; two mounting holes tapped for No. 6-32 screw, 1.812" between mtg/c; two terminal lugs each with a No. 8-32 brass R.H. screw.	Transmitter overload relay	Square D Co. 9310 type 10A	Stewart-Warner 565023
K-2706			3H900-35-15	RELAY: Overload; nominal rating 35 amperes; push-button reset; button will expose a fluorescent phosphorescent band and a red band when relay has tripped; bakelite case 2-1/16" x 1-33/64" x 3/4"; two mounting holes tapped for No. 6-32 screw, 1.812" between mtg/c; two terminal lugs each with a No. 8-32 brass R.H. screw.	Dynamotor overload relay	Square D Co. 9310 type 35A	Stewart-Warner 565024
L-2701			3C323-12G	COIL: Choke; radio frequency; 15-3/4 turns of No. 9 A.W.C. copper wire with nylon or equivalent insulation; inductance 5.5 microhenries 20% at 1000 cycles; helical type coil; terminal lugs to fit No. 10 screw; iron core; core dimensions approx. 2-1/2" x 7/8" dia. single No. 8-32 mounting bolt.	Dynamotor input filter choke	J. E. Fast A8084	Stewart-Warner 564997
L-2702			3C1075-2	COIL: Choke; radio frequency; 3 pie universal winding on ceramic form; No. 29 S.S.E. or No. 29 S.C.E. wire; inductance in air 500 microhenries 10% at 1000 cycles; overall dimensions 1-15/16" x 5/8" dia.; single hole for mounting tapped for No. 6-32 screw.	Low voltage B supply filter choke	E. I. Guthman Co. 30-5281 Standard Wind. A-545-2	Stewart-Warner 564917

L-2703	3C326-300.1	COIL: Choke; radio frequency; 3 pie universal winding; No. 32 S.S.E. wire; ceramic form; inductance in air 1.0 millihenry \pm 10% at 1000 cycles; overall dimensions 1 $\frac{1}{8}$ " x $\frac{1}{2}$ " dia.; single hole for mounting tapped for No. 6-32 screw. Same as L-116.	Low voltage B return to dynamotor filter	E. I. Guthman Co. 30-5220-2 National Co. Inc. R-300-S Standard Winding A-545-1	Stewart-Warner 564633
L-2704	3C326-300.1	COIL: Same as L-2703.	High voltage B supply filter		
R-2701-A	3Z6002-34	RESISTOR: 6.7 ohms \pm 5%; this is one section of a 20.1 ohm tapped resistor; 5 watts in open air (10 watt size); wire wound; vitreous enameled; overall dimensions 1 $\frac{3}{4}$ " x $\frac{1}{8}$ " x $\frac{3}{8}$ "; three solder lug terminals each with a $\frac{1}{8}$ " dia. hole; $\frac{3}{8}$ " dia. axial mounting hole.	Voltmeter multiplier	Federal Elec. Co. Type No. 231 Ohmite No. 15626	Stewart-Warner 564921
R-2701-B	3Z6002-34	RESISTOR: 13.4 ohms \pm 5%; see R-2701-A.	Voltmeter multiplier	Federal Elec. Co. Type No. 231 Ohmite 15626	Stewart-Warner 564921
R-2702	3Z6033-21	RESISTOR: 330 ohms \pm 20%; 1 watt; carbon or wire wound; insulated; 1.280" x 0.310" dia. max.; 1 $\frac{1}{2}$ " axial wire leads; max. inductance microhenries. Same as R-2217.	Low voltage B return to dynamotor filter	I.R.C. BT-1	Stewart-Warner 564766

MAJOR ASSEMBLY: DYNAMOTOR DY-17A/ART-13A

C2701		CAPACITOR ASSEMBLY: Fixed; paper; 15,000 microfarads \pm 10%; 200 volts DCW; molded plastic case $\frac{1}{8}$ " dia. x 1" long; supplied with terminal lugs for No. 10 and 8 studs; overall length 2 $\frac{3}{8}$ ".	L.V. brush filter		Eicor 23-1161
D2701		DYNAMOTOR: Input rating 28 volts DC, 33 amperes; medium voltage output rating 410 volts DC, 750 milliamperes; medium and high voltage generators in series, output rating 1190 volts DC, 350 milliamperes; overall dimensions 11 $\frac{1}{4}$ " x 5" dia.; ventilating screens at each end; input leads A + white, A - black; medium voltage output, + black-red, - black; high voltage output, + red, - green.	Power Supply		Eicor 1-5023-1
E2701		BRUSH AND SPRING ASSEMBLY: Carbon brush $\frac{5}{8}$ " x 0.218" x 0.095"; overall length 1 $\frac{1}{8}$ ".	M.V. + dynamotor brush		Eicor 2-1609
E2702		BRUSH AND SPRING ASSEMBLY: Carbon brush $\frac{5}{8}$ " x 0.218" x 0.095"; overall length 1 $\frac{1}{8}$ ".	M.V. - dynamotor brush		Eicor 2-1646
E2703		BRUSH AND SPRING ASSEMBLY: Same as E2701.	H.V. + dynamotor brush		
E2704		BRUSH AND SPRING ASSEMBLY: Same as E2702.	H.V. - dynamotor brush		
E2705		BRUSH AND SPRING ASSEMBLY: Carbon brush $\frac{5}{8}$ " x 0.262" x 0.620"; overall length 1 $\frac{3}{4}$ ".	L.V. + dynamotor brush		Eicor 2-1611
E2706		BRUSH AND SPRING ASSEMBLY: Carbon brush $\frac{5}{8}$ " x 0.262" x 0.620"; overall length 1 $\frac{3}{4}$ ".	L.V. - dynamotor brush		Eicor 2-1645
E2707		BRUSH AND SPRING ASSEMBLY: Same as E2705.	L.V. + dynamotor brush		
E2708		BRUSH AND SPRING ASSEMBLY: Same as E2706.	L.V. - dynamotor brush		

TABLE OF PARTS (Cont'd.)

NOTE: Parts listed which are indicated by a # sign in column 2 are not available as spare parts and are listed for reference purposes only.

MODEL: RADIO TRANSMITTING SET AN/ART-13A MAJOR ASSEMBLY: DYNAMOTOR DY-17A/ART-13A

Reference Symbol	Army Stock Number Navy Stock Number British Ref. Number	Name of Part and Description	Function	Mfr. and Desig. or Standard Type	Cont. or Govt. Dwg. or Spec. No.
E2709		CAP, BRUSH HOLDER: 0.233" thk. x 0.500" dia.; brass, nickel plated.	M.V. brush holder		Eicor 4-1013
E2710		CAP, BRUSH HOLDER: Same as E2709.	M.V. brush holder		
E2711		CAP, BRUSH HOLDER: Same as E2709.	H.V. brush holder		
E2712		CAP, BRUSH HOLDER: Same as E2709.	H.V. brush holder		
E2713		CAP, BRUSH HOLDER: 31/64" thk. x 1 1/8" dia.; bakelite cover.	L.V. brush holder		Eicor BHC-201
E2714		CAP, BRUSH HOLDER: Same as E2713.	L.V. brush holder		
E2715		CAP, BRUSH HOLDER: Same as E2713.	L.V. brush holder		
E2716		CAP, BRUSH HOLDER: Same as E2713.	L.V. brush holder		
F2701		FUSE: Steatite enclosed, shatterproof; medium lag; spring and link construction 1 ampere, 250 volt; 1/4" x 0.294" dia.	L.V. output fuse	Littlefuse, Inc. 414001	Eicor FUS-150
F2702		FUSE: Same as F2701.	Spare fuse		
FL2701		FILTER: Low pass; 200 volts DC test; metal case 2" x 2" x 1 1/2"; two screw terminals; two mounting feet with three holes for No. 8 screws.	Dynamotor input filter		Eicor FIL-195
FL2702		FILTER: Low pass; two section; 1000 volts DC test; metal case 2-19/64" x 2 1/8" x 1 7/8"; four screw terminals; two mounting feet with four holes for No. 8 screws.	Medium voltage supply filter		Eicor FIL-196
FL2703		FILTER: Low pass; 2500 volts DC test; metal case 2 1/8" x 2 1/2" x 1 7/8"; two screw terminals; two mounting feet with three holes for No. 8 screws.	High voltage supply filter		Eicor FIL-197
H2701		LATCH KNOB SUBASSEMBLY: Stainless steel screw; brass knob; pressed and swedged together; approx. 1 7/8" overall length.	Power unit mounting lock		Eicor 39-1060
H2702		CLIP, LATCH: Bronze; 1.074" dia. x 3/32" thk.; 1/4-20 tapped screw hole.	Clip for H2701		Eicor CLI-302A
H2703		"C" WASHER: Steel, Cd pl; 0.329" OD x 0.187" ID x 0.33" thk.	Used on H2701		Eicor WAS-808
H2704		CLIP, CABLE: Nylon, black; 3/8" dia. opening for cable; 13/64" mounting hole.	For control box cable		Eicor CLI-303
J2701		CONNECTOR: Female; 10 contact; wall mounting; two 15 ampere contacts; eight 10 ampere contacts; 2 1/8" x 2 1/8" x 1-5/64" thk.; four 0.169" dia. mounting holes.	B supply to transmitter connector	Cannon Elec. RFK-10-31SL	Eicor SOC-200

J2702	CONNECTOR: Female; three contact; wall mounting; two 60 ampere contacts; one 15 ampere contact; 1 1/4" x 1 1/4" x 1 1/2" thick; screw type connection; four 0.120" dia. mounting holes.	Primary power connector	Cannon Elec. GK-C3-32S	Eicor SOC-201
K2701	RELAY: Single pole; double throw; to meet requirements of AN3324-1, except that contacts must withstand 1500 volts DC to ground.	Power change relay		Eicor SWI-303
K2702	RELAY: One pole normally open; double break; to meet requirements of AN3350-2.	Primary power contactor		Eicor SWI-305
K2703	RELAY: Same as K2702.	Dynamotor input relay		
R2701	RESISTOR: Fixed; two section, tapped; total resistance 20.1 ohms; "A" section 6.7 ohms \pm 5%; "B" section 13.4 ohms \pm 5%; 10 watt size; vitreous enamel coated; overall length 1 3/4"; three solder lug terminals with 3/8" dia. hole; 1/8" dia. axial mounting hole.	Voltmeter multiplier	Lectrohm, Inc. U-287	Eicor RES-406
S2701	CIRCUIT BREAKER: Push pull type; 10 ampere capacity; to meet requirements of AN3161P10.	Transmitter overload breaker	Square D Co. Class 9311 Type 10A	Eicor SWI-301
S2702	CIRCUIT BREAKER: Push pull type; 35 ampere capacity; to meet requirements of AN3161P35.	Dynamotor overload breaker	Square D Co. Class 9311 Type 35A	Eicor SWI-304
S2703	SWITCH, BAROMETRIC: Single circuit; normally open; snap action (toggle) switch; operated by bellows responding to changes in atmospheric pressure; contacts close at 23,000 \pm 2000 feet.	Altitude voltage control		Eicor SWI-302
XF2701	FUSE HOLDER: Complete with mounting nuts and cap; panel mounting through 41/64" hole; solder lug terminals.	For fuse F2701	Bussman Mfg. Co. Type HCM-H	Eicor FPO-125
XF2702	FUSE HOLDER: Same as XF2701.	For fuse F2702		

MAJOR ASSEMBLY: ANTENNA LOADING UNIT C4-32/ART-13A

C-2501	3K7036123	CAPACITOR: Fixed; mica; 360 micromicrofarads \pm 2%; 5000 volts DCW; 3-9/64" x 2-1/4" x 1-17/64"; molded; two 0.180" dia. mounting holes 2.625" between mtg/c; two No. 10-32 terminal studs.	M-2501 meter coupling capacitor	JAN Type CM70B361G
C-2502	3K7056123	CAPACITOR: Fixed; mica; 560 micromicrofarads \pm 2%; 5000 volts DCW; 3-9/64" x 2-1/4" x 1-17/64"; molded; two 0.180" dia. mounting holes 2.625" between mtg/c; two No. 10-32 terminal studs.	M-2501 meter coupling capacitor	JAN Type CM70B561G
E-2501	2Z9406.132	BOARD, TERMINAL: Less resistors R-2501 through R-2505; bakelite, 4-3/4" x 1-7/8" x 1/8"; complete with 6 terminals.	Mounting board for Resistors R-2501 through R-2505.	H.B. Jones No. 6-1 Spec. Munston 263-137
E-2502	3G1250-12.19	STAND-OFF INSULATOR: Ceramic 3/4" x 3/8" dia.; tapped No. 6-32 axial mounting hole at each end.	Resistor board mounting supports	JAN Type NS4W0106
E-2503	3Z3269-34	COUPLING: Ceramic ring; two metal hubs with two set screws.	Insulated coupling between variometer and knob	Stewart-Warner 565365 General Electric ML7461439-5 Munston 263-136

TABLE OF PARTS (Cont'd)

NOTE: Parts listed which are indicated by a * sign in column 2 are not available as spare parts and are listed for reference purposes only.

MODEL: RADIO TRANSMITTING SET AN/ART-13A MAJOR ASSEMBLY: ANTENNA LOADING UNIT CU-32/ART-13A

Reference Symbol	Army Stock Number Navy Stock Number British Ref. Number	Name of Part and Description	Function	Mfr. and Desig. or Standard Type	Cont. or Govt. Dwg. or Spec. No.
E-2504	2Z9402.215	FEED-THROUGH ASSEMBLY: Antenna consisting of a 9" x 6" x 1/8" mycalex plate, and binding posts J-2506 and J-2507.	ANTENNA posts	Stewart-Warner 565105 General Electric ML-7102419-1 Munston 263-103	Stewart-Warner 565105 Munston 263-109
E-2505	3G1905-2	FEED-THROUGH ASSEMBLY: Supplied with binding post J-2503; ceramic; 3-1/8" dia. x 1" thk., three 0.154" dia. mtg. holes; bowl shape.	HF IMPUT terminal	Stewart-Warner 565580 General Electric ML-7104208-1 Munston 263-110	Stewart-Warner 565580 Munston 263-110
E-2506		FEED-THROUGH, INSULATOR ASSEMBLY: Consists of E2506-A and E-2506-B.			
E-2506-A	3G1000-4.1	FEED-THROUGH INSULATOR: Ceramic; female; 1/2" high; top dia. 3/4", bottom dia. 7/8".	Female insulator used with binding post J-2502	Centralab X-88W	Stewart-Warner 564882 Munston 263-134
E-2506-B	3G100-56.1	FEED-THROUGH, INSULATOR: Ceramic; male; 7/8" x 7/8" max. dia.	Male Insulator used with binding post J-2502		Stewart-Warner 564331 Munston 263-133
E-2508	2Z5786.37	KNOB: Complete with two set screws; bakelite 2-1/4" x 13/16" x 11/16"; black finish with white arrow.	Knob for S-2501 control "Q"	Stewart-Warner 565338 General Electric ML7891557-2	Stewart-Warner 565338 Munston 263-127
E-2509	2Z5822-125	KNOB: Complete with two set screws; less dial. 1" thk. x 2" dia.; bakelite, black.	Knob for L-2501 control "R"	Stewart-Warner 565308 ML-7461554-2	Stewart-Warner 565308 Munston 263-132
E-2510	3G1100-74.1	STAND-OFF: Ceramic; 3-15/32" x 1/2" x 1/2"; one axial tapped No. 10-24 mounting hole on one end; one 0.196" radial mounting hole 5/16" from other end; 4 used; part of L-2502.	L-2502 mounting insulators	Centralab General Electric 7101296-1	Stewart-Warner 565185 Munston 263-131
E-2511	3G110026.3	STAND-OFF: Ceramic; 1-5/8" x 3/8" x 3/8"; one axial tapped hole 7/32" from other end; one 0.196" radial mounting hole 7/32" from other end; part of L2502.	L-2502 mounting insulators	Amer. Lava Corp. Isolanite	Stewart-Warner 565290 Munston 263-130
E-2512	3G1100-104.4	STAND-OFF: Ceramic; 5-7/8" x 1/2" x 1/2"; one axial tapped No. 8-32 and two radial 0.173" mounting holes on one end; two radial 0.196" mounting holes on other end; part of relay K-2501.	Insulator between S-2504 and relay K-2501		Stewart-Warner 565141 Munston 263-129
E-2513	3G1100-100	STAND-OFF: Ceramic; 6-1/4" x 1/2" x 1/2"; axial, tapped No. 8-32 mounting hole on one end; 0.150" radial hole, 1/4" from other end.	S-2503 support post		Stewart-Warner 565461 Munston 263-139
E-2514	*	STAND-OFF: Ceramic; 1" x 3/8" x 3/8"; axial, tapped No. 8-32 mounting hole at each end, part of L-2501.	H.V. IMPUT conductor support	JAN type NS4U1108	
E-2515	3G1200-32.3	RING: Ceramic; O.D. 2"; I.D. 1-1/4"; 1/4" thk; two 0.154" dia. mounting holes; two tapped No. 6-32 mounting holes.	Used on L-2501 knob mechanism	Amer. Lava Corp.	Stewart-Warner 565236 Munston 263-128

E-2516	2Z5786.37	KNOB: Same as E-2508.	Knob for S-2502 control "p".	Stewart-Warner 565114 Munston 263-141
E-2517	2Z5786.37	KNOB: Same as E-2508.	Knob for S-2503 Control "D".	Stewart-Warner 565245 Munston 263-126
E-2518	*	SHAFT ASSEMBLY: Supplied with spring; 4-27/32" long; bakelite rod between end pieces.	Connecting rod between S-2504 and relay K-2501	Stewart-Warner 565240 AN3195-1
E-2519	*	KNOB: Black composition, brass shaft, 1-3/8" x 5/8" dia. shaft threaded No. 10-24 thread.	Lock knob	
E-2520	2Z8609-11	SNAP SLIDE: Stainless steel 1-15/32" long x 9/16" wide x 1/2" high; consists of 1 latch, 1 latch guide, rivet, 1 washer.		
E-2521	3G1450-16.1	STAND-OFF: 1-5/8" x 1/2" x 1/2"; 2 axial tapped 8-32 mtg. holes at each end.		Stewart-Warner 565575 Munston 263-124
E-2522	3G1100-33	STAND-OFF: Ceramic; 2-1/16" x 1/2" x 1/2"; No. 8-32 axial tapped hole at one end; 0.196" radial hole approx. 1/4" from other end.		Stewart-Warner 565601 Munston 263-123
E-2523	3G1450-16	STAND-OFF: Ceramic.		
H-2501	*	VERNIER MECHANISM: 1-11/64" x 2-9/16" dia.	Variometer speed reducer	JAN type NS4U1008 National Co. Stewart-Warner 565303 Munston 263-121
H-2502	*	COUPLER: 2" x 1/2" x 13/32" thk.	Used with insulated coupler	Stewart-Warner 565303 General Electric Cannon-Elec. WK-C3-32S-3 Munston 263-142
J-2501	2Z8673.42	CONNECTOR: Male; three contacts; wall mounting; two No. 10 contacts; one No. 16 contact; four 0.120" mounting holes, 0.729" between mtg/c; screw cable connector lock.	28 volt connection for K-2501 relay	
J-2502	3Z741-13	POST, BINDING: Same as J-117.	L. F. INPUT terminal	
J-2503	3Z741-13.2	POST, BINDING: Same as J-110.		
J-2504	3Z737-32	POST, BINDING: Same as J-113.		
J-2505	2Z8799-239	CONNECTOR: Female; 1" x 1-1/16" thk., four 0.120" dia. mounting holes.		
J-2506	*	POST, BINDING: Push type; black bakelite cap; keyed pin; 1-3/16" x 1/2" dia.; supplied with E-2504.	Antenna Post	Amer. Phenolic 83-1R Signal Corps SO-239 Stewart-Warner 565371 Munston 263-143
J-2507	*	POST, BINDING: Same as J-2506.		
K-2501	2Z7598-52	RELAY: Supplied with S-2504, E-2512, and E-2514; two coils connected in series used; nominal voltage 28 volts; coil resistance 26.1 ohms; approx. 5" wide x 8" high x 2-1/2" thk.; switch description under S-2504.	Antenna load connecting relay	R. B. M. Mfg. Co. 30300 Munston 263-106 Stewart-Warner 565200 Munston 263-107
L-2501	2Z9629-37	VARIOMETER ASSEMBLY: Consists of rotor stator and coupling coil; approx. 9-1/2" x 4-9/16" dia.; bakelite coil forms.	Antenna Loading	Stewart-Warner 565200 General Electric ML-7767107-1G Islip Transformer & Co. 47G47369
L-2502	3C1075-3	COIL, R. F. Single Winding; three taps; bank wound; 240 turns; mica tubing; supplied with support insulators; approx. 7" x 4-1/4" x 5" high.	Antenna Loading	Stewart-Warner 565140 General Electric ML-7767115-1 Islip-Transformer Co. 47D47391

TABLE OF PARTS (Cont'd)

NOTE: Parts listed which are indicated by a * sign in column 2 are not available as spare parts and are listed for reference purposes only.

MODEL: RADIO TRANSMITTING SET AN/ART-13A MAJOR ASSEMBLY: ANTENNA LOADING UNIT CU-32/ART-13A

Reference Symbol	Army Stock Number Navy Stock Number British Ref. Number	Name of Part and Description	Function	Mfr. and Desig. or Standard Type	Cont. or Govt. Dwg. or Spec. No.
M-2501	3F1005-51	METER: Ammeter, thermo R. F., 0-5 amperes, 2-1/2" round.	Antenna loading meter	JAN type MR25B05RLAA	
N-2501	*	DIAL: Aluminum; 2-1/2" dia; one half of dial calibrated 0-100; six 1/8" dia. mounting holes.	Variometer dial	Chicago Thrift Co. Munston 263-119	Stewart-Warner 565302 Munston 263-119
O-2502	*	DISC ASSEMBLY: Semi-circular; 3" dia. x 1/4" thk.	Part of dial mechanism	Stewart-Warner 565227 General Electric Munston 263-118	Stewart-Warner 565227 Munston 263-118
R-2501	3RC21BF185K	RESISTOR: Fixed, carbon 1 watt; 1.8 megohms $\pm 10\%$ max. dimensions 1.280" x 0.310" dia.; 1-1/2" axial wire leads.	Capacitor discharging network	JAN Type RC31BF185K	
R-2502	3RC21BF185K	RESISTOR: Same as R-2501.	Capacitor discharging network		
R-2503	3RC21BF185K	RESISTOR: Same as R-2501.	Capacitor discharging network		
R-2504	3RC21BF185K	RESISTOR: Same as R-2501.	Capacitor discharging network		
R-2505	3RC21BF185K	RESISTOR: Same as R-2501.	Capacitor discharging network		
S-2501	3Z9826-54.2	SWITCH: Two bank; four position; switch body approx. 5-31/32" x 2-3/4" dia.; thread tapped No. 6-32 mounting bushings; operated by control "Q".	Variometer switch	Centralab Ucinite General Electric ML-7472223-1 Munston 263-103	Stewart-Warner 565250 Munston 263-103
S-2502	3Z9826-54.1	SWITCH: Two bank; five position switch body approx. 6-25/64" x 3-7/8" dia.; four tapped No. 6-32 mounting bushings; operated by Control "p".	Antenna load coil switch	Centralab Ucinite General Electric ML-7472073-1 Munston 263-104	Stewart-Warner 565370 Munston 263-104
S-2503	3Z9826-54	SWITCH: Four bank; two position; switch body approx. 9-1/2" x 3-7/8" dia.; four tapped No. 6-32 mounting bushings; ceramic support post in rear; operated by control "O".	Antenna switch	Centralab Ucinite General Electric ML-7663336-1 Munston 263-105	Stewart-Warner 565450 Munston 263-105
S-2504	2Z7598-52/1	SWITCH: Vacuum; S.P.D.T.; 4" x 3-1/2" x 1-1/2"; less holder, cap and sphere; glass envelope.	Antenna load connecting switch	General Electric K-7104031 Sperti IS22	Stewart-Warner 565198

MAJOR ASSEMBLY: PANEL MX-128/ART-13

P-402 2Z7227-2 CONNECTOR: Same as P-2601.
 R-402* 3Z6002H8-6 RESISTOR: Fixed; wire wound; 28 ohms $\pm 10\%$; 10 watts.

Low frequency oscillator connector to transmitter
 Filament substitute resistor
 Stewart-Warner 565705
 Stewart-Warner 565705

MAJOR ASSEMBLY: MOUNTING MT-198/ART-13A

A-2901 MOUNT, VIBRATION: 6 lb. load rating; 2-1/4" x 2-1/4" x 1-1/16" high; 4 mtg holes 0.196" diam. on 1-3/4" x 1-3/4" centers. AF Stock No. 6600-574865-4.
 U. S. Rubber 6200P (30 Durometer)

*Sometimes supplied as two resistors in series.

MODEL: RADIO TRANSMITTING SET AN/ART-13B

MAJOR ASSEMBLY: RADIO TRANSMITTER T-412/ART-13B

C-150 CAPACITOR: Fixed; ceramic; 25 mmf $\pm 10\%$ tolerance; 500 v DC working; zero temp coefficient, ± 30 mmf; 0.812" lg x 0.25" dia; 2 terminals, axial wire lead type; terminal mounted.
 Erie Resistor Co. Style No. NP030L Communications Co., Inc. 130-25

E-147 3320-332065614 INSULATOR, Standoff: cylindrical pillar shape; white L-5A steatite ceramic; glazed, excepting ends; over-all dim. 1" lg x 3/8" dia, 6-32 tapped at each end.
 American Lava Co. No. 1706 Communications Co., Inc. 276-016

J119 88 50-586060 CONNECTOR, Receptacle: 15 flat female contacts, 5 amp. 45 volt rating; polarized; rectangular; straight; black bakelite body; over-all dim. 1-5/8" lg x 11/16" wide x 1/2" high.
 Howard B. Jones Co. No. S-315-AB Communications Co., Inc. 551-138

K-106 RELAY, Armature: contact data: single break, 24 v non-inductive load, 3 amp non-inductive load; coil data: 1 winding, DC, 300 ohms, 24 v operating, 0.8 amp operating current; terminal data: 6 contact terminals, 2 coil terminals, all solder lug type; continuous duty; over-all dim. 1-15/32" lg x 1-3/16" high x 5/8" wide.
 Signal Engineering Co. Series 80 Communications Co., Inc. 380-026

R-138 RESISTOR, Fixed, Wire-wound: inductive winding; 100 ohms $\pm 15\%$; 10 watts; vitreous enamel coating; 2 solder lug terminals; dim. excluding terminals 1" lg x 1/2" OD.
 ITE Circuit Breaker Co. Type 100E 410-100
 Part No. RW-30J-101

R-139 RESISTOR, Fixed, Wire-wound: inductive winding; 6,000 ohms; 20 watts; vitreous enamel coated; terminal mounted; 2 solder lug terminals; dim. excluding terminals 2" lg x 9/16" OD.
 Ward Leonard Type T-6000-WL Communications Co., Inc. 422-6000

S-107E SWITCH, Rotary: 1 section; 2 position; 1 pole, 2 stator contacts per section; 2 throws; brass contacts, silver plated; phenolic wafer section; over-all dim. 1-3/16" lg x 1-19/32" wide x 1-7/8" high; single hole mounting; flatted shaft; solder lug terminals.
 LOCAL/REMOTE switch.
 Oak Mfg. Co. No. 38600-H1 Communications Co., Inc. 510-043

S-109B SWITCH WAFER SECTION: Rotary; 1 section; 12 switch positions; 1 pole; 10 stator contacts; brass contacts, silver plated; phenolic body; dim. excluding contact terminals 1-7/8" lg x 1-19/32" wide x 0.075" thick.
 Channel Switch (addition to existing S109 switch)
 Oak Mfg. Co. No. 38601-H Communications Co., Inc. 510-042

C 151 3330-37 6016800 CAPACITOR: Fixed; mica; 220 micromicrofarads
 Padder

H-121 33 20-33 126 5831 POST, TERMINAL
 C-151 condenser mounting post

TABLE OF PARTS (Cont'd)

NOTE: Parts listed which are indicated by a # sign in column 2 are not available as spare parts and are listed for reference purposes only.

Reference Symbol	Army Stock Number Navy Stock Number British Ref. Number	Name of Part and Description	Function	Mfr. and Desig. or Standard Type	Cont. or Govt. Dwg. or Spec. No.
S-117	3360-395822 100	SWITCH: Toggle; S.P.S.I.	1670 Kc. crystal selector switch	Hart & Hageman Co. 20994	
S-604		SWITCH: Same as S-117	A-B channel switch		
MODEL: RADIO TRANSMITTING SET AN/ART-13B					
MAJOR ASSEMBLY: CDA-T CRYSTAL CONTROLLED OSCILLATOR UNIT					
C801		CAPACITOR, Fixed, ceramic dielectric: 25 mmf $\pm 10\%$; 500 v DC working; zero temp coefficient ± 30 mmf tolerance; body insulated, phenolic jacket; 2 terminals, axial wire lead type; terminal mounted; dim. 0.812" lg x 0.250" dia.	Screen grid capacitor V-801	Erie Resistor Corp. Style NP030L	Communications Co., Inc. 130-25
C802		CAPACITOR, Fixed, ceramic dielectric: 3.5 mmf $\pm 10\%$; 500 v DC working; zero temp coefficient; body insulated, phenolic jacket; 2 terminals, axial wire lead type; terminal mounted; dim. 0.562" lg x 0.250" dia.	Low Frequency Oscillator coupling	Erie Resistor Corp. Style NP0-120K	Communications Co., Inc. 130-3-5
C803		CAPACITOR, Fixed, mica dielectric: 10,000 mmf $\pm 10\%$; 600 v DC working; molded low-loss bakelite case; dim. 1-1/4" lg x 1-1/8" wide x 11/32" deep; 2 solder lug type terminals; salt water immersion resistant.	Screen grid bypass V-802	Cornell-Dubilier Type 4LS	Communications Co., Inc. 89-040
C804		CAPACITOR: Same as C803	Cathode bypass V802		
C805		CAPACITOR, Fixed, mica dielectric: 1,000 mmf $\pm 10\%$; 600 v DC working; molded low-loss bakelite case; dim. 1-1/4" lg x 1-1/8" wide x 11/32" deep; 2 solder lug type terminals; salt water immersion resistant.	Grid capacitor V-802	Cornell-Dubilier Type 4LS	Communications Co., Inc. 89-029
C806	3330-056200421	CAPACITOR, Fixed, mica dielectric: 250 mmf $\pm 10\%$; 500 v DC working; temp coef -20 to $+100$ parts/million/ $^{\circ}$ C; molded low-loss bakelite case; salt water immersion resistant; case dim. 11/16" lg x 7/16" wide x 7/32" deep; 2 terminals, radial wire lead type; terminal mounted.	Grid capacitor V-802	Arco Electronics Inc. Type CM-19	Communications Co., Inc. 81-019
E801	3320-331751034	INSULATOR, Feedthru: ceramic, L-5A Steatite, white, glazed finish; double ended conical; MBCA Ref Dwg Group 9, item code no. 172; dim. D-5/8", H1-3/8", H2-5/8", L-1-1/4", S-6-32 thread; mounted by 6-32 screw through feedthru.	Low frequency oscillator output insulator	American Lava Corp. No. 1173	Communications Co., Inc. 271-010
E802		INSULATOR, Bowl: ceramic, L-5A Steatite, white; glazed finish; round, counterbore, MBCA Ref Dwg Group 9, item code no. 123; dim. D-7/16", E-1/8", F-9/32", H-5/32", K-1/8", L-1/4"; mounted through center hole.	High frequency oscillator output insulator	American Lava Corp. No. 10166	Communications Co., Inc. 271-008

E803		INSULATOR, Bushing: ceramic, L-5A Steatite, white; glazed finish; round shank; MBCA Ref Dwg Group 9, item code no. 76; dim. D-7/16", E-1/8", G-1/4", H-9/64", L-11/32", R-1/32"; -45 deg chamfer; mounted through center hole.	-High frequency oscillator output insulator	American Lava Corp. No. 10167	Communications Co., Inc. 271-009
K801	3380-294951000	RELAY, Armature: normally open, single break; RF; 1 winding, inductive, DC, 40 ohms; 6 v operating; 2 terminals on contacts, 2 terminals on coil; continuous duty; over-all dim. 1-1/4" lg x 1-1/16" wide x 11/16" high; mounted by 2 holes in frame, 4-40 tapped, spaced 7/16" C to C.	Channel 1 switching relay	Western Electric Co. Type ESO-691209-1	Communications Co., Inc. 388-025
K802		RELAY: Same as K801.	Channel 2 switching relay		
K803		RELAY: Same as K801.	Channel 3 switching relay		
K804		RELAY: Same as K801.	Channel 4 switching relay		
K805		RELAY: Same as K801.	Channel 5 switching relay		
K806		RELAY: Same as K801.	Channel 6 switching relay		
K807		RELAY: Same as K801.	Channel 7 switching relay		
K808		RELAY: Same as K801.	Channel 8 switching relay		
K809		RELAY: Same as K801.	Channel 9 switching relay		
K810		RELAY: Same as K801.	Channel 10 switching relay		
K811	3380-511120-6175	RELAY, Armature: single break, DC, 24 v, 7 amp; 1 winding, inductive, DC, 410 ohms, 24-28 v operating; 6 terminals on contacts, 2 terminals on coil; continuous duty; over-all dim. 2" lg x 1-3/16" wide x 1-1/2" high; mounted by bracket with 2 holes 6-32 tapped, spaced 1.438" C to C.	A-B channel switching relay	Advance Electric & Relay Co. No. 1088	Communications Co., Inc. 388-039
L801	3340-060705940	COIL, Radio frequency: 2.5 mh at 1,000 cycles, 44 ohms DC resistance; 100 ma; no. 36 AWG, copper conductor, enameled single nylon, 1 winding, 4 pie, universal winding, untapped, unshielded; ceramic form; coil dim. 3/4" lg x 1/2" dia; 2 terminals, cotter pin type; mounted by one no. 6-32 tapped hole on end.	Screen grid RF choke V-801	National Co. Type R-100S	Communications Co., Inc. 20-039
L802	3340-307672162	COIL, Radio frequency: 1.0 mh at 1,000 10 ohms DC resistance, 250 ma; no. 32 AWG, copper conductor, enameled single nylon, one winding, 3 pie universal winding, untapped, unshielded; ceramic form; coil dim. 3/4" lg x 17/32" dia; 2 terminals, cotter pin type; mounted by one no. 6-32 tapped hole, on end.	V-802 plate R-F choke	National Co. Type R-300S	Communications Co., Inc. 20-040

TABLE OF PARTS (Cont'd)

NOTE: Parts listed which are indicated by a # sign in column 2 are not available as spare parts and are listed for reference purposes only.

MODEL: RADIO TRANSMITTING SET AN/ART-13B MAJOR ASSEMBLY: CDA-T CRYSTAL CONTROLLED OSCILLATOR UNIT

Reference Symbol	Army Stock Number Navy Stock Number British Ref. Number	Name of Part and Description	Function	Mfr. and Desig. or Standard Type	Cont. or Govt. Dwg. or Spec. No.
L803		COIL, Radio Frequency: 0.7 to 1.2 mh; 250 turns no. 36 AWG copper conductor, single nylon enamel, one pie universal winding, untapped, unshielded; phenolic form; iron core; 7/16" dia x 1/4" lg; adjustable iron core tuning, screwdriver adjustment; mounted by one 1/4-28 threaded bushing.	V-802 variable plate R-F choke	Cambridge Thermionic Corp. Type LS3	Communications Co., Inc. 20-042
P801	88 50586180	CONNECTOR, Plug: 15 contacts, male, flat; polarized; straight type; over-all dim. 1-5/8" lg x 1-11/16" wide x 1/2" high; 5 amp rating, 45 v; rectangular shape body, bakelite; 2 mounting holes, 0.152" dia, 1-3/8" mounting center.	High frequency channel, filament and cathode connector	H. B. Jones Co. No. P-315-AB	Communications Co., Inc. 551-115
P802	88 50554576	CONNECTOR, Plug: 6 contacts, male, flat; polarized; straight type; over-all dim. 1" lg x 1-5/16" wide x 7/16" high; 5 amp rating, 45 v; rectangular shape body, bakelite; 2 mounting holes, 0.152" dia, 1" mounting center.	Low frequency cathode, filament and power connector	H. B. Jones Co. No. P-306-AB	Communications Co., Inc. 551-137
R801		RESISTOR, Fixed, composition: 100,000 ohms, $\pm 10\%$; 1/2 watt; F temp coef; dim. excluding terminals 13/32" lg x 1/8" dia; 2 terminals, axial wire lead type; salt water immersion resistant; insulated.	V-801 grid resistor	IRC Type BST-1/2	Communications Co., Inc. 404-100K Spec. JAN-R-11 Type RC20
R802		RESISTOR, Fixed, wire-wound: 44 ohms $\pm 5\%$; 20 watts; inductive winding; vitreous enamel coated; dim. excluding terminals 2" lg x 1/2" OD, 1/4" ID; 2 terminals, solder lug type; terminal mounted.	V-801 filament resistor	Ohmite Mfg. Co. No. 30372	Communications Co., Inc. 422-44
R803		RESISTOR: Same as R801.	V-802 grid resistor		
R804		RESISTOR, Fixed, composition: 22,000 ohms, $\pm 10\%$; 1 watt; F temp coef; dim. excluding terminals 23/32" lg x 1/4" dia; insulated; salt water immersion resistant; 2 terminals, axial wire lead type; terminal mounted.	V-802 screen grid resistor	IRC Type BTA-1	Communications Co., Inc. 406-22K Spec. JAN-R-11 Type RC30
S801		SWITCH, Toggle: single-pole, single-throw; 3 amp, 125 v AC; laminated phenolic body; over-all dim. excluding terminals, barriers, bushing and handle 29/32" lg x 7/16" wide x 7/16" deep; bat handle, 11/16" lg; 2 terminals, solder lug type; single hole mounting by 15/32" dia bushing, 32 thread.	A-B channel switch	Bud Radio, Inc. No. SW-1115	Communications Co., Inc. 521-001
S802		SWITCH: Same as S801.	VFO/XTAL switch		

S803	SWITCH, Rotary: 1 section; 4 position; non-"pile-up" type contact arrangement, 1 pole, 4 throws; brass contacts, silver plated; phenolic section; dim. 2-5/8" lg x 1-19/32" wide x 1-7/8" high; mounted by 3/8" lg x 3/8" dia — 32 thread bushing; flatted type shaft; solder lug terminals.	Low frequency crystal switching	Oak Mfg. Co. per Gables Engr. Dwg. A-0388	Communications Co., Inc. 510-041
V801	ELECTRON TUBE: pentode, glass envelope, T-5 1/2; 7 terminations, pin type; Type 1625.	High frequency oscillator	RCA Type 6AQ5	Communications Co., Inc. 720-6AQ5
V802	ELECTRON TUBE: pentode, glass envelope, ST 16; 7 terminations, pin type; Type 1625.	Low frequency oscillator	RCA Type 1625	Communications Co., Inc. 730-1625
X801	SOCKET, Electron tube: 7 contacts, phosphor bronze, cadmium plated; miniature; over-all dim. excluding terminals 27/32" lg x 0.800" dia; ceramic body; base shield type, top mounting; 2 mtg holes, 0.125" dia, spaced 0.875" C to C.	Socket for V-801	Elco Corp. No. 152 PHSPTD	Communications Co., Inc. 558-023
X802	SOCKET, Electron tube: 7 contacts, phosphor bronze, silver plated; oval shape; over-all dim. excluding terminals 2-5/16" lg x 1-13/16" wide x 1/4" high; ceramic body; mounted sub-chassis; 2 mounting holes, 17/64" slots, spaced 1-49/64" C to C.	Socket for V-802	E. F. Johnson Co. No. 122-227	Communications Co., Inc. 558-025
X803 thru X805	SOCKET, Crystal: 5/32" dia pins accommodated, 13/16" x 1/2" C to C; rectangular shape; top plate natural bakelite; bottom plate cloth bakelite; over-all dim. excluding terminals 1-5/8" lg x 1" wide x 7/64" thick; mounted below chassis; 3 mtg holes, 0.169" dia, spaced 5/8" x 1-5/16" x 1-5/16" C to C.	Sockets for low frequency crystals	Cinch Mfg. Co. No. 2886	Communications Co., Inc. 553-003
X806 X807	SOCKET, Crystal: 3/64" dia pins accommodated, spaced 1/2" C to C; rectangular shape; over-all dim. excluding terminals 2-1/4" lg x 1-11/16" wide x 5/16" high; molded plastic body; molded-in inserts; 4 mtg holes, 4-40 tapped, spaced 1-5/16" x 1-25/32" x 1-25/32" C to C.	Sockets for high frequency crystals	Molded Insulation Products Co. per Specs. of Aeronautical Communications Equip. Co., Coral Gables, Fla.	Communications Co., Inc. 553-010
X806A X807A	COVER, Crystal holder: acrylic plastic; over-all dim. 2-1/4" lg x 1-11/16" wide x 1/4" high; two 1/8" dia mtg holes, 1-5/16" C to C.	Hold-down covers for high frequency crystals	Molded Insulation Products Co. per Specs. of Aeronautical Communications Equip. Co., Coral Gables, Fla.	Communications Co., Inc. 553-010A

SECTION VIII
DRAWINGS

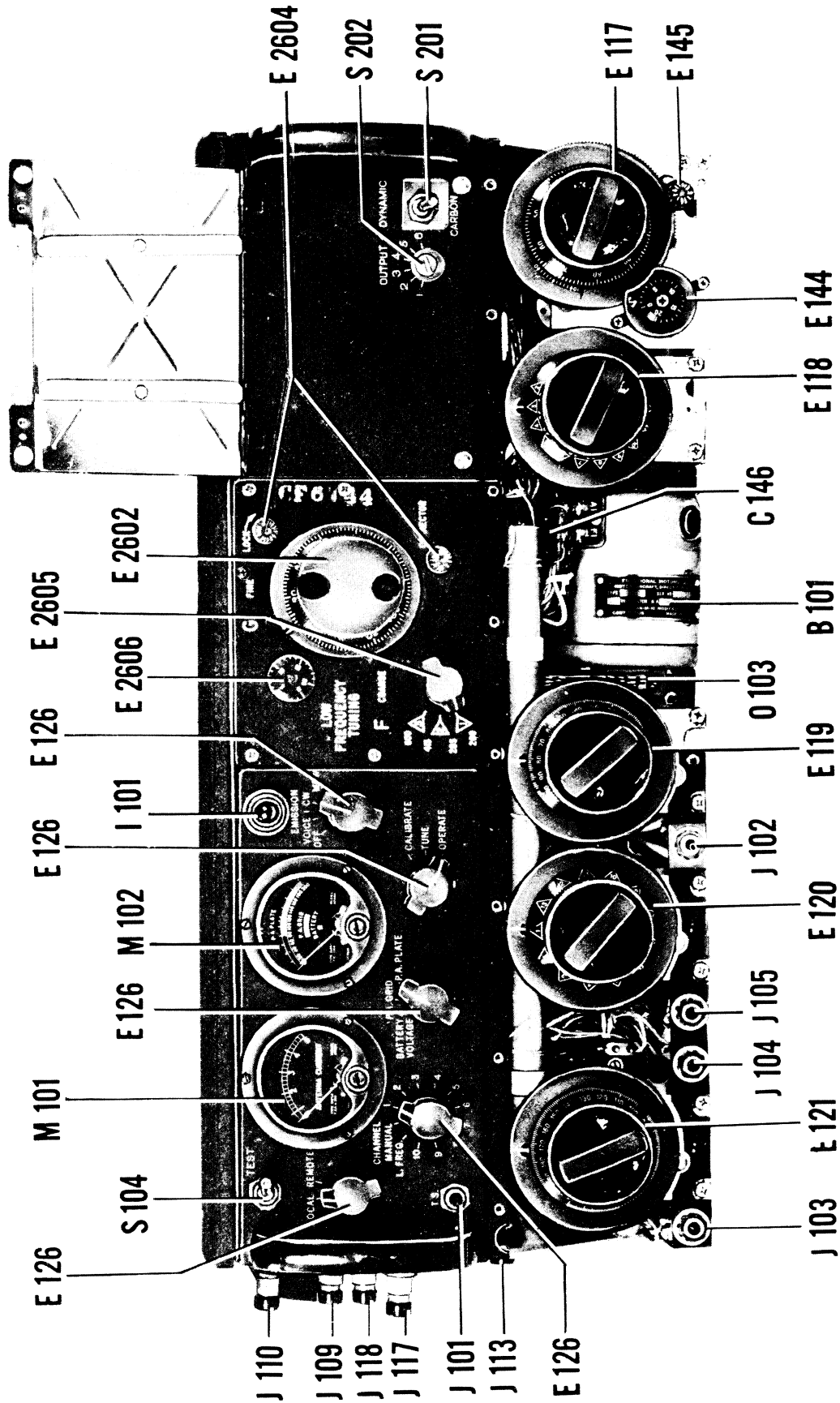

Figure 8-1. Radio Transmitter T-47A/ART-13 — Front View, Open

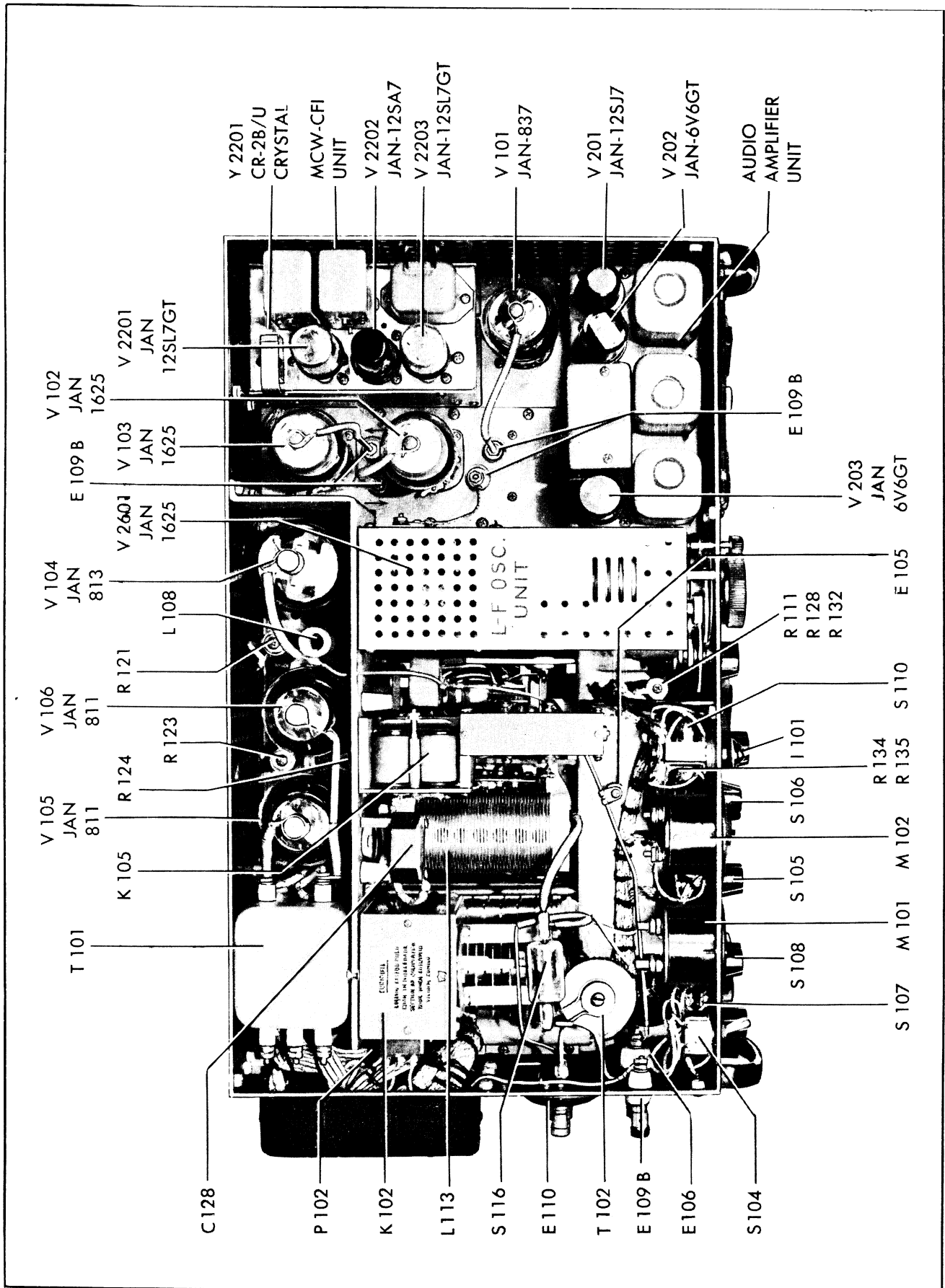

Figure 8-2. Radio Transmitter T-47A/ART-13 — Top View, Cover Removed

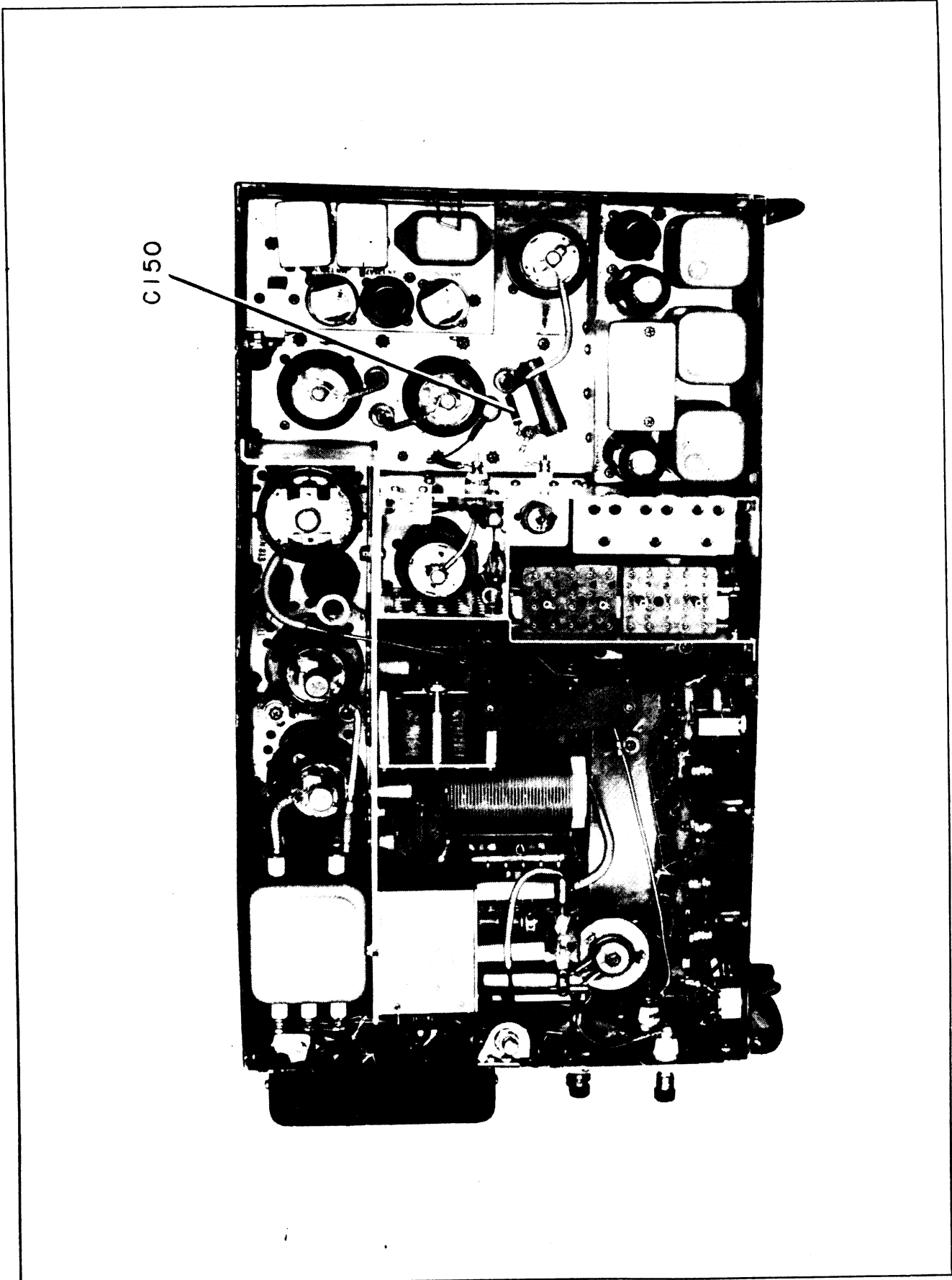

Figure 8-2A. Radio Transmitter T-412/ART-13B — Top View, Cover Removed

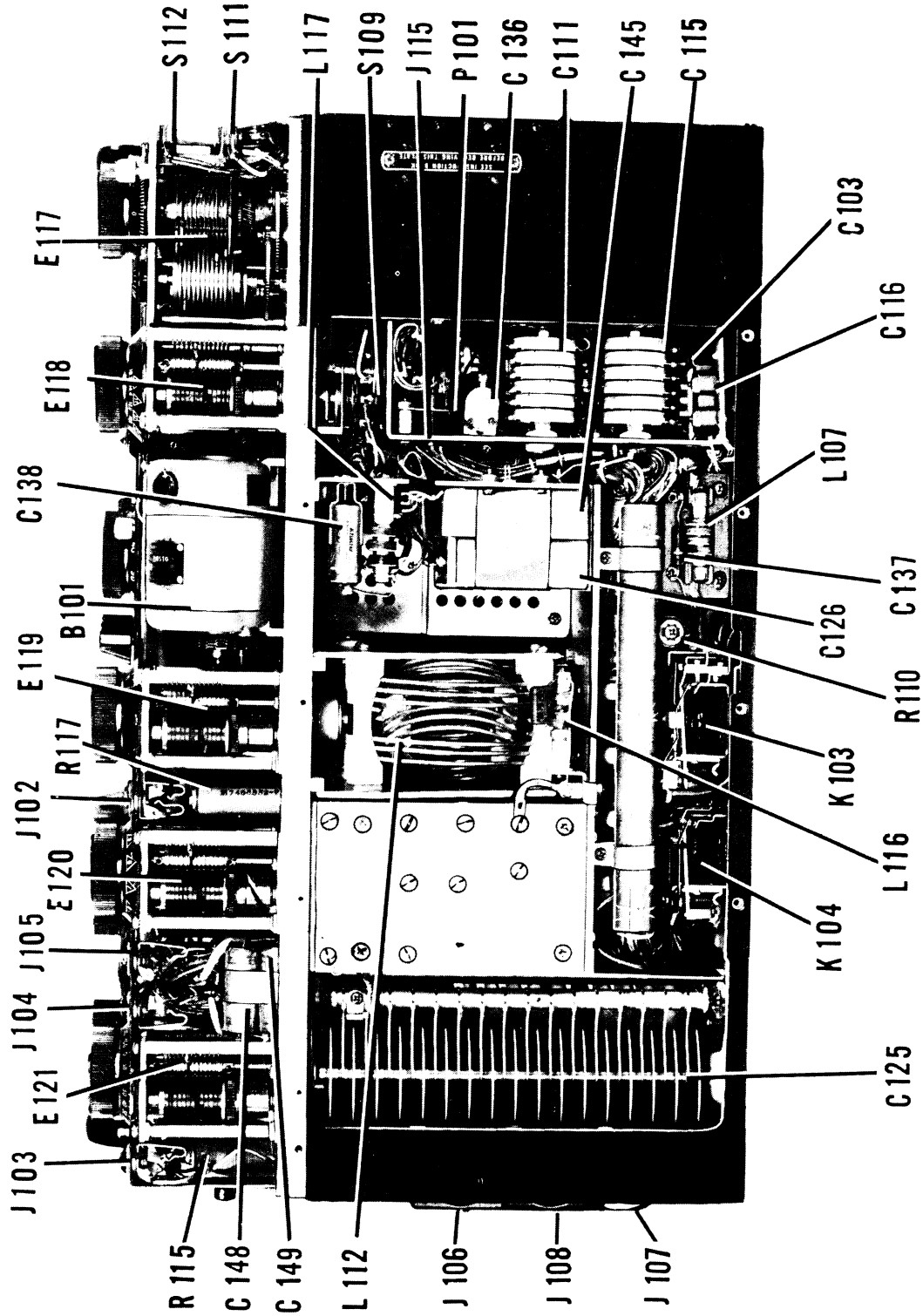

Figure 8-3. Radio Transmitter T-47A/ART-13 — Bottom View, Panel Removed

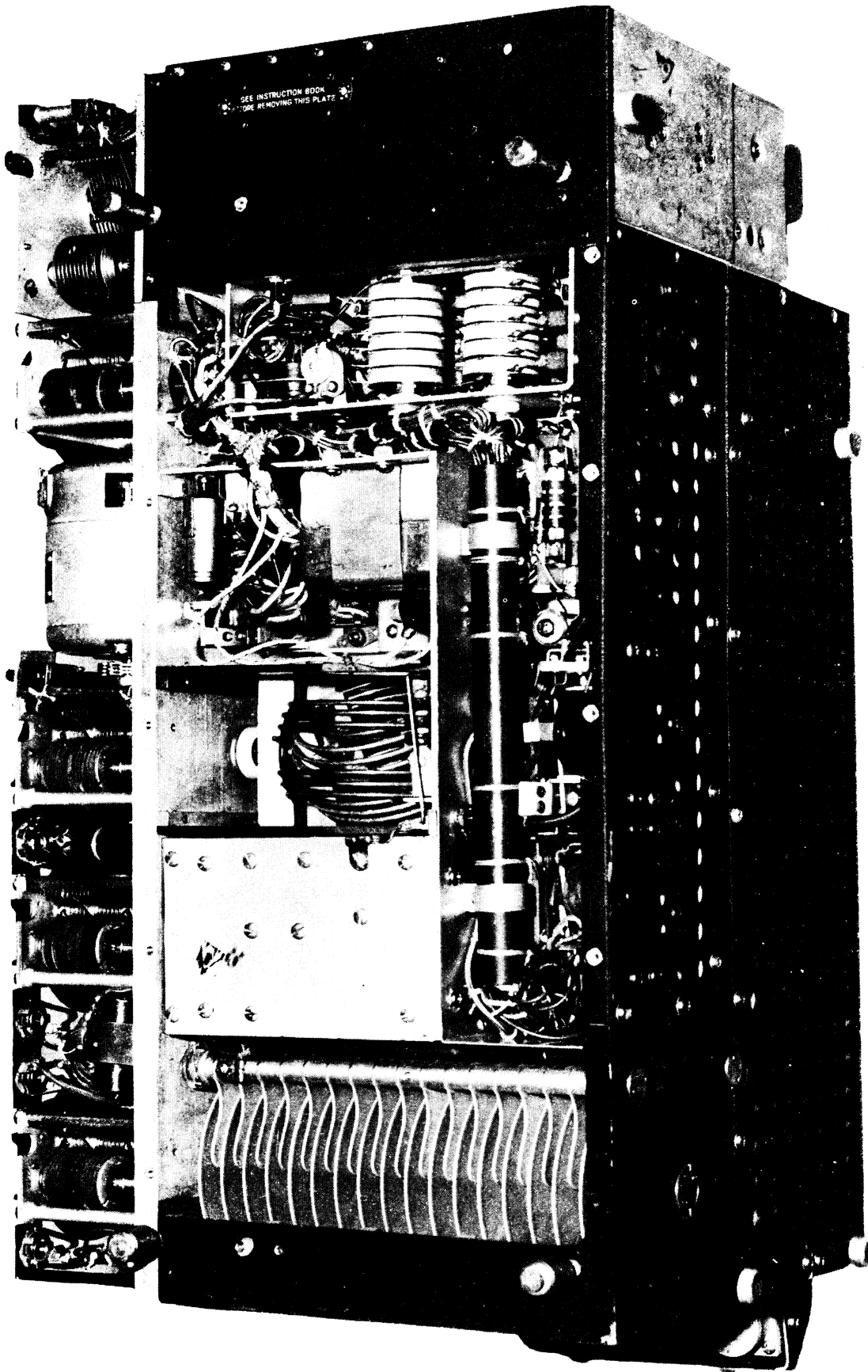

Figure 8-3A. Radio Transmitter T-4 12 / ART-13B — Bottom View, Panel Removed

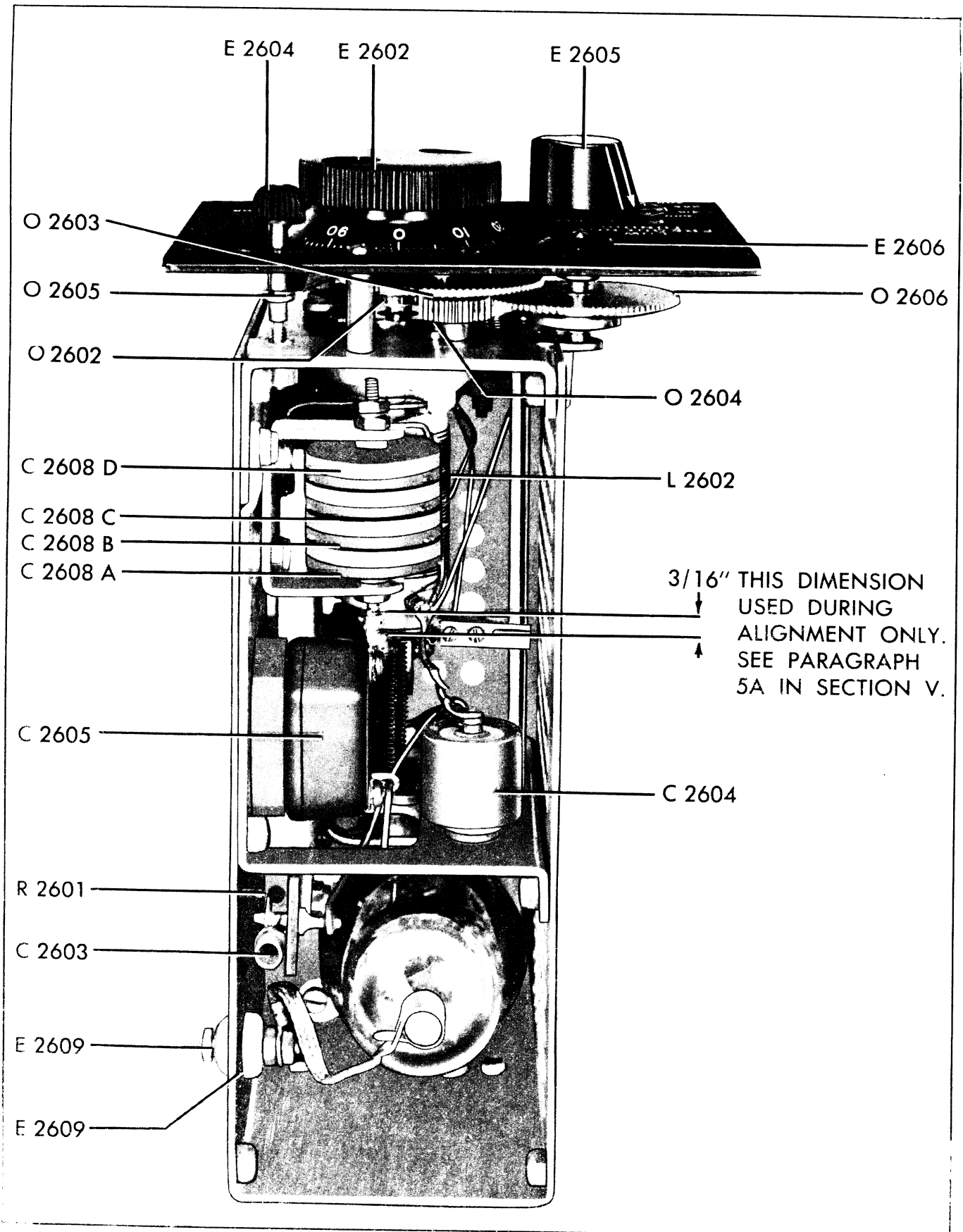

Figure 8-4. Low Frequency Oscillator Unit (Oscillator 0-17 ART-13A) — Top View, Open

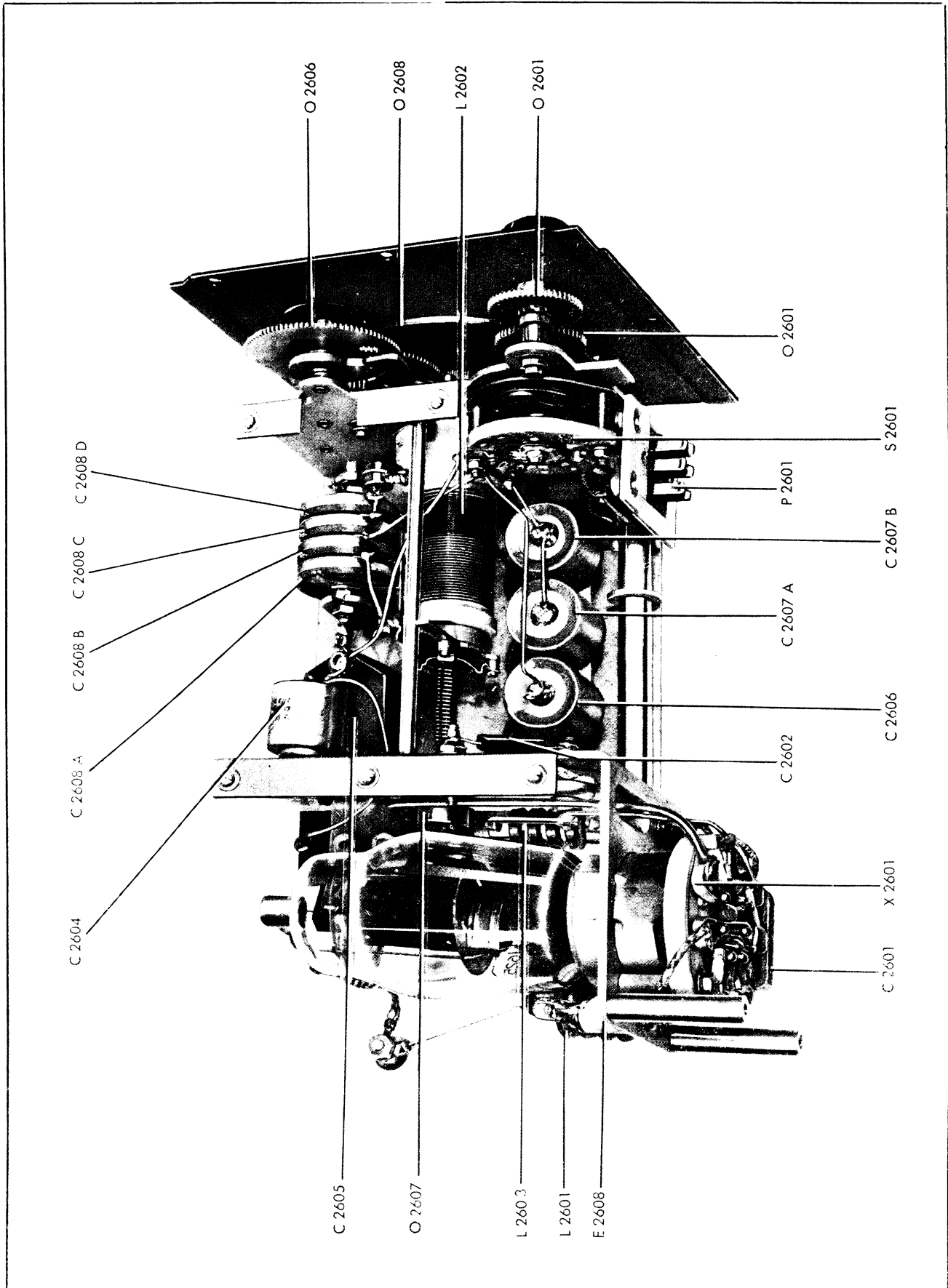

Figure 8-5. Low Frequency Oscillator Unit (Oscillator 0-17 ART-13A) — Bottom View, Open

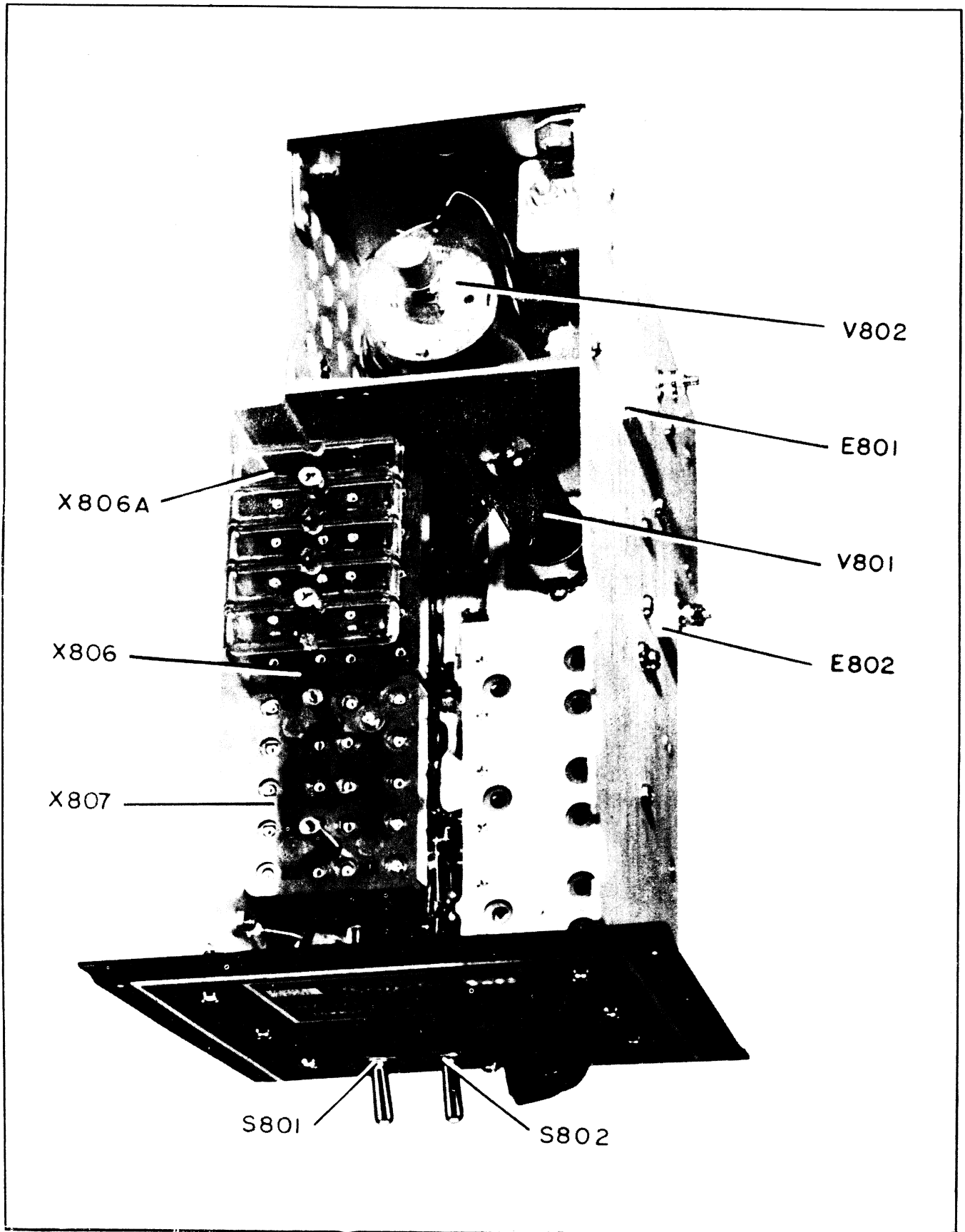

Figure 8-5A. Crystal Controlled Oscillator Unit (CDA-T) — Top View

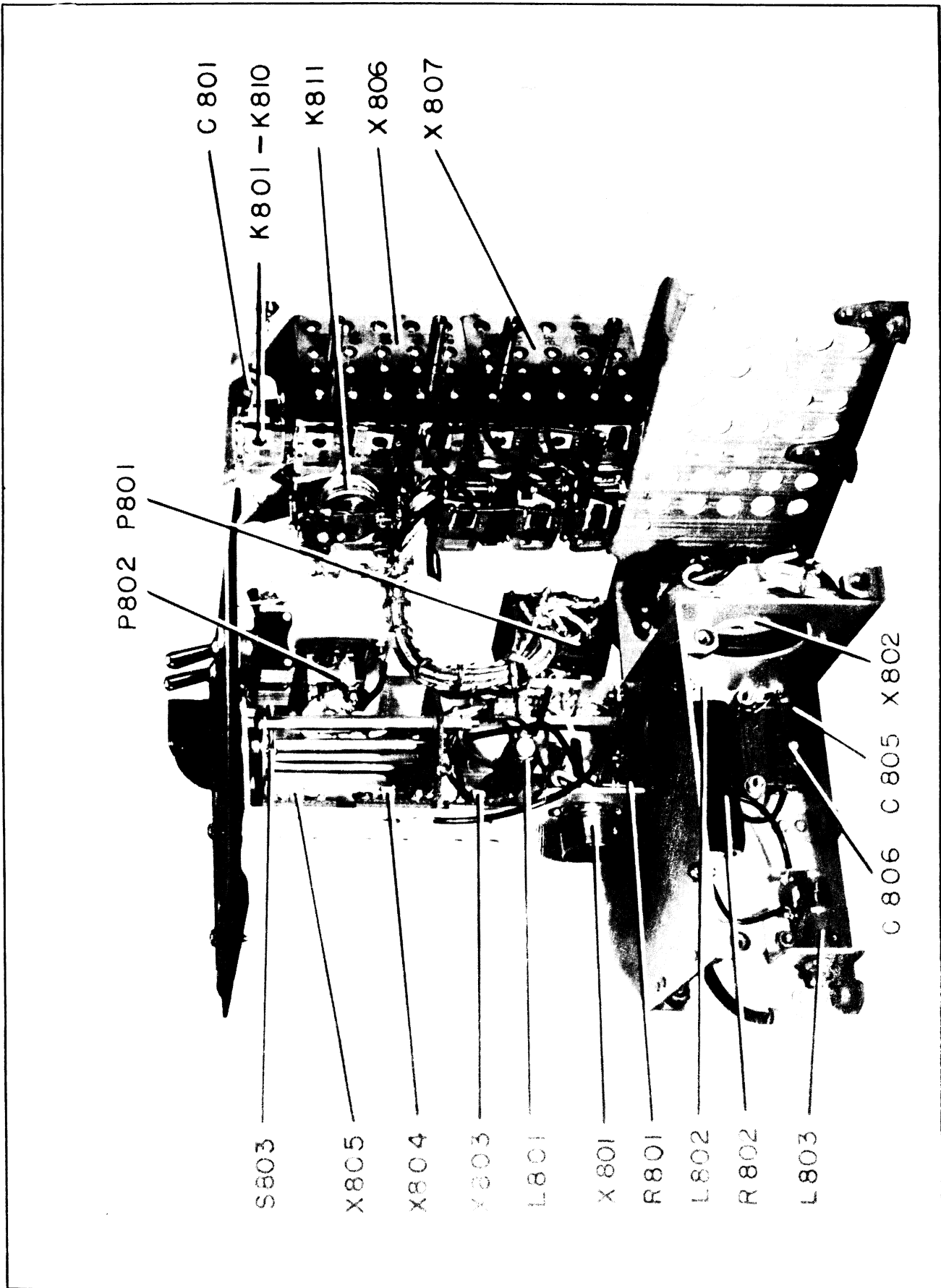

Figure 8-5B. Crystal Controlled Oscillator Unit (CDA-T) — Parts Identification

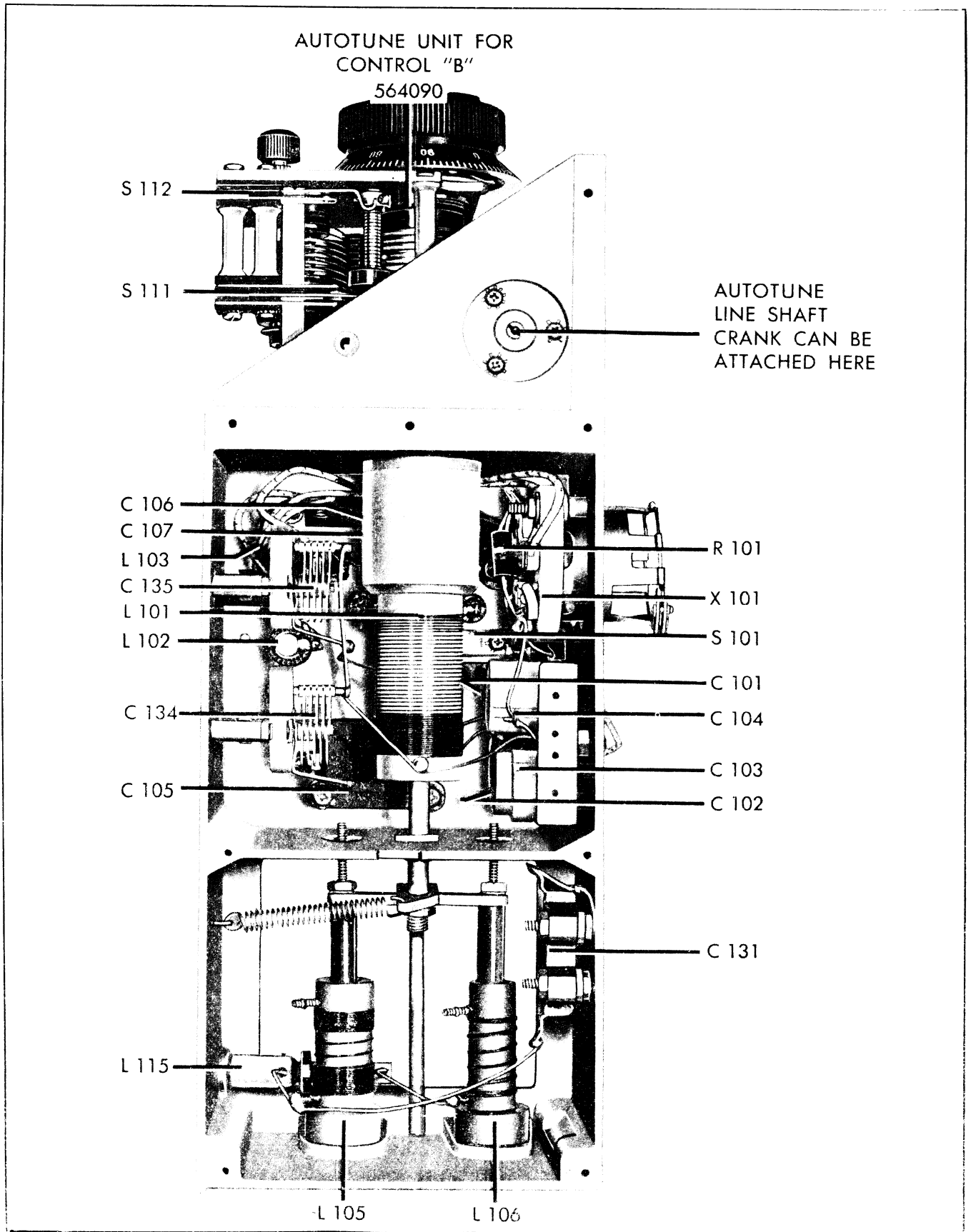

Figure 8-6. High Frequency Oscillator — Side View, Open

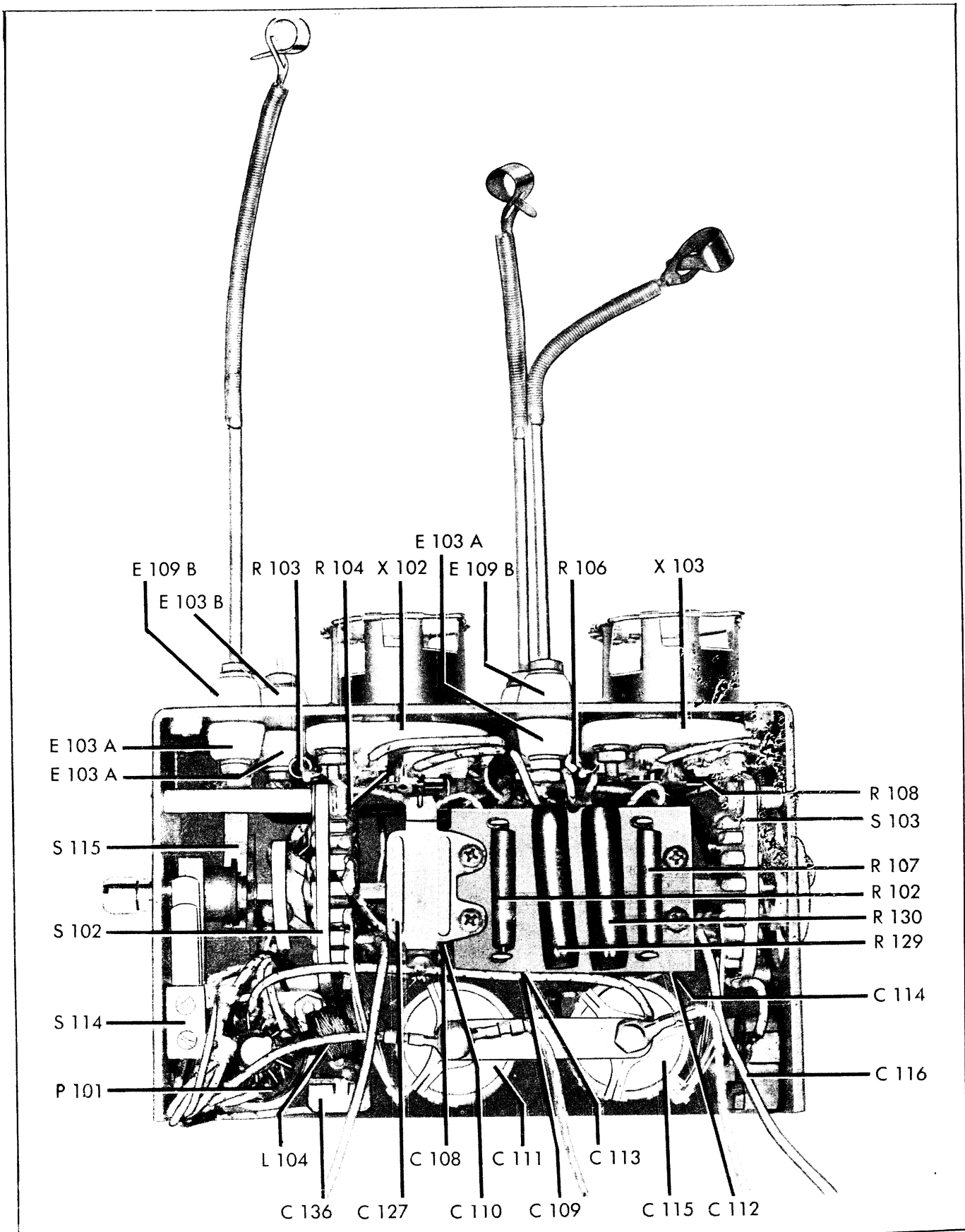

Figure 8-7. Frequency Multiplier — Side View, Open

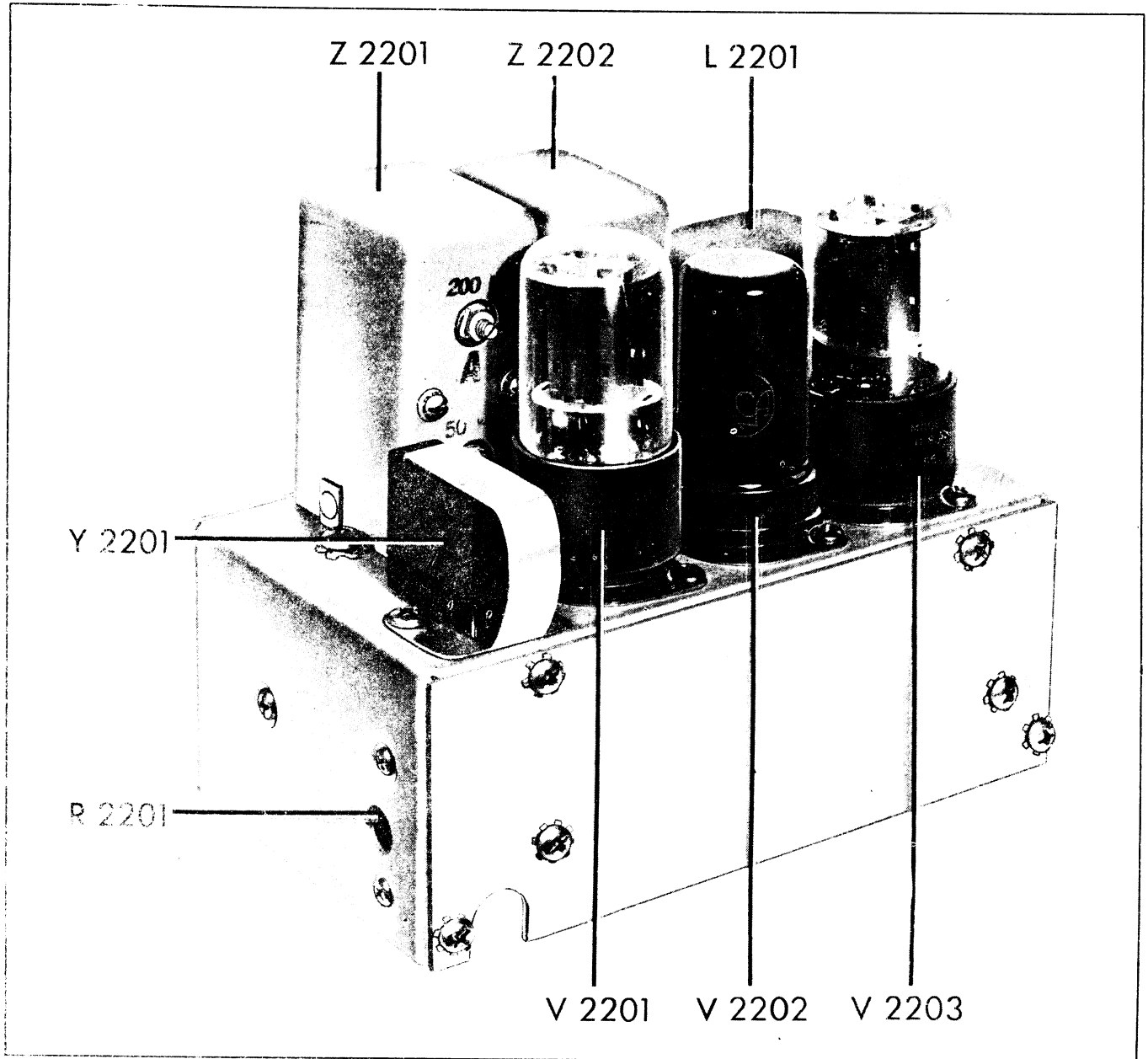

Figure 8-8. MCW-CFI Unit — Top View

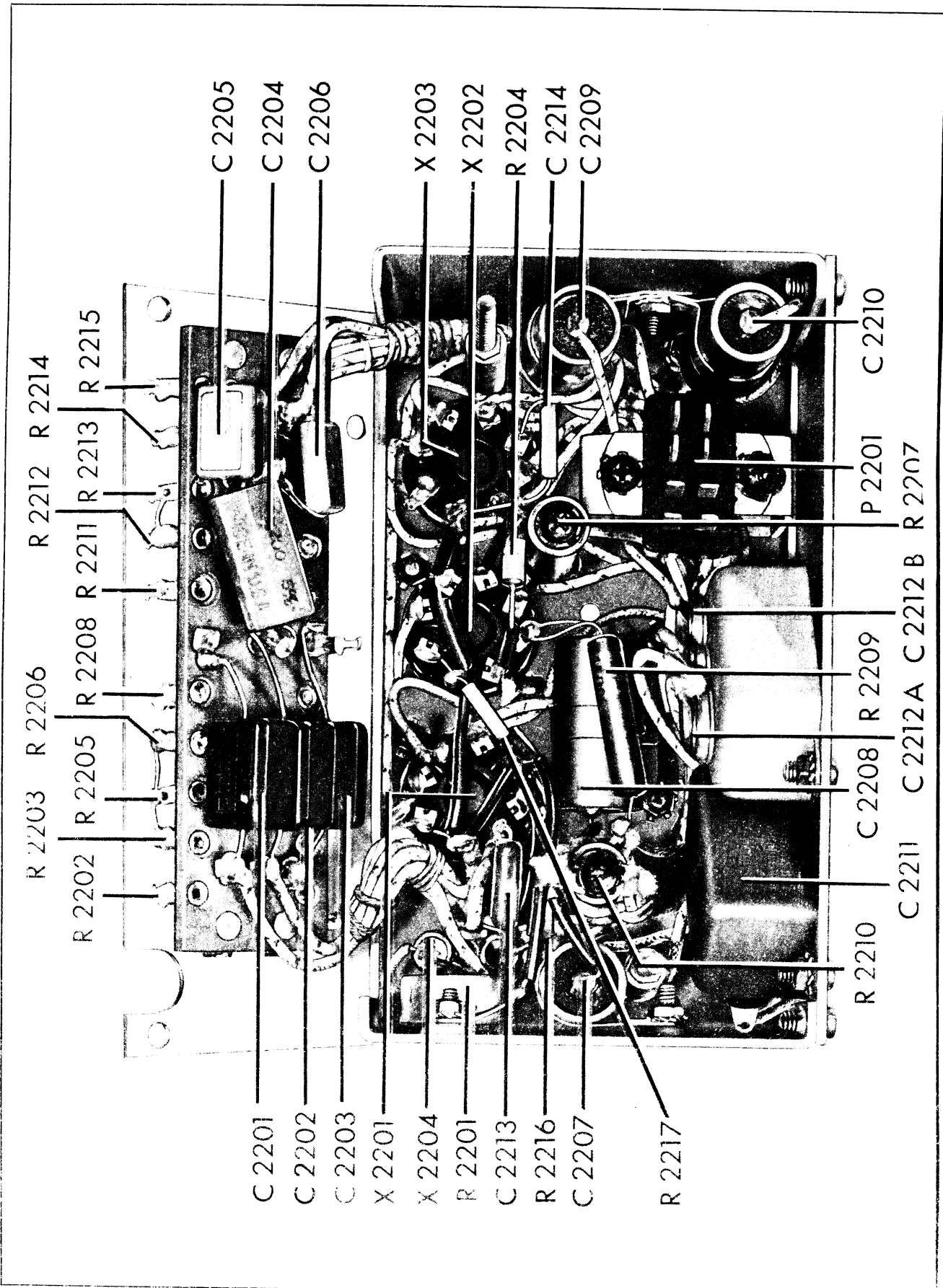

Figure 8-9. MCW-CFI Unit — Bottom View

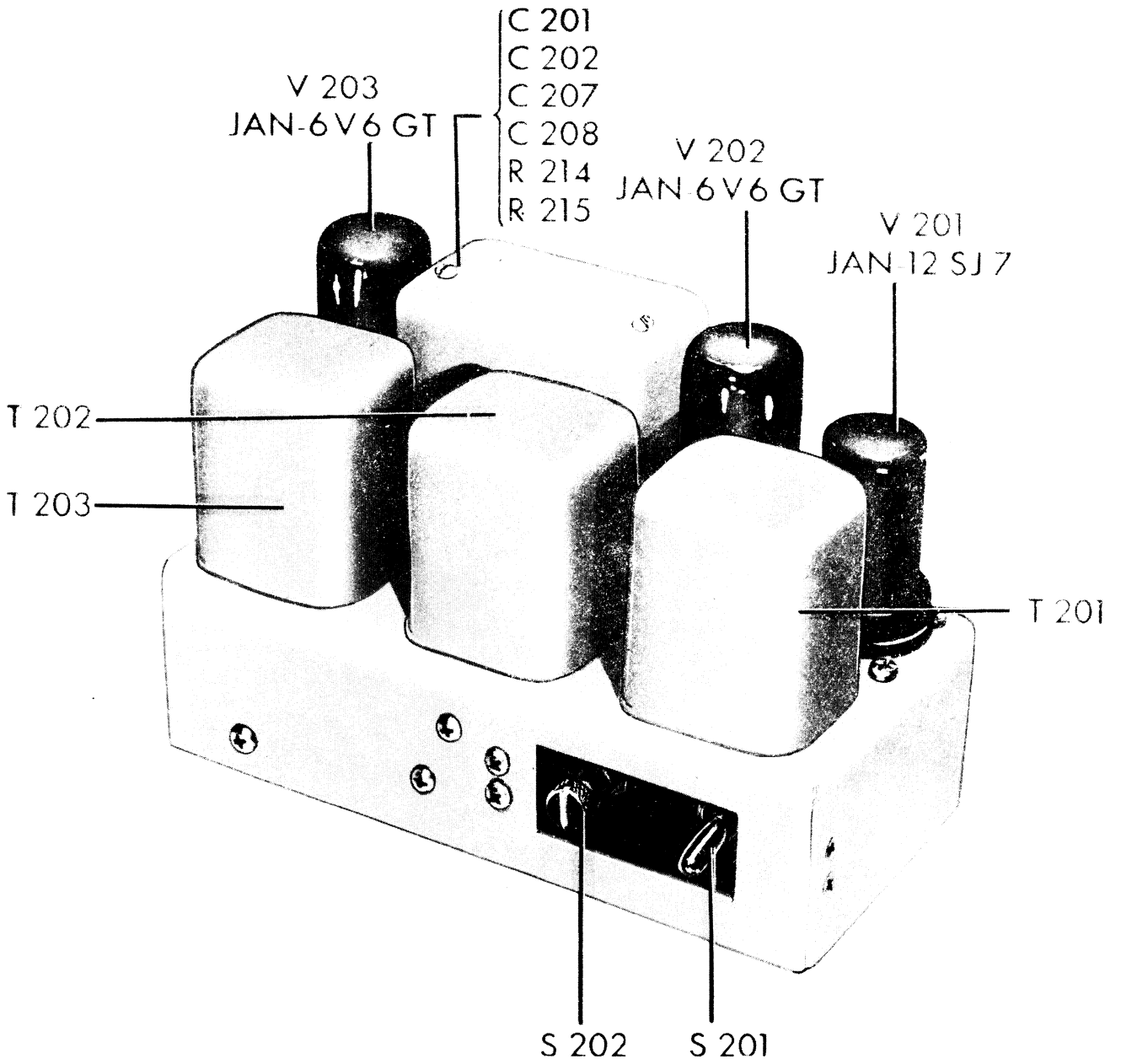

Figure 8-10. Audio Amplifier Unit — Top View

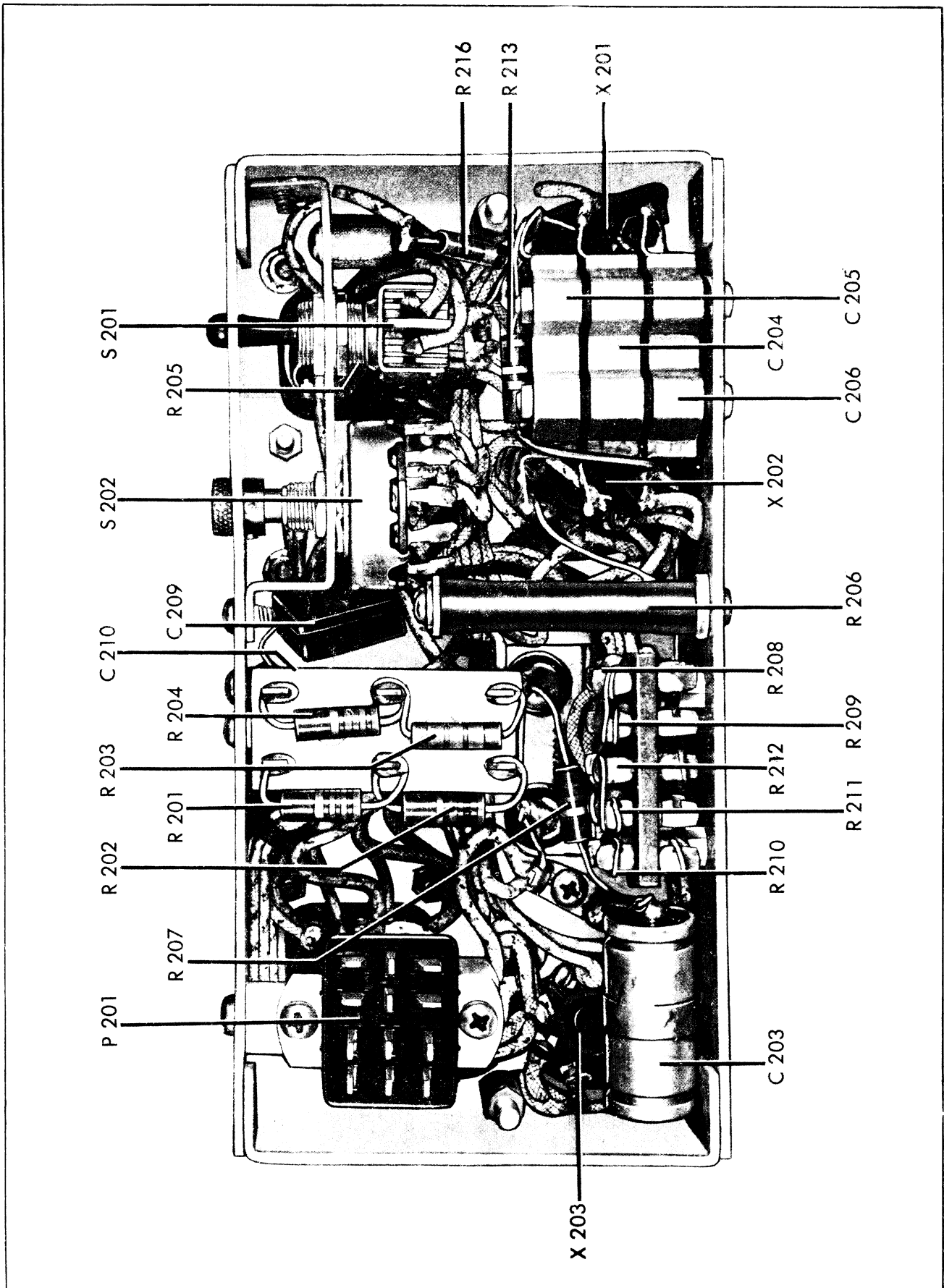

Figure 8-11. Audio Amplifier Unit — Bottom View

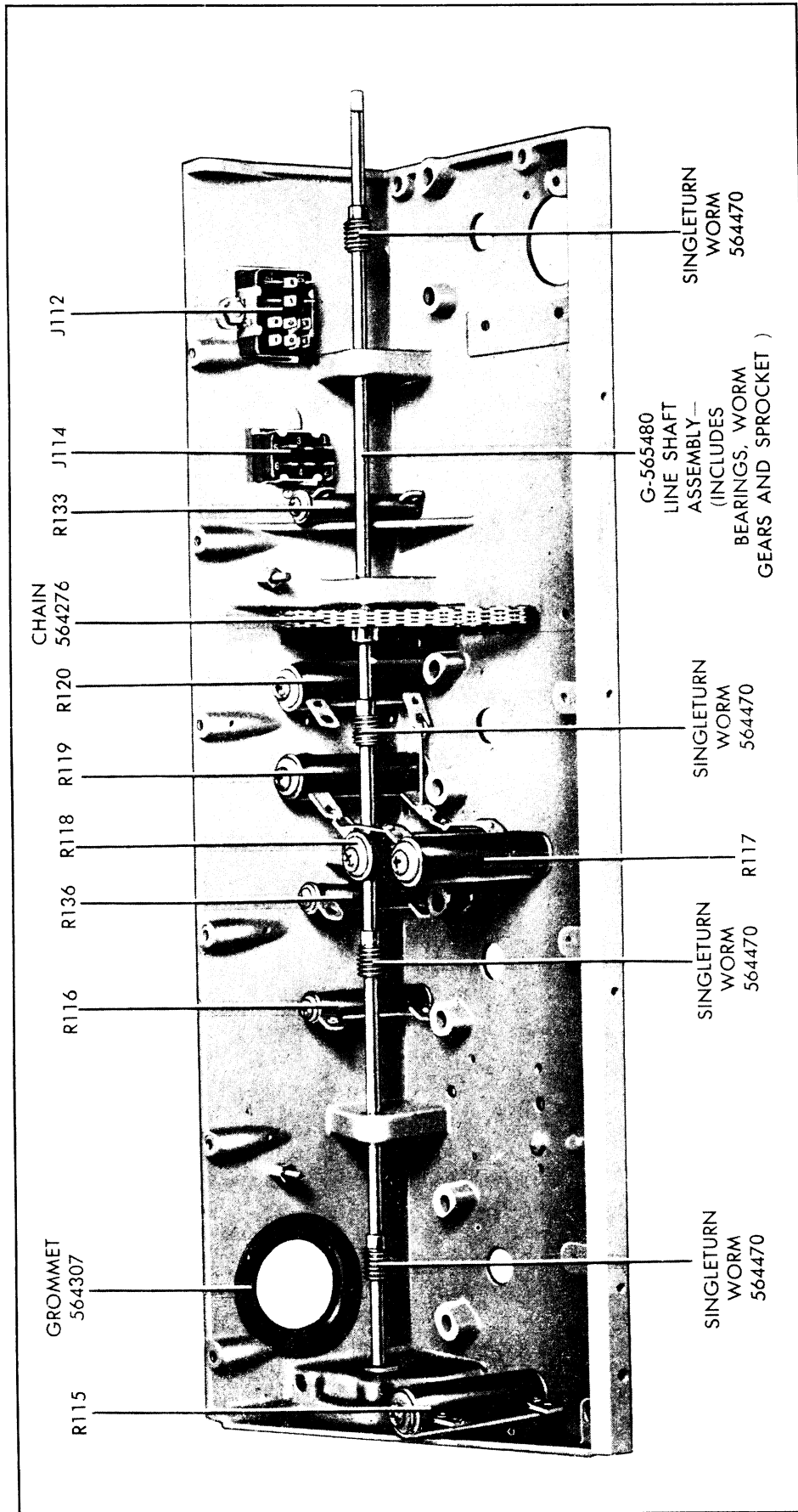

Figure 8-12. Autotune Casting

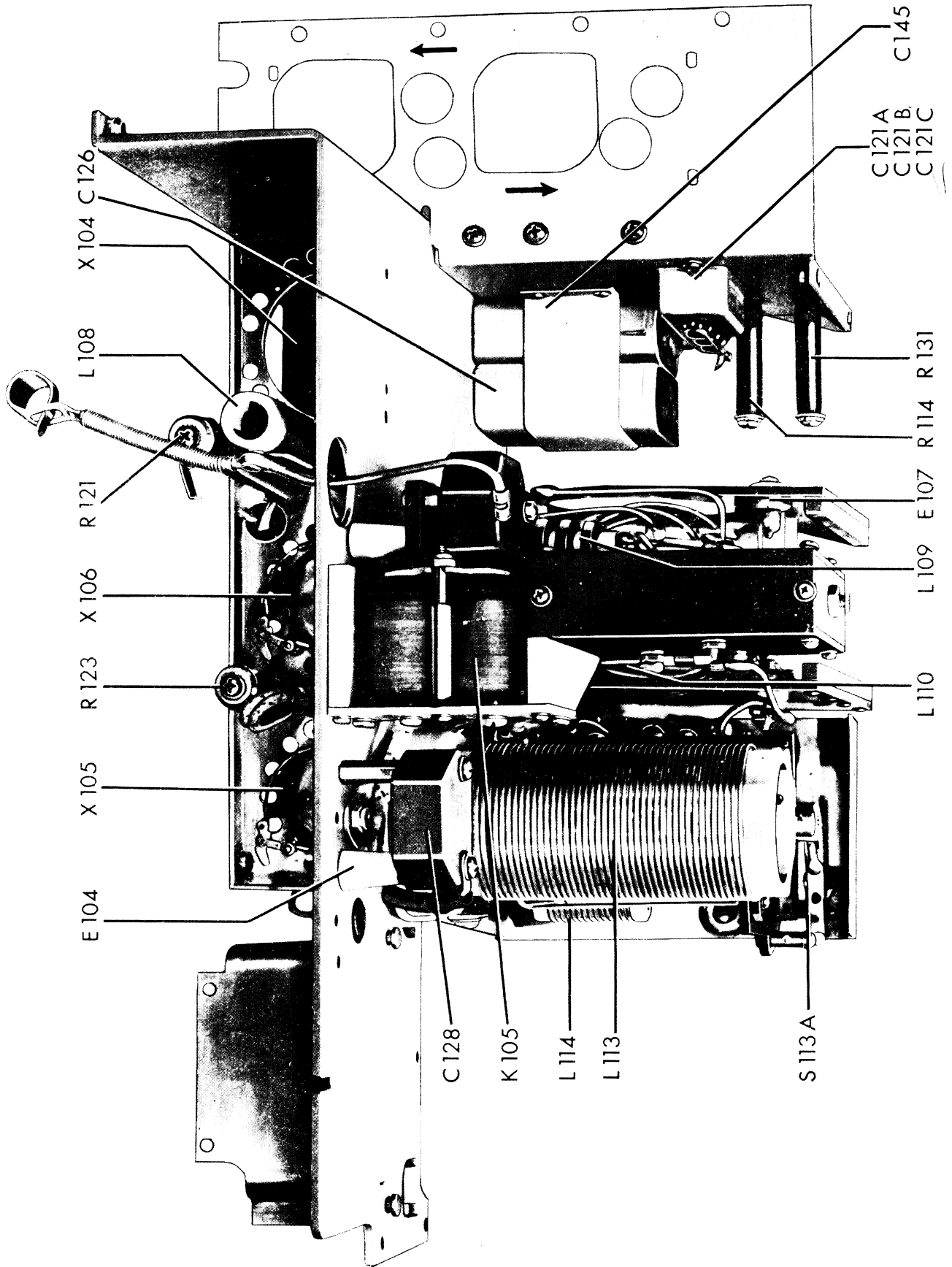

Figure 8-13. Firewall Assembly — Top View

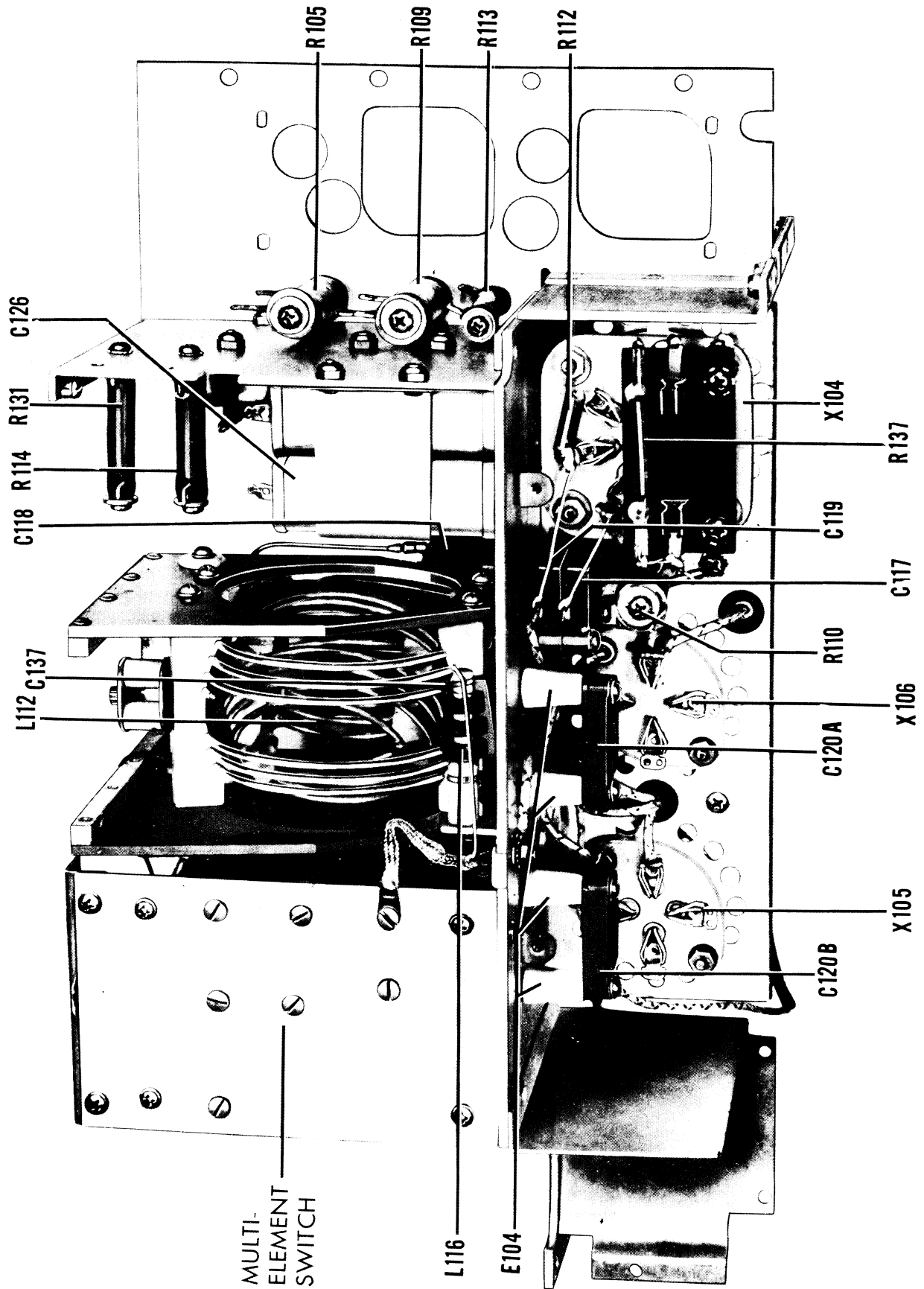

Figure 8-14. Firewall Assembly — Bottom View

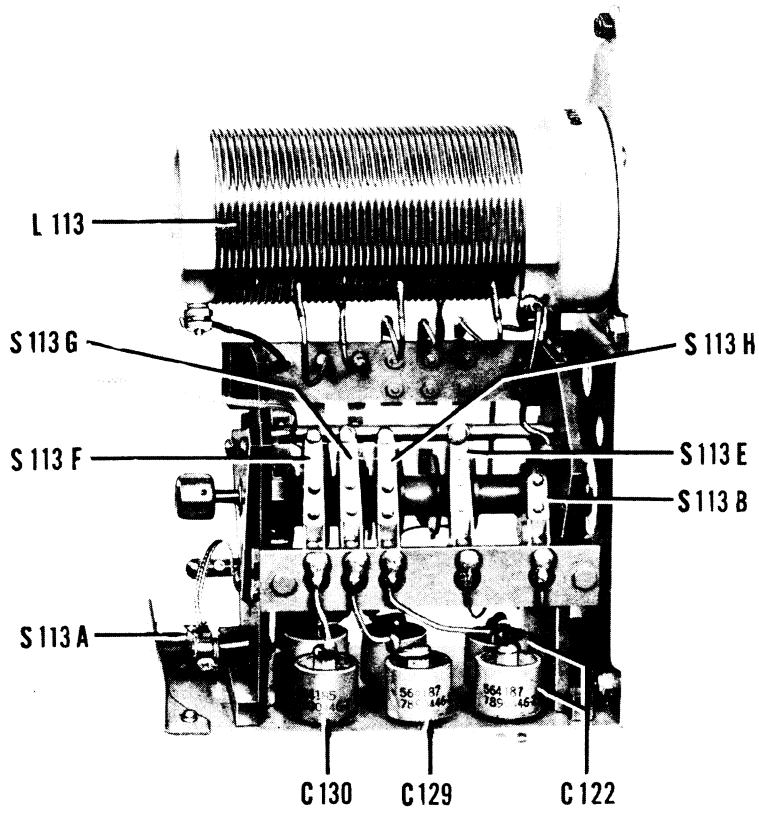
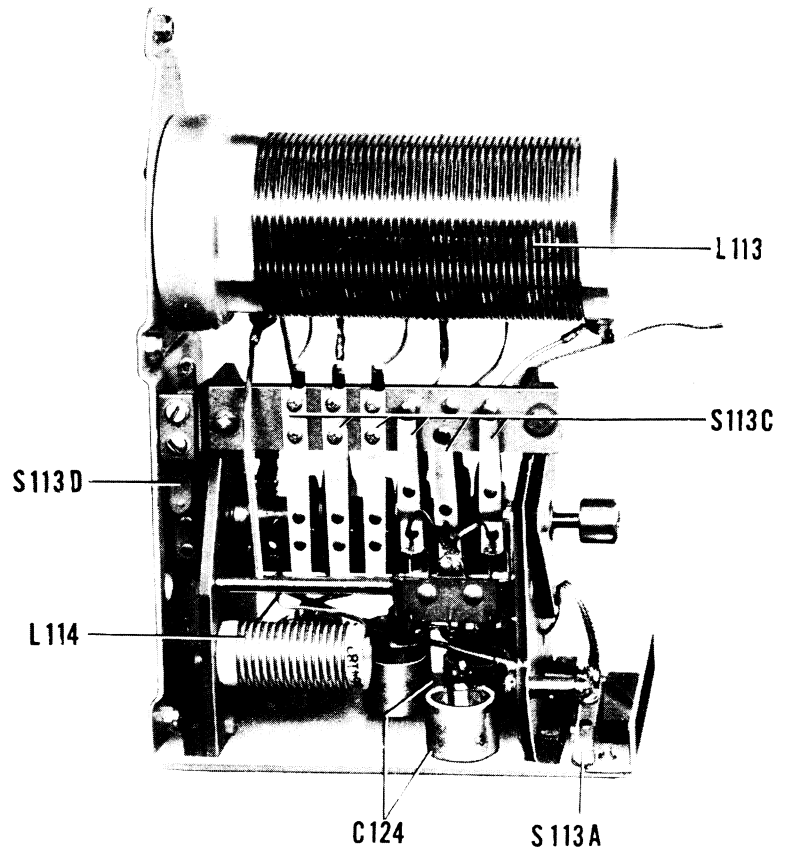

Figure 8-15. Multi-Element Switch — Right Side View

Figure 8-16. Multi-Element Switch — Left Side View



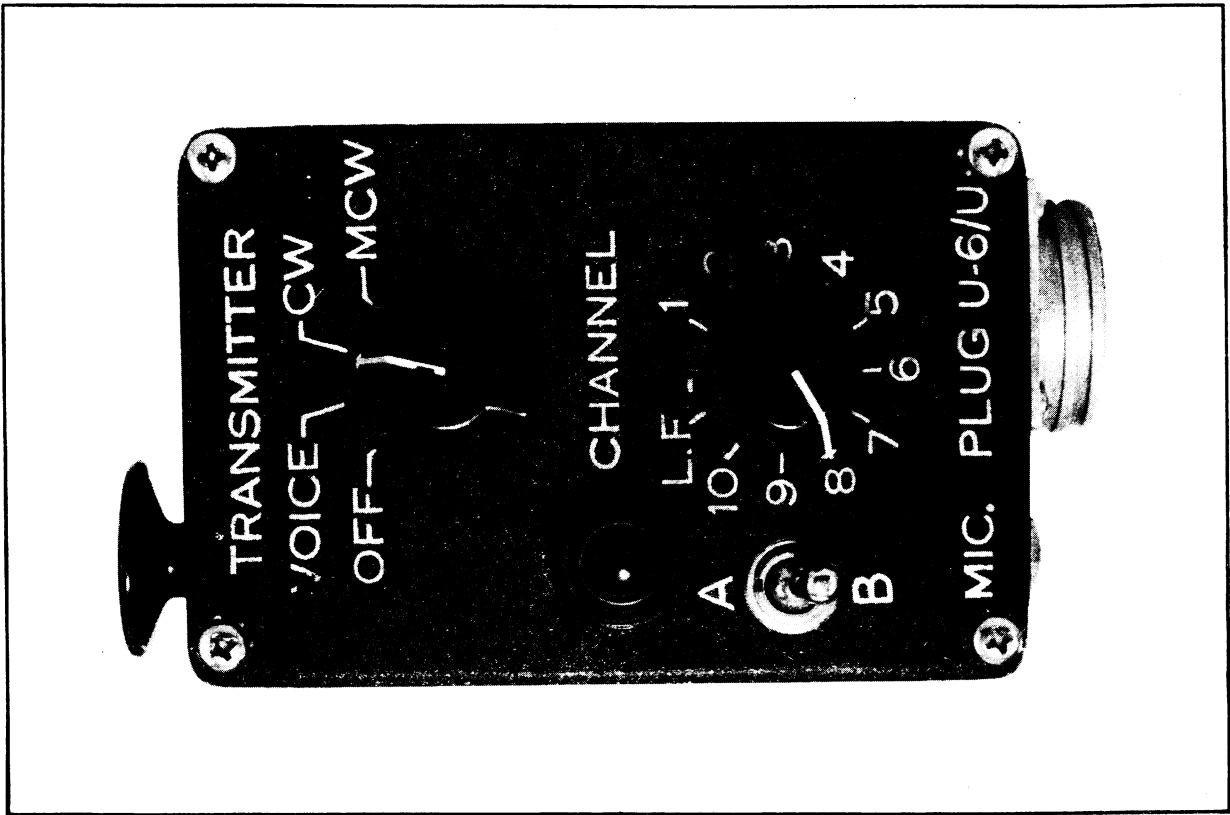

Figure 8-17 A.

Control Unit C-87 / ART-13 (Modified *) — Front View

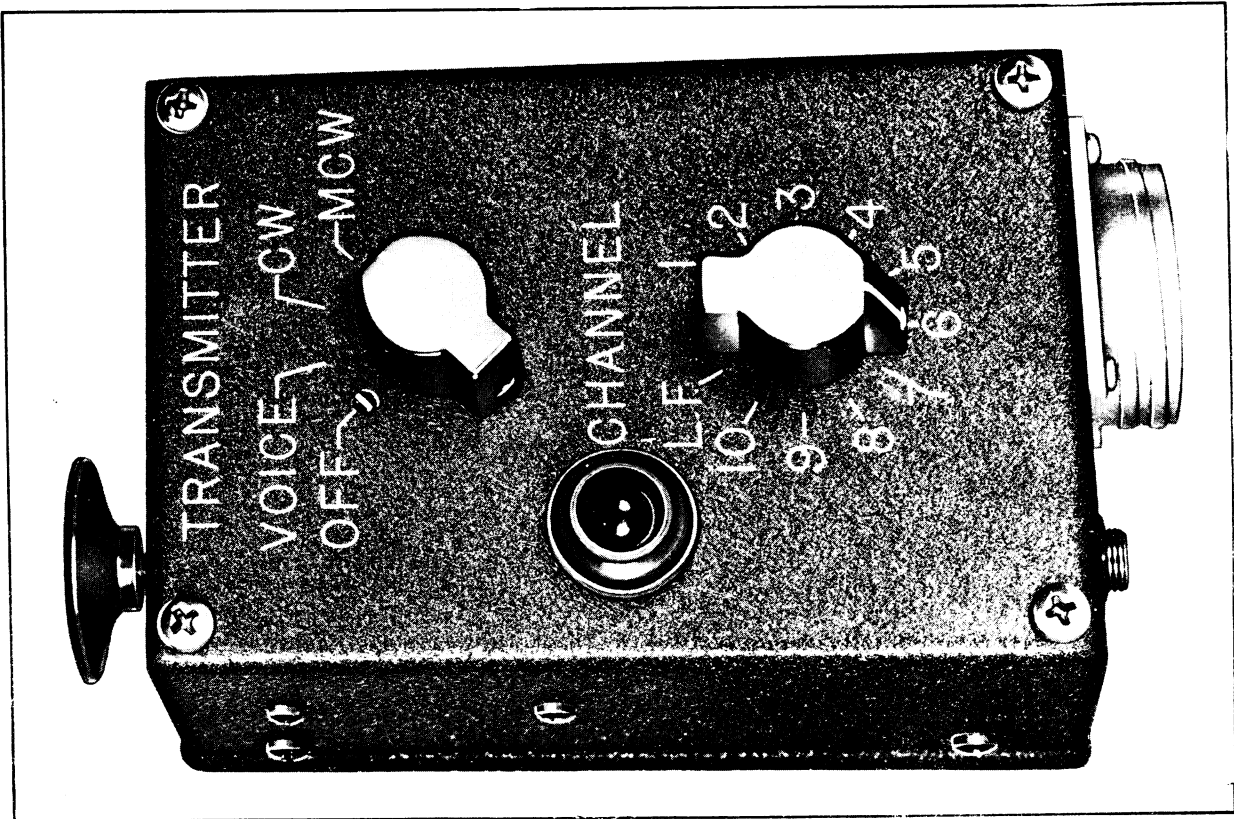

Figure 8-17. Control Unit C-87 / ART-13 — Front View

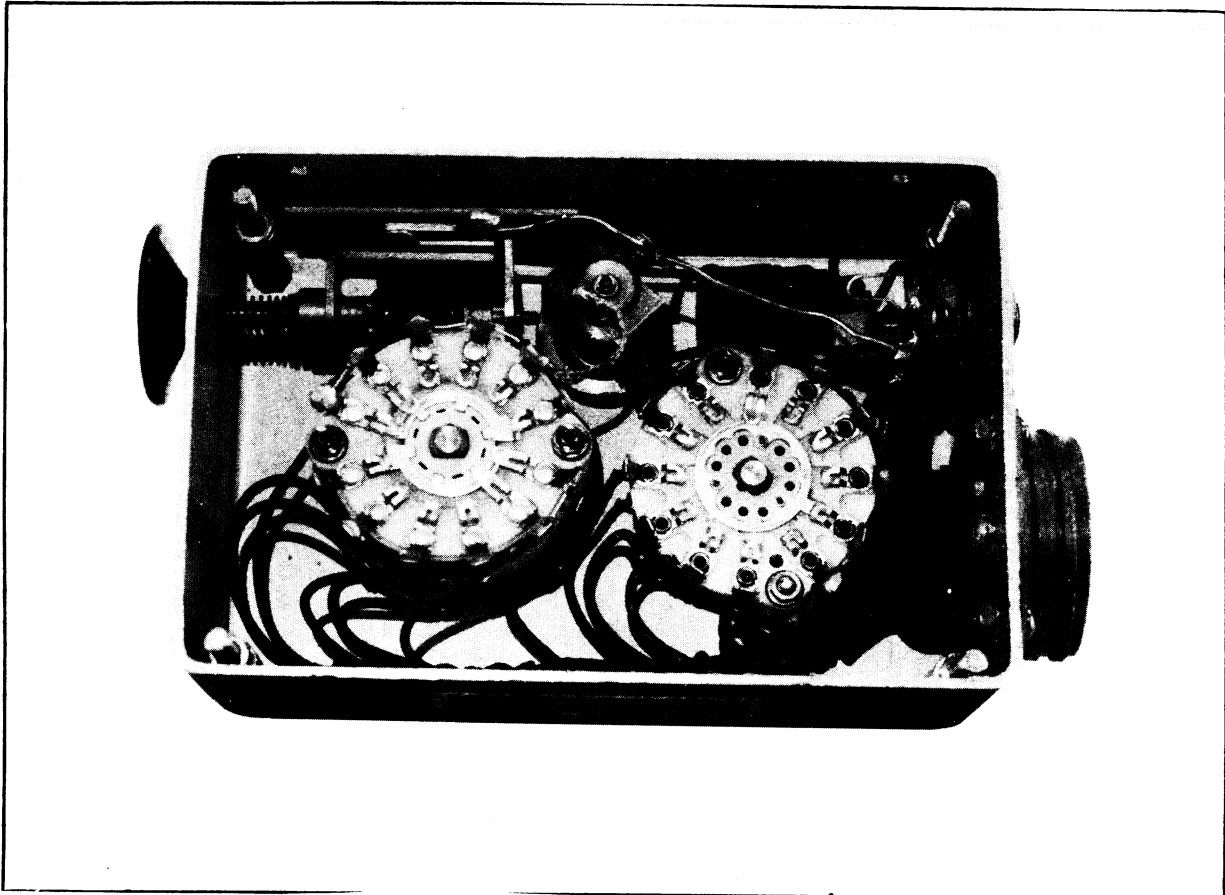

Figure 8-18A.
Control Unit C-87 / ART-13 (Modified *) — Rear View

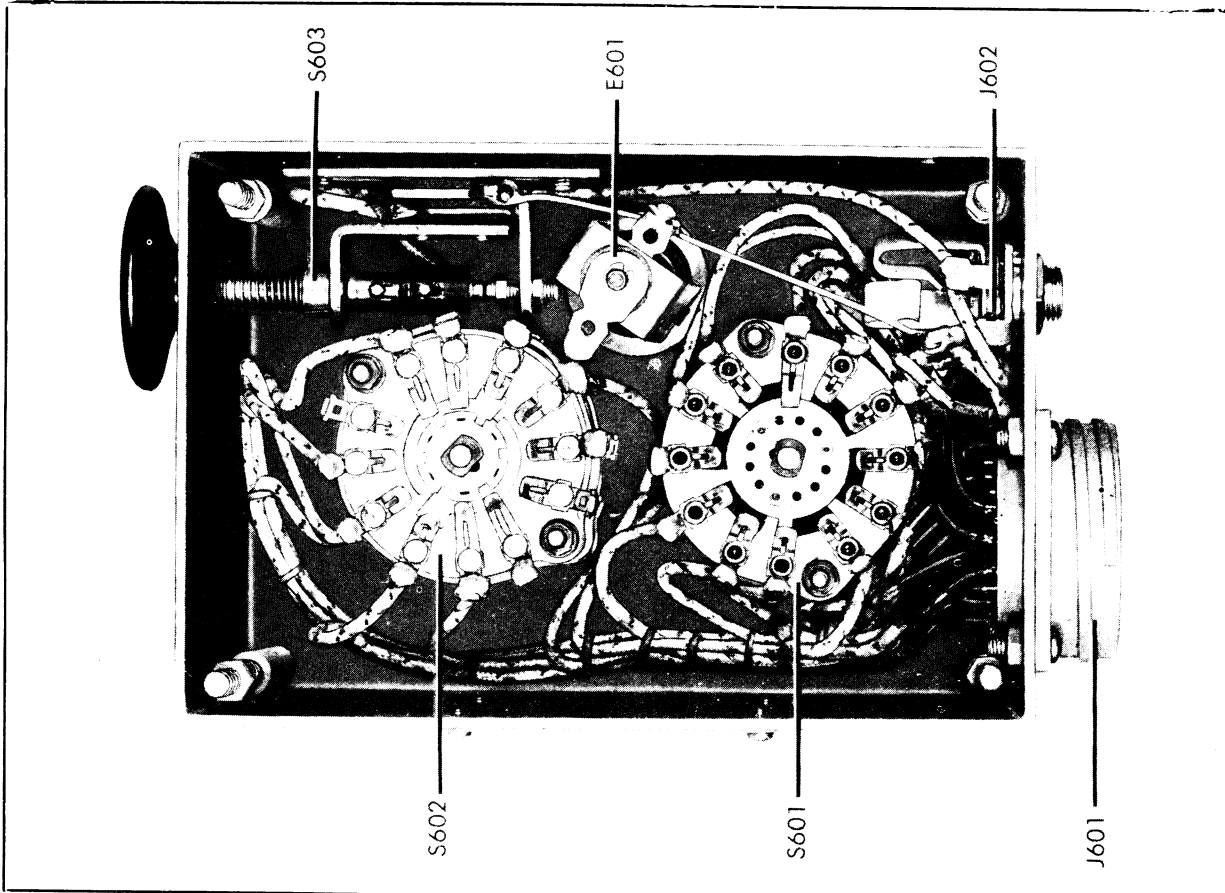

Figure 8-18. Control Unit C-87 / ART-13 — Rear View, Open

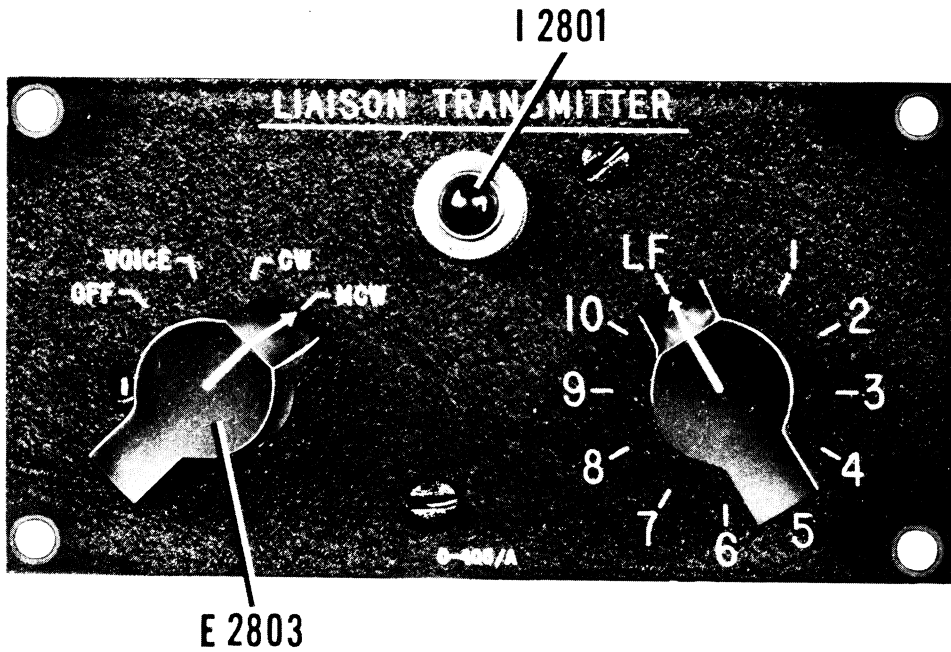

Figure 8-19. Control Panel C-405/A — Front View

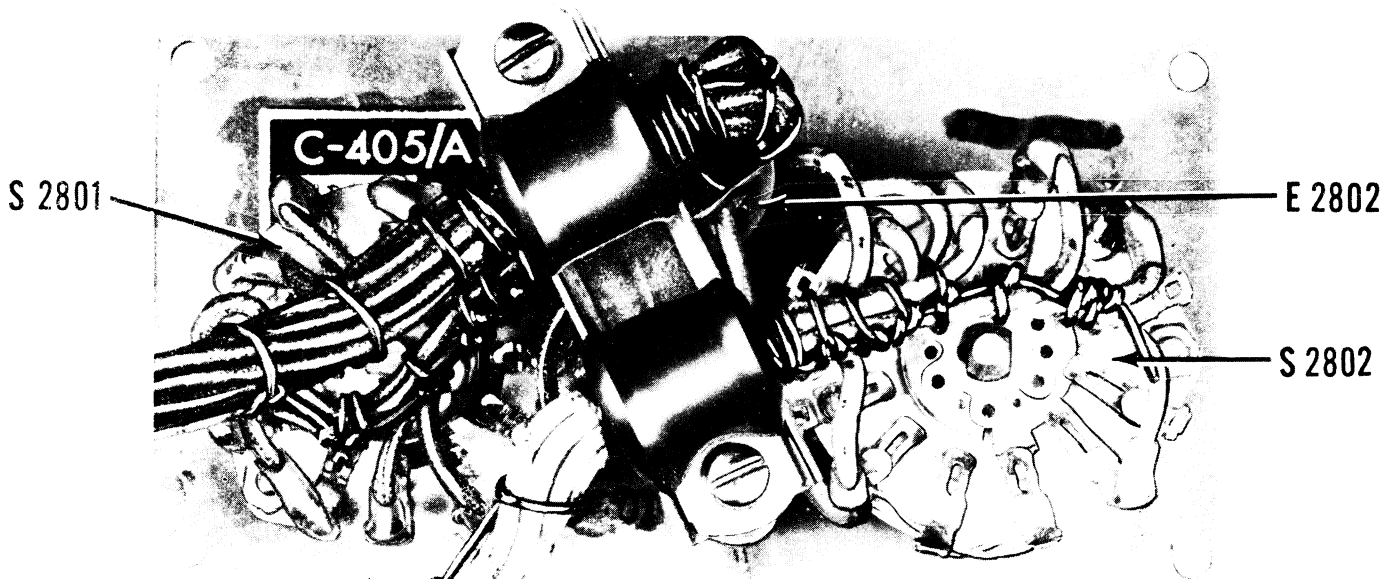

Figure 8-20. Control Panel C-405/A — Rear View, Open

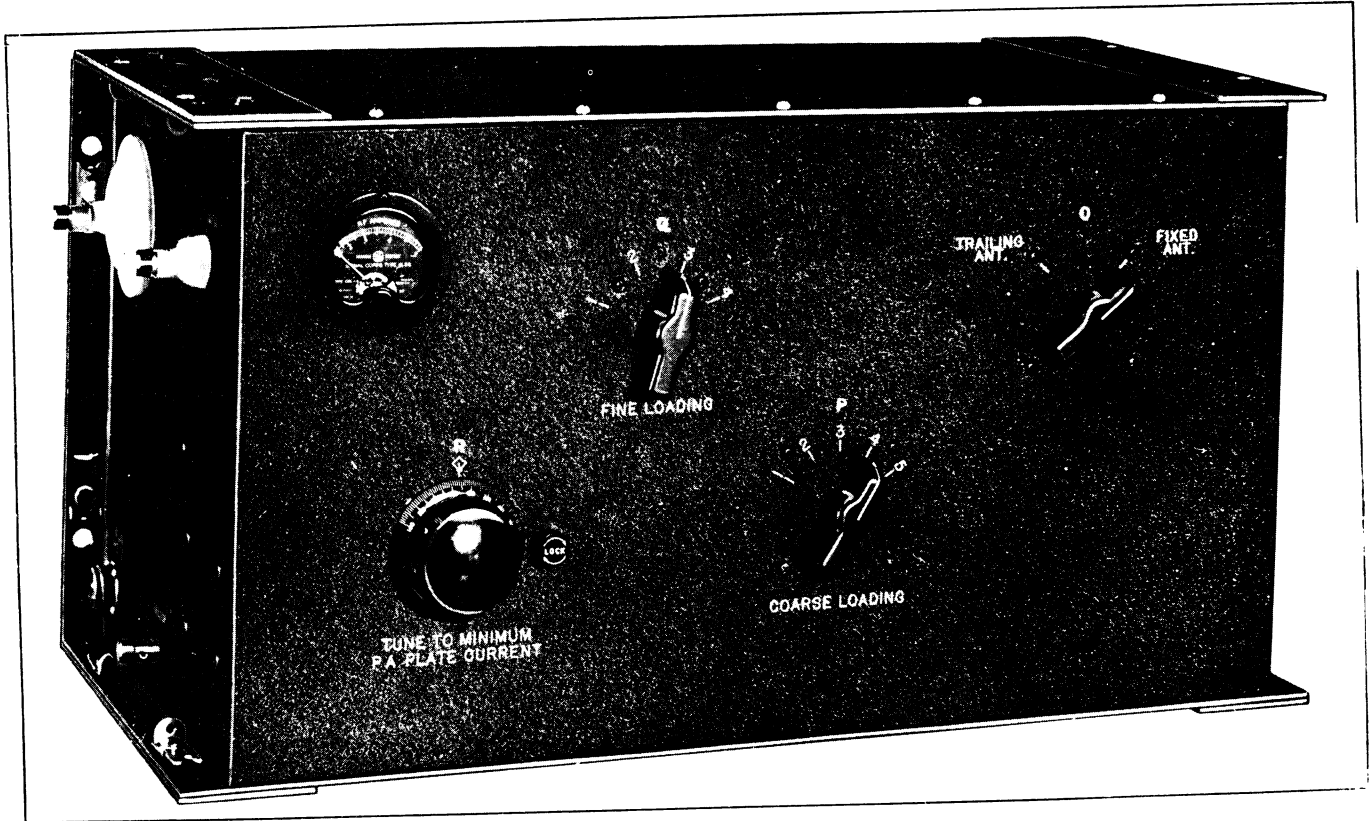

Figure 8-21. Antenna Loading Unit CU-32/ART-13A — Front View

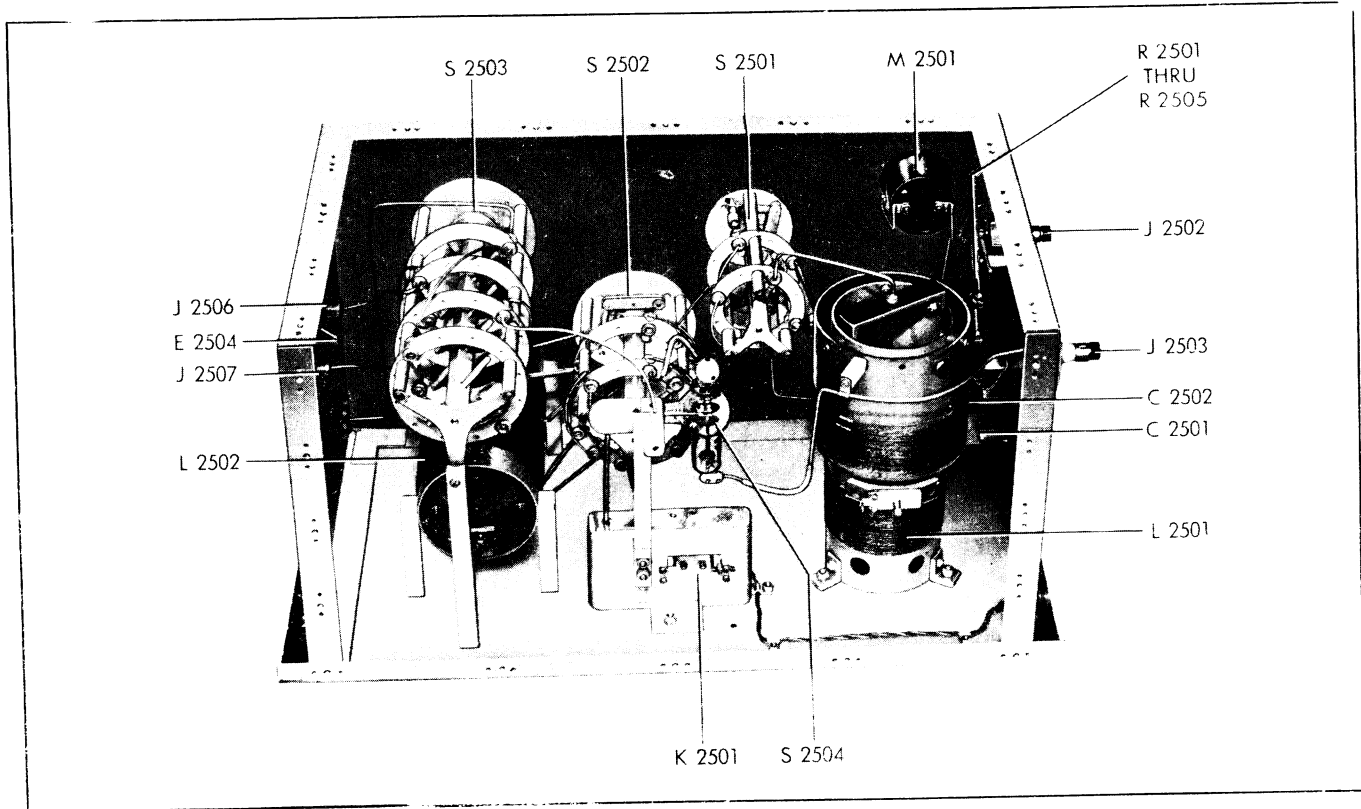

Figure 8-22. Antenna Loading Unit CU-32/ART-13A — Rear View, Open

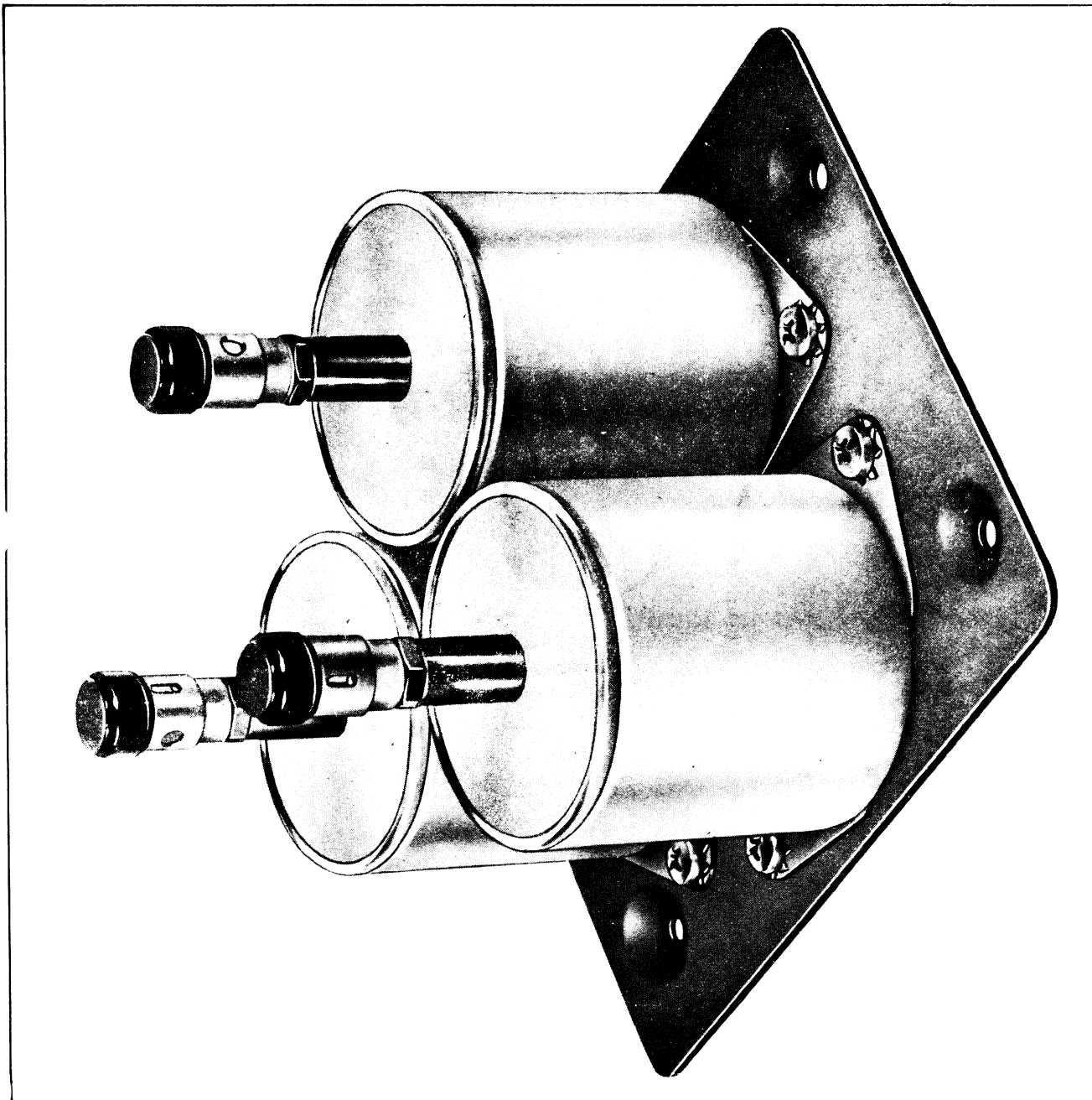

Figure 8-23. Antenna Shunt Capacitor CU-24/ART-13

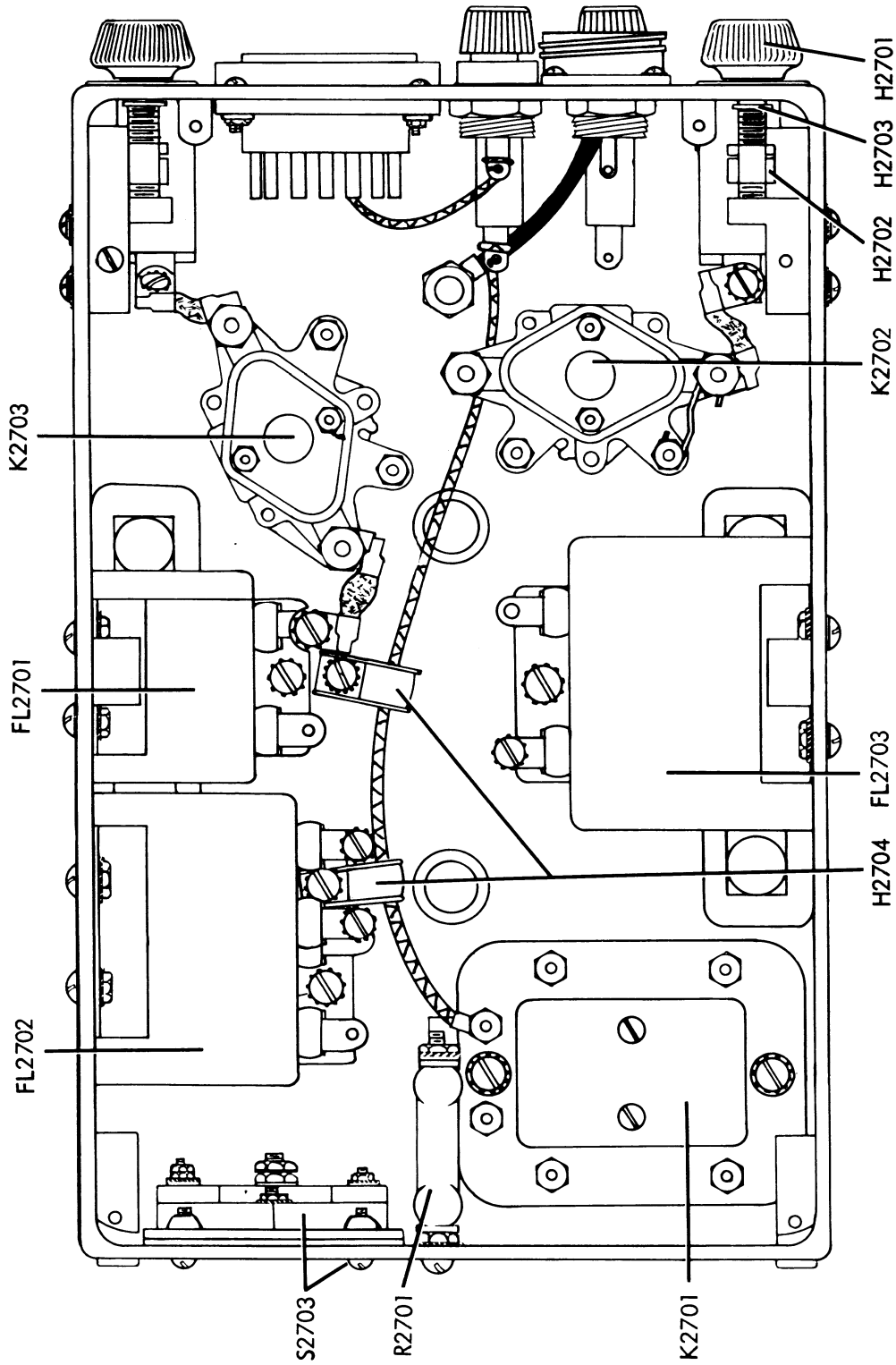

Figure 8-23A. Eicor Dynamotor DY-17A/ART-13A—Bottom View

)

,

,

)

)

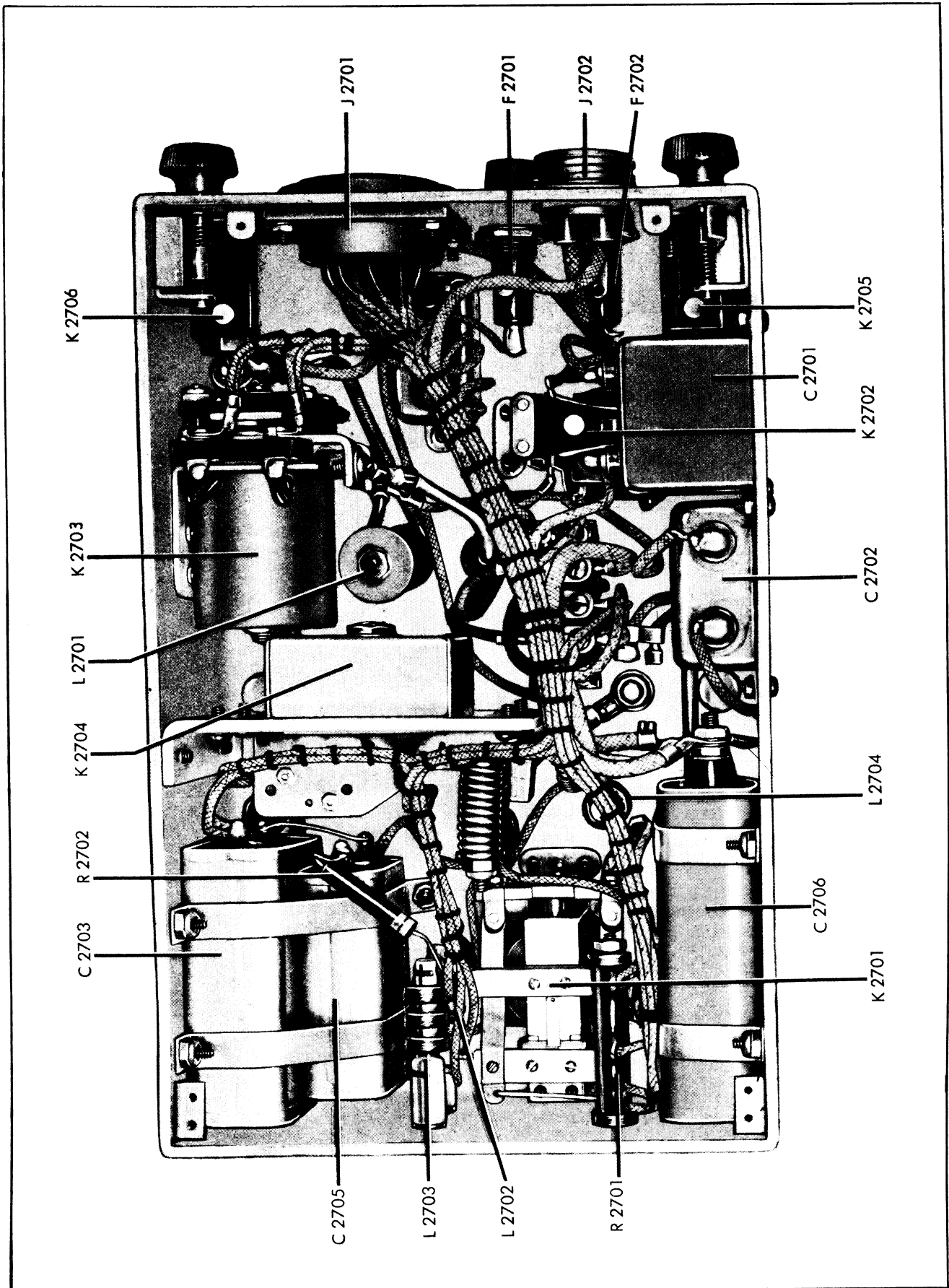

Figure 8-24. Dynamometer Unit DY-17/ART-13A — Bottom View

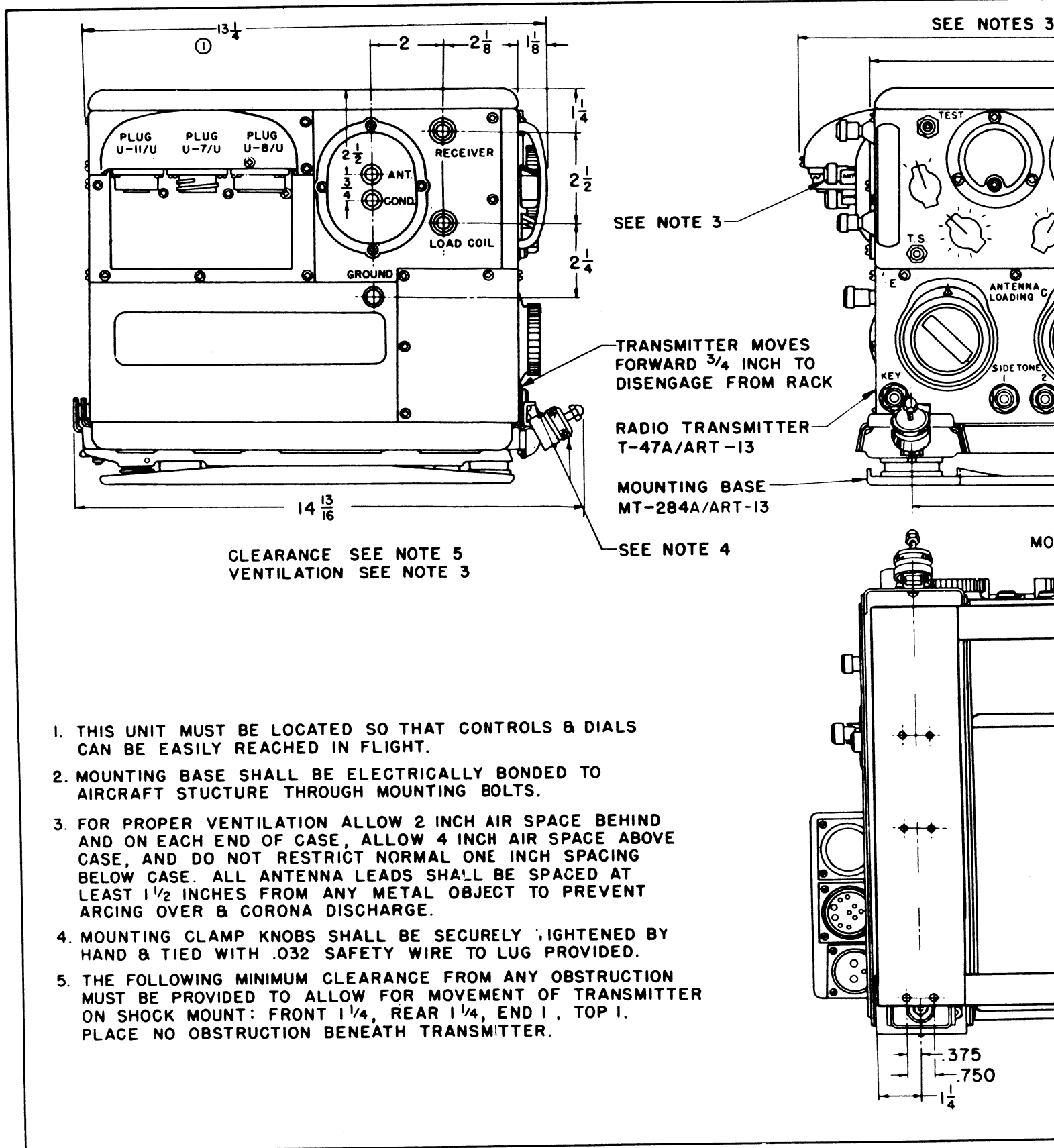
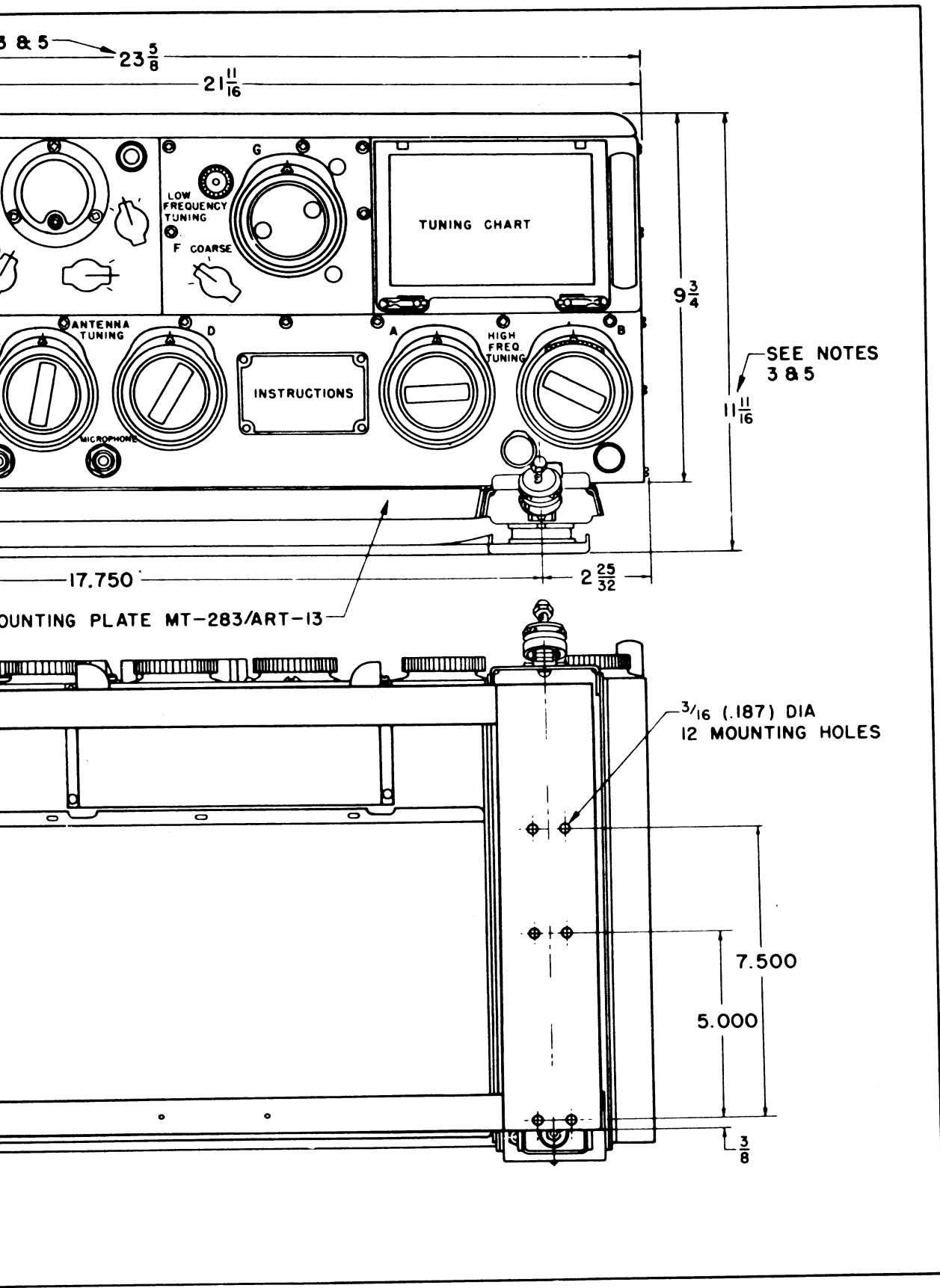

Figure 8-25. Radio Transmitter T-47A/ART-13 and Mounting Base MT-284A/ART-13—Outline Dimensions



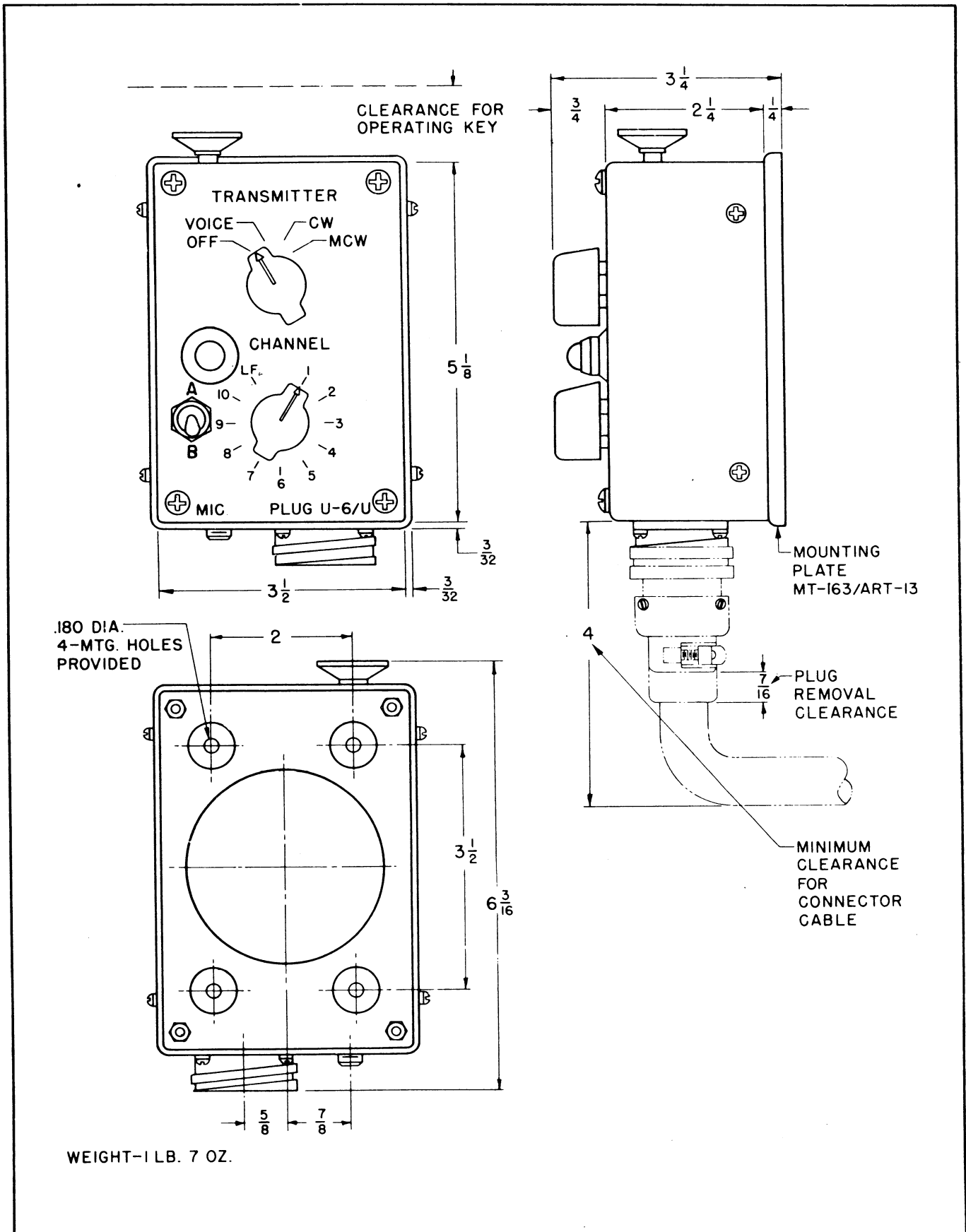

Figure 8-26. Control Unit C-87/ART-13 (Modified *) — Outline Dimensions

*Applies only to AN/ART-13B

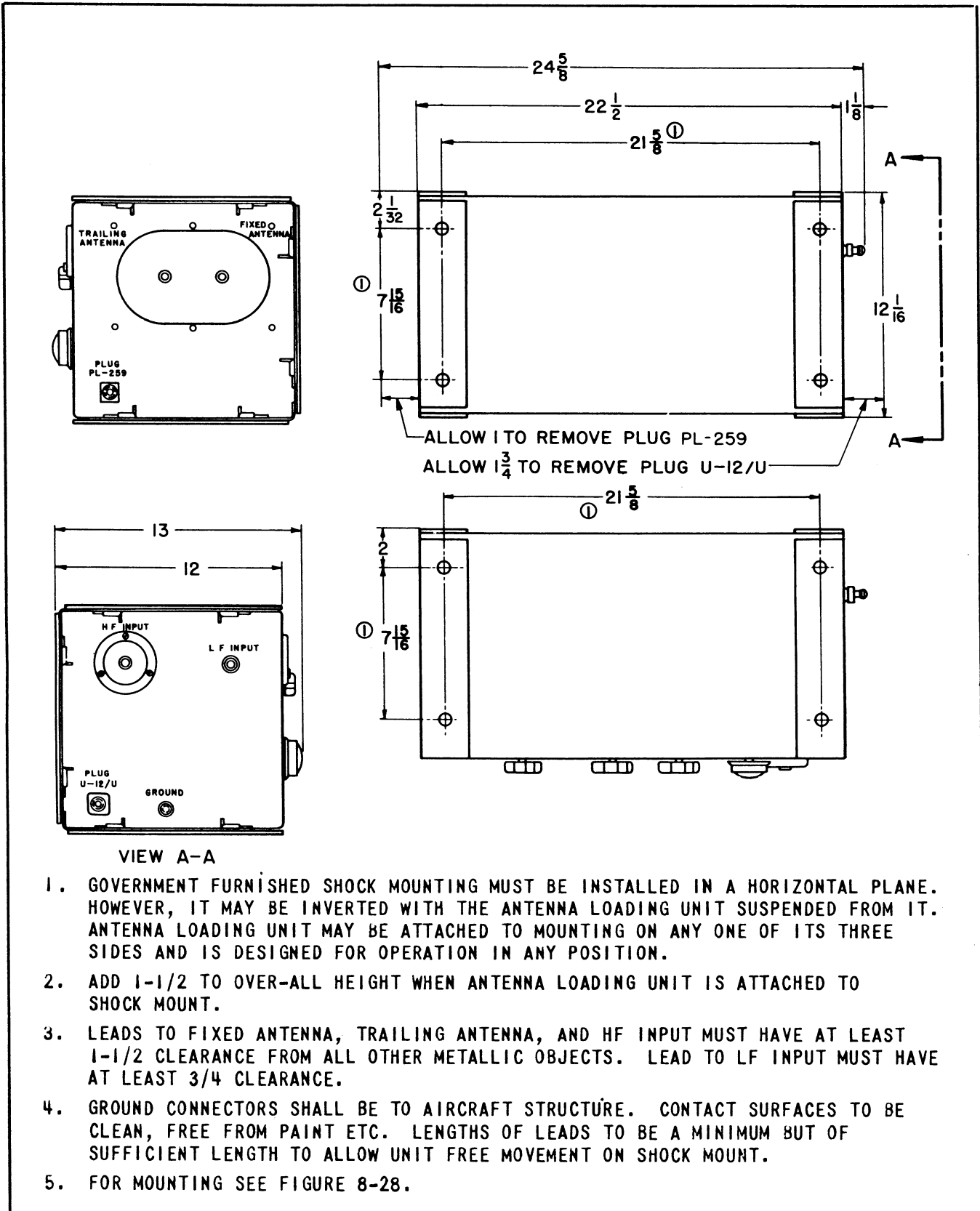

Figure 8-27. Antenna Loading Unit CU-32/ART-13A — Outline Dimensions

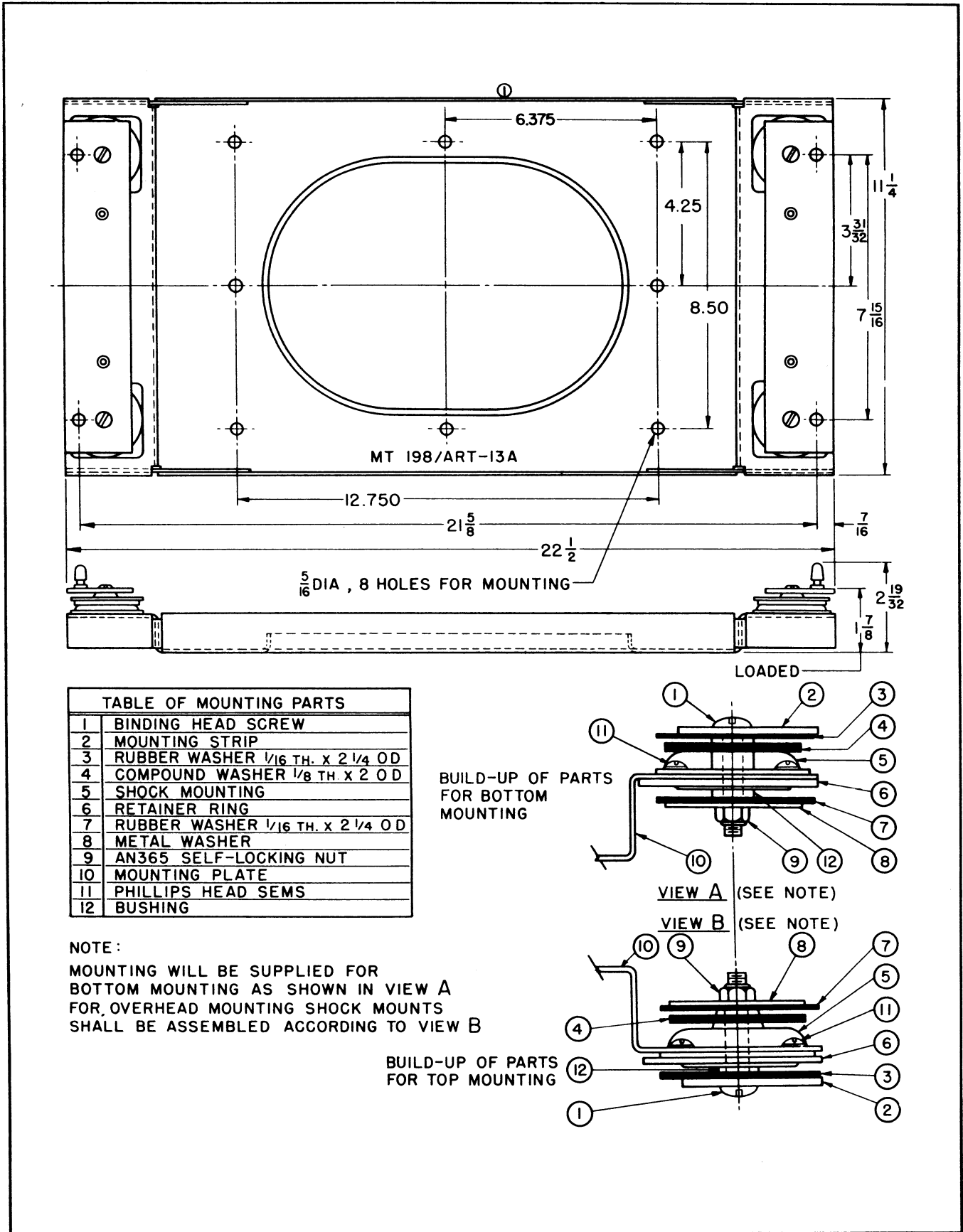
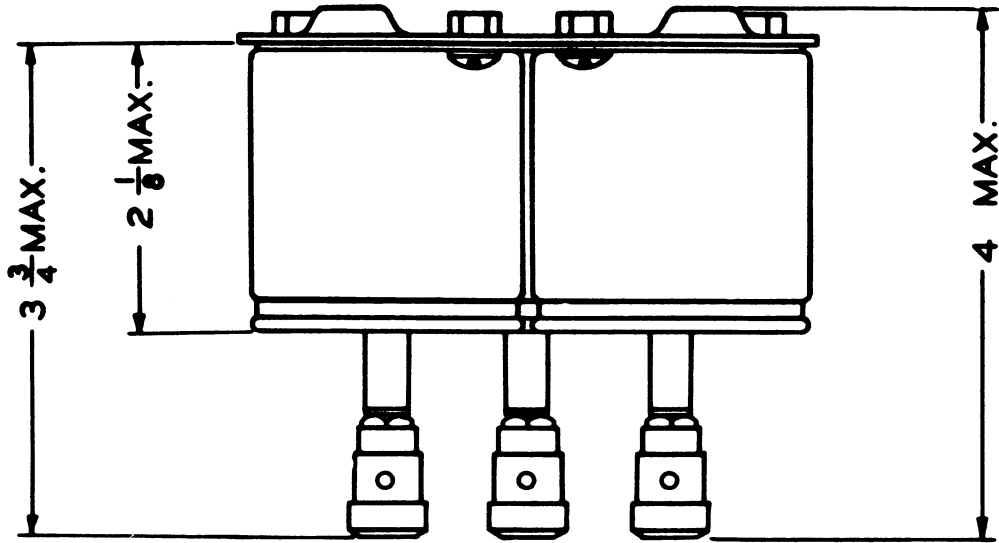
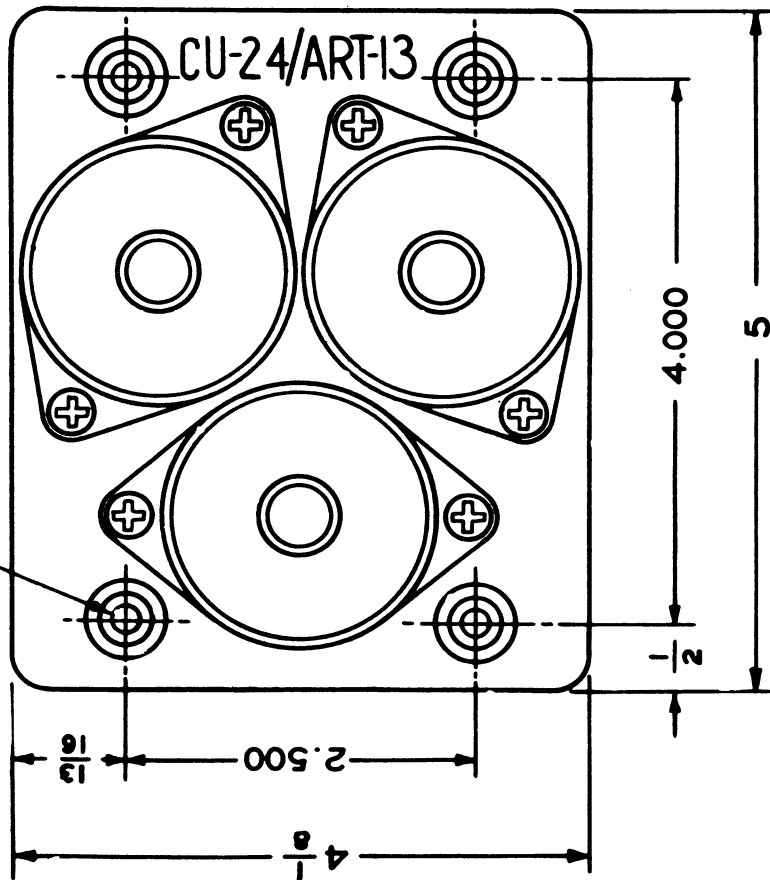

Figure 8-28. Mounting Base MT-198/ART-13A — Outline Dimensions

ANTENNA SHUNT CAPACITOR CU-24/ART-13
WEIGHT: 1.75 POUNDS MAX.

4 HOLES .178 ± .002 DIAM.



NOTE:
BASE MUST BE ELECTRICALLY BONDED TO
AIRCRAFT STRUCTURE THROUGH MOUNTING
FEET AND SCREWS.

Figure 8-29. Antenna Shunt Capacitor CU-24/ART-13 — Outline Dimensions

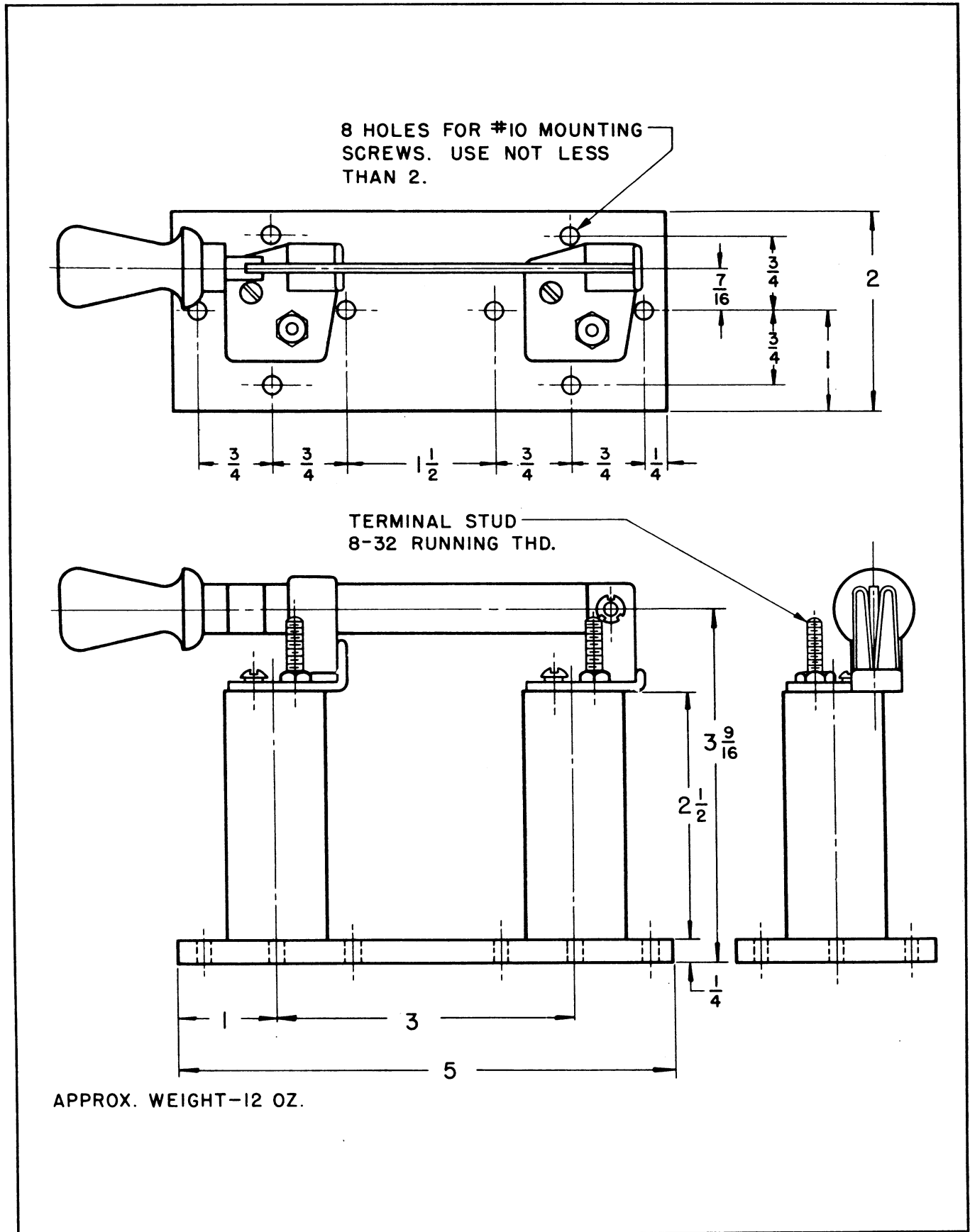

Figure 8-30. Switch SA-46/ART-13 — Outline Dimensions

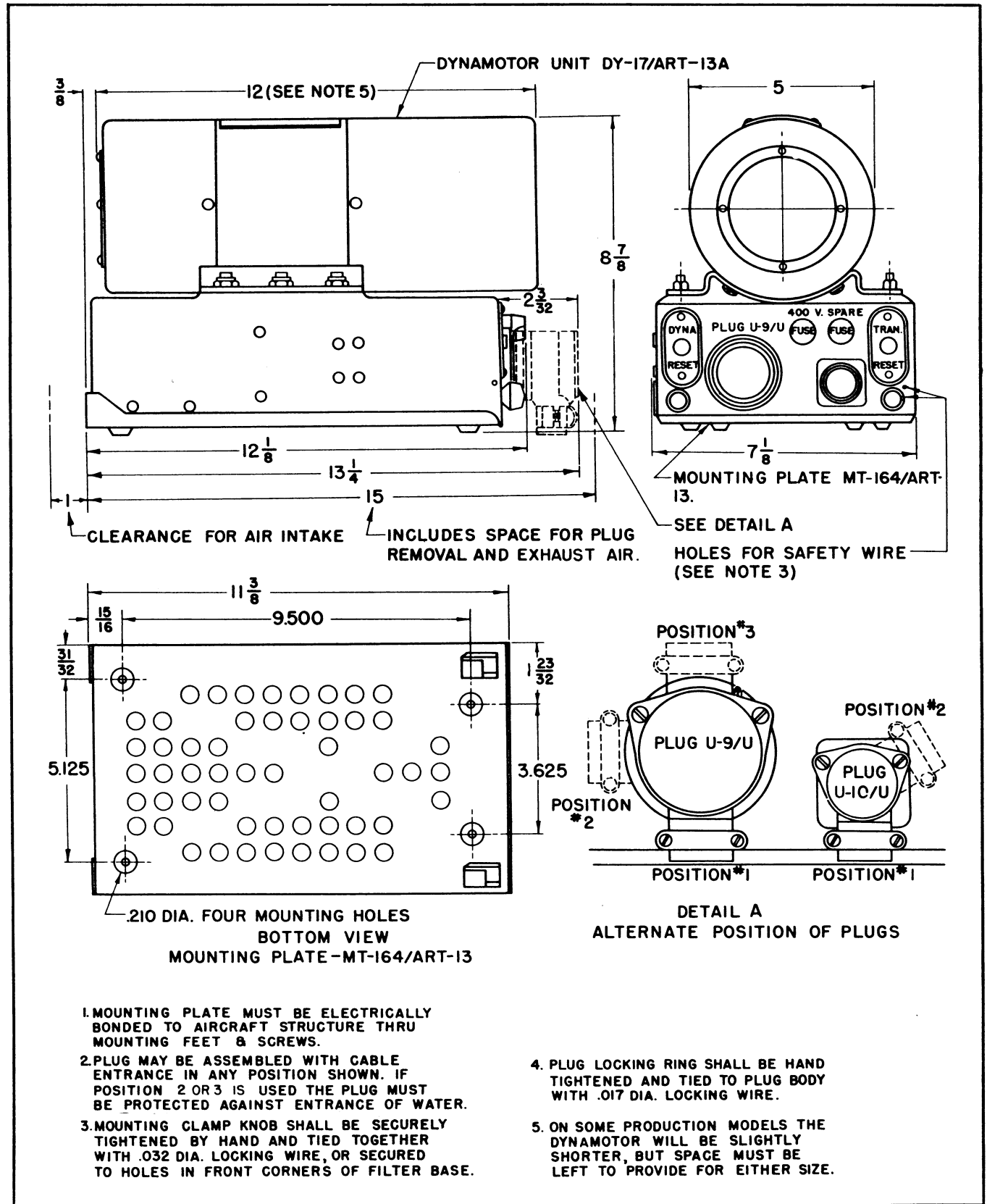

Figure 8-31. Dynamotor Unit DY-17/ART-13A — Outline Dimensions

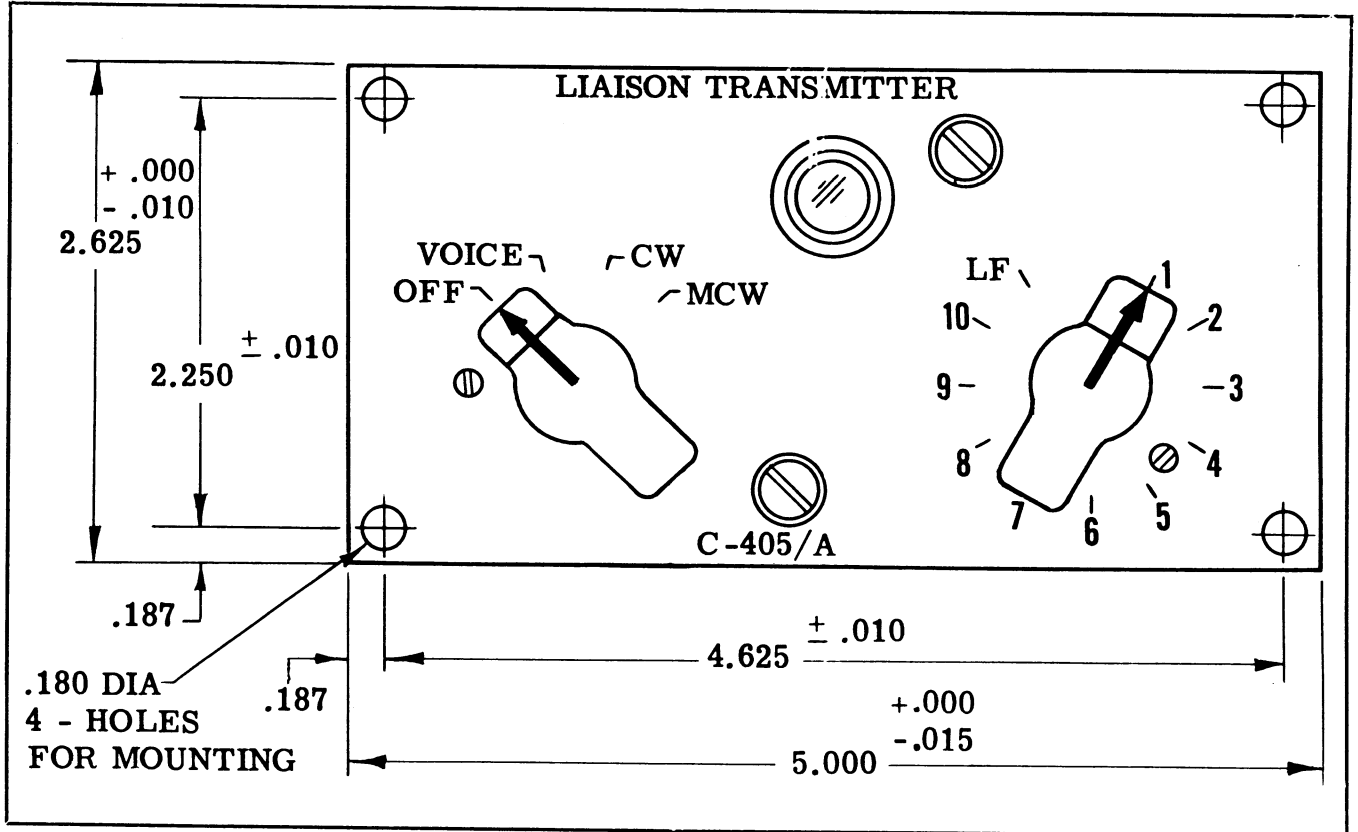

Figure 8-32. Control Panel C-405/A — Outline Dimensions

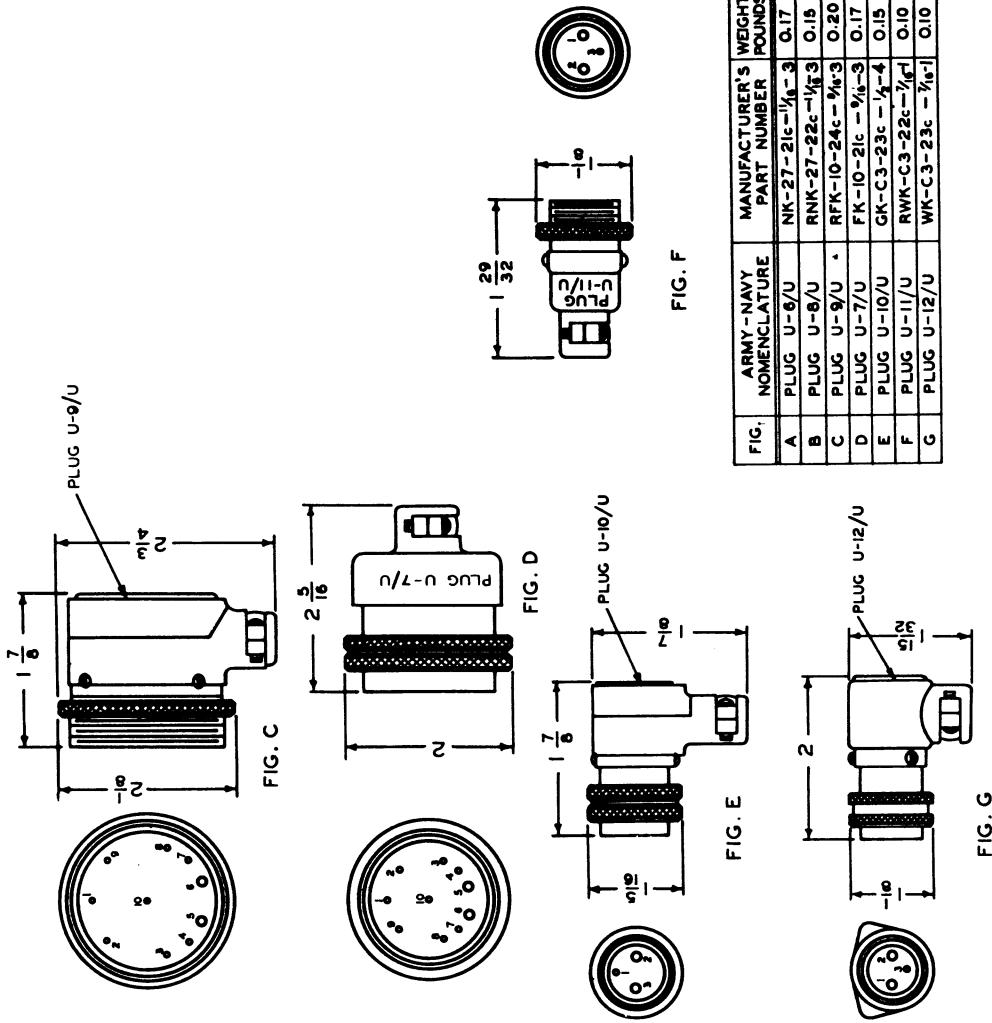

FIG.	ARMY-NAVY NOMENCLATURE	MANUFACTURER'S PART NUMBER	WEIGHT POUNDS
A	PLUG U-6/U	NK-27-21c-1/8-3	0.17
B	PLUG U-9/U	RNK-27-22c-1/8-3	0.15
C	PLUG U-8/U	RFK-10-24c-1/8-3	0.20
D	PLUG U-7/U	FK-10-21c-1/8-4	0.17
E	PLUG U-10/U	GK-C3-23c-1/4-4	0.15
F	PLUG U-11/U	RWK-C3-22c-1/4-1	0.10
G	PLUG U-12/U	WK-C3-23c-1/8-1	0.10

- NOTES:
- 1- REMOVE INSULATION FROM $\frac{1}{4}$ INCH OF END OF EACH WIRE AND TIN.
 - 2- REMOVE PLUG COVER, LOOSEN CABLE CLAMP, AND PASS WIRES THROUGH PLUG COVER.
 - 3- SLIP A PIECE OF PHENOLIC TUBING OVER EACH WIRE. THIS TUBING SHOULD BE LONG ENOUGH TO COVER THE SOLDERED CONNECTION AND EXTEND THROUGH THE CABLE CLAMP.
 - 4- SOLDER EACH WIRE TO ITS APPROPRIATE PIN. DO NOT USE EXCESSIVE AMOUNTS OF SOLDER AND WATCH FOR STRAY STRANDS WHICH MAY SHORT PINS TOGETHER. SLIDE TUBING DOWN OVER EACH SOLDERED CONNECTION.
 - 5- DRAW THE PLUG COVER OVER THE CABLE AND THE ENDS OF THE PHENOLIC TUBING. REASSEMBLE PLUG AND TIGHTEN CABLE CLAMP.
 - 6- THE RIGHT ANGLE PLUG COVERS MAY BE ASSEMBLED TO THE PLUG BODY IN OTHER POSITIONS THAN THOSE SHOWN, TO SUIT INSTALLATION.

Figure 8-33. Plugs for Radio Transmitting Set AN/ART-13A

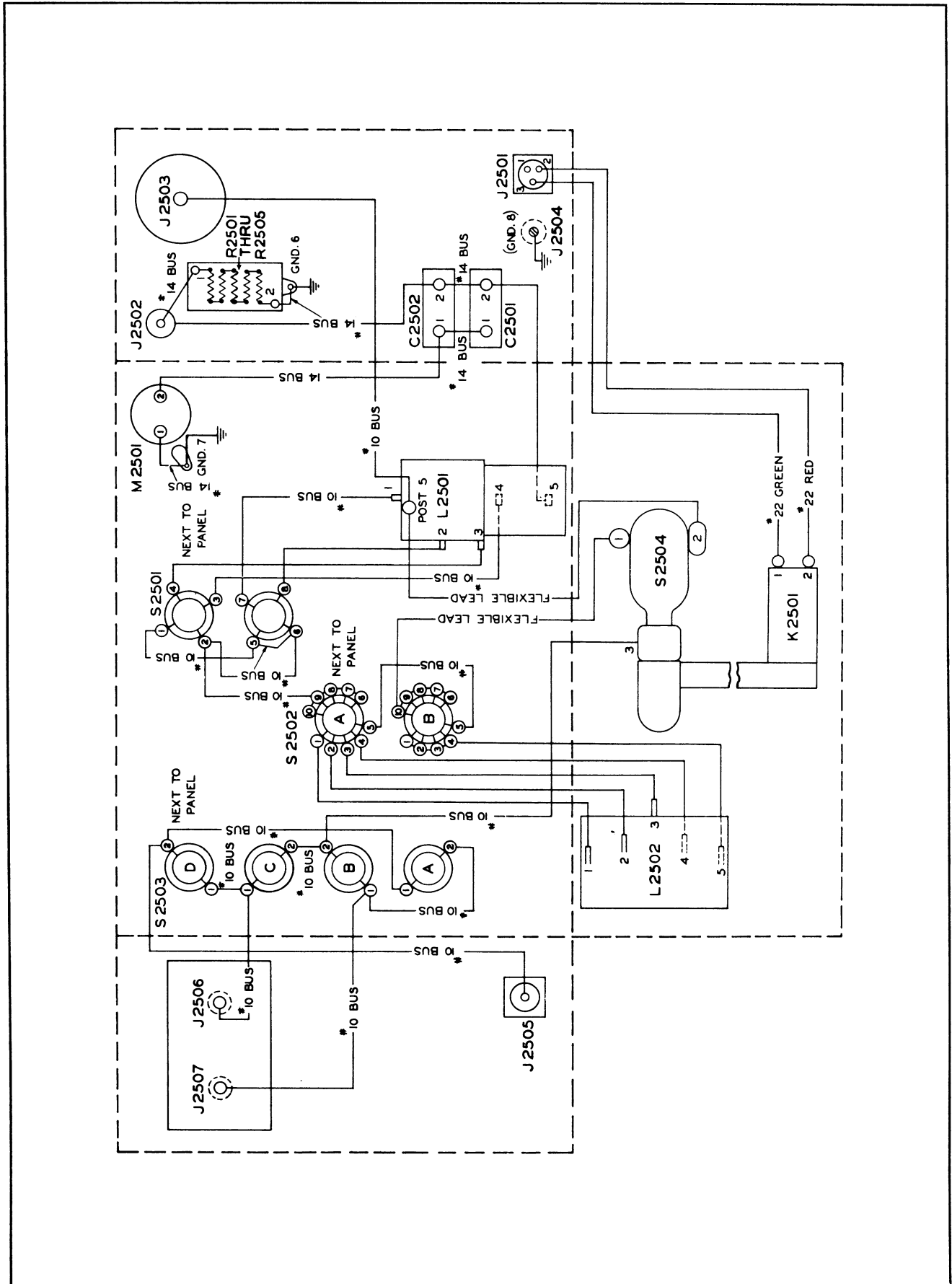

Figure 8-34. Antenna Loading Unit CU-32/ART-13A — Practical Wiring Diagram

NOTE:
 WIRE INSULATION RATING (FUNGUS RESISTANT)
 #22 WIRE: A.W.G. STRANDED, THERMOPLASTIC
 INSULATION - 600 VOLTS.

COLOR ABBREVIATIONS
 BLK - BLACK
 WH - WHITE

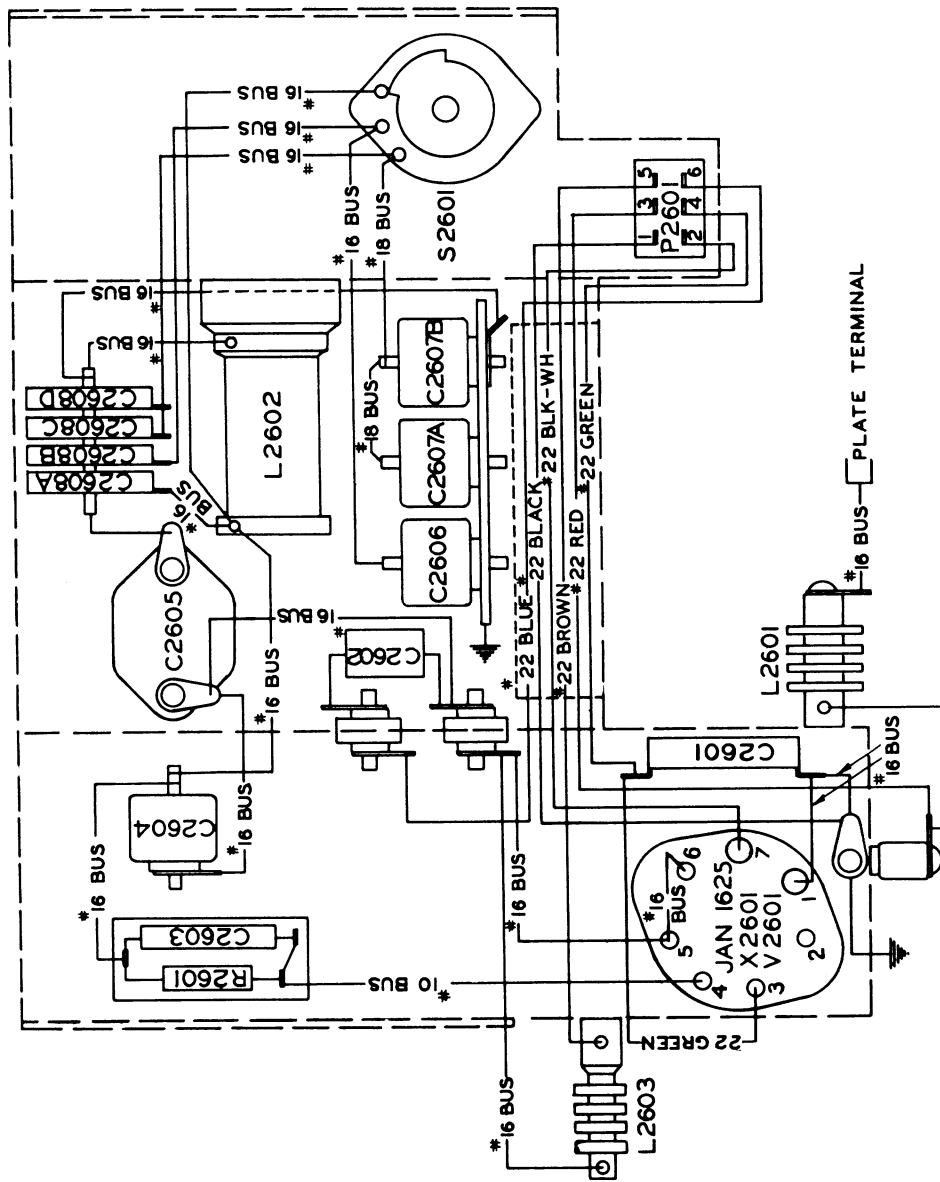

Figure 8-35. Low Frequency Oscillator Unit — Practical Wiring Diagram

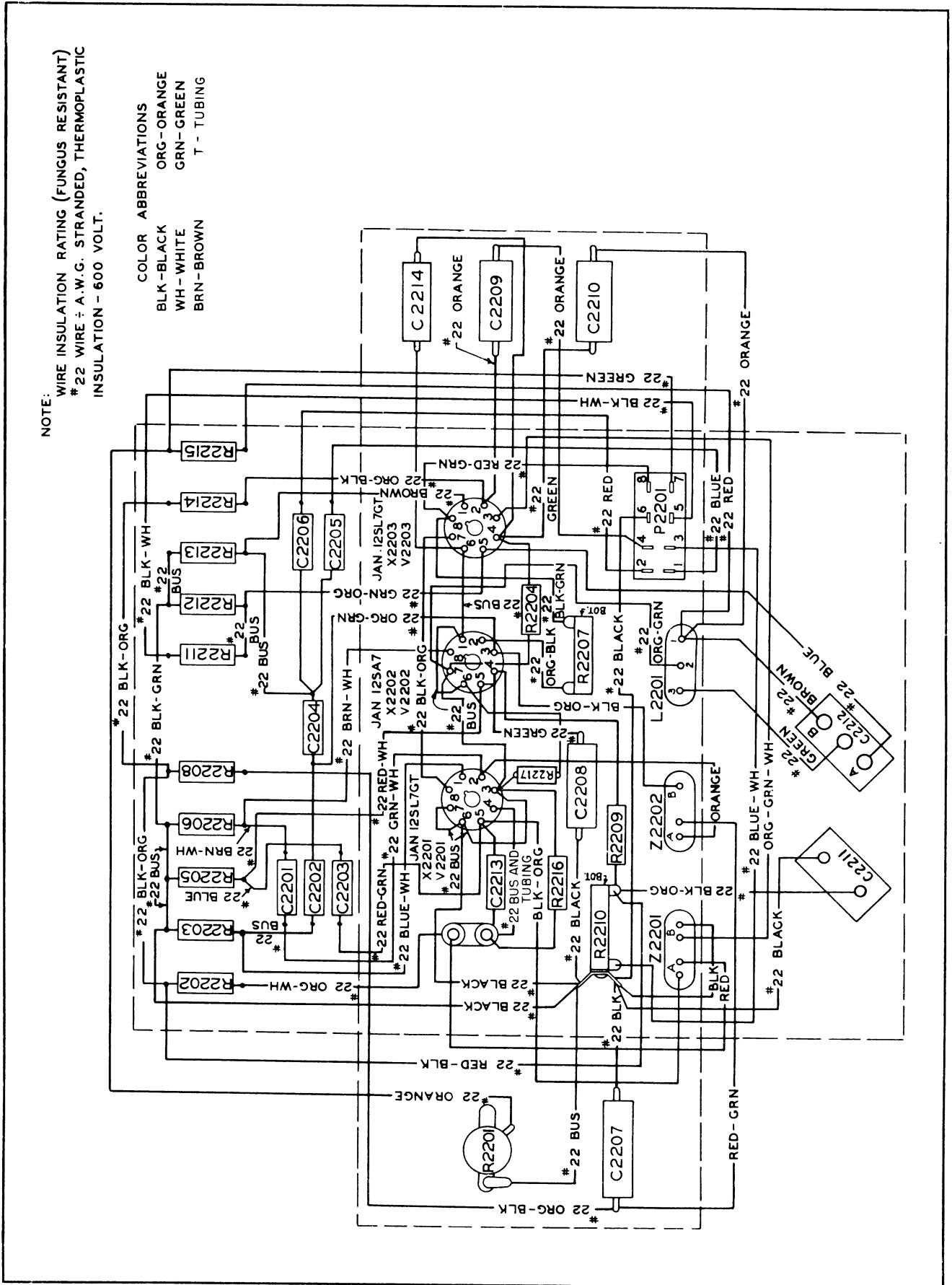

Figure 8-36. MCW-CFI Unit — Practical Wiring Diagram

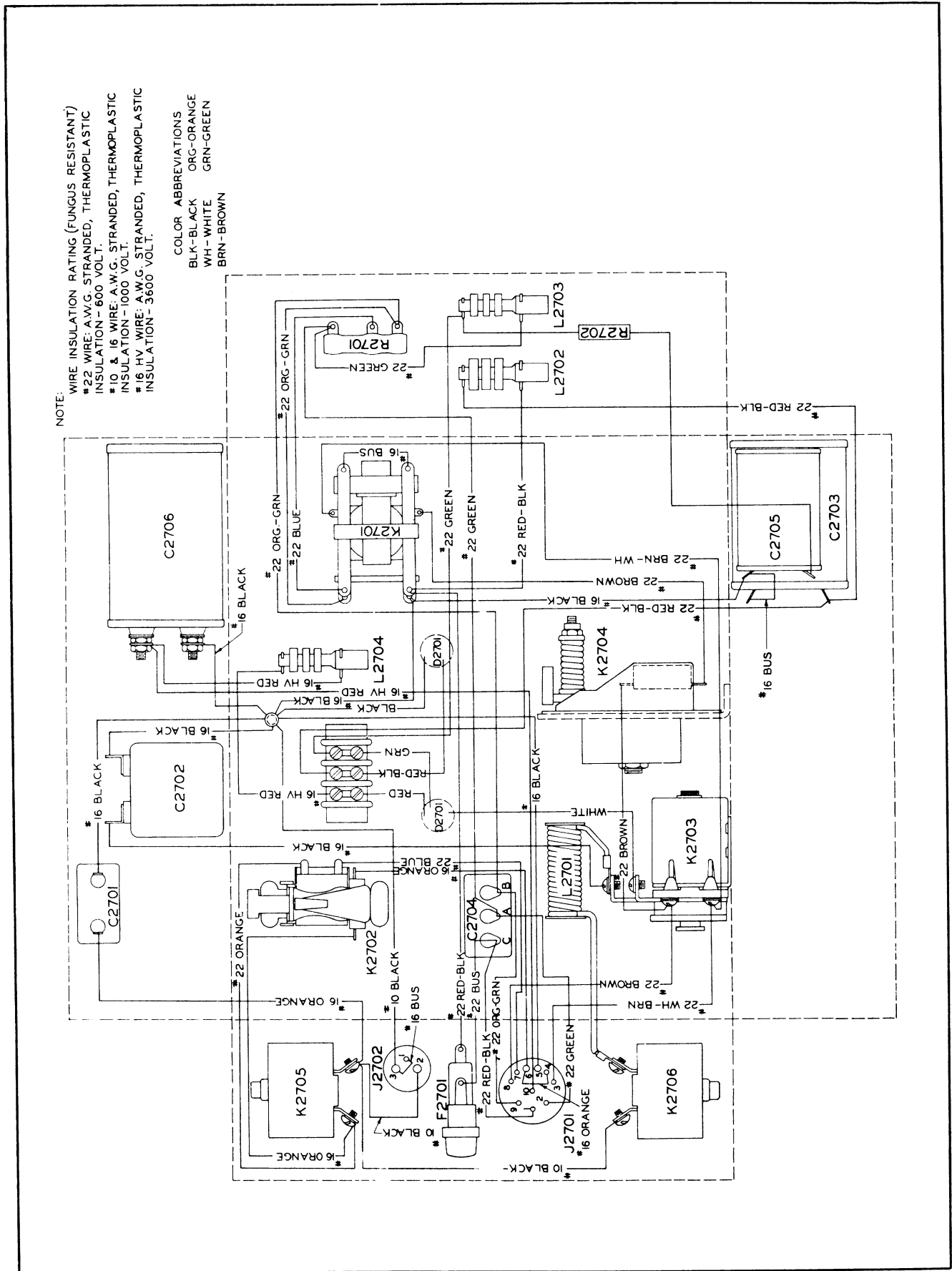
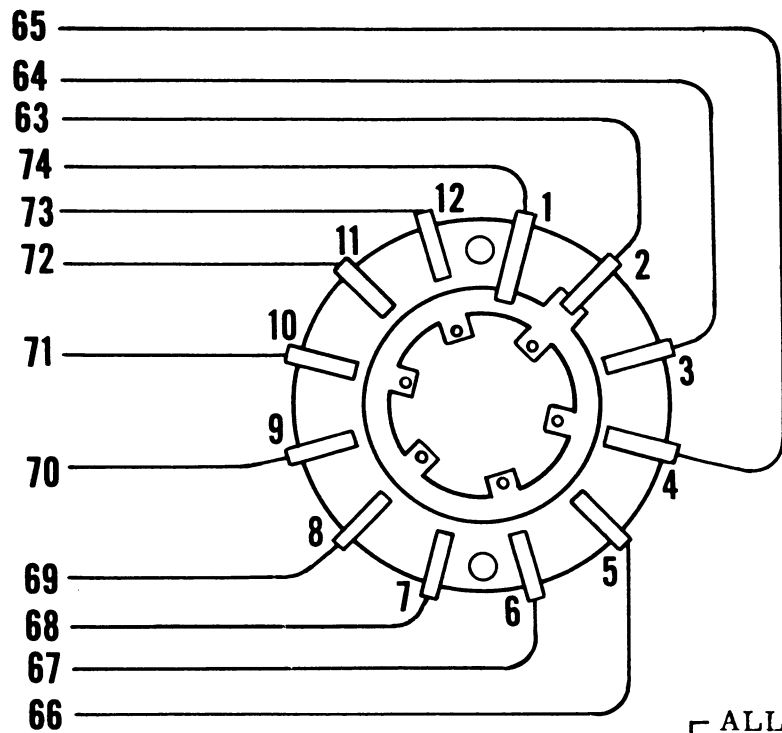

Figure 8-39. Dynamotor Unit DY-17 / ART-13A — Practical Wiring Diagram



S2801

1 [ALL SWITCH SECTIONS ARE VIEWED FROM FRONT OR KNOB END OF SWITCH IN COUNTERCLOCKWISE POSITION

76 78

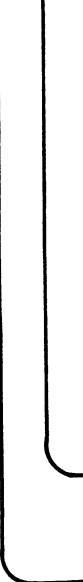

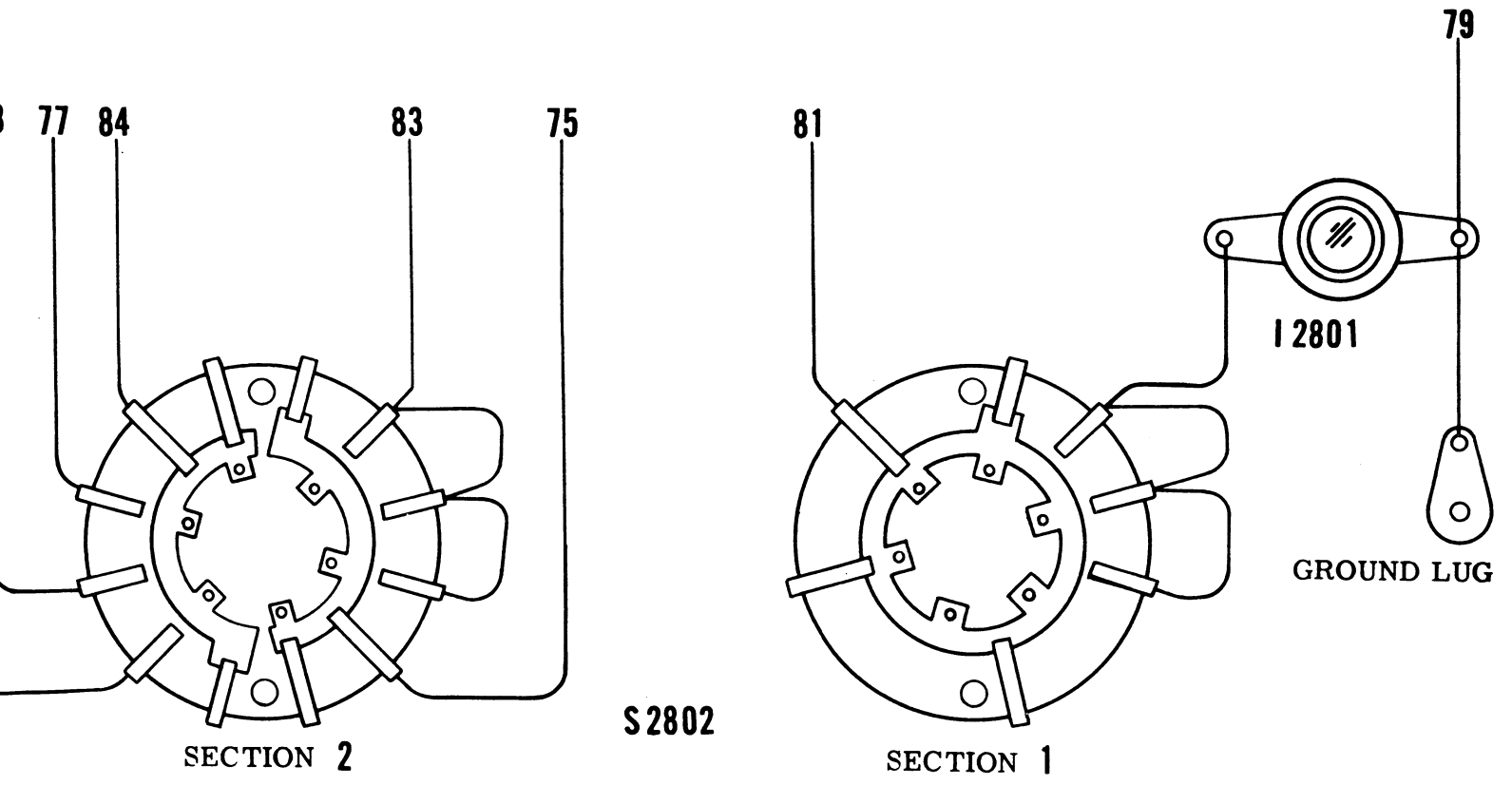

VIEWS FROM
SWITCH IN EXTREME
POSITION

Figure 8-40. Control Panel C-405/A — Practical Wiring Diagram

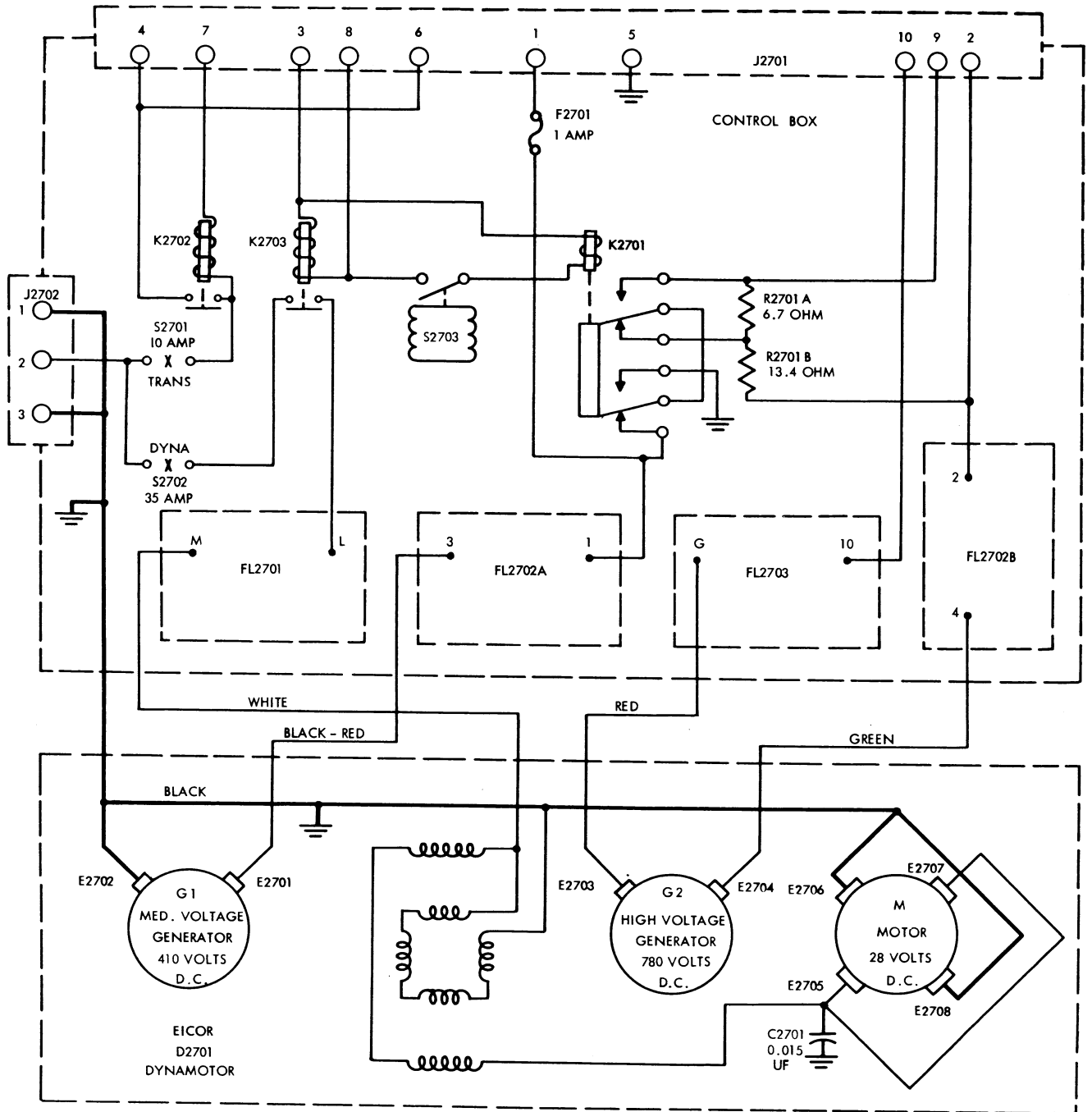
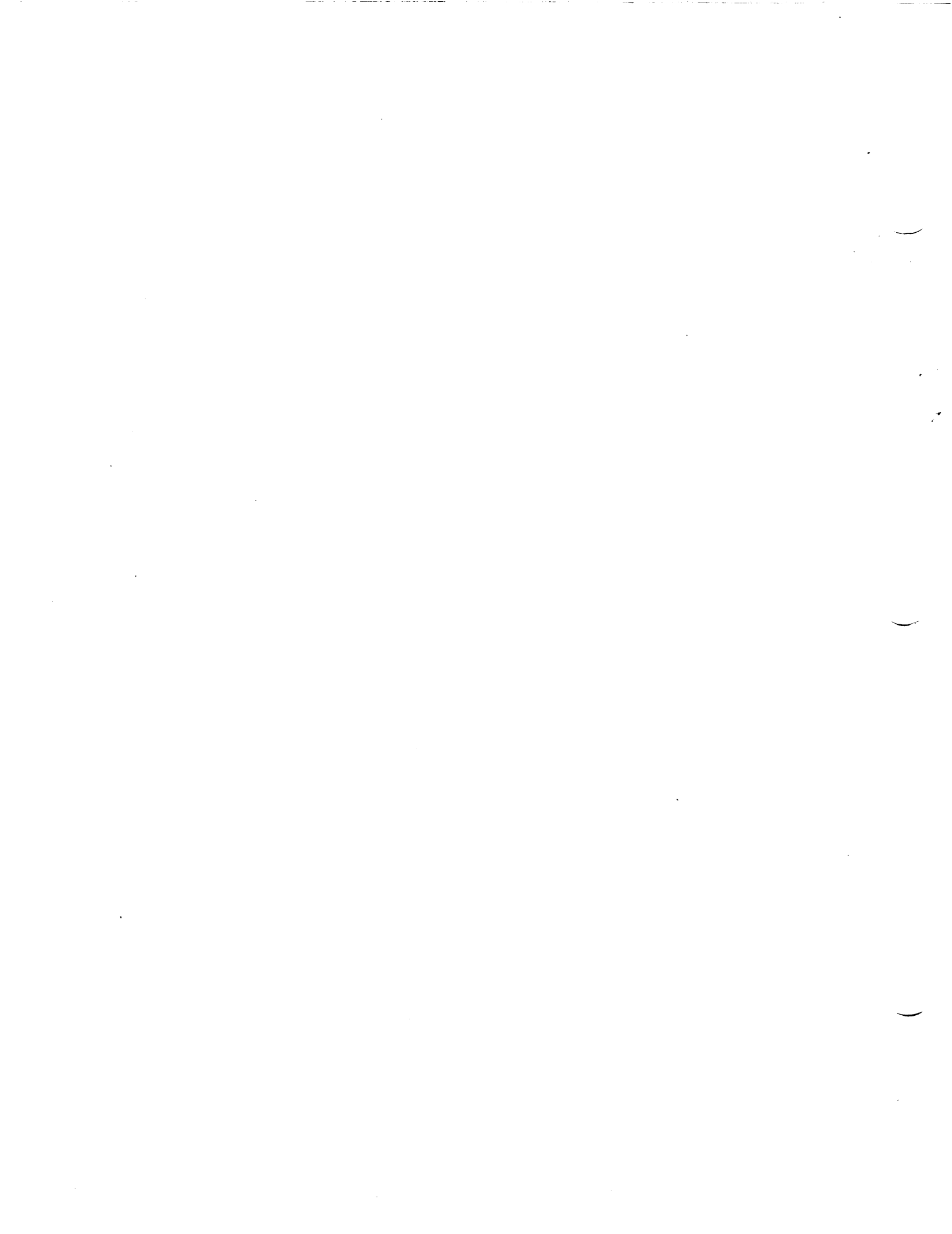

Figure 8-41A. Eicor Dynamotor DY-17A/ART-13A—Schematic Diagram



WIRE TABLE									
EACH CABLE FOR THIS EQUIPMENT SHALL BE IDENTIFIED IN THE AIRPLANE WIRING DIAGRAM AND SHALL BE LABELED ON THE AIRPLANE WIRING IN ACCORDANCE WITH SPEC. AN-W-14, EXCEPT THAT THE CABLE NUMBER OF THE CABLE IDENTIFICATION CODING SHALL BE AS ASSIGNED HEREIN. (EXAMPLE OF THE FIRST WIRE IN THE TABLE BELOW)									
○ RL3A20 ○									
REF NOTE	WIRE NO.	MAX OPER. VOLTS	MAX ALLOWABLE RESIST. IN OHMS (71°C)	MIN CABLE SIZE PERMITTED	REF NOTE	WIRE NO.	MAX OPER. VOLTS	MAX ALLOWABLE RESIST. IN OHMS (71°C)	MIN CABLE SIZE PERMITTED
	3	220	△	20		70	30	△	20
4	11	15	△	20		71	30	△	20
	16	0	0.05	16		72	30	△	20
△	17	30		16		73	30	△	20
	24	220	△	20		74	30	△	20
11	25	0	0.001	14		75	30	△	20
5	26	60	△	14		76	30	△	20
5	27	60	△	14		77	30	0.8	20
						78	30	△	20
						79	0	0.02	16
△	51	30		8		80	30	△	18
	52	0	0.001	8		81	30	△	20
	53	400	△	20		82	30	△	20
	54	10	△	20		83	30	△	20
	55	30	△	20		84	30	0.8	20
	56	30	0.1	18		85	220	△	20
	57	0	0.025	14		86	220	△	20
	58	30	0.05	14		88	15	△	20
	59	30	△	20	4	89	15	△	20
	60	30	0.8	20		90	0	0.02	16
	61	10	△	20	11	91	0	0.001	14
10	62	1150	△	16		92	0	0.05	18
	63	30	△	20		93	30	△	20
	64	30	△	20		849	AA	5000	10
	65	30	△	20		7,849	BB	5000	10
	66	30	△	20		7,849	CC	5000	10
	67	30	△	20		6,849	DD	5000	10
	68	30	△	20		6,849	EE	5000	10
	69	30	△	20					

5. WHEN ANTENNA COUPLING UNIT CU-92/APN IS NOT INSTALLED, DELETE CABLE NO. 27A, AND CONNECT CABLE NO. 26A TO RECEIVER TERMINAL ON RADIO TRANSMITTER T-47A/ART-13.

4. SWITCH AN3023-3 SHALL BE INSTALLED WITHIN EASY REACH OF THE RADIO OPERATOR, AND SHALL BE LABELED "NORMAL" AND "MONITOR" AS SHOWN, WHEN THE SWITCH LEVER IS IN NORMAL POSITION, CABLE NO. 11C SHALL BE CONNECTED TO CABLE 89B THROUGH THE SWITCH AS SHOWN.

3. WHEN REMOTE CONTROL IS NOT REQUIRED, DELETE CONTROL UNIT C-87/ART-13, PLUG U-6/U, CONTROL PANEL C-405/A, TERMINAL STRIP 2, AND ALL CABLES CONNECTED THERETO. CABLES NO. 80A, 82A, 85A, 86A, 88A, 89A, AND 90A SHALL BE CONNECTED TO PLUG U-8/U ON RADIO TRANSMITTER T-47A/ART-13 AND TO TERMINAL STRIP 1 AS INDICATED.

2. WHEN CONTROL UNIT C-87/ART-13 IS INSTALLED INSTEAD OF CONTROL PANEL C-405/A, TERMINAL STRIP 2 IS NOT REQUIRED. PLUG U-6/U ON CONTROL UNIT SHALL BE CONNECTED TO PLUG U-8/U ON RADIO TRANSMITTER T-47A/ART-13 AND TO TERMINAL STRIP 1 WITH THE RESPECTIVE CONNECTIONS AS INDICATED, DELETE CABLES NO. 80D AND 82C AT TERMINAL STRIP 1 WHEN CONTROL PANEL C-405/A IS INSTALLED.

1. CONTROL PANEL C-405/A IS FURNISHED WITH CABLES ATTACHED, WHICH ARE LABELED WITH THE RESPECTIVE WIRE NUMBERS AS INDICATED.

12. WHEN INSTALLATION OF ANTENNA LOADING UNIT CU-32/ART-13A IS REQUIRED, PLUG U-11/U CONNECTS TO RADIO TRANSMITTER T-47A/ART-13. SEE DRAWING AD 3670.

11. GROUND CONNECTIONS FOR CABLES NO. 25A AND 91A SHALL BE MADE TO THE METAL FRAME OF THE AIRCRAFT. REMOVE ALL PAINT AT THE POINT OF CONTACT. THE GROUND LEADS SHALL BE KEPT AS SHORT AS POSSIBLE WITH ONLY ENOUGH SLACK TO ALLOW FREE MOVEMENT OF THE UNIT ON ITS SHOCK MOUNT.

10. CABLE NO. 62A SHALL BE HIGH VOLTAGE CABLE PER USAF SPEC. NO. 32615.

9. THE CONTRACTOR IS NOT REQUIRED TO LABEL CABLES NO. AA, BB, CC, DD, AND EE.

8. TO PREVENT CORONA DISCHARGE AT HIGH ALTITUDES, ANTENNA LEADS AA, BB, CC, DD, AND EE SHALL BE TEFLON INSULATED CABLE, COMMERCIAL PRODUCT, EQUAL TO AND INTERCHANGEABLE WITH TYPE PFGL-10 AS MANUFACTURED BY THE BOSTON INSULATED WIRE AND CABLE COMPANY, UPHAMS CORNER POSTAL STATION, BOSTON, MASS. THE LEADS SHALL BE SPACED AT LEAST 1-1/2 INCHES FROM ALL METALLIC OBJECTS.

7. THE TOTAL LENGTH OF CABLES NO. BB AND CC SHALL NOT EXCEED 12 INCHES.

6. ANTENNA SHUNT CAPACITOR CU-24/ART-13 AND SWITCH SA-46/ART-13A ARE REQUIRED ONLY WHEN THE FIXED WIRE ANTENNA IS LESS THAN 55 FEET FROM THE TRANSMITTER TO THE FARTHEST END. A JUMPER CABLE NO. DD OR 2 CABLES NO. DD AND EE SHALL BE INSTALLED ONLY WHEN REQUIRED. THE GROUND RETURN CIRCUITS ARE ACCOMPLISHED THROUGH THE BONDING OF THE BASE OF THE CAPACITOR.

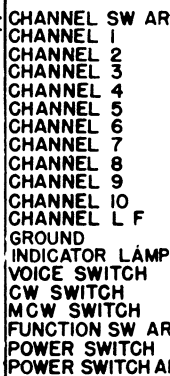
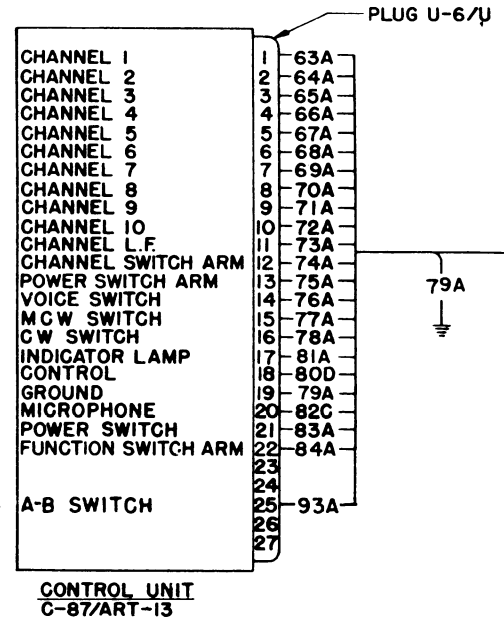

*Applies only to AN/ART-13B

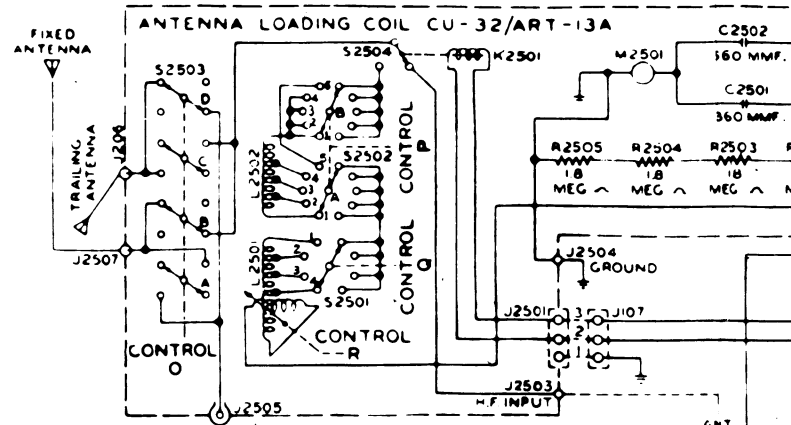

Emerson, Ohio, and Fractional Motors have different values for these capacitors:

Emerson	C132	4000
Ohio	C139	3500
Fractional	C141	2000

Emerson	C133	4000
Ohio	C140	3500
Fractional	C142	2000

NOTE

1. All resistance values are in ohms unless otherwise noted.
2. All capacitor values are in microfarads unless otherwise noted.

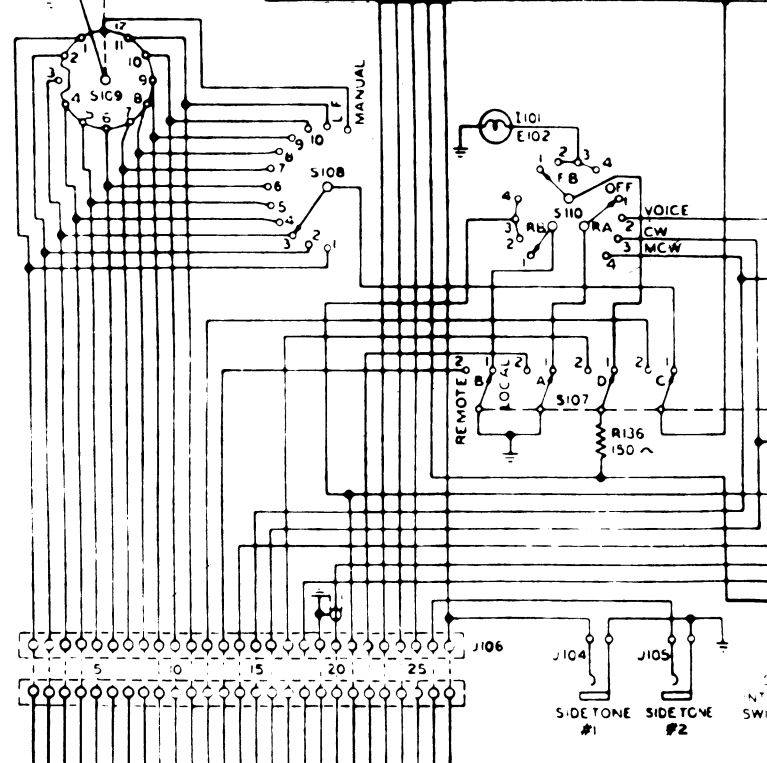
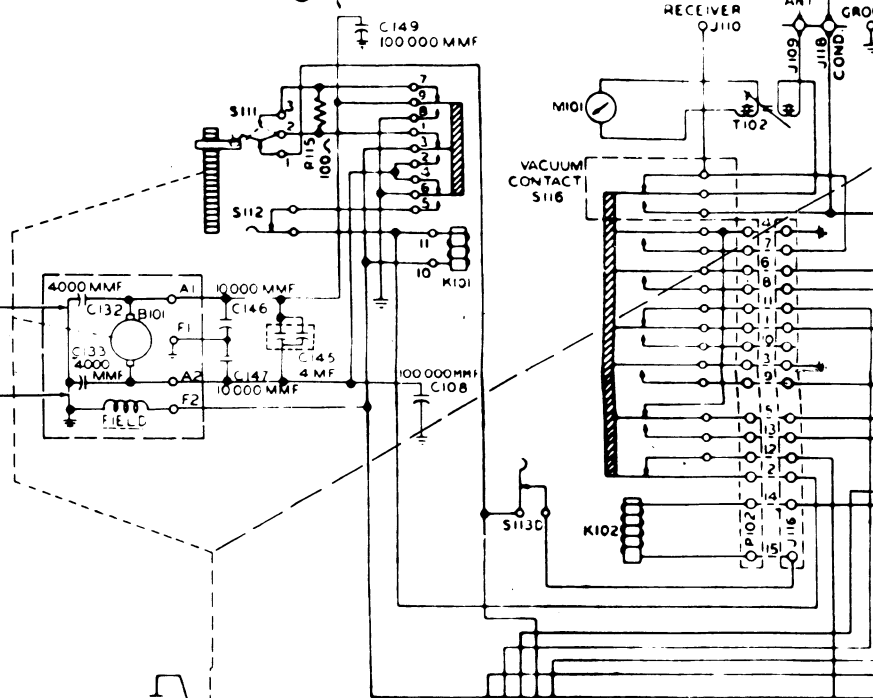

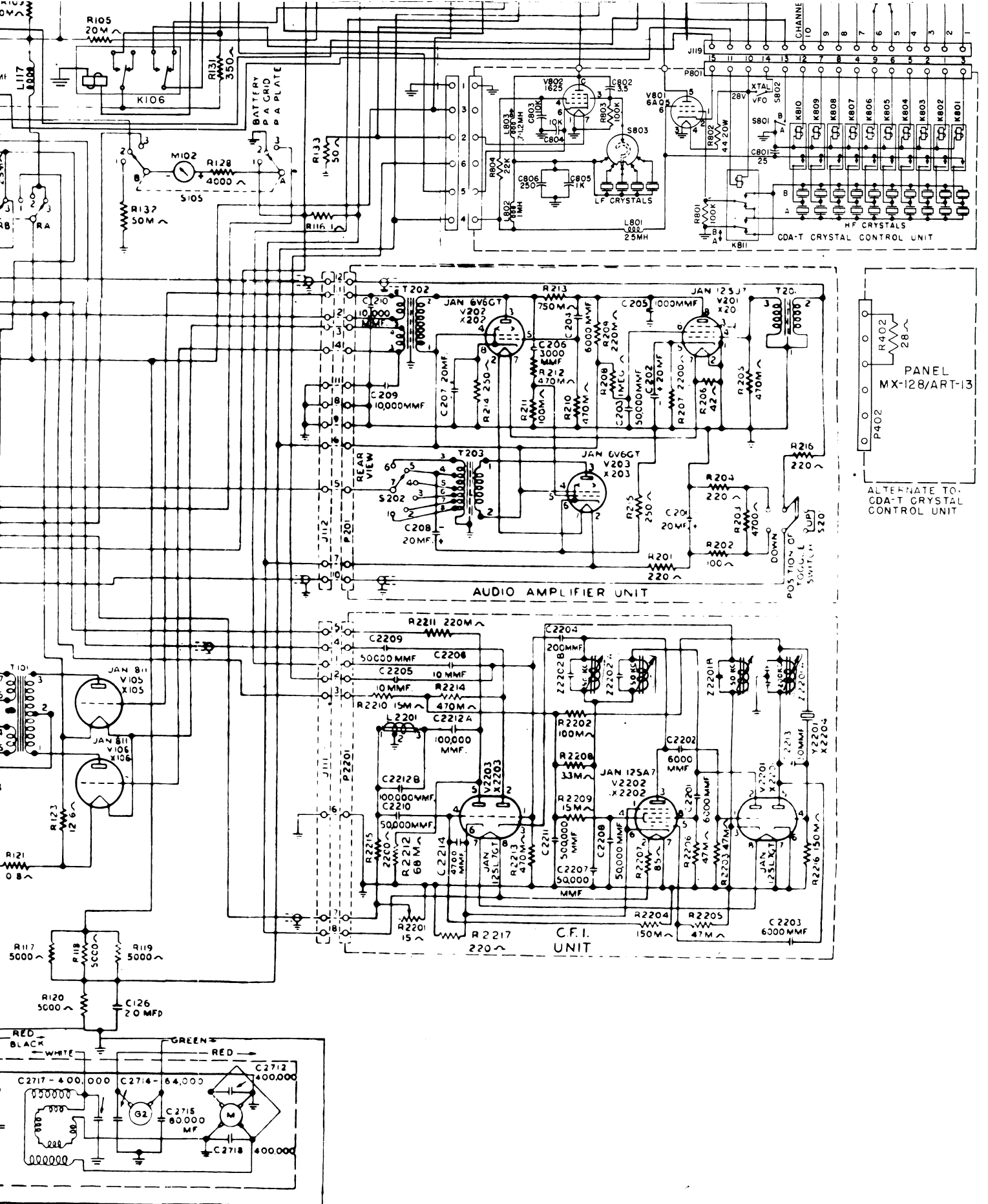

Figure 8-44. Radio Transmitting Set AN ART-13B—Schematic Diagram

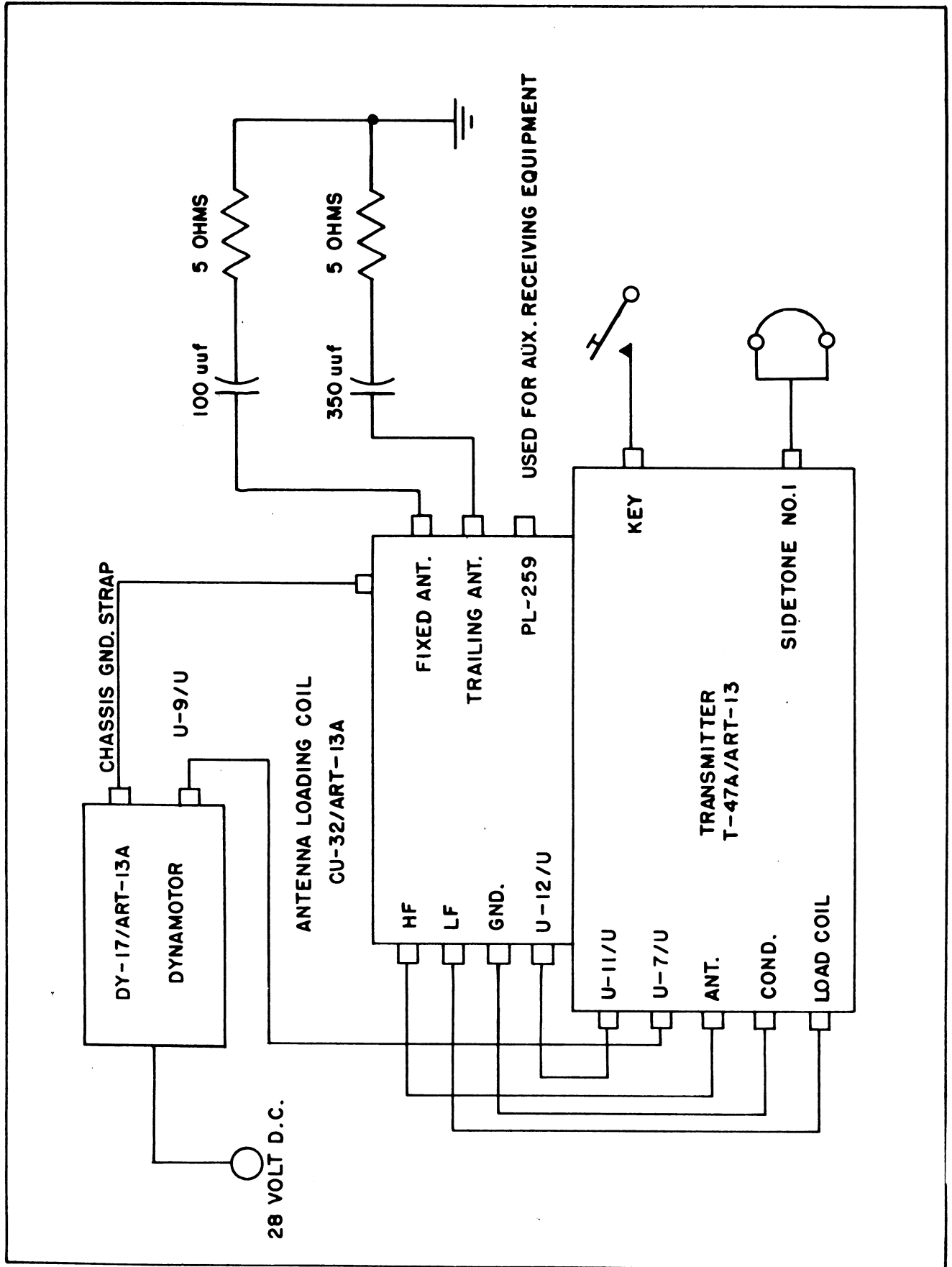

Figure 8-45. Antenna Loading Unit CU-32/ART-13A — Test Inter-Connection Diagram.

