

BIG TC

A quarter of a million volts? All it takes is a transformer, a capacitor, a spark gap, and Tesla's famous coil

By **CHARLES CARINGELLA**, W6NJV

TESLA COILS have fascinated experimenters ever since the early 1900's when Nikola Tesla first experimented with giant coils that produced lightning-like discharges which would span his laboratory—the work of millions of volts of electricity. The Tesla coil described here is smaller than some of Tesla's designs, but it's capable of putting out almost a quarter of a million volts! Brilliant corona discharges as long as a foot or more provide a spectacular display of its intense electrical field, and neon and fluorescent lamps can be excited as far as five feet away.

Intended both as a dynamic demonstrator of electrical principles and as a crowd-attracting science fair project, "Big TC" can be put together for about \$30. However, if a used transformer from a neon sign shop can be secured reasonably, the cost will be even less

WARNING: The voltages used in this project are highly dangerous. Inexperienced persons should seek aid from an instructor or other expert before building it.

COVER STORY

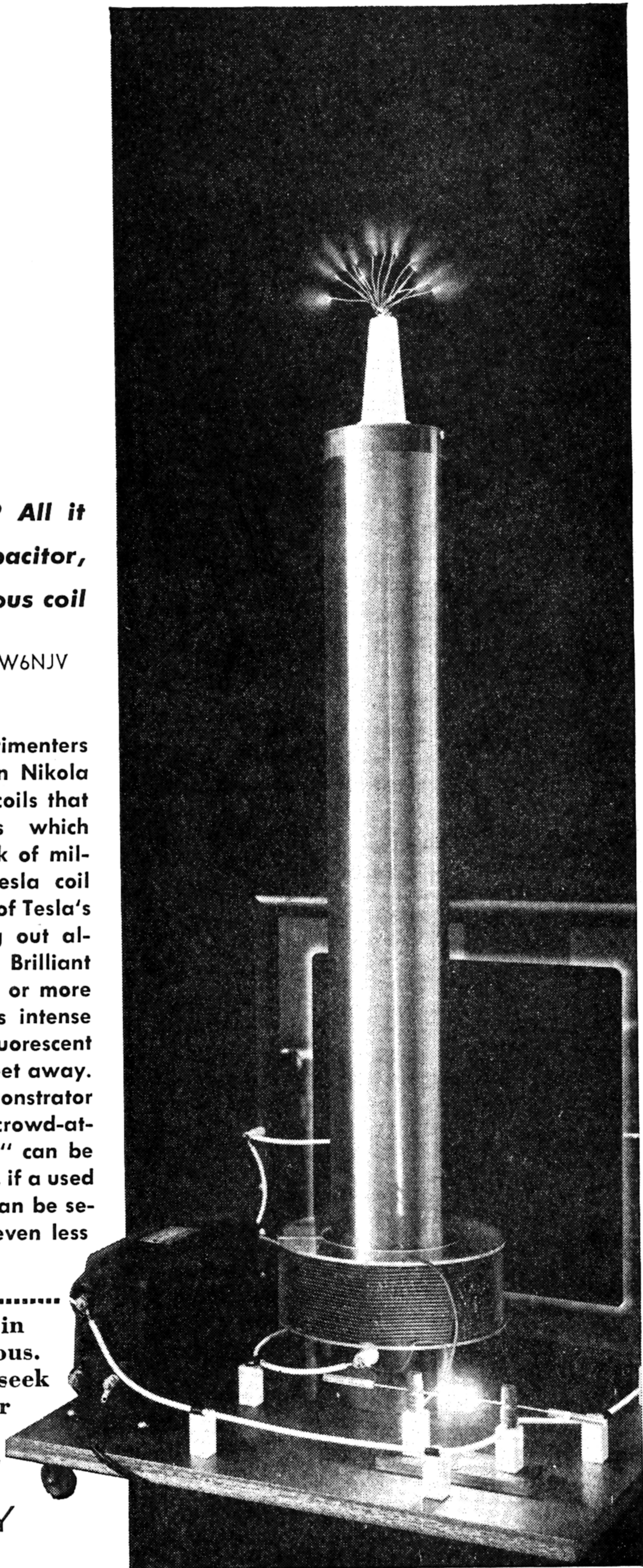

BIG TC

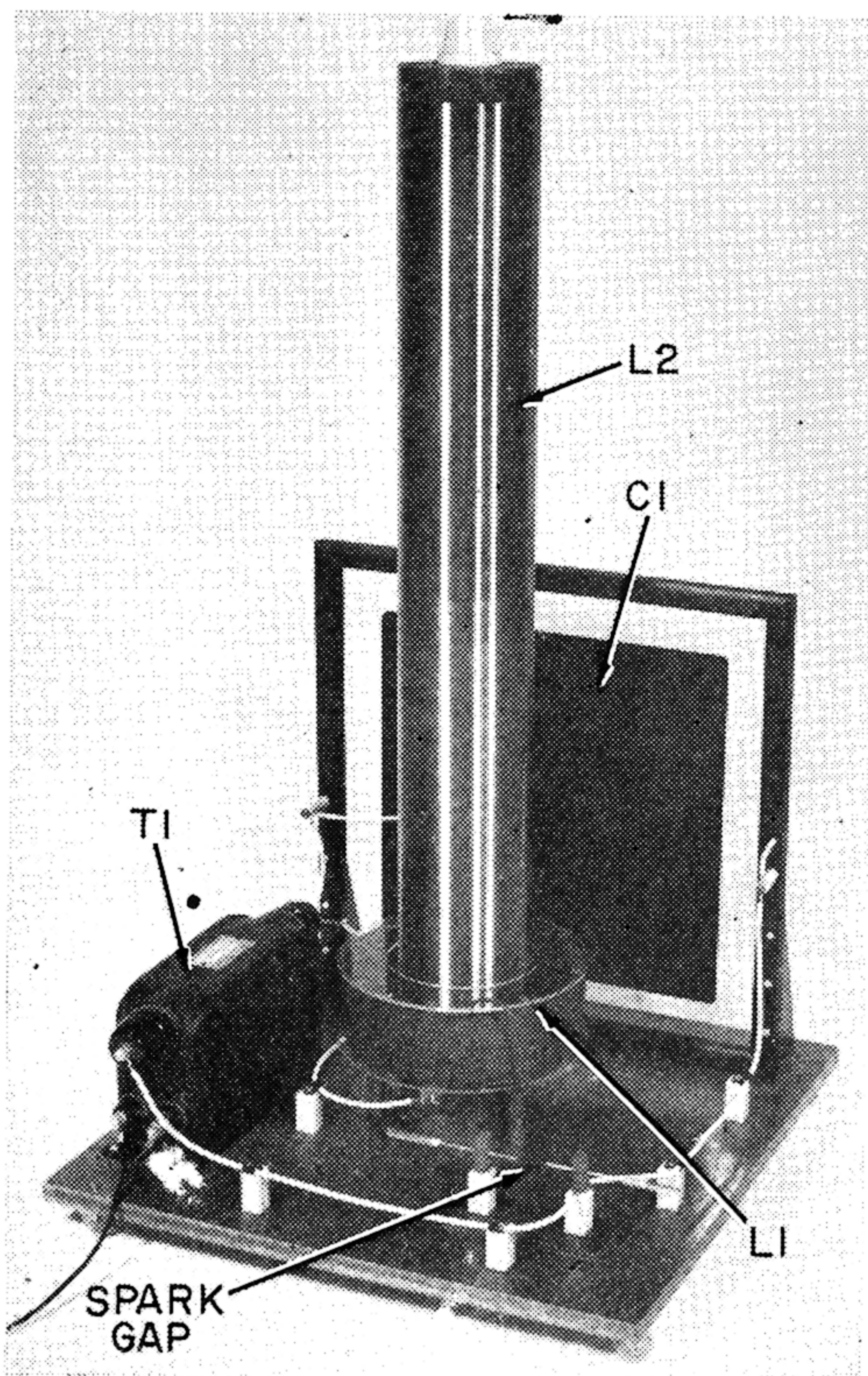

Mount L1-L2 in center of base, T1 and C1 at edges. A bigger base and greater component spacing will permit greater voltage output with less arcing.

As shown in the schematic diagram above, *T1* steps the household line voltage up to 12,000 volts. The transformer is the type commonly used to operate neon signs. A high-voltage glass-plate capacitor, *C1*, is connected directly across the high-voltage secondary winding of *T1*. The capacitor serves as an energy storage device, charging up to *T1*'s secondary voltage and then discharging in response to the 60-cycle a.c. voltage.

Discharging of *C1* is through the spark gap into coil *L1*. Each time the spark gap "fires," a high current flows through *L1*. The larger capacitor *C1* is made, the larger will be the current through *L1*. Discharges across the spark gap produce extremely jagged pulses of power which are very rich in r.f. harmonics. The energy—due to the values

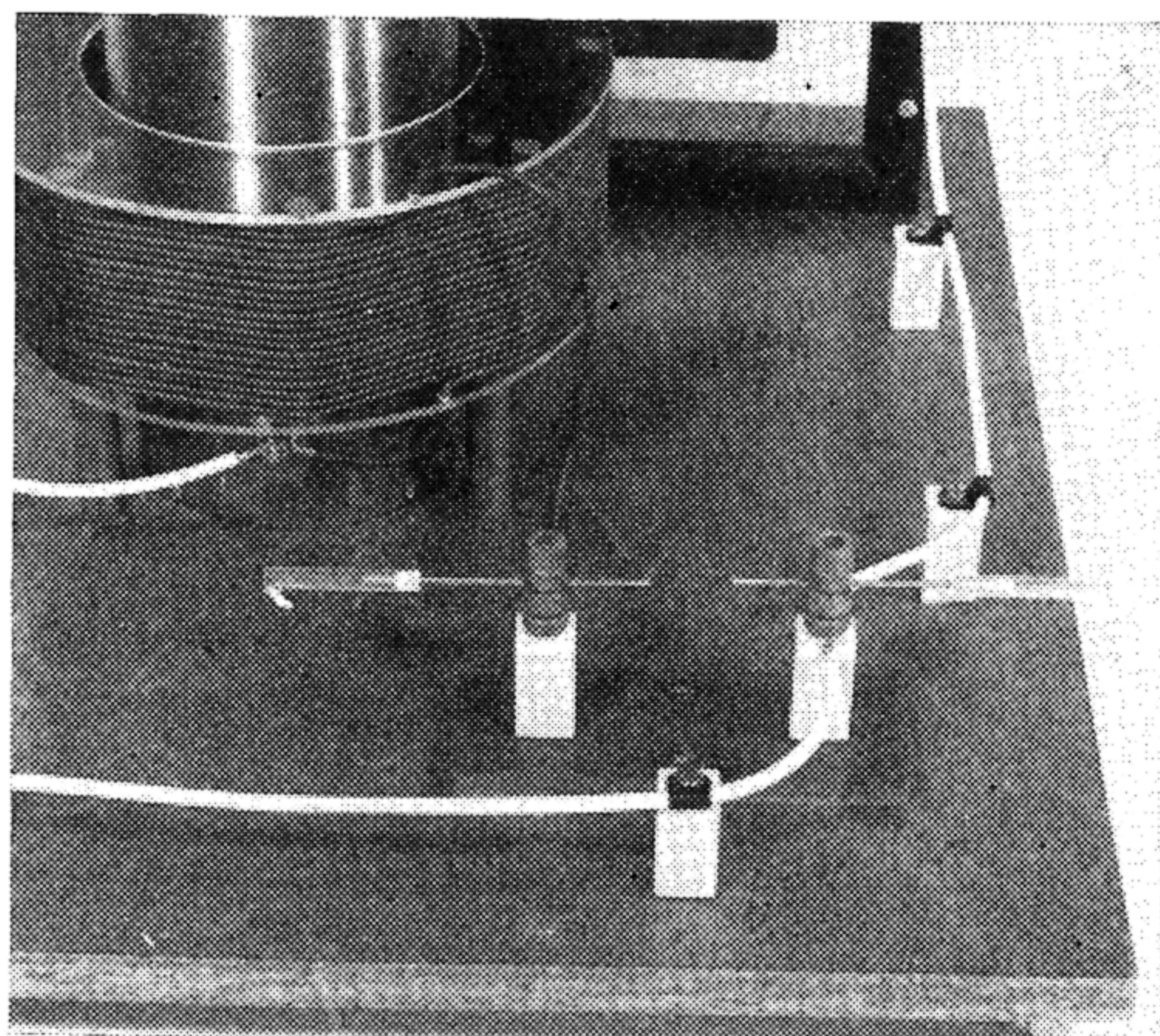

Spark gap generates r.f. energy to excite coil. It consists of two copper rods mounted on standoffs.

The secondary of a neon sign transformer is usually grounded internally to the metal case. Connect bottom of Tesla coil secondary to case and to a good external ground, such as a water pipe. This precaution will keep danger of a short circuit in transformer at a bare minimum.

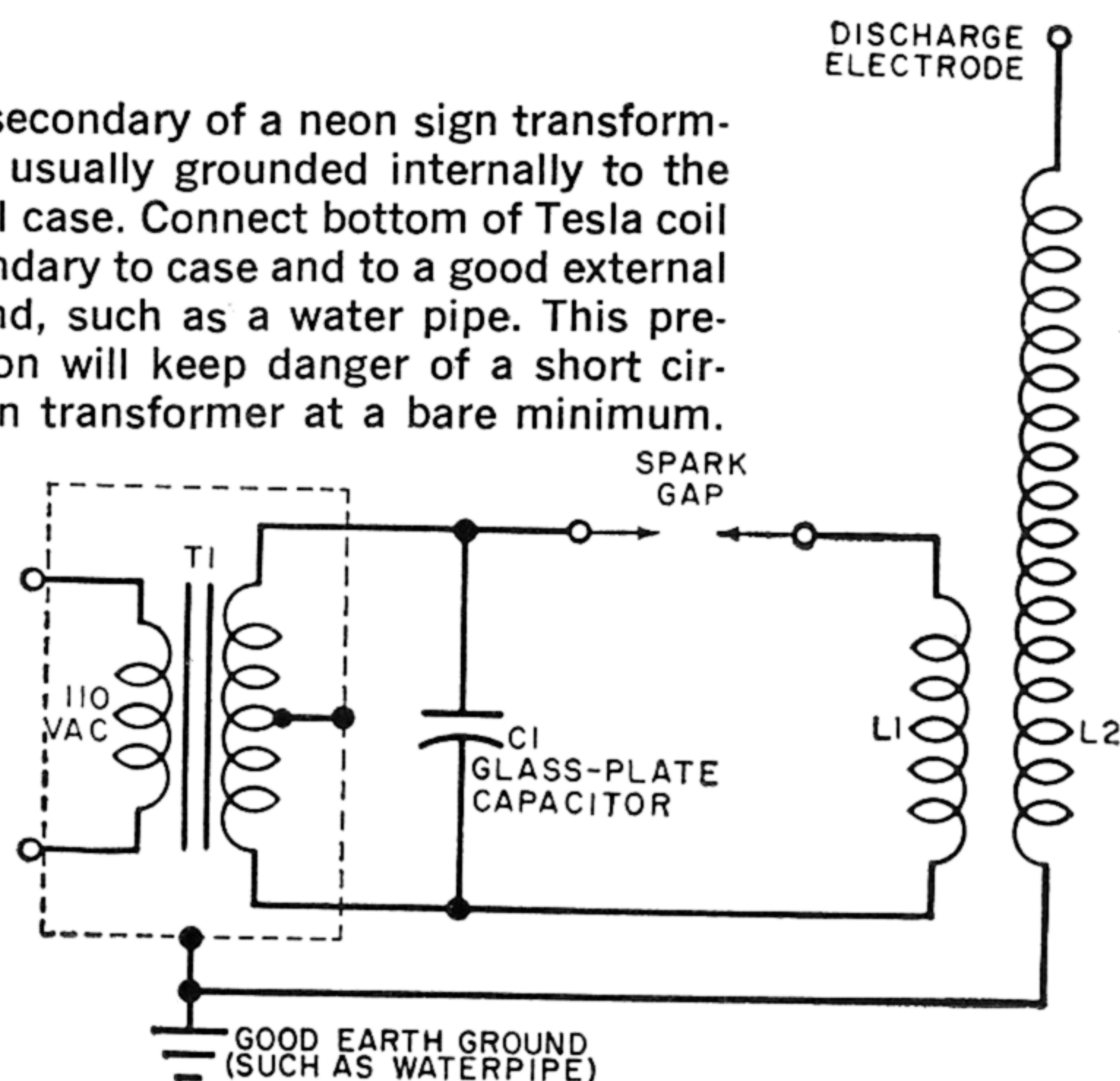

of the components used—is greatest in roughly the 100-kc. region.

Windings *L1* and *L2* form an air-core step-up transformer, with *L1* the primary and *L2* the high-voltage secondary. The voltage at *L2* will be 75,000 to 250,000 volts depending on the size of *C1*.

Design and Layout. The prototype of "Big TC" was built on a plywood base measuring $\frac{3}{4}$ " x 22" x 22", although a larger base would be desirable for high-voltage units to prevent arcing between *L2* and *T1* and *C1*. Mount *L2* in the center of the base and *T1* and *C1* as close to the edges as possible; if you plan to operate the unit at voltages exceeding 100,000 volts, make the base 3' x 3' for even greater separation between components.

Power transformer *T1* is the only

Constructed for classroom demonstration, the author's unit was mounted on mahogany veneer plywood which was sanded and covered with five coats of plastic varnish. Other finishing touches were wood tape veneer around the edges, and nylon casters to make the unit easy to move.

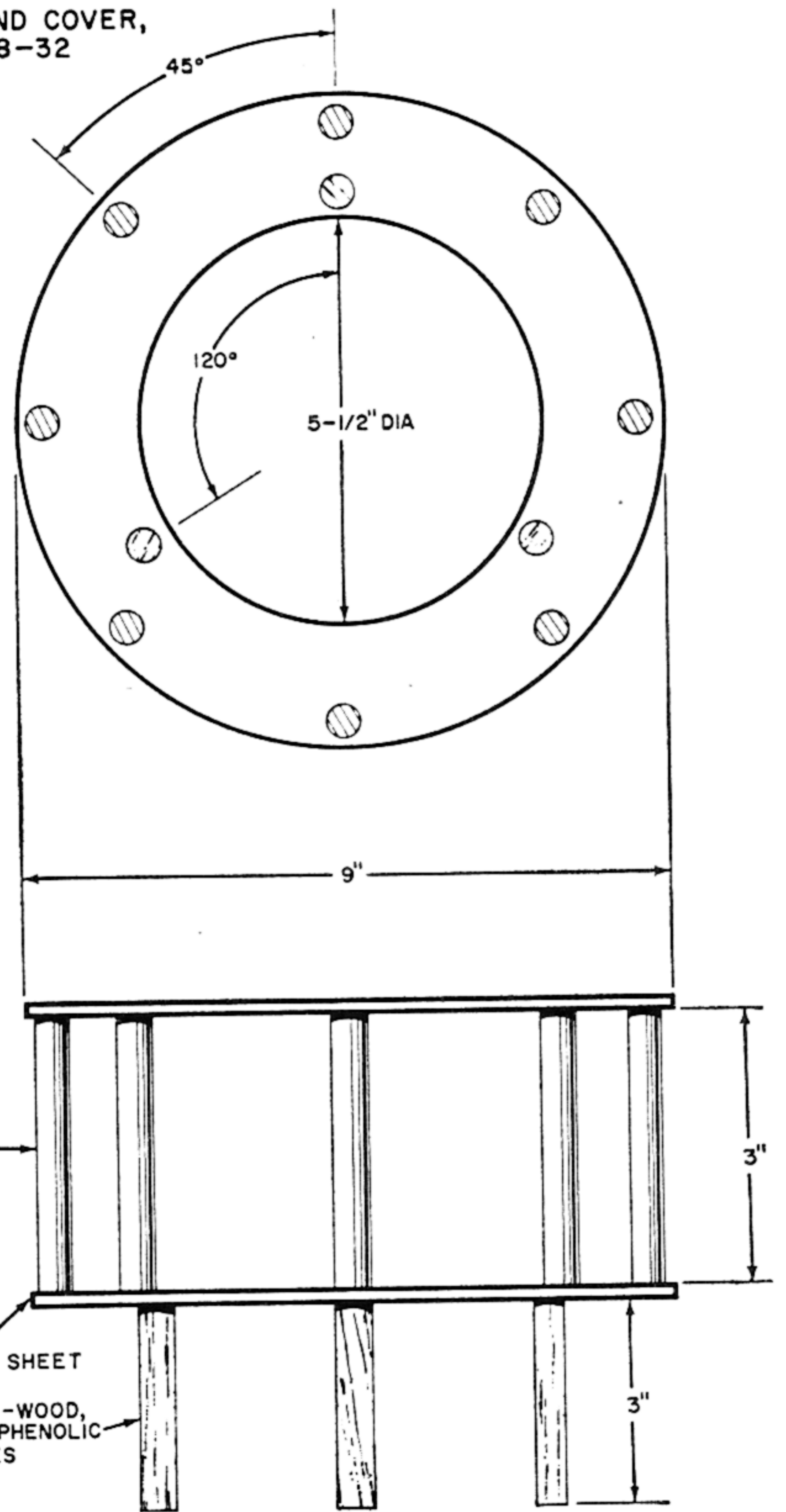
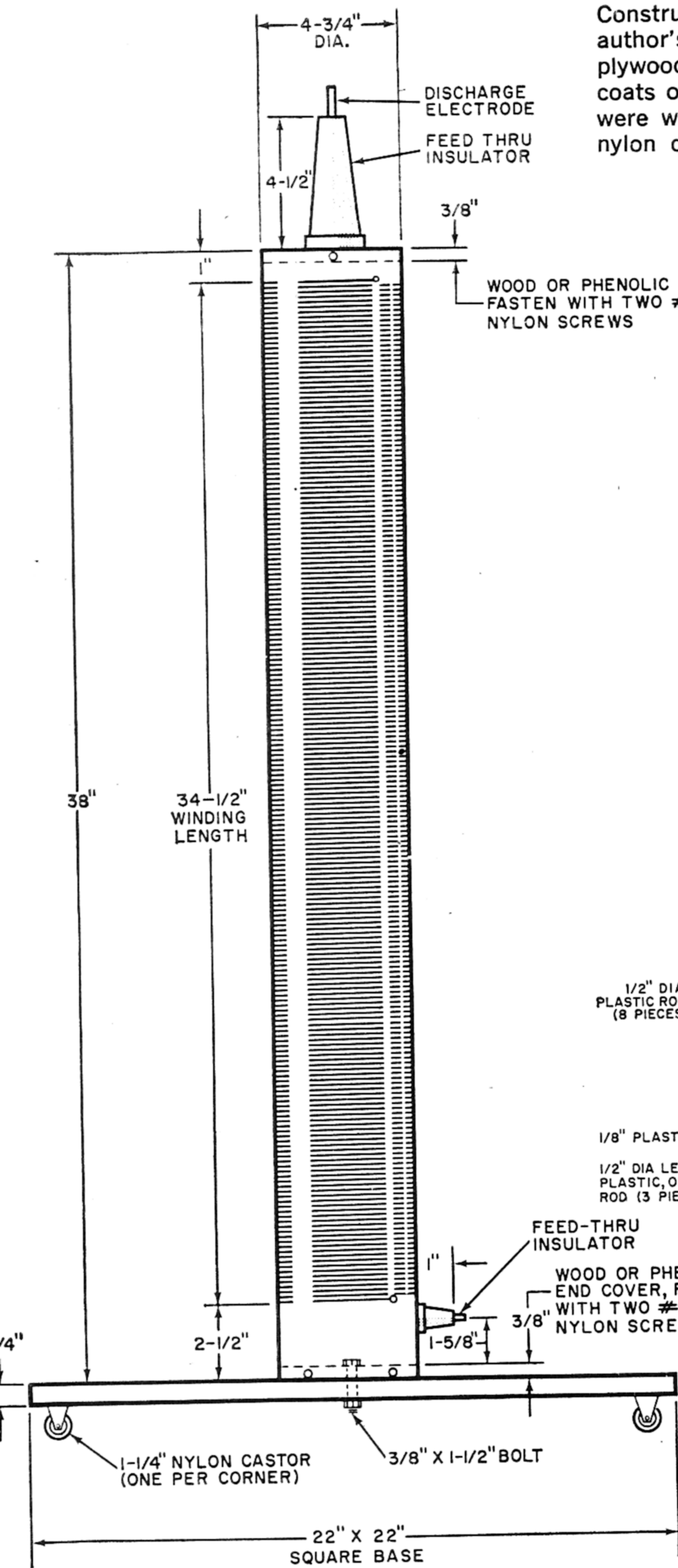

Form for L1 with center cut out to take base of L2 is shown above. Polystyrene was used, but wood or cardboard can be substituted. The critical dimension is the outside diameter; less than 9" will result in arcing between coils L1 and L2.

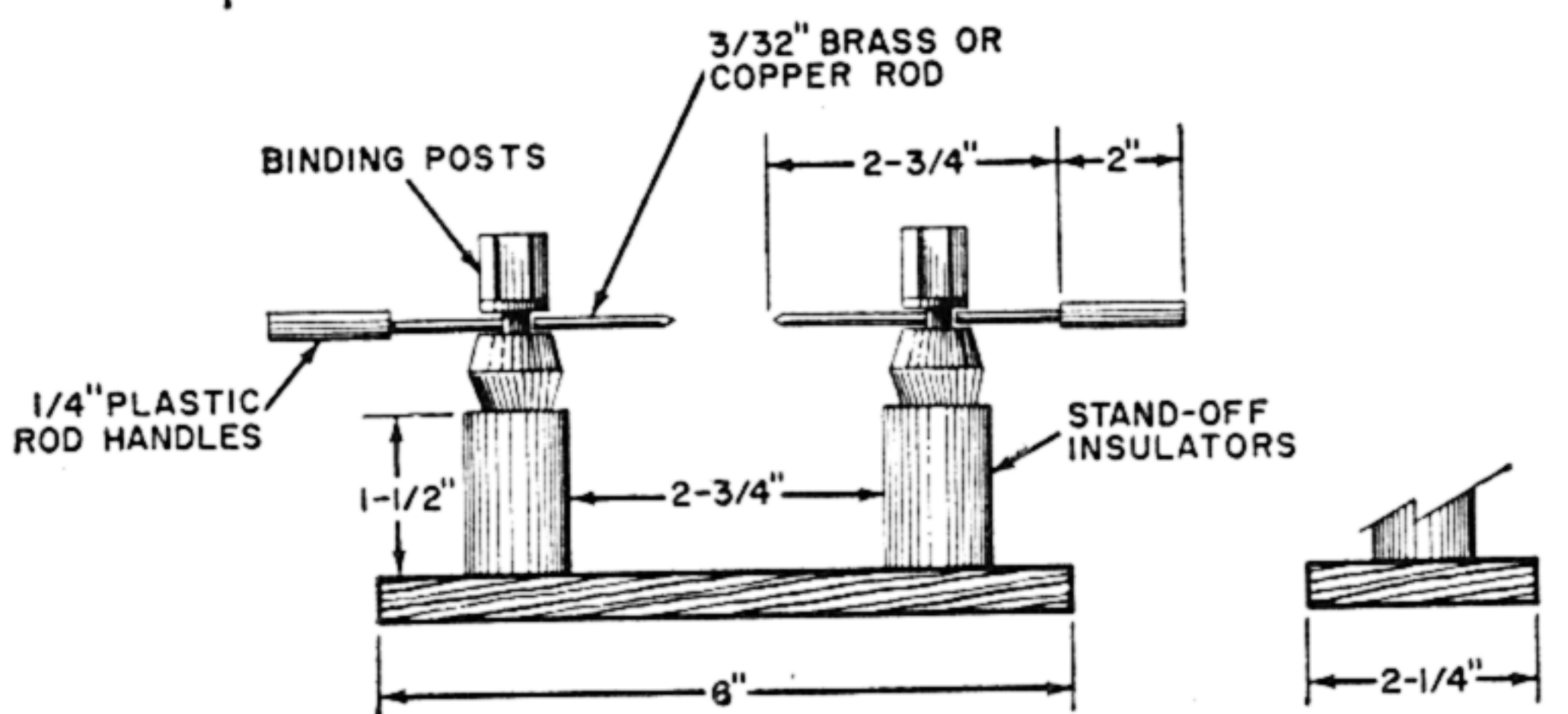

The various dimensions of the prototype coil are indicated in the drawing; none is particularly critical. Note that space has been left at each end of coil, and that stand-off insulators are used to bring out the ends. Nylon screws or glue must be used to fasten top end cover to avoid arcing. After winding coil, cover with many coats of acrylic plastic spray. Spray form first if cardboard is used. Details on spark gap are shown at right.

BIG TC

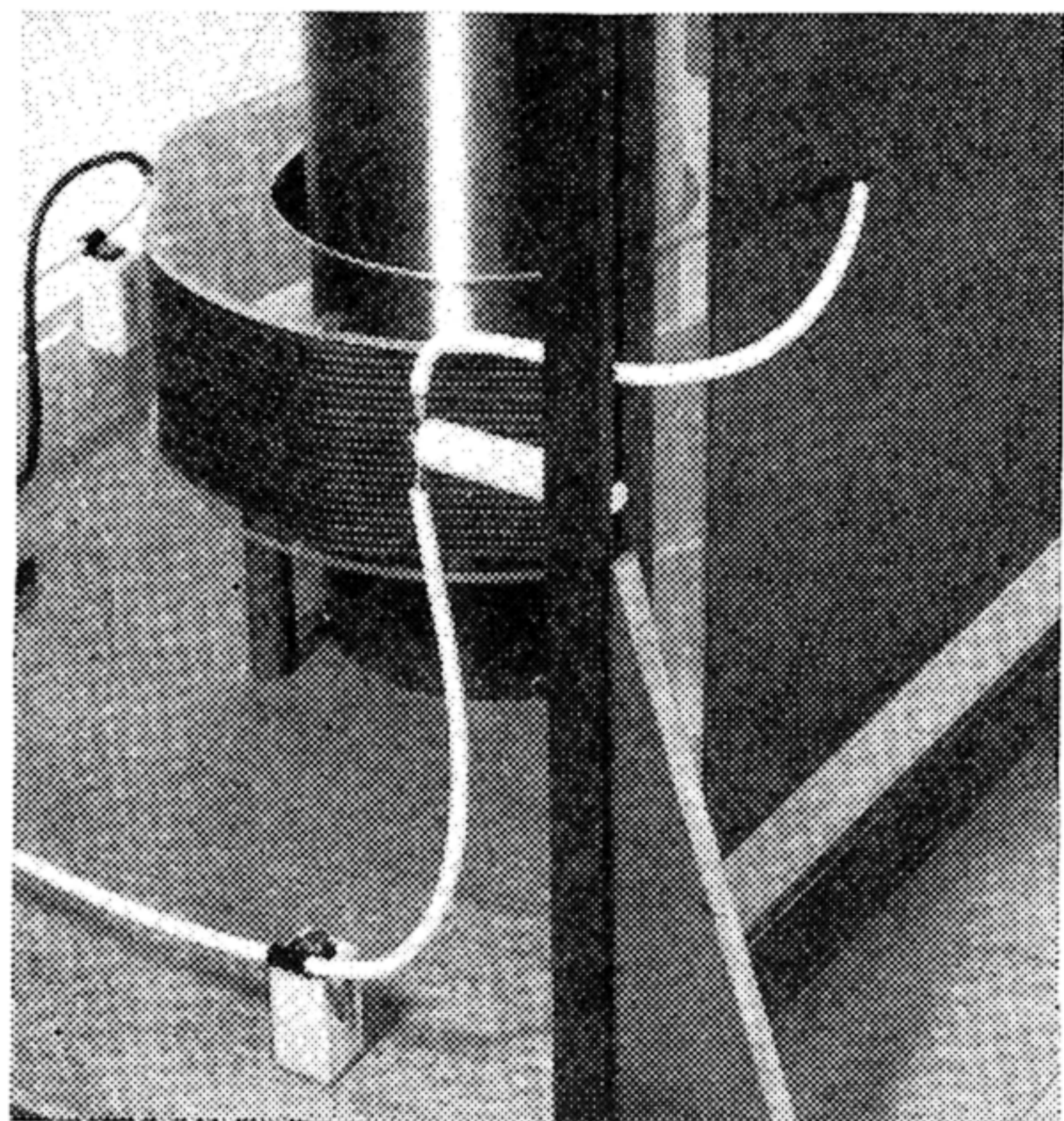

Leads are soldered directly to capacitor plates. Note use of stand-off insulators.

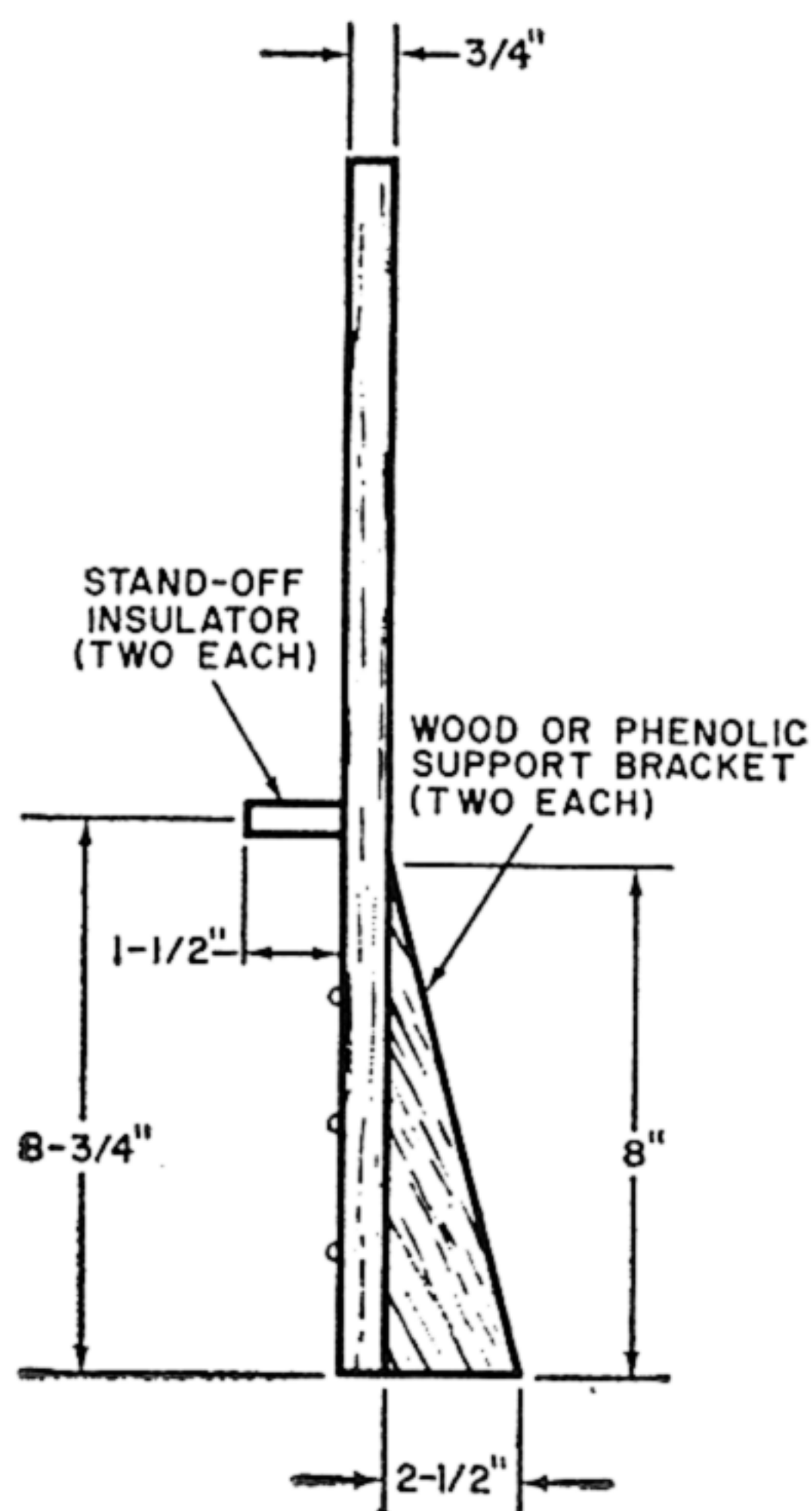
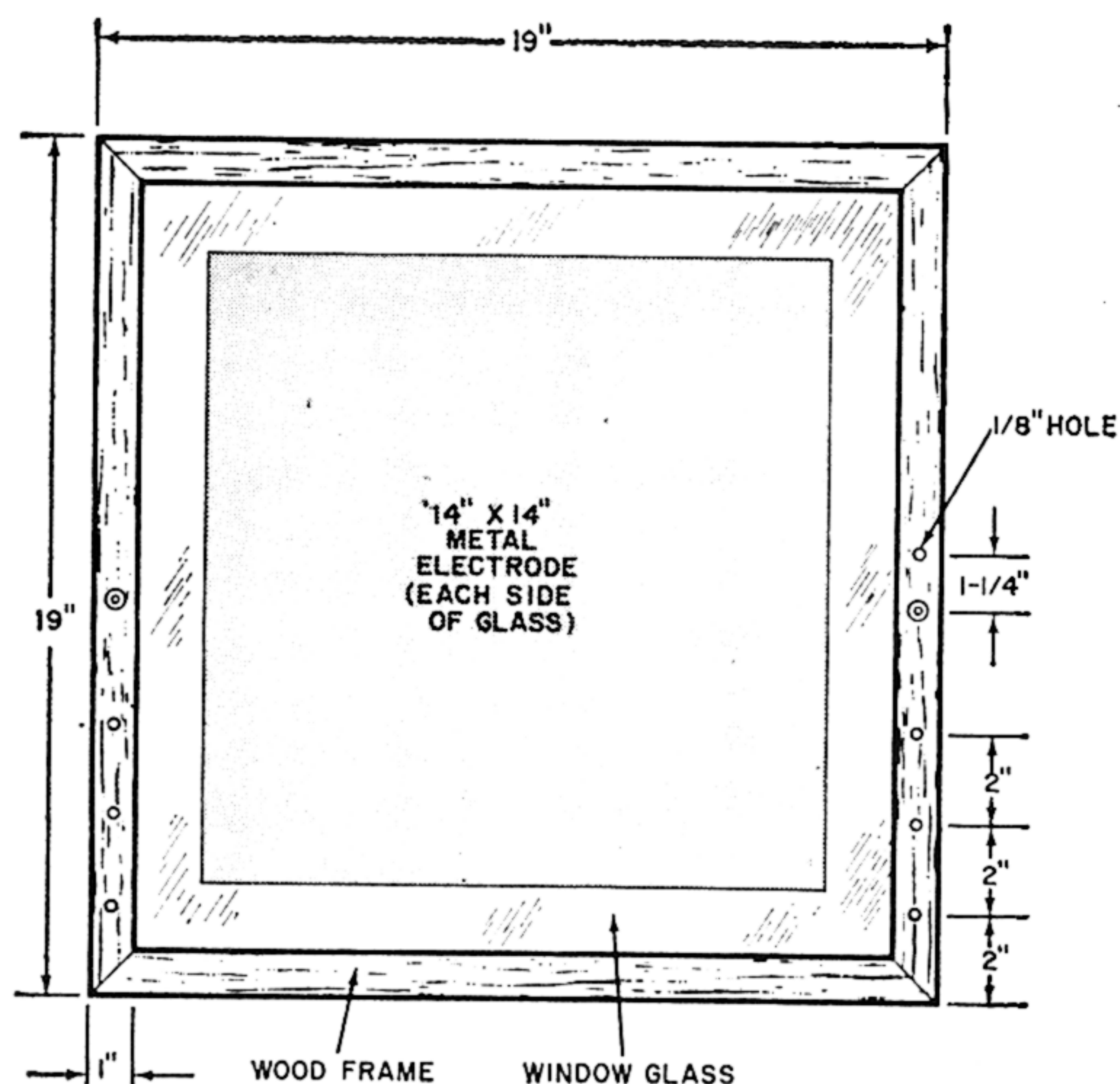

Glue metal plates to glass, leaving a generous margin of glass on all sides (see text). Epoxy glue, contact cement, or any other glue which will form a tight bond can be used. The wood frame protects the glass and makes mounting it possible.

high-cost component. A neon-sign unit rated at 12,000 volts a.c. at 30 ma., it sells for about \$40 new, but used transformers are constantly being salvaged by sign shops, and can be picked up for \$10 to \$20. It is also possible to find neon signs in junk yards, in which case you can probably buy the transformer for practically nothing. The author used a GE unit, No. 51G473, known technically as a "luminous tube transformer." Measuring $9\frac{1}{2}$ " x 6" x 4", it has 2" feedthrough insulators at either end connecting to the high-voltage winding.

Primary coil $L1$ and all connecting leads must be made with high-voltage wire, preferably supported away from the base on 1" ceramic standoff insulators. Test prod wire such as Belden Type 8899 is ideal—it has flexible rubber insulation with a puncture voltage rating of 20,000 volts.

Winding the Coil. For the big coil ($L2$) a phenolic coil form* measuring $4\frac{3}{4}$ " in outside diameter and 38" in length was used. Alternately, cardboard, wood or other insulating materials can be substituted. You can improve these latter types of coil forms by spraying on at least six coats of acrylic plastic spray before winding the wire on them.

The winding itself is done with No. 26 Formvar-insulated wire—two 1-lb. spools (splice them together and keep the solder joint as small as possible) will give you a 2000-turn, tightly spaced coil covering $34\frac{1}{2}$ " of the coil form. There should be extra space between the ends of the winding and the ends of the form—see the drawing on page 95.

The lower end of the coil is terminated at a 1" feedthrough insulator installed in the side of the form, the top end of the coil at a $4\frac{1}{2}$ " feedthrough mounted to the top end of the form. Make the end covers of wood or phenolic discs cut to the inside diameter of the coil form, and mount them in place with

*Tubing can be found in metropolitan areas at surplus houses and establishments which sell plastics (sheets, rods, etc.). Clear acrylic tubing (48" long, $4\frac{1}{2}$ " O.D.) can be ordered from Industrial Plastics Supply Co., 324 Canal St., New York, N. Y. 10013, for \$13.85 including shipping charges and postage; address your order to the attention of Mr. Charles Roth.

This Mark II version of "Big TC" used a second outboard capacitor—increasing the capacity across the primary by 0.0014 uf. Estimated output of the Mark II model was about 130,000 volts. See page 96.

nylon screws (metal screws at the top end would produce corona discharges which could burn the coil form). Alternatively, the top coil cover can be cemented in place with epoxy cement if a sturdy coil form is used. The coil is attached to the base with a $\frac{3}{8}$ " bolt.

Winding the coil is not nearly as difficult as it appears—the author completed the task in about two hours. Spray the entire winding with acrylic plastic for added insulation, moisture protection, and to keep the windings in place. You can't overdo this step—the author used the contents of an entire aerosol spray can on the prototype, applying one thin layer at a time and letting it dry before adding another.

Building the Primary. As shown on page 93, the form for *L1* was made with polystyrene rods and sheeting. While the plastic has excellent insulating qualities and looks attractive, wood or even cardboard can be substituted. If plastic is used, it can be strongly "welded" together with acetone. Regardless of the material used, the form should have an outside diameter of at least 9" to avoid arc-over between *L1* and *L2*. The coil itself (*L1*) consists of 20 turns of heavy test prod wire.

Spark Gap. The spark gap is simply two ordinary binding posts mounted on stand-off insulators. In turn, these are mounted on a phenolic base measuring $\frac{3}{8}$ " x $2\frac{1}{4}$ " x 6". The electrodes are brass and copper rods with a gap on the order of 1" between them. This distance will vary slightly, depending on the size of capacitor *C1*.

Fabricating the Capacitor. The capacitor consists of two 14" x 14" sheets of

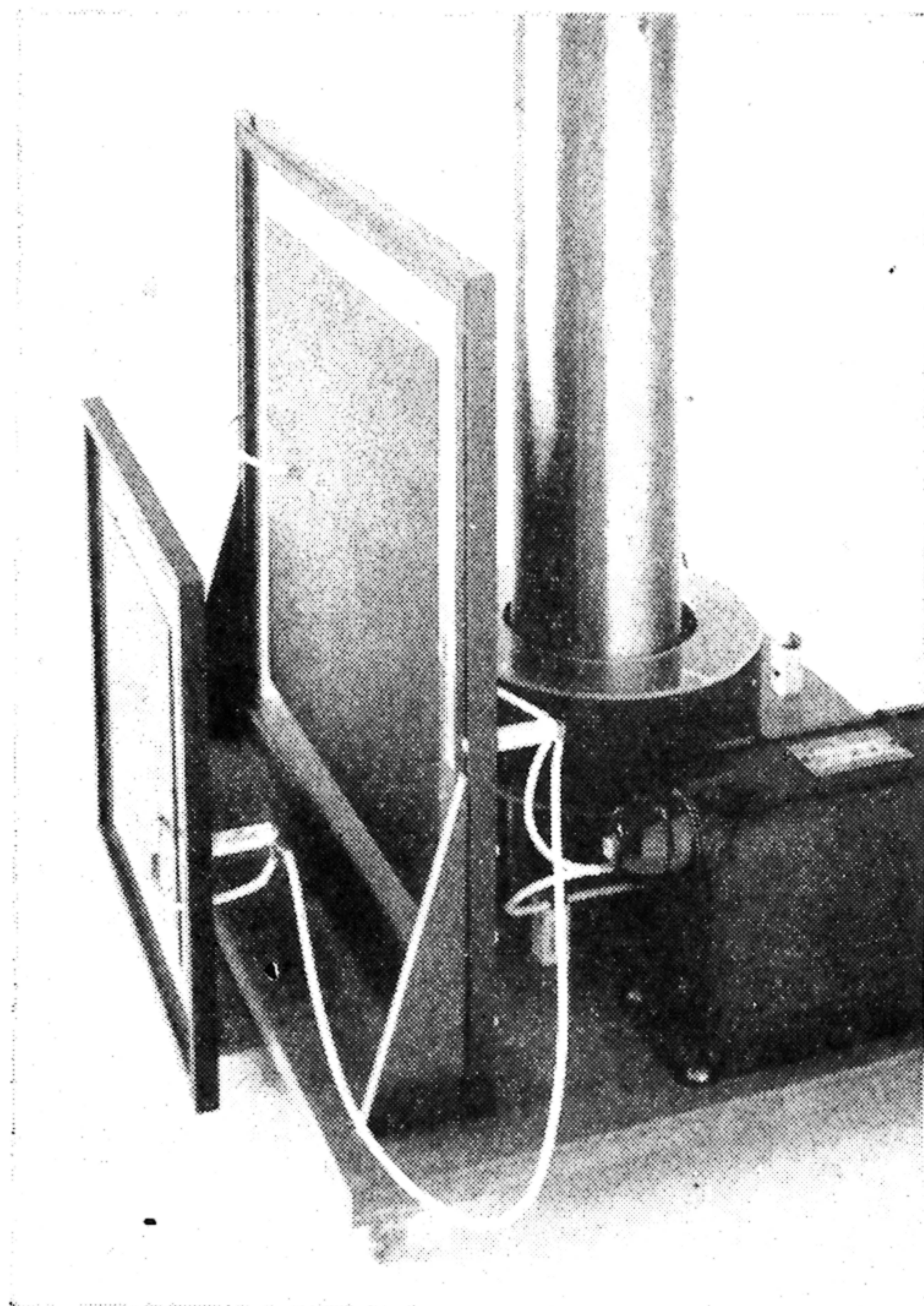

tin cemented to a $18\frac{1}{2}$ "-square piece of window glass. Although aluminum foil can be used for the capacitor plates, tin was obtained from a sheet metal shop for this purpose so that connecting leads could be soldered directly to it. If you use aluminum foil, a fairly good connection can be had by making leads of $\frac{1}{2}$ "-wide aluminum foil strips and taping them down to the electrodes.

Glass is an excellent dielectric material for this application since it has an extremely high puncture voltage and a high dielectric constant. As you will note in the drawing on page 94, a border of glass is left around the capacitor plates—this should be at least $1\frac{1}{2}$ " wide. The calculated capacity of *C1* is approximately 0.0027 μ f.

Testing and Operation. Caution! Adjustments to the Tesla coil, and specifically to the spark gap, should be made *only* when the unit is *off*. Although the output voltage of the Tesla coil may be on the order of 150,000 volts, the current capacity is only hundreds of microamps. This current can inflict a nasty shock and r.f. burns, however.

Use **EXTREME CAUTION** around the neon sign transformer. It delivers 12,000 volts at 30 ma., and this voltage could be lethal under certain conditions.

Again, be sure the plug is out when you make adjustments.

To adjust the spark gap, first open it to about 1½"; it will not fire at this point. Gradually move the electrodes together—unplugging the unit each time you adjust the gap—until the point is reached where the gap "fires."

The author's original version of "Big TC" produced an output voltage of about 100,000 volts with the single plate glass capacitor described above. To increase the output of "Big TC," it is only necessary to increase the capacity across the primary by adding one or more plate glass capacitors in parallel with *C1*. With two capacitors (both the same size as detailed on page 94), the author's prototype produced over 150,000 volts output; and with three capacitors in parallel, the output exceeded 200,000 volts. However, at such high voltage there was a tendency for insulation breakdown between coil *L2* and capacitor *C1*. This breakdown could have been overcome by making the mounting base larger and increasing the spacing between components.

The author's Mark II version of "Big TC" compromised by adding a second capacitor with half the plate area of *C1*. Except for size, this new capacitor was fabricated in exactly the same way and had a measured capacitance of 0.0014 μ f. The new capacitor was attached to the base board with a 6" x 9" piece of ⅜"-thick phenolic board. Four retaining screws held the board to the underside of the base board and four more screws affixed the phenolic to the wooden frame of the outboard capacitor. With this second capacitor (see cover photograph), the voltage output was estimated to be in the neighborhood of 130,000 volts.

The output of your Tesla coil can be estimated by drawing an arc to a metallic object attached to a long wooden handle. Slowly increase the distance between the object and the discharge terminal until the arcing stops: a 6" arc represents 100,000 volts, a 14" arc about 200,000 volts, and a 21" arc some 300,000 volts. More amazing than figures, however, are the brilliant, spectacular phenomena exhibited by high-voltage, high-frequency electricity. —30—

TELEX

FOR QUALITY

The quality of Telex headsets has become well known to hams over the last twenty-five years. Here are three Telex headsets that deliver the kind of top grade performance that hams expect from Telex—

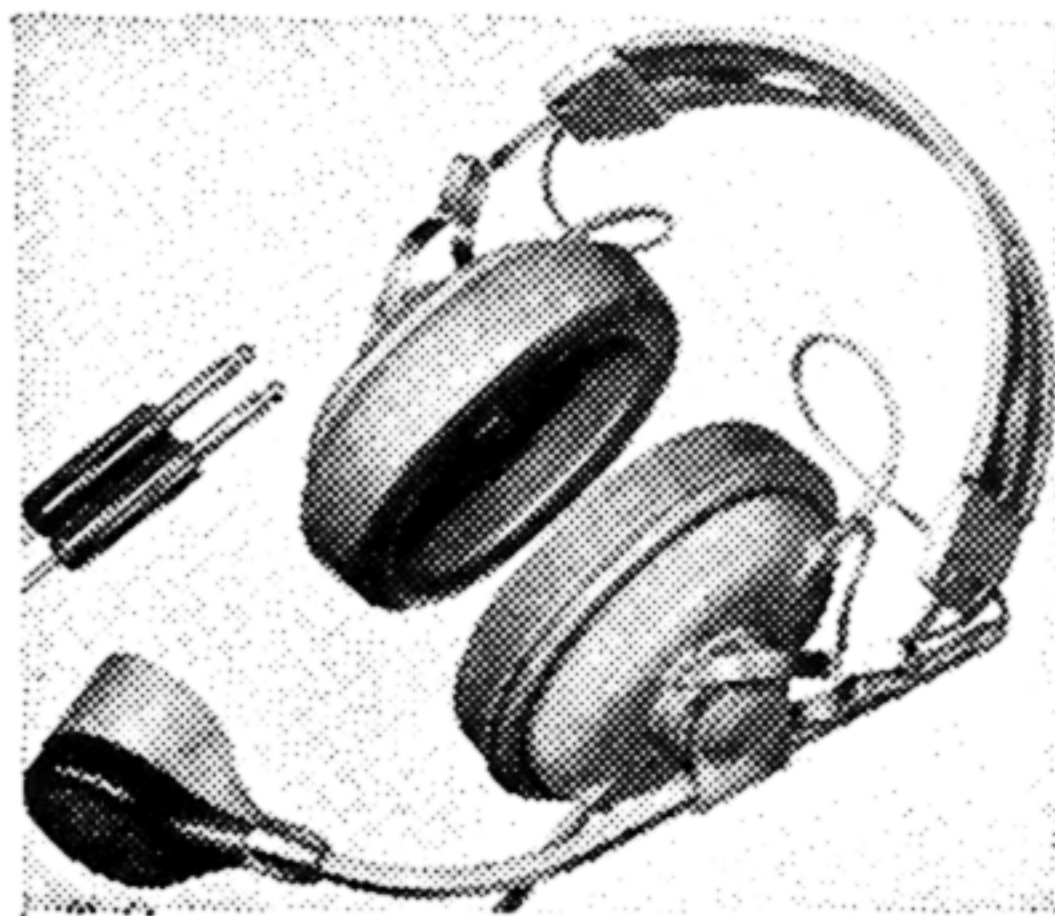

MAGNA-TWIN

For absolute maximum intelligibility under difficult QRM conditions... Super-comfort foam cushions... Rugged, moisture-proof magnetic drivers give broad response, excellent sensitivity... Sturdy construction of high impact plastic.



TELESET

Lightweight, economy version of the famous Magna-Twin... High performance, shock-proof Magna-Twin drivers... Designed especially for ham requirements.

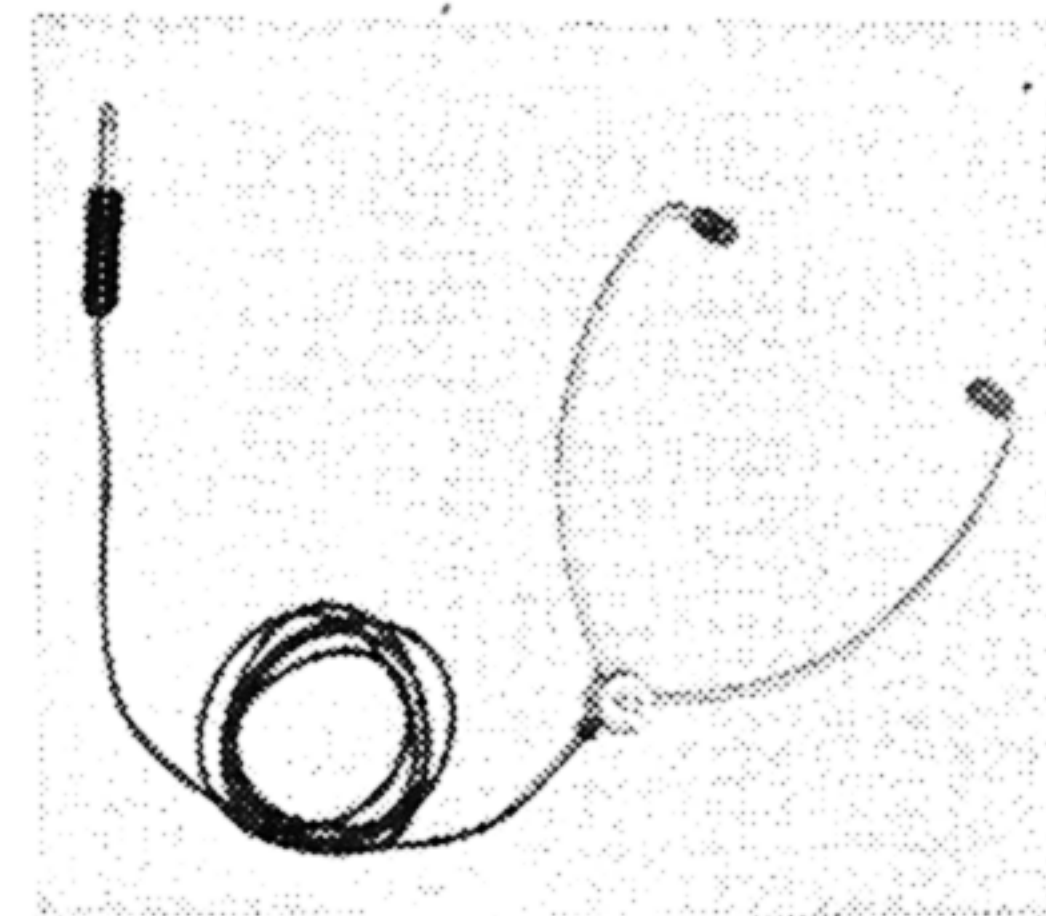

MONOSET

Feather-light at 1.2 oz... Eliminates headset fatigue... Sound from replaceable driver is fed directly into your ears through adjustable tone arms... Telex quality construction assures reliability.

Write for descriptive literature today.



TELEX/Acoustic Products
COMMUNICATIONS ACCESSORIES

Dept. EH-1 3054 Excelsior Blvd. • Minneapolis 16, Minn.

CIRCLE NO. 30 ON READER SERVICE CARD