

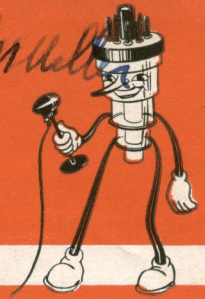

Electronic
TUBES

2/2/57 66 Allen C. Muller
Ham News



Copyright 1953, by General Electric Company

JULY-AUGUST, 1953

VOL. 8—NO. 4

The SUPER 430

a 6-Tube Converter
for Top Performance

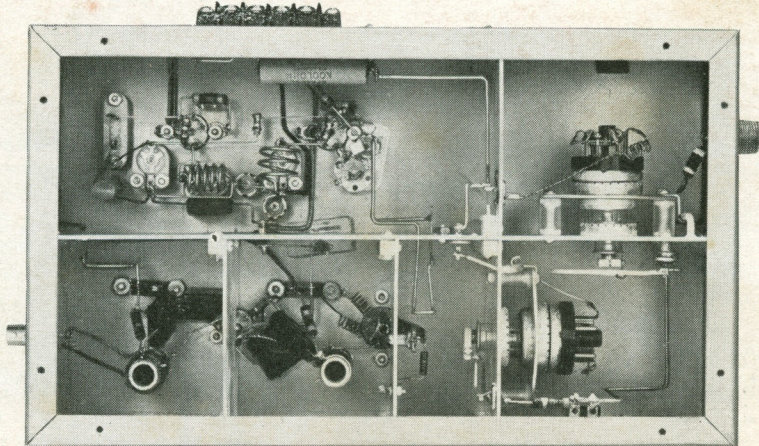
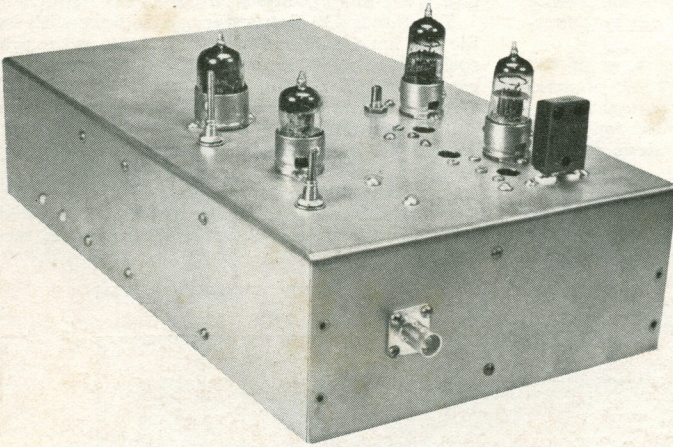

Contents

The Super 430	page 2
Sweeping the Spectrum	page 7
Rat Trap Pulse Generator	page 8

THE SUPER 430

Sometimes we take pride in putting together in an hour or so some neat little gadget which, considering its simplicity, does its job amazingly well.

Other times we take our pride in slowly building a piece of equipment which will deliver unquestionably superior performance. Such is the Super 430 Converter. It requires some care in mechanical construction, but the effort pays off handsomely in the stability needed to hold a narrow AM signal in the 420-450 mc band.

—Lighthouse Larry

Superior reception is no harder to achieve in the 420-450 mc band than it is on the lower frequencies. However, while on the lower frequencies just any old tube often is good enough, hams find their choice ever more limited as they climb higher on the frequency spectrum. At 420 mc and above the lighthouse tube stands as one of the few "bottles" that will give first-rate, dependable performance.

The Super 430 converts signals in the range of 432 to 435 mc—representing the third harmonic of most 2-meter transmitters—to intermediate frequencies between 10 and 13 mc. It is a crystal-controlled converter, and tuning is done with the communications receiver in the i-f range.

The crystal-controlled oscillator was chosen after much experimentation showed that self-excited local oscillators, even those working from a third or half of

the operating frequency, generally are not stable enough to hold a narrow band AM signal—to say nothing of a CW signal—at 432 mc. The Super 430 primarily is meant to receive signals from stabilized or crystal-controlled transmitters. Amateurs who have operated in the VHF and UHF ranges know how well a low-power stabilized narrow band signal outperforms signals of many times the power spread over several megacycles.

Hams picked up lighthouse tubes by the dozens in the surplus market a few years back, yet few of these high-frequency tubes have appeared in published ham radio circuits. The reason apparently is that the fraternity has shied away from constructing the necessary special socket. Actually, however, building this socket requires no more mechanical effort or ingenuity than hams display daily all over the world in devising new ways to put together complicated superbloopers and wave-busting finals on the lower frequencies.

The Super 430 Converter can be built with hacksaw, file and hand drill and will be as stable as the proverbial rock. The Super 430 uses two 2C40 lighthouse tubes as grounded grid r-f amplifiers, a pair of 6J6's to bring a 7-mc crystal oscillator up to the band, a 6AM4 grounded grid mixer, and a 6AK5 broad-banded i-f amplifier. A 12 x 7 x 3-inch chassis is divided into compartments as shown in Figure 1. In this picture the crystal oscillator and the 6J6 multipliers are in the large compartment at the upper left. The input connector and first r-f stage are at the upper right, and the second r-f

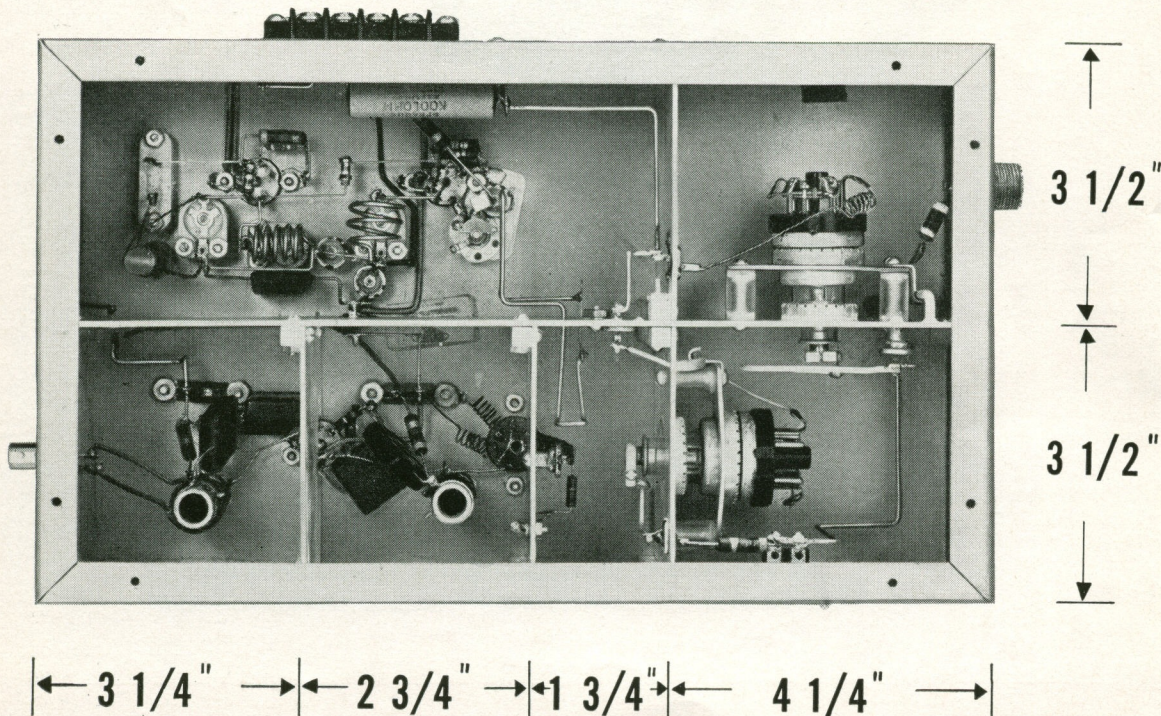

Fig. 1—The two r-f compartments and "mixing chamber" should be the same size as shown. Sizes of other compartments not critical

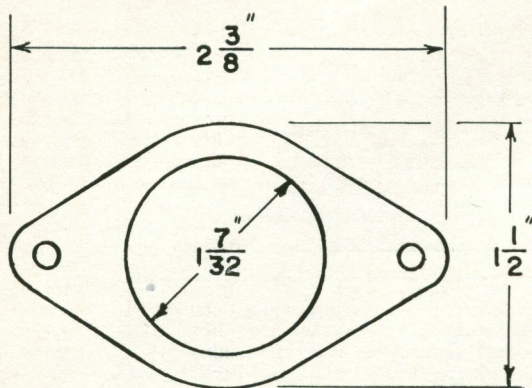

Fig. 2—Outline of brackets that hold cathode spring stock for the shell connections to the lighthouse tubes

stage is in the lower right corner. Next comes a mixing chamber where the plate tank loop of the second r-f tube, the link from the oscillator, and the cathode circuit of the 6AM4 mixer are brought into proximity. The next compartment to the left contains the remainder of the 6AM4 stage, and at the lower left corner is the 6AK5 i-f amplifier and the output connector. The compartments are made of $\frac{1}{16}$ -inch brass stock. The B-plus voltage should be between 150 and 180, and need not be regulated.

THE R-F AMPLIFIERS

For maximum performance, two stages of 2C40 r-f amplification are used, and the mountings for these tubes comprise the only unusual—though not difficult—mechanical construction.

The coaxial antenna input connector feeds through a 25-mmf condenser to the junction of the cathode line and the bracket which holds the cathode ring of the tube. This spot is found experimentally, when testing the converter, by moving the junction point up and down on the line for best performance.

The cathode and grid connectors are made from spring finger stock which is a standard part made by the Instrument Specialties Corporation.* They may be obtained ready-curved and are soldered to the inside edges of holes made in the plates as shown in the illustrations.

One-inch holes in the compartment shields accommodate the spring mounts for the grid rings of the tubes, and $1\frac{1}{32}$ -inch holes in the cathode brackets take the springs for the cathode rings. The cathode brackets (Figure 2) are set off from the compartment shields by spacers $\frac{5}{8}$ of an inch long made of $\frac{3}{8}$ -inch polystyrene rod. However, suitable $\frac{5}{8}$ -inch long ceramic spacers already tapped can be found in many pieces of surplus equipment.

In both r-f amplifiers, the cathode "coils" consist of $1\frac{3}{4}$ -inch lengths of $\frac{1}{8}$ -inch copper tubing bent as shown and spaced $\frac{5}{16}$ of an inch from the grid planes. Short strips of copper connect these "coils" to the cathode brackets as shown. Since the r-f amplifiers are operated grounded grid, the input circuits are quite broad. However, if the circuit seems to tune too low, another similar length of tubing may be placed in

parallel with the first to lower the inductance of the input circuit.

The $\frac{1}{8}$ -inch tubing permits a heater lead to be brought through to the second 2C40, while a button feed-through capacitor connects the heater lead with that of the first 2C40. The heater and cathode of the first r-f stage are kept above ground by the choke shown in Figures 3 and 7. An additional choke may be added between pin 2 and ground.

The pin connections are made by use of clips removed from an octal socket. The cathode biasing resistors are mounted on these clips as shown in the first r-f stage in Figure 3. A similar resistor, not visible in the photographs, is mounted on clips on the pins of the second r-f stage.

Since the 2C40 tubes are operated Class A and no high peak currents are required, considerable life will be added to the tube by operating at reduced filament voltage. This should be the lowest voltage at which performance and noise figure is not impaired—in most cases between 5.2 and 5.7 volts. With the filament supply used on the model shown this was accomplished by the large Koolohm resistor at the terminal strip. However, with 6.3-volt supplies, the dropping can be done with a resistance of from .5 to 1.0 ohms rated at 5 watts.

Plate connections on the model illustrated are made with clamps which were specially turned out for this converter. They are made from pieces of $\frac{1}{8}$ -inch brass, drilled with a $\frac{1}{4}$ -inch hole for the tube cap, slotted, the corners filed round, and drilled and tapped to take a 4-40 machine screw for clamping. While the clamps shown were made with machine tools, simpler ones can be fashioned with hand tools—or adjustable screw- or bolt-type clamps can be used. The objective here is to be able to secure the clamps firmly once the plate tank loops are in the proper position.

The tank loops are made of tinned No. 14 wire shaped to the approximate dimensions shown in Figure

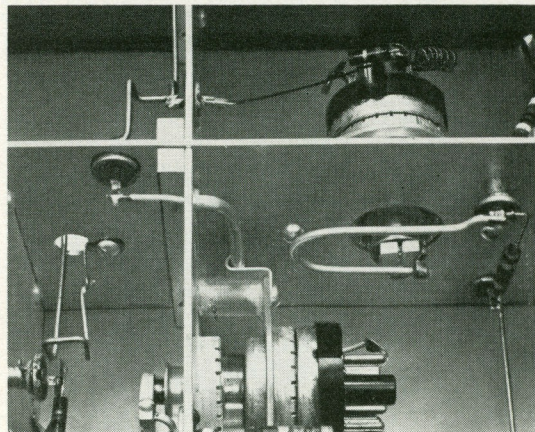
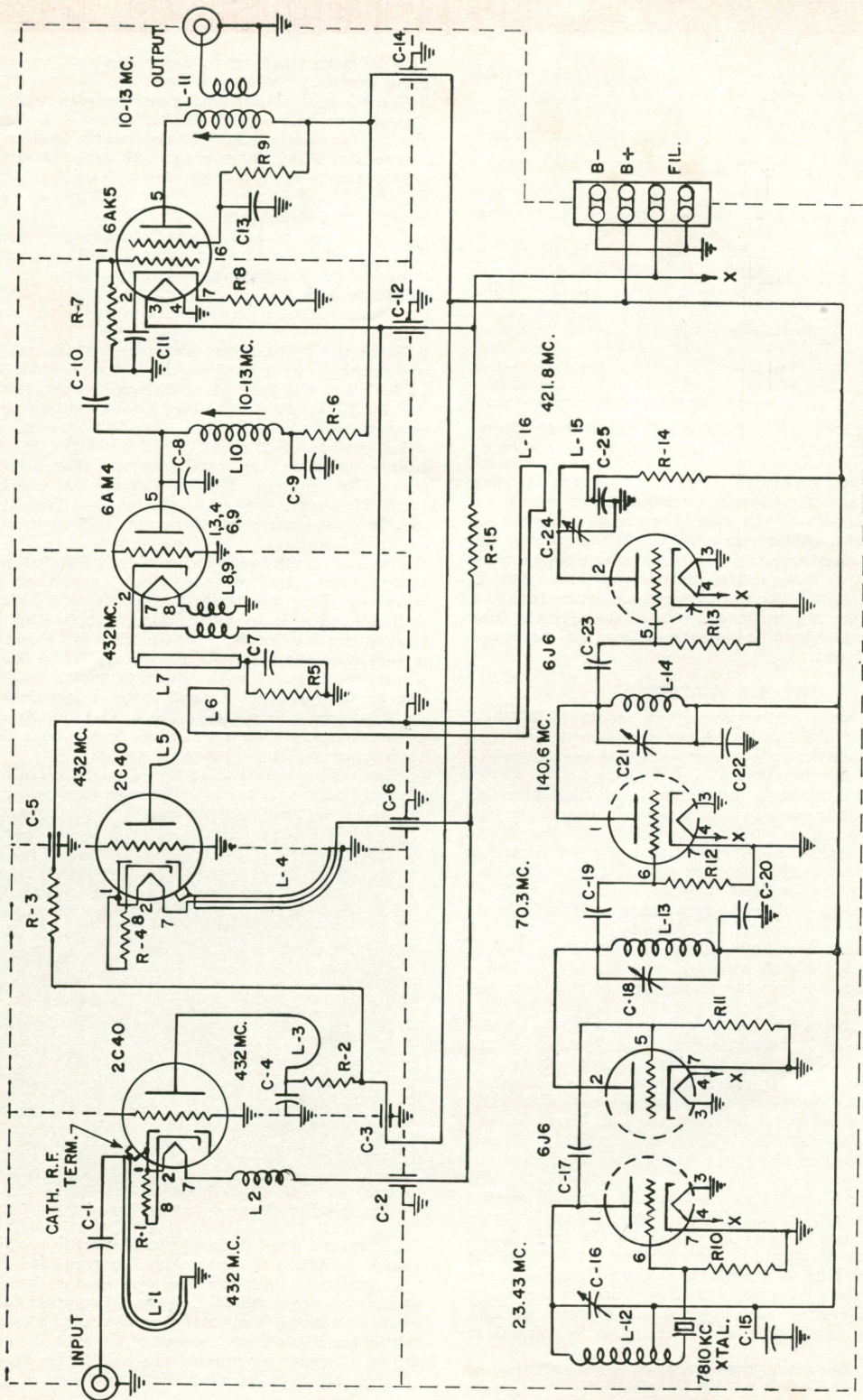

Fig. 3—Details of construction of the r-f stages

5 and spaced from $\frac{5}{16}$ to $\frac{1}{2}$ inch from the compartment shields to which the grid rings are grounded.

These plate lines are operated against ground (the grid planes of the tubes) and are bypassed at the "cold" ends with 500-mmf button condensers. Resistors decouple the loops from the rest of the circuit. The tubes are set on range by moving the anode caps up or down on the cap, thus varying the impedance of the plate

*232 Bergen Boulevard, Little Falls, N.J. The cathode connector stock number is 97-70; the grid connector 97-72.



Circuit Diagram of the Super 430. All resistors half-watt except as otherwise noted.

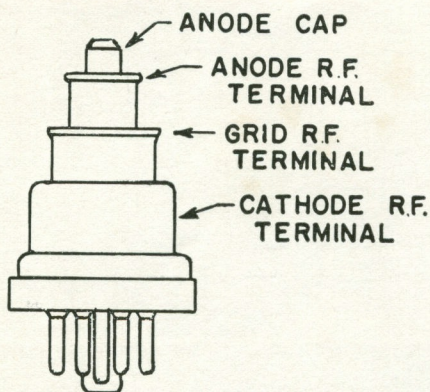

Fig. 4—Outline of the lighthouse tube

line. Coupling between first and second r-f stages is accomplished by the proximity of the first r-f amplifier's plate tank to the cathode line of the second r-f tube.

The high-voltage lead to these loops starts at the barrier-type terminal strip and runs along the chassis bend. It passes from the oscillator compartment to the first r-f compartment through a hole formed by clipping the far corner of the shield separating these compartments, and then is brought through the shield separating the two r-f compartments via a 100-mmf button feed-through capacitor.

From here a decoupling resistor brings the high voltage to a 500-mmf ceramic button by-pass stand-off condenser which acts as a terminal for the long leg of the plate tank loop of the first r-f stage. Another lead from the 100-mmf feed-through condenser continues on around the base pins of the second r-f tube to a terminal lug.

COMPONENTS

- C₁₁, C₁₇, C₁₉—25 mmf ceramic
- C₂₄, C₂₆, C₆, C₁₂, C₁₄—100 mmf button feedthrough
- C₄, C₇, C₂₀, C₂₂, C₂₅—500 mmf button stand-off
- C₅—500 mmf button feedthrough
- C₈—5 mmf silver mica
- C₉, C₁₁, C₁₃, C₁₅—.005 mfd mica or ceramic
- C₁₀—500 mmf mica or ceramic
- C₁₆, C₁₈, C₂₁—4-30 mmf trimmer (Erie TD2A-4)
- C₂₃—10 mmf ceramic
- C₂₈—1.5-5 mmf variable (Johnson No. 160-102)
- L₁, L₄—cathode loop (see text and photographs)
- L₂, L₈, L₉—RFC—6 t. No. 22 en. $\frac{3}{16}$ -inch d., $\frac{3}{8}$ -inch long
- L₃, L₇—plate loops (see text and photographs)
- L₆, L₁₅—oscillator injection link (see text and photographs)
- L₇—mixer cathode coil (see text and photographs)
- L₁₀—36 t. No. 22 en. close-wound on $\frac{1}{2}$ -inch d. slug-tuned form
- L₁₁—same as L₁₀ but with 6 t. link of insulated wire at cold end
- L₁₂—30 t. No. 22 en. close-wound on $\frac{3}{8}$ -inch polystyrene form and tapped 10 t. from crystal end
- L₁₃—5 t. No. 14 tinned, $\frac{3}{8}$ -inch i.d., $\frac{3}{8}$ -inch long
- L₁₄—3 t. No. 14 tinned, $\frac{3}{8}$ -inch i.d., $\frac{3}{8}$ -inch long
- L₁₇—U-shaped loop (see text and photographs)
- R₁, R₄, R₅—180 ohms
- R₂, R₃, R₈, R₁₄—1000 ohms
- R₇—100 ohms
- R₉—5100 ohms
- R₆—2000 ohms, 1 watt
- R₁₀—3000 ohms
- R₁₁—50,000 ohms
- R₁₂—22,000 ohms
- R₁₃—15,000 ohms
- R₁₅—(see text)

One end of the decoupling resistor of the second r-f tube is supported on this lug and the other end on the 500-mmf button feed-through condenser passing through the shield which separates the second r-f compartment from the mixing compartment. The long leg of the plate tank loop of the second 2C40 is mounted on the other end of this by-pass condenser.

THE OSCILLATOR

The first section of the first 6J6 operates on the third overtone of the 7810 kc crystal. The second section triples to approximately 70.3 mc. The second 6J6 first doubles to 140.6 mc and then triples to 421.8 mc.

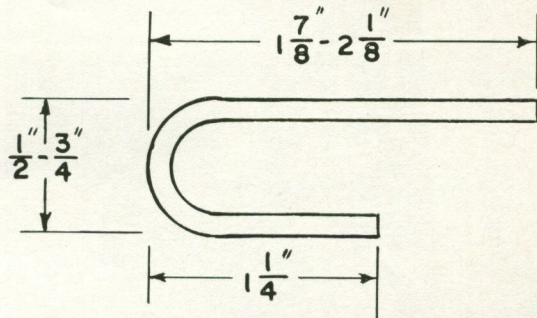

Fig. 5—Dimensions of the plate loops of the r-f stages. After pruning, the first r-f stage of the final model had the larger dimensions; the second r-f stage the smaller

These frequencies are approximate because the third overtone is not necessarily precisely three times the crystal fundamental.

While the lower frequency stages of the oscillator have been described many times in amateur literature and probably are quite familiar to amateurs who have crystal-controlled cascade receivers on 144 or 220 mc, the last tripler circuit needs some explanation and a little care in construction.

Resonance is obtained with a button ceramic stand-off condenser, a tiny Johnson variable and a small loop made of a strip of copper $\frac{1}{4}$ inch wide and $1\frac{1}{4}$ inches long. The copper is shaped into a loop with $\frac{1}{2}$ -inch

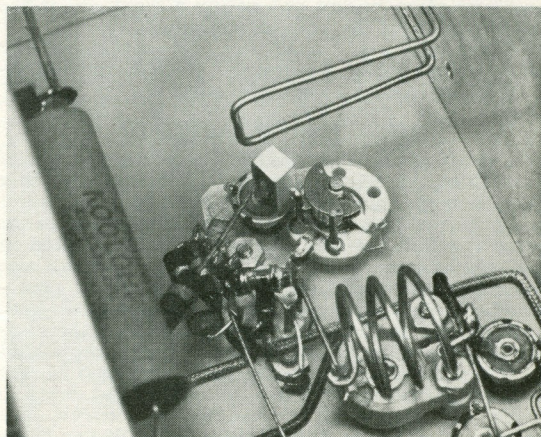

Fig. 6—Construction detail of the final stage of the oscillator

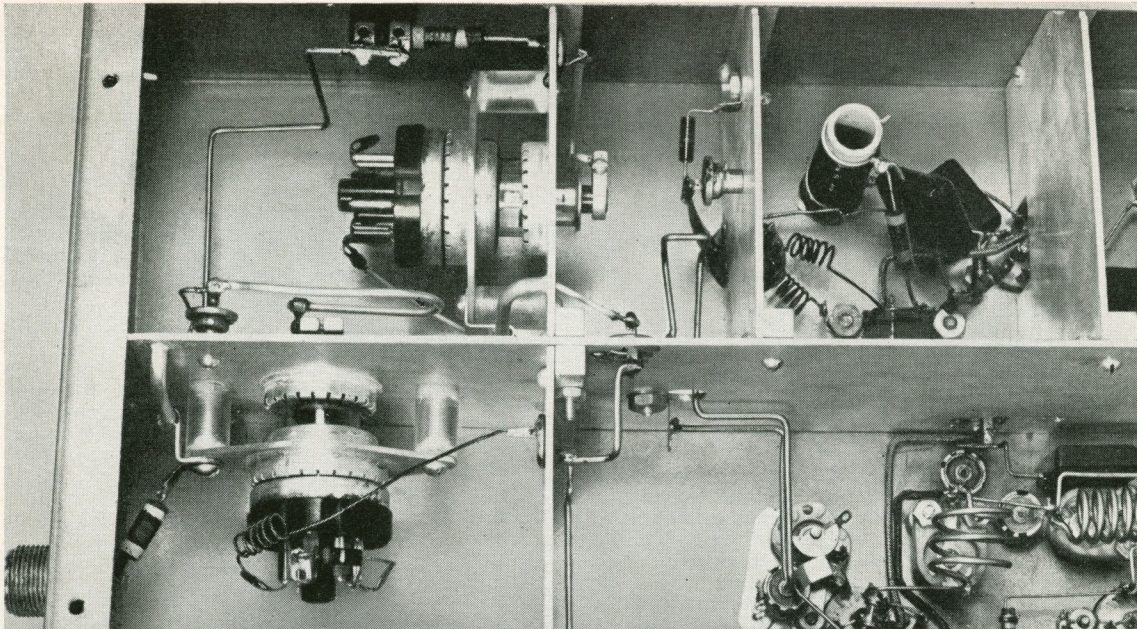

Fig. 7—Note cathode “coil” of 6AM4 in “mixing chamber” is a strip of copper extending from junction of resistor and button standoff condenser down to pin 2 of the tube

legs as shown in Figure 6. The components are carefully mounted so that one end of the loop can be soldered to one of the stator posts of the variable and the other to the lug of the button capacitor. Initial inductance can be varied by the tolerance of about $\frac{3}{16}$ of an inch possible in soldering these connections.

Note, too, that these components are all mounted on a thin copper sheet approximately $\frac{3}{4}$ inches wide and $1\frac{1}{4}$ inches long to provide the best possible common r-f ground for the circuit. Once the correct range is found by adjusting the solder connections of the loop, most 6J6 tubes will resonate with the variable condenser. Resonance can be found by metering the oscillator plate current and noting a slight dip at the proper setting of the variable condenser.

A loop of No. 14 tinned wire couples the oscillator to the 6AM4 mixer, and can be adjusted for best results while listening to a local signal.

MIXER AND I-F AMPLIFIER

The cathode “coil” of the 6AM4 consists of a strip of flashing copper $\frac{1}{4}$ inch wide and $1\frac{3}{4}$ inches long. It is located in the mixing chamber as shown in Figures 1 and 7. One end goes to pin 2 of the tube socket, and the other end to a 500-mmf button capacitor mounted on the compartment shield. A 100-ohm resistor, also mounted on this condenser and visible in the photographs of the mixing chamber, provides cathode bias.

The shield between mixing chamber and the compartment which contains the remainder of the 6AM4 circuits is made with a notch $\frac{1}{4}$ inch deep and $\frac{5}{8}$ inch long which fits over the 9-pin tube socket and serves to shield the cathode circuit from the plate circuit. The shield is placed so that three of the tube's five grid pins (1, 3 and 4) and the center shield of the tube socket can be grounded directly. The remaining two grid pins (6

and 9) are grounded to the center shield of the tube socket by a small strip of copper.

A similar shield, but with the notch $\frac{5}{8}$ of an inch deep, separates the input and output circuits of the 6AK5 i-f amplifier. Both mixer and i-f stages use slug-tuned coils resonated at 12 mc with a grid dipper and loaded with resistance.

Output is taken from the 6AK5 by a six-turn link of insulated wire which feeds to a coaxial chassis connector. A short length of RG 58U coaxial cable brings the signals to the communications receiver.

PERFORMANCE

Two of these converters were built in the process of design and development and both operated at first trial. Best performance was obtained by pruning and adjusting the various r-f circuits. As neither a suitable noise diode nor signal generator was available for testing, the adjustments were made with a specially built grid dip oscillator covering 400 to 450 mc. The Super 430 has lived up to expectations and is well worth the effort expended in careful construction.

While working with W2RMA, who designed the Super 430 Converter described in this issue of G-E HAM NEWS, we received a card from W3TEC saying he would like to hear from fellows operating in the 220- and 430-mc bands. . . . Ex-W2NX warns that use of a mineral type oil on a rope to lubricate mast pulleys (see Tricks and Topics, G-E HAM NEWS, March-April, 1953) may cause deterioration. He suggests use of a vegetable oil, pointing out that stitched canvas belting is impregnated with vegetable oil.

—Lighthouse Larry

SWEEPING *the* SPECTRUM

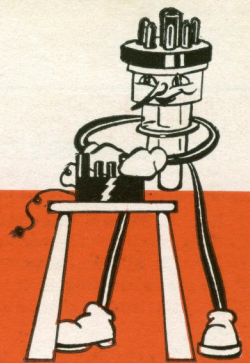

Once in a while a ham writes asking me to design a final amplifier for him—or sometimes a whole receiver. Of course, most fellows realize we can't do that, and confine their questions to specific problems—which we are glad to tackle.

But let's look a minute at what it takes to design a receiver. Assume that the receiver is to have something special about it—else why design something new? That means several weeks of development work, at the very least, to make sure the new twist is feasible. Then comes a period of building and testing which very likely will require the services of a good many people for an indefinite time. Only then are we in a position to answer the letter which asks in a sentence or so for a circuit that will do thus and so.

You may ask why not just write out a schematic and let it go at that. Well, the answer is that I simply won't risk my reputation on something that I'm not sure is going to work. I remember once talking with a photographer who is reputed to be one of the best in the business. He confided to me that he makes as many mistakes as the average commercial photographer—but no one ever sees them. For he never shows anyone a poor picture. As a result he has a first-rate reputation. And he deserves it because everything he sends out is perfect. But behind that perfection are untold hours of hard work—taking shots over and over, making print after print until he has precisely what he wants.

Incidentally, that's a success formula anyone can apply in almost any line of endeavor.



While living temporarily in a room here in Schenectady, the boss—that's the editor, W2ZBY—set up a peanut whistle on 10 meters to work the locals. He reports some of his best contacts are with his neighbor's TV sets. They read his voice and he reads their oscillators. He admits it's not an ideal two-way communication system.

I was about to bawl him out for squirting harmonics all over the street when he held up his hand and said that although neighbors complain, no Tennessee Valley Indians cavort on his landlady's picture tube—even when he runs his powerful 6AQ5 up to full 10 watts input. So when neighbors ask what is he doing to louse up their picture, he tells them that he is operating a radio station which is licensed by the federal government and transmitting on frequencies assigned by the Federal Communications Commission. Then he points out that his landlady's TV set—the nearest one to him—does not pick up the transmissions. And he suggests that something must be wrong with the complainant's TV receiver.



Well, here are four letters from fellows who want to know if they can be put on the mailing list to receive G-E HAM NEWS direct. I'll write them, as I usually do, to the effect that while the publication is designed

to be handed out through authorized G-E tube distributors, we do have a paid subscription plan for those unable to get their copies from a distributor. The cost is \$1 a year, payable by check or money order made out to General Electric and mailed to me. I admit a dollar for six copies of a small eight-page magazine is not cheap. But as a matter of fact, we lose money on the paid subscriptions and accept them only to make sure everyone who needs or wants a copy of each issue can get it.

Another letter here comes from the secretary of a radio club who wants to know if we can send him 45 copies of each issue for the members. I'm sorry that I'll have to tell him that will not be possible. He will have to get them from the nearest G-E tube distributor, or individual members will have to subscribe. However, I will be very glad to send reasonable quantities of a specific issue of G-E HAM NEWS upon request for group use.

The next seven letters in the pile are from fellows who want specific back copies and some tube data sheets.

A fellow in Texas wants to know the ratings on a G-E transformer he has acquired in a swap. That may take some time. For I have to get the answers to such questions from some G-E department or division outside my own Tube Department. That means first finding out who would be most likely to have the answer—a job in itself in a large company like this—and then cajoling them into looking it up for us. And where an obsolete piece of equipment is concerned—like many pieces of surplus—actually finding the information becomes a project in itself.

Interest in SSB is running pretty high as we get requests for information on various points all the time. Here are three right now. W2KUJ helps out with such problems in most cases.

Now the complaint department. A fellow writes that he is unable to buy a certain condenser used in a gadget described in G-E HAM NEWS a year ago. Once again, all I can say is that we try to use standard parts that are readily available. But we have no way of guaranteeing that a particular condenser will be for sale in one of the radio stores in Oshkosh a year or so from now when W8??? decides to build that equipment. Naturally, when we learn of constant difficulties in obtaining a certain make of equipment we shy away from using them in published articles, although sometimes we get fooled this way, too. For it takes sometimes a year to develop an article for G-E HAM NEWS and perhaps by the time the articles get into the radio shacks all over the country that particular shortage is over. Believe me, if we could predict what will be available at any particular location on any particular day in any particular year—well, we'd be wasting our time here.

—Lighthouse Larry

Rat Trap Pulse Generator

DR. A. HARRY SHARBAUGH, W2UKL

Once again a ham's ingenuity goes to work.

Dr. A. Harry Sharbaugh, W2UKL, is a chemist at G.E.'s modern Research Laboratory in Schenectady. But with all the advanced facilities available there—from glass blowing to hydrogen on tap in every room—what instrument does he select to test insulation? A rat trap!

Dr. Sharbaugh built the gadget shown at the right. Attached to trap is a carbon contact brush. When the trap is sprung, the brush sweeps across a stationary metal contact. For one thousandth of a second it connects a charged condenser to the insulation to be studied. An oscilloscope is used to measure the amplitude of the generated pulse.

Dr. Sharbaugh found that the trap gives dependable performance—reproducing the pulse accurately time after time. The tests are part of an over-all experiment to determine why electric charges break down various insulating materials.

Incidentally, Sharbaugh and R. L. Watters, W2RDL, also at the Research Laboratory—still hold the DX record for two-way phone communication in the 21,000–22,000 megacycle band. They were the first hams to use this band—the highest of the amateur frequencies—establishing their DX record of 800 feet on May 18, 1946.

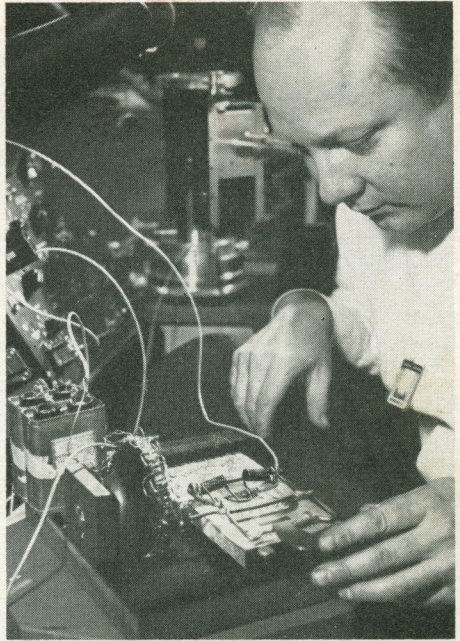

Ham News

Available **FREE** from

G-E Electronic Tube Distributors

Printed in U.S.A.

A Bi-monthly Publication

TUBE DEPARTMENT

GENERAL  ELECTRIC

Schenectady 5, N. Y.

(In Canada, Canadian General Electric Company, Ltd., Toronto, Ont.)

S. E. McCALLUM, W2ZBY—EDITOR