

**OHM'S LAW**

$$E = I \times R$$

$$R = \frac{E}{I}$$

$$I = \frac{E}{R}$$

**CONDENSERS IN SERIES**

$$C_{TOTAL} = \frac{C_1 \times C_2}{C_1 + C_2}$$

**RESISTANCES IN PARALLEL**

$$R_{TOTAL} = \frac{R_1 \times R_2}{R_1 + R_2}$$

25c [<sup>30c</sup><sub>in Canada</sub>]

W8HBN  
FEBRUARY, 1935

\$3.00  
PER YEAR  
BY SUBSCRIPTION

*Corrector for 222 Superhet*

# RADIO

ESTABLISHED 1917

## SHORT-WAVE AND EXPERIMENTAL

- IN THIS ISSUE -

A Regenerative Pre-Selector for Amateurs

The Noise-Free Two-Tube Autodyne

Simple Radiotelephones Using New Tubes

The New Browning "35" With Tobe Tuner

New Tube Data

New 802 Circuits

McElroy's Chat

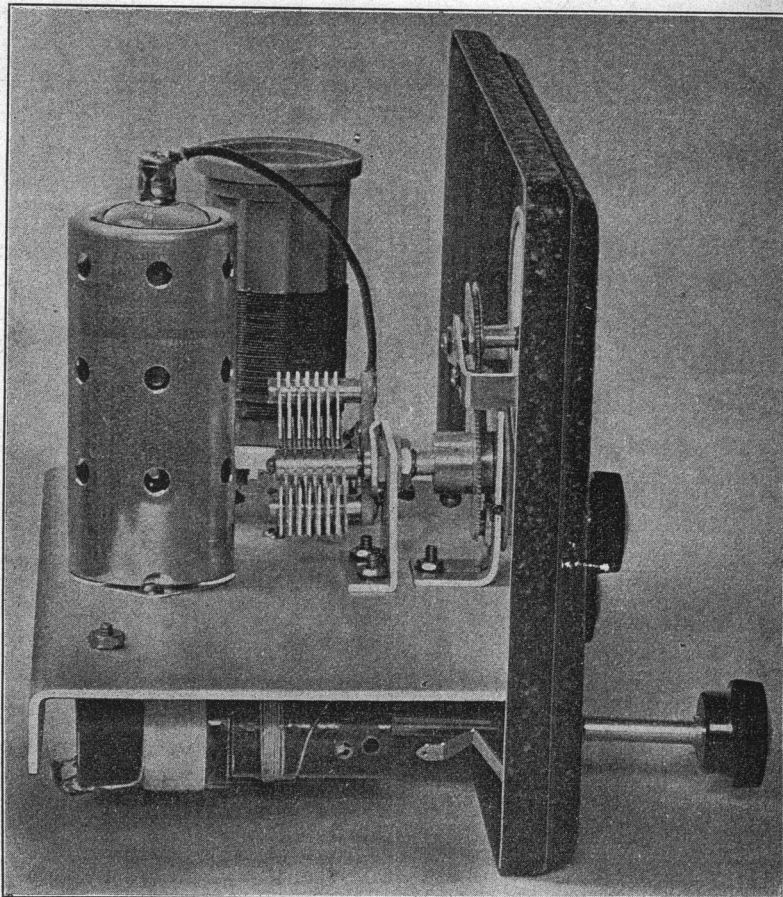

Frank C. Jones' One-Tube Regenerative Pre-Selector With Variable Antenna Coupler, Link-Coupled to the Receiver. A Highly Satisfactory R.F. Amplifier for the Amateur Bands.

FEATURE ARTICLES BY...

BYRON GOODMAN - FRANK C. JONES - ALEX G. HELLER - COL. C. FOSTER  
J. N. A. HAWKINS - T. R. McELROY - FRANK LESTER - I. A. MITCHELL

**BOTTOM VIEWS OF SOCKETS**

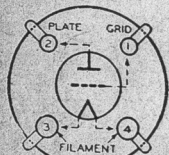

4-PRONG SOCKET

50-201-A, 45, 210, 30, 31, ETC.

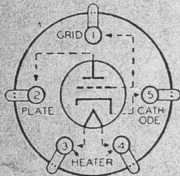

5-PRONG SOCKET

56-46-47-76-27-37

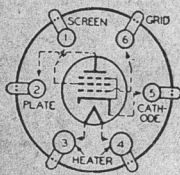

6-PRONG SOCKET

2A5-41-42-43

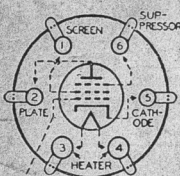

6-PRONG SOCKET

57-58-606-6D6-77-78

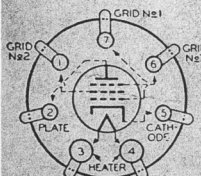

7-PRONG SOCKET 59

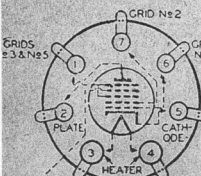

7-PRONG SOCKET

2A7-6A7

# When they sit down to *Listen*



it's the **TUBES** that clinch the sale

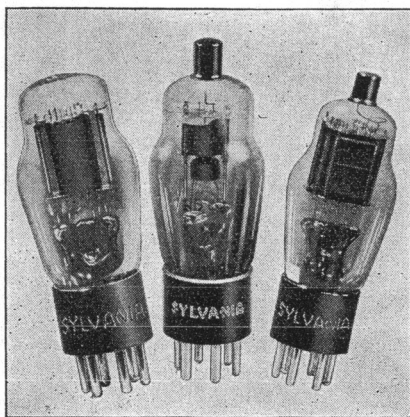

● It was the pioneering of the 6.3 volt group of tubes by Sylvania engineers that made possible the remarkable developments in the auto radio and Ac-Dc models.

Is that the reason why so many sets today are equipped with Sylvania tubes? . . . .

● Nobody needs to tell you that radio tubes made by Sylvania are famous for their faithful tone reproduction.

So why not sell, as others do,

Sylvania tubes for replacements. You know that, in workmanship and excellence of manufacture, Sylvania radio tubes are second to none.

And you will make more money by pushing Sylvania. Write for complete sales information today. Hygrade-Sylvania Corporation, Emporium, Penna.

# SYLVANIA

## THE SET-TESTED RADIO TUBE

© 1935, H. S. C.

**STILL  
AHEAD**  
in  
**Performance!**

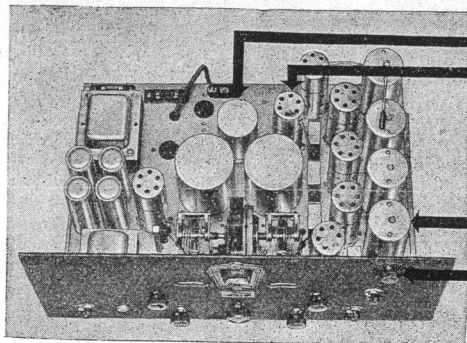

**AUTOMATIC  
VOLUME CONTROL**

*and*

**CRYSTAL  
FILTER**

**COMET "PRO"**  
*The Most Modern*  
**RECEIVER**

**T**WO years ago, the Hammarlund COMET "PRO" Superheterodyne assumed instant leadership because it met the exacting demands of professional operators and advanced amateurs, interested in both phone and code reception between 15 and 250 meters. It still holds its eminence by virtue of conspicuous performance.

The Hammarlund files bulge with praise from "PRO" users—amateurs, professionals, air and steamship lines, broadcasting networks, police and armies and navies—in every corner of the

world, who chose this amazing receiver after exhaustive competitive tests.

All models include the distinctive features of single-control band-spread tuning at all frequencies, *without extra coils*—plus all other refinements one would expect in so advanced a receiver.

The Crystal model, for CW and amateur 'phone work, employs an improved crystal circuit (*patent applied for*). This permits simultaneous parallel elimination of a strong heterodyne, while retaining the sharp, peaked characteristic of the series connection—all with substantially no loss of signal strength on pure CW. A flip of a front-panel switch instantly converts the Crystal "PRO" into the Standard "PRO", with all of its original high selectivity and sensitivity unimpaired.

**4 models**  
STANDARD  
STANDARD + A.V.C.  
CRYSTAL  
CRYSTAL + A.V.C.  
Operating on  
Battery, D.C.  
or A.C. in all  
Voltages and Cycles

**New Low-Loss COIL SETS and COIL FORMS**

**U**SERS say they get more stations, louder signals and sharper tuning with these low-priced Hammarlund Coils, (*illustrated below*) than with any other coils at any price. Perfection of "XP-53," the new Hammarlund low-loss dielectric, makes the performance of these coils the season's radio sensation. Set of four coils (4 prongs, 2 windings) for 15-270 meters, \$3.00. Set of four coils

(6 prongs, 3 windings) for 15-270 meters, \$3.75. Extra 4 or 6-prong coil for broadcast band, \$1.25 and \$1.50 respectively. 40% discount to experimenters.

No artificial coloring to cause losses in Hammarlund "XP-53" Coil Forms. Ribbed for air-spacing. Easy-grip flanges and handy "Meter-Index" inserts for recording coil ranges. Coil Forms (4 or 5 prongs), 35c each. 6-prong forms, 40c each. 40% discount to experimenters.

*Mail Coupon for New 1935 Catalog*

HAMMARLUND MANUFACTURING CO.,  
424-438 W. 33rd St., New York.

- Check here for FREE information on the Comet "Pro" Receiver.
- Check here for FREE new 1935 General Catalog.
- Check here *and attach 10c* for 16-page Hammarlund 1935 Short-Wave Manual, illustrating and describing most popular S-W circuits of past year, with schematic and picture diagrams and parts lists.

Name.....

Address.....

PR-2



# The MASTERPIECE III-X . . .

## . . . Is As Revolutionary As the Single Signal

You know what single signal code selectivity is, and of course the MASTERPIECE III-X has this selectivity, although it and the 5C are the *only* receivers made today that don't sacrifice one iota of sensitivity to get this super-selectivity—you don't lose half an R for its crystal code selectivity. But—it has the new Silver dual crystal circuit that chops out of the air exactly one phone signal at a time, and no more—that eliminates heterodynes within one kc. of the station you want. This is made possible not by the old useless "parallel crystal" scheme that made you wonder what it was ever included in receivers at all for. Not at all! Two crystals 700 cycles apart are used, one alone for code, both in parallel for phone. Thus you get a one kc. wide band, which gets intelligible speech, sans noise, sans heterodynes, sans interference as has never before been possible.

And when you want high quality broadcast, turn the crystal switch and you've got the world's finest broadcast receiver—the receiver that has elicited more enthusiastic praise from experts than all other radios put together have ever received—even good words.

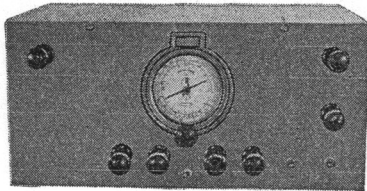

The MASTERPIECE III-X in the opinion of those who have used it in action, is the supreme receiver of all types. For it alone combines without reservation or sacrifice the unequalled and spectacular broadcast performance on all waves of the internationally famous MASTERPIECE III, with the unequalled completeness and flexibility

of the 5C, plus the new dual crystal phone selectivity that competitors will begin copying the day they read this ad.

Whatever it is you want, the MASTERPIECE III-X has it. One tuned r.f. stage so good it puts other two-r.f. supers to shame. Three air tuned i.f. stages. Perfect automatic volume control as found in no other receiver in the world—or cut out at the throw of a switch. Separate audio volume and r.f. sensitivity controls. Selectivity anything you want it to be when you want it. Tone quality that out high fidelity's high fidelity. Beauty, ruggedness, ease of operation, band spread anywhere in the range by the originator of "one dial band spread." Briefly, it has every feature found in other sets copied from it by other makers, plus dual crystal filter for real, serious, phone work. Yet it's as low in price as competition that won't even equal the 5C!

### THE 5-C IS TAKING AMATEUR RADIO BY STORM

The 5C is going into more amateur stations today than are practically all other receivers put together! But the answer is simply that it has everything. Name almost any feature you desire and the 5C has it. That's why its predecessor caused W9USA to junk the competitive receivers the World's Fair used in 1933 and get Silver's for 1934. And ask anybody that operated W9USA *how* they worked!

The 5C is built by a maker who believes in giving, and knows how to give, amateurs full value for their hard earned dollars. It has every feature of sets selling at twice its price, is easy to handle, and has the exclusive and only crystal filter circuit that gives no loss of signal strength in series operation.

This alone would deservedly make it the most popular of amateur receivers and if you don't think it's popular, just ask the QSO's who give you an R9 report what they're using and you'll probably find it's the 5C.

If you want technical dope, it's yours for a postcard—or a look at a back issue of "RADIO" or R/9. But whatever you ask "has it—," the answer is "yes." Tuned r.f., AVC that IS AVC, super-efficient crystal filter, band spread anywhere in its range of 1500 to 23,000 kc., right on the main accurately calibrated, easy to read airplane dial. But why go on—just ask your QSO's! They'll give you the lowdown.

Despite all this, the 5C is priced down where it and its competition belong. Just \$74.70 net with Raytheon tubes and Jensen speaker, or \$83.70 complete with specially aligned Xtal filter that is an Xtal filter.

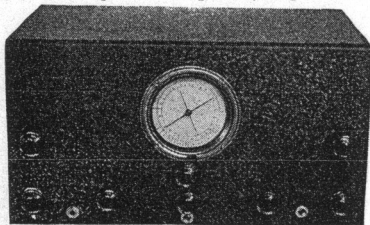

Get it from your jobber, or order direct—you can return it to us within ten days for full refund if you don't think it's a world beater. Oh yes—what other maker dares offer you receivers on such a trial basis?

**McMURDO SILVER, Inc.**  
3362B NORTH PAULINA STREET CHICAGO, U. S. A.

### THE 10-F 100 WATT PROFESSIONAL PHONE C-W TRANSMITTER

The type 10F transmitter is the improved and "prettied up" model of the now famous 10D. It is the amateur's dream come true. It provides 100 watts of crystal controlled r.f. power on crystal fundamental in any amateur band, and 60 watts on second crystal harmonic. Its phone carrier output is 25 watts modulated 100% with high fidelity broadcast station modulation, all at a cost below what you can build it for!

It employs one RK-20 screen grid r.f. pentode as a crystal controlled Tritet (electron coupled) oscillator. Modulation is affected by suppressor grid voltage variation, which is obtained from a simple two-stage audio modulator.

But read its specifications, look at its price, and get on the air with 25 watts of broadcast station voice quality or 100 watts C.W. cheaper than you can build a 100 watt telegraph transmitter alone! Order it from your dealer or direct and join the P.W.A.C. Club (Phone Worked All Countries)! If you don't believe it, ask anybody working one, W9NKH has obtained R9 phone reports out of every district—W9DDE gets R9-QSA5 phone out of every district on one installed in Waukegan, Illinois.

#### SPECIFICATIONS

**R. F. Output:** 100 watts on fundamental crystal frequency. 60 watts on crystal second harmonic. Phone carrier 25 and 15 watts respectively.

**Frequency Range:** 10, 20, 40, 80 or 160 meter amateur bands. Complete coverage with one set low loss tapped coils included.

**Tubes Needed:** 1-RK20 Oscillator, 1-RK19 Rectifier, 1-'57 Voltage Amplifier, 1-2A5 Power Amplifier, 1-80 Rectifier.

**Modulation:** Linear suppressor grid modulation variable from zero to over 100% at will. Harmonic distortion less than 5% at 100% modulation.

**Audio Frequency Range:** Modulation curve flat to 4 db. from 40 to 8000 cycles. Variable tone control provided for high audio frequency attenuation as desired.

**A. C. Modulation Hum:** Negligible.

**Phone-Telegraph Selection:** Two position toggle switch on r.f. unit selects phone or C.W. telegraph position at will.

**Antenna Tuning:** Impedance matching network with two Cardwell 365 mmf. condensers and tapped coil. Will feed any antenna.

**Meters:** None provided except on special order (mounted on r.f. unit panel). One 0-200 ma. milliammeter and, if desired, one 0-2 antenna thermoammeter are all required to check operation.

**Controls:** Oscillator plate, r.f. plate and two antenna tuning dials.

**Phone-Telegraph, send-receive, modulator on-off and power on-off switches. Screen and plate current measuring and key jacks.**

**Size:** Total height of all three 19x1/18" black crystalline steel relay rack panels 19 1/4". Supplied complete on crystalline black table rack frames.

**Power Required:** 350 watts at 105 to 125 volts, 50 to 60 cycle A.C.

**Accessories Needed:** One Billey crystal and holder, one crystal microphone, and tubes as above.

**Price Net to Amateurs, \$119.70**

Five Raytheon tubes, price \$25.23 net. Turner crystal microphone and cord. Net price to amateurs \$12.60.

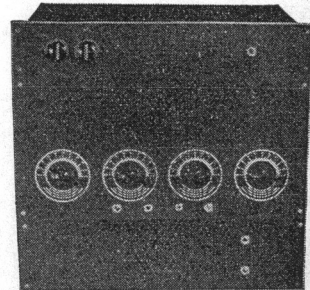

BRANCH OFFICES:  
 New York City,  
 253 W. 128th St.  
 Tel. MOument 2-2812  
 Boston,  
 J. H. Condon,  
 6 Marlboro St.  
 Chicago,  
 C. W. Nelson,  
 3618 North Bernard St.  
 Los Angeles, Calif.  
 1455 Glenville Drive.  
 Tel. CRestview 4017

# RADIO

ESTABLISHED 1917

Reg. U.S. Pat. Off.

A NATIONAL MAGAZINE - PUBLISHED MONTHLY

Publication Offices—Pacific Building, San Francisco, California

Clayton F. Bane, Editor  
 D. B. McGown, Technical Editor. Frank C. Jones, Ultra-Short-Wave-Engineering Editor.  
 Clair Foster, Amateur Activity Editor. George B. Hart, Contributing Editor.  
 H. W. Dickow, Business Manager.  
 C. C. Anderson, Engineering Draftsman

25c per copy, \$3.00 per year by subscription in the U.S. \$4.00 elsewhere. Send subscriptions to the San Francisco office. Entered as second class matter at the Post Office at San Francisco, California, under the Act of March 3rd, 1879.

Vol. 17

FEBRUARY, 1935

No. 2

## RADIOTORIAL COMMENT

MEMBERS of Congress—the men charged with the duty of seeing that all citizens of the United States get a square deal—cannot act in behalf of the 46,000 radio amateurs unless the amateurs themselves inform their senators and representatives. The amateurs—citizens who own and operate non-commercial transmitting stations—have never received a square deal in the partitioning of the air among various interests. That is because the voice of the amateur is unknown to the ONLY agency of the government that will give heed to his claims, the Congress.



● This was true before the days of international radiotelegraph conventions. And since these gatherings—beginning with that of 1927—became the battleground of self-seeking commercial interests and foreigners the amateur has fared still worse, for now it is foreigners who dictate how little of America's air American amateurs may use. Perhaps the amateurs are to blame for this situation, too, for if they had not discovered and developed the far-reaching short waves there would have been no short waves for commercial interests to covet and, therefore, small need for international conventions for allocating the short waves.

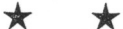

● However that may be, it remains that through the unacquaintedness of Congress with the needs and rights of a great body of American citizens the fortunes of those citizens are now dictated largely by foreigners, those incorrigible chiselers who have only one use for the United States. And when it isn't the grasping foreigners who are after the scalp of the American amateur it is the American commercial interests who are ever scheming to limit his space on the air and prescribe his usefulness to the government and to the public.



● Before 1927 it was the American commercial interests that took from the amateur most of his air channels. "Authorized representatives" of the amateurs GAVE it to the commercial interests. So we are told in a court record in Washington. Then the convention of 1927 cut two-thirds from the little that these "representatives" hadn't already given away. Of the results of the 1927 convention the same "representatives" reported to the amateur body:

*"These privileges in most respects are entirely adequate. We have achieved a great victory."*

Which gives a clear picture of what the amateur "representatives" think is good enough for amateurs.

● Laboring under the severe handicap of overcrowding, the amateurs still maintained their right to serve the people with a free message service with all countries which did not prohibit their amateurs from handling such messages. Then came the Madrid convention of 1932. Again the commercials and the foreigners took a bite out of amateur radio by flatly prohibiting the international exchange of messages for the public. And again these same amateur "representatives" actively worked for the ratification of this latest encroachment on the rights of the American amateurs and the public that benefited by the free message service.



● And all this systematic usurpment of the rights of a large body of American citizens was made possible because the amateurs themselves had failed to enlighten their senators and representatives in Congress. There is not a congressman in the nation who will not gladly aid the amateurs once he is informed of the conditions under which they are now forced to operate.



● Let us turn back the wheel of time. 1917. WAR! Millions of men called to arms. Thousands of men needed to conduct the communications of the forces of the United States. Where were the men to build and operate the radio land-stations, the telegraph sets in the field, the radio sets hurriedly installed on ships that were commandeered or built almost overnight? That is what Uncle Sam wished to know in 1917. And, for all he got 3,600 trained radio operators and technicians from the ranks of the amateurs, he still needed many more. That is why he was forced to TRAIN thousands of radio men to hold important posts in the activity that is absolutely vital in times of war—Communications.



● Men, often possessing only a meagre knowledge of radio or communications, were commissioned and placed in charge of radio training camps. Men were hurriedly put through a course of training and thousands of half-baked operators and station mechanics were sent into the field and upon the oceans to man radio equipment. Those of us who remember 1917, 1918 and 1919 recall the exasperations and costly delays in trying to effect communication with prematurely-hatched radio men who had been assigned to important posts. Competent men vowed then that this experience should never happen again. And it won't—provided only the present body of amateur station owners is given enough space on the air to keep them interested in the art of radio communication,

and provided they are not discouraged by being forced to comply with a host of restrictive measures meted out by foreigners and commercial interests. Without adequate communications facilities the greatest army and navy in the world is helpless. These foreigners don't WANT the United States prepared.



● So nation-wide action is under way to the end that every senator, every representative in Congress and the President himself shall hear, and shall CONTINUE to hear the amateurs' message and comprehend its significance.

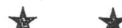

### Same Old Story

SOME of you have heard this story before. We repeat it once every five years or so. "RADIO" is published in San Francisco, but only about 10 per cent of its circulation is on the Pacific Coast. Most of the magazines are shipped to the mid-west and further east, where the sale is heavy, simply because more people reside in those sectors of the nation. About 12 years ago, "RADIO" had more subscribers in McKeesport, Pennsylvania, than in any other city.

For some unaccountable reason, many of the biggest scoops in radio have originated on the Coast. Let's take stock. First we had Doctor DeForest and his audion bulb at the Panama Pacific International Exposition in 1915. Then came Elmer T. Cunningham of San Francisco with his Audiotron. We put the first practical radio-telephone station into commission in the California theatre. Along came Gerald M. Best from the A. T. & T. Co. He joined the staff of "RADIO" as its technical editor, developed the 45,000 cycle Best Superheterodyne, of which 1,200,000 were built. The superheterodyne and "RADIO" were synonymous.

Later came the first dynamic speaker by Magnavox. Then the radio compass by Kolster. The Infradyne, by Sargent. Super-regeneration on 5 meters by Frank C. Jones of "RADIO." Sound pictures from Hollywood. Cathode-ray television by Philo T. Farnsworth. The gas-free transmitting tubes by Heintz and Kaufman, and by Eitel-McCullough. The cold-cathode electron multiplier.

Much of the big-time radio news is made in San Francisco, even though the newsmakers eventually fold their tents and quietly trek to the East. There is nothing more stale than stale news, so "RADIO" stays in San Francisco simply because a lot of irons are now in the fire and something hot is liable to pop at any old time.

# The Noise-Free Autodyne

A Two-Tube Receiver That Goes Down to 10 Meters - Has Numerous Improvements

By BYRON GOODMAN, W6CAL

ABOUT the time the 222 tube was introduced, an article appeared\* describing a completely shielded receiver, for which the writer made great claims. The shielding was so good that, with antenna disconnected, a 50-watt transmitter five feet away was about R5. This sounded like a good idea at the time, and has always been in the back of the mind of this writer. It was therefore decided that the receiver should be well-shielded, with the ideal a receiver that would pick up nothing with the antenna off. The set was to be used for CW, so no reason for including a RF stage could be seen. Previous experience with detectors capacitively coupled to the antenna had brought out many disadvantages to this system, and in casting about for a better means of antenna coupling, link coupling was considered, and the more it was considered, the better it looked. To eliminate the last vestige of capacity coupling, a Faraday screen would be used. The writer's pet band is 28 MC, so the receiver must work on this frequency, and work well.

The circuit is conventional in every respect. It utilizes a 57 detector in the familiar electron-coupled circuit which has proven so simple to make oscillate, especially at the higher frequencies. The Hartley type of oscillator is used, but its variation as used in the "Gainer" could also be used in this receiver, and probably adapts itself a little better to coil adjustment. Regeneration is controlled by varying the screen-grid voltage with a potentiometer, which gets its voltage from across the voltage divider incorporated in the set. There is a RF filter in the plate lead from the detector, as a precaution against RF in the audio impedance. The audio stage is a 56 type tube, used because of its high gain, although a 27 could be used. Everything is conventional and standard practice, except the filtering of the phone and power leads, and the link coupling to the antenna.

With a good idea of what was desired, and a nebulous idea of how to achieve it, the receiver was built. The panel was made of

aluminum, 7½-in. deep. The aluminum sub-panel was made by bending over the front and back of another piece of aluminum, these sides being 2-in. deep. A bottom was closely fitted, and fastened by tapping holes in the ¼-in. dural corner posts. A top was also closely fitted and it merely rests on the corner posts. The photographs show this more clearly than words. The National drum dial was used because it lent itself well to making a compact set, and has very smooth

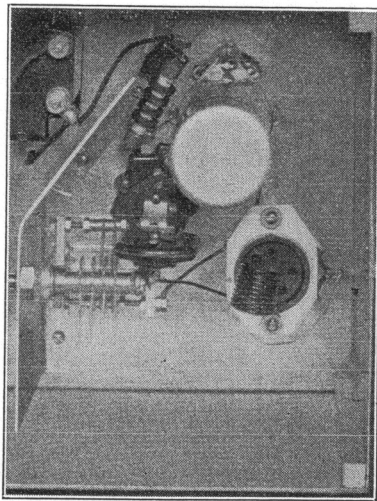

Close-up of the 10-Meter Coil.

vernier action. The National SEU type condenser was selected for tuning because of its good insulation and complete freedom from noise—important factors on the higher frequencies. The tuning condenser was mounted on an aluminum bracket which served to rigidly support it and also to shield the audio impedance from the detector stage, found necessary to completely eliminate the last trace of fringe howl. The five-prong Isolantite socket that takes the various plug-in coils was mounted as close as possible to the tuning condenser in order to facilitate short leads, but far enough away from both the condenser and the shielding so that no losses would be introduced into the coil by having metal in the field. Slightly over one coil diameter is sufficient. The coil socket and tube socket were mounted above the subpanel on the mounting bushings supplied with the sockets so that all RF wiring would be as short and direct as possible. The grid condenser and leak were mounted directly on the tuning condenser so that the lead to the grid of the detector tube would be short. That all of this care about short leads is not poppycock is shown by the ease with which the set oscillates on 28 MC, and the fact that all coils required many more turns than is common practice. This high L-C ratio makes for sensitivity, as will be discussed later. The plate filter was mounted above the subpanel to keep leads short and RF from under the subpanel.

Under the subpanel the wiring and arrangement is completely conventional, with the possible exception of the RF filters and the use of so many by-pass condensers. Note,

for example, that the screen grid of the detector tube is by-passed twice—once right at the socket by C6, and again by a .5 mfd condenser across the regeneration control. This latter condenser is used mainly to eliminate any noise that might be caused by a poor potentiometer. Every effort was made to keep RF where it belonged, and to give it short and direct return paths. The condensers and resistors under the subpanel were placed where convenient, and the only thing worthy of mention is the two RF filters. Realizing that a great deal of RF is present in the phone cords, as any owner of a two-tube receiver can demonstrate by running his hand over the phone cord and noticing the change in beat note, it was decided to filter these leads. A simple filter consisting of two .00025 mfd condensers and two RF chokes was used, and the condensers, with the phone jack, were included in their own special shield can, as can be seen. The other shield can contains the power supply RF filter, which merely consists of a pi section filter of two .01 mfd condensers and a RF choke. The two shield cans are easily made of pieces of aluminum bent to form three sides of the box, and another piece with the edges bent over so as to fit snugly over the can. The utter simplicity of construction amazed the author when he built it, and brought forth the usual "Why didn't I think of that before?"

Coils, except the one for 28 MC, were wound on National forms, and the turns data is given in the table. It may as well be confessed here that the small tuning condenser does not give full coverage on the 3.5 MC band, but the receiver was primarily built for the higher frequencies, so this is not important. It does cover from 3.5 to 3.9 MC though, and we don't think anyone would use a receiver of this type for the crowded 75 meter phone band anyway. Proper band spreading was achieved by using the usual padding condenser across the tuning condenser. "But", you say, "there is no condenser shown in the photographs or wiring diagram." Right! It was decided that each coil would contain its own padding condenser, but we didn't like the idea of sticking all that metal right in the field of the

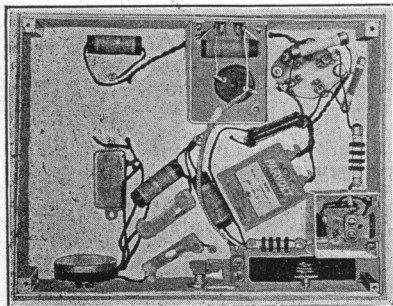

Under-chassis view. Note the separate small shielding boxes in which the noise-filter parts are housed. These boxes are made of aluminum and secured to the chassis with machine screws. The boxes must be covered with aluminum top pieces, or lids. The lids were removed for the purpose of photographing the parts inside the small shield boxes. In the shield box at the rear of the chassis the filament and plate power filter parts are located (three .01 condensers, one of them non-inductive, and an R.F. choke). The other shield box houses the headphone-circuit by-pass condensers. These condensers keep hum and house power-line noise out the receiver, which would otherwise be picked-up by the phone cord. Hand-capacity is also minimized; furthermore, monitoring the transmitter is made possible.

\* R. B. Bourne, "Getting the Most Out of the UX-222", QST, December, 1927, page 35.

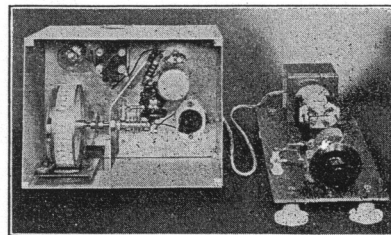

Looking into the receiver from the top. Note how the aluminum shield partition is bent. This shield minimizes interaction and fringe bow.

coil. A piece of No. 28 enameled wire was soldered to the ground side of the coil, right in the coil itself, and this was wrapped around the lead that led up to the grid end of the coil. This permitted accurate spotting of each coil right into the band, and the more turns, the more capacity and consequently the more bandspread. When the coil has once been adjusted, the extra wire is cut off,

and the coil is adjusted once and for all. And even a careful observer has difficulty spotting the padding condenser! Right here let us make a plea for a little experimentation by set-builders. If your coil doesn't hit the band, even though you built the coil "just like the book", fool around a bit. By cutting and pruning you may end up with a coil twice as good as the writer had.

The antenna coupling was the writer's pride and joy, until he found that many people were using it, but they all arrived at it independently, so no one gets full credit. It is link coupling, and has so many advantages that we would like to take time out and dwell on them. To our knowledge, no one operates his transmitter with an untuned antenna, but alas, all too many neglect to tune their antennas for receiving. Many amateurs have advocated it for years, but the ham-shacks that this writer has visited have shown a conspicuous lack of tuned receiving antennas. When you tune the antenna and couple it up to the detector, a terrible amount of interlock is present, and this may be part of the story. A RF stage isolates this trouble, but what about the fellow with the two tubes? Link coupling reduces this interlock and delivers maximum signal from the antenna. It would be nice if we could state here that the interlock was completely eliminated, but this lad's untruths are confined to statements about input to final amplifiers. Link coupling was therefore incorporated in the receiver, the link running through flexible shielding (we wanted to use aluminum tubing but it rather lacks flexibility) to a copper box which contains the two-turn coupling loop, wound on a tube base and almost smack up against the Faraday screen. A two-inch hole in the box is the only opening, and is covered by the screen (described later). Therefore, the only way any signal can get into the receiver is through the screen, and this has to be by magnetic coupling, which is obtained from the tuned antenna circuit. The Faraday screen was made by winding a layer of paper over a scrap piece of aluminum, winding No. 22 enameled wire around this (spacing the turns with string). The ends were fastened, the string unwound, and the wire fastened to the paper by painting with Fifteen-Cent Store fingernail polish (crimson was used, but some prefer rose-colored, and there is a movement afoot to use just plain collodion if you are embarrassed when buying nail polish from cynical Woolworth employees). After several coats had been applied and dried, one edge was cut and the paper and winding removed from the form, leaving two flat windings. One of these was trimmed up and the wire along one edge scraped and soldered to a common wire. Any method of construction is satisfactory, the result desired being an effective comb of wire, with the wires separated approximately their own diameter, fastened together at one end, and open at the other. The screen was mounted on the inside of the copper box, and the common wire soldered to the box. The antenna coil is mounted in a socket, to facilitate band-changing, and mounted on a board with the antenna tuning condenser. To loosen the coupling (a very convenient volume control, by the way) the board is moved away from the link housing. The system works well with any length wire as an antenna, functioning the same as an end-fed antenna. Doublets are still better, and have the advantage of no hand capacity.

A word about the power supply. The leads from the power supply are run through shielded cable and terminate in a four-prong plug which plugs into the wafer socket on the back of the set. The shielding cuts down pickup by the power cable, giving the filter in the set a little less work to do. There

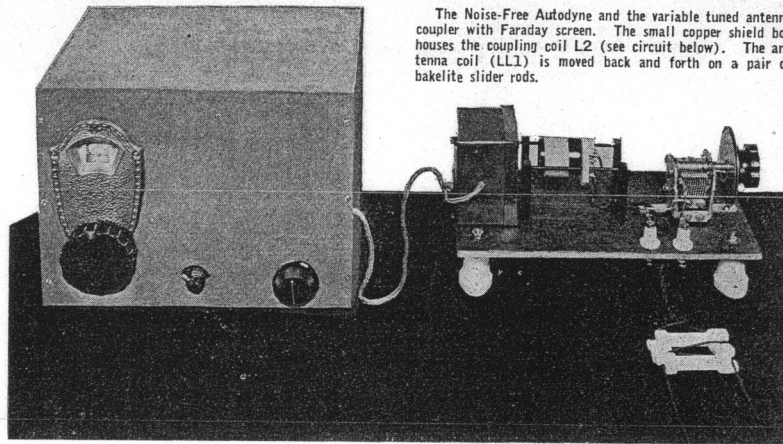

The Noise-Free Autodyne and the variable tuned antenna coupler with Faraday screen. The small copper shield box houses the coupling coil L2 (see circuit below). The antenna coil (LL1) is moved back and forth on a pair of bakelite slider rods.

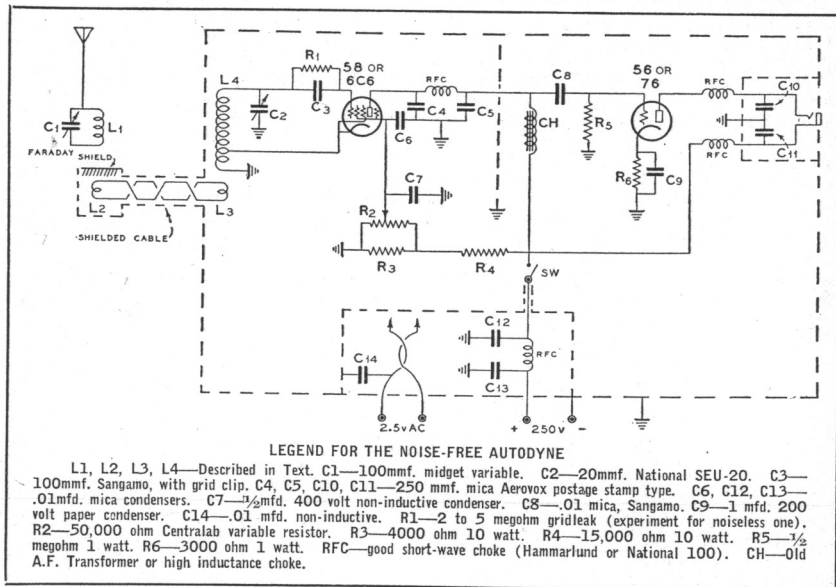

is no reason for not operating the tubes in the set at 250 or 275 volts, and you will be surprised at the volume of the two-tube receiver. It is said that the signal comes up faster than the noise with increased plate voltage, and while we don't know the technical reason for this, we are certain that it comes up just as fast. One thing to remember, though, and a point that is often overlooked: run the heaters at full rated voltage, measured at the socket, and no noise from shot effect will be encountered. This is because the cathode will be surrounded by a cloud of electrons so thick that irregularities in emission cannot manifest themselves as irregularities in plate current. At high plate voltages, the audio amplifier plate current runs a little high, so to keep this out of the phones, an external output transformer was used, thereby eliminating DC from the phones. A condenser and choke could also be used to couple the output.

During the period of construction of the receiver, big dreams of the low noise level, perfection of shielding, sensitivity, etc., ran rampant through the builder's mind. Upon testing the receiver, low noise level was found to be quite in evidence, the set being by far the quietest ever heard. Few signals were too weak to copy, and we know that better ears than ours would have copied them solid. With a thumping heart we removed the antenna coil and turned on the transmitter. It had been hoped that we would be unable to hear the transmitter at all, or at least that it would be just audible. Such was not the

case. We could tune in the transmitter and it would block the receiver quite nicely but—for only about 15 KC either side of the transmitter frequency! We later found that we could couple up the receiving antenna, leave the buffer stages running, and work break-in with stations about 100 KC from our own frequency. Try that with your ordinary two-tuber! We had to admit that our shielding and filtering had not been as complete as we had planned, but certainly it was good enough to show the merits of good shielding. Completely air-tight joints and

(Continued on Page 23)

#### COIL DATA:

- 3.5 MC—46 turns No. 30 enameled, close wound, tapped  $1\frac{1}{2}$  turns up.
- 7 MC—23 turns No. 18 enameled, spaced diameter of wire, tapped  $\frac{7}{8}$  turns up.
- 14 MC—11 turns No. 18 enameled, spaced  $1\frac{1}{2}$  diameters, tapped  $\frac{3}{4}$  turns up.
- (Above coils wound on National five-prong coil forms).
- 28 MC—9 turns No. 14 enameled wound  $\frac{3}{4}$ -in. diameter on air, tapped  $1\frac{1}{2}$  turns up. Turns spaced about  $\frac{1}{2}$  diameter.

Each link coupling loop consists of two turns interwound between the two bottom turns of each coil.

# A Regenerative Pre-Selector With Variable Antenna Coupling

By FRANK C. JONES

● Many superheterodyne receivers which have no radio frequency amplification ahead of the first detector have been built for or by amateurs. This usually means a high ratio of noise to signal and has given the superheterodyne receivers a reputation of being excessively noisy.

Radio frequency amplification can be obtained either by the use of one or two RF stages or by means of regeneration in the first detector. The main purpose is to amplify the signal, as much as practically possible, before heterodyning it to the IF frequency in the plate circuit of the first detector. This invariably gives a better signal to noise ratio and the really weak signals are made readable through the receiver noise.

The pre-selector here described consists of a single stage of RF amplification to be used ahead of any short-wave superheterodyne receiver. By the use of variable antenna coupling and cathode regeneration, this single stage can be made equivalent to the usual two stage RF pre-selector. It not only increases the signal to noise ratio but also reduces image interference.

The variable antenna coupling is obtained by means of a sliding coil and it is not necessary to change this part of the coil circuit for the different amateur bands. An efficient plug-in coil is used as the tuned circuit inductance in order to obtain maximum efficiency and correct cathode tap for each band. Regeneration is controlled by means of a 50,000 ohm potentiometer which varies the screen voltage. The screen-grid series resistor of 5,000 ohms, shown in the circuit diagram, tends to prevent the regeneration control from introducing noise as the latter is varied. The plate voltage is fed through a small Hammarlund multi-section RF choke which is effective over all of the amateur bands.

The plate circuit is connected through a coupling condenser to the receiver so this can connect to the antenna post on the main receiver, or this lead can be twisted around the first detector grid lead a few times to obtain capacity coupling. In the latter case, the detector trimmer condenser should be re-set for best results.

The cathode circuit uses a 1,000 ohm resistor for self-bias. This is by-passed by means of an .01 mfd. condenser. Normally from 400 to 600 ohms is sufficient for cathode

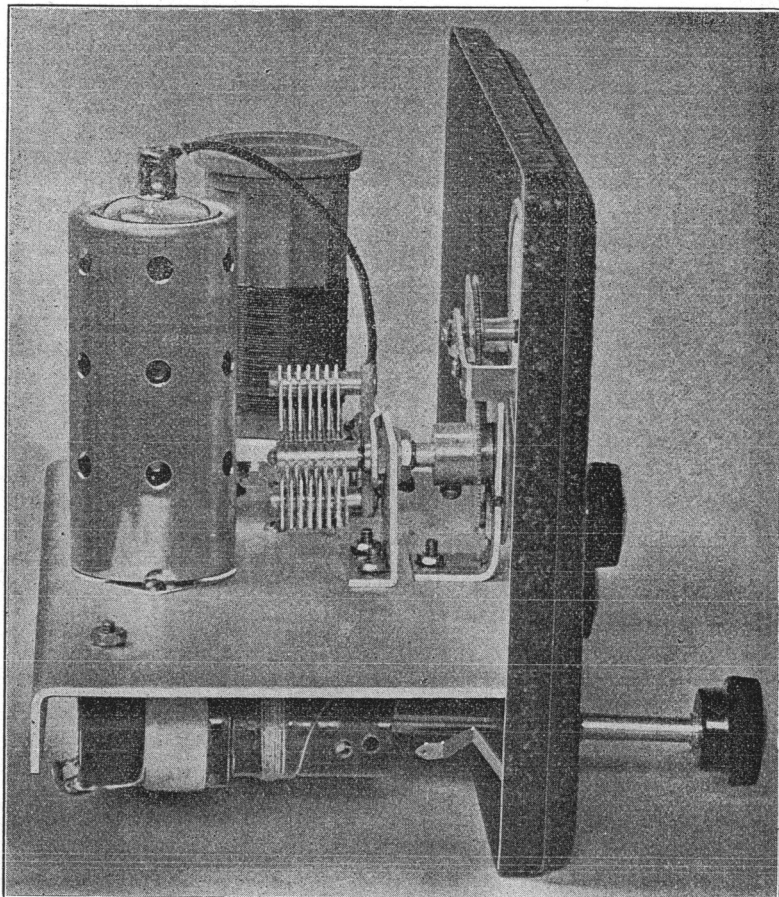

The Completed Pre-Selector, showing proper location for variable antenna coupler.

bias, but with variable screen voltage and regeneration, a value of 1,000 ohms seems to be desirable. This higher value also tends to prevent strong local signals from causing cross-talk interference in this stage. Many superhets suffer from cross-talk in either the first detector or RF stage. This cross-talk is especially bothersome in the broadcast range on some all-wave sets. This cross-talk usually is in the form of numerous whistles on top of broadcast station channels where no heterodyne interference should be had. On short wave channels it takes the form of whistles, or mush, from local stations near the frequency to which the set is tuned.

The regeneration is affected slightly by the plate circuit load, so a little juggling of the cathode tap and the coupling to the receiver may be necessary in some cases. The RF tube will slide into oscillation smoothly when the pre-selector is functioning properly. The point just below oscillation gives the greatest gain and selectivity.

The antenna coupler is made of two pieces of bakelite tubing, each 1½ inches long. The larger one is 1⅛-in. outside diameter and the smaller one ⅞-in. diameter, so the latter with its winding of 8 turns will slide

readily inside of the other tube. The larger tube has 20 turns of No. 28 DSC wire, close wound, and this should connect to a doublet antenna for maximum outside noise reduction. This link coupling system reduces antenna capacitive coupling to a very small value, and thus a balanced doublet antenna with transposed or twisted-pair lead-in will work

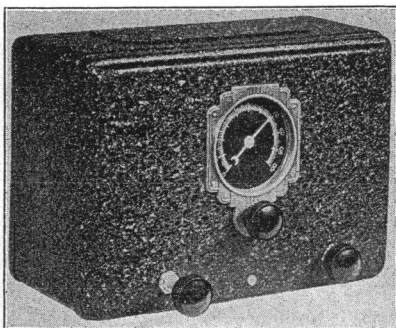

The Pre-Selector is mounted in one of the new Crowe Metal Cabinets, with illuminated airplane dial.

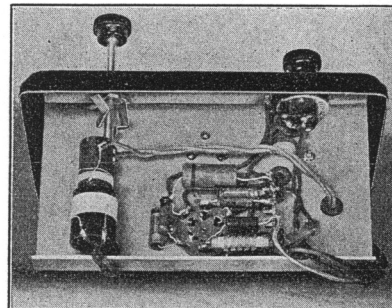

Under the chassis. All wiring is plainly visible. A twisted-pair of flexible leads is attached to the movable coupling coil, as shown.



extremely well. Reduction of capacitive coupling to the antenna, if the latter uses a two-wire feeder, means less pick-up from the down lead and consequently a great reduction in automobile ignition interference. The latter is usually bad on 20 meters and occasionally even on 40 meters.

The smaller antenna coil is fastened to a piece of 1/4-in. diameter brass rod, 3 3/4-in. long, by means of two 6/32 machine screws through the brass rod and bakelite tubing. This rod slides through an ordinary telephone jack of the short type and the plunger action of this coil is controlled by means of a knob on the front panel which pulls in and out. The jack acts as a bearing and the jack spring presses against the rod and holds it in place at whatever point is necessary. This is a very simple mechanical device which has proven very satisfactory for adjustment of antenna coupling.

The tuning condenser can be any of the midget types having good insulation and a maximum capacity of about 100 mmfd. A small aluminum bracket holds the condenser at the proper level for the airplane type dial

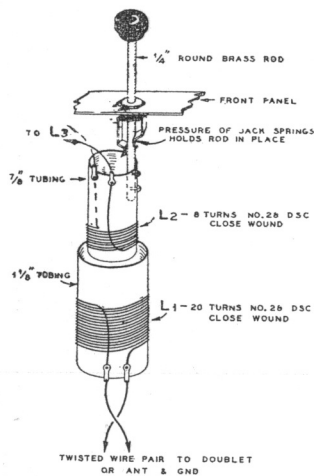

Showing how to build the Variable Antenna Coupler. A 7/8 inch tube slides into a 1 1/8 inch tube. Coupling is varied by means of a brass rod slider, which is supported by an ordinary headphone jack. The round brass rod can be filed so that it will have two flat sides; the jack contacts will then grip the rod in such a manner that the movable coil will not "wobble" when the coupling is varied. The number of turns on L1 and L2 is the same, no matter what frequency range is to be covered by the Pre-Selector.

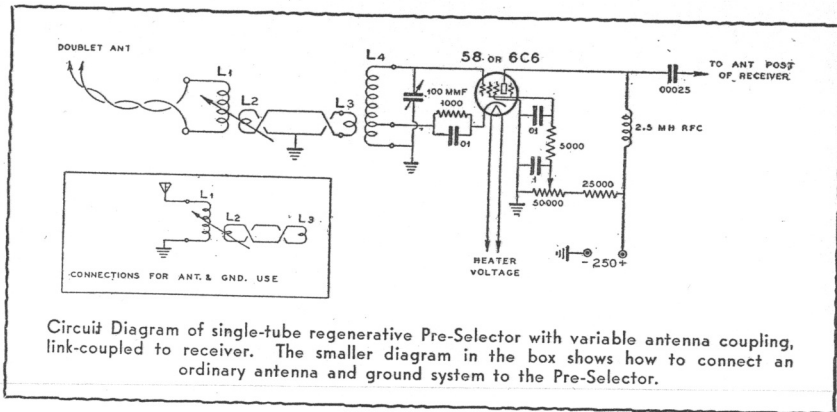

Circuit Diagram of single-tube regenerative Pre-Selector with variable antenna coupling, link-coupled to receiver. The smaller diagram in the box shows how to connect an ordinary antenna and ground system to the Pre-Selector.

- LEGEND FOR PRE-SELECTOR**
- L1—Same for all bands. 20 turns, No. 28 DSC, close wound on 1 1/8-in. dia. tubing.
  - L2—Same for all bands. 8 turns, No. 28 DSC, close wound on 7/8-in. dia. tubing. Coupling between L1 and L2 variable. L2 slides into, and out of L1.
  - RF COIL FOR 160 METERS
  - L3—10 turns, No. 22 DSC, close wound on 1 1/2-in. dia. low-loss coil form.
  - L4—60 turns, No. 22 DSC, close wound, and tapped 1 1/4 turns up from ground end. L4 is wound on same coil form as L3, and is spaced 1/4-in. from L3.
  - RF COIL FOR 80 METERS
  - L3—7 turns, No. 22 DSC, close wound, on 1 1/2-in. dia. form.
  - L4—35 turns, No. 22 DSC, close wound, and tapped 1/2 turn up from ground end. Spacing between L3 and L4 to be 3/8-in.

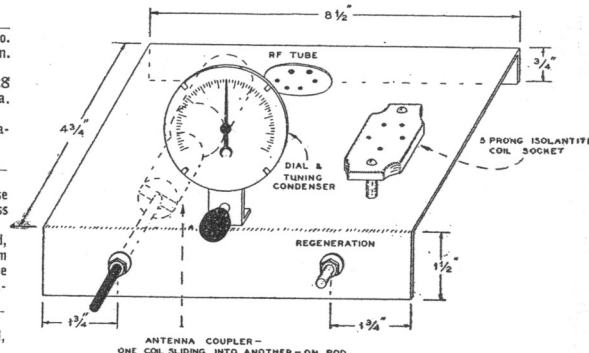

Good results can be expected only when the parts are properly placed and spaced. The illustration shows the correct chassis layout.

- RF COIL FOR 40 AND 20 METERS
  - L3—5 turns, No. 22 DSC, close wound, on 1 1/2-in. dia. form.
  - L4—12 turns, No. 18 DSC, space-wound over a winding space of 1 1/4-in., and tapped 3/4 turn from ground end.
- NOTE**—The ground end of the L4 is the bottom of the coil. The top end of L4 connects to the grid of the 58 or 6C6 tube in the Pre-Selector.

used on this set. The parts are mounted on a piece of 12-gauge aluminum bent in the shape of an inverted U. The original piece should be 8 1/2-in. long and 7-in. wide. 1 1/2-in. on the front edge and 3/4-in. on the rear edge are bent down, so the top of the chassis is 8 1/2-in. by 4 3/4-in. The antenna coupler mounts underneath on one side, and the regeneration control on the other; the entire unit mounts in a can which comes equipped with dial. The approximate dimensions of this can are 9 1/2-in. long, 5-in. deep and 6-in. high. The front and back are removable so

the coil can be changed by snapping off the rear cover or by means of an opening in the rear. The dial is fastened to the chassis by means of a right-angle bend in the dial mounting strap and fastening the latter down with a machine screw. The chassis is fastened to the front cover or panel.

It is desirable to twist the antenna leads together for the two leads into the pre-selector. The plate coupling lead should come out at the other side of the rear cover and be as short as possible in its connection to the radio receiver. Coupling between this plate lead and the antenna would cause undesirable effects. Power for the tube can usually be obtained from the receiver because it only needs heater current and a high voltage tap of from 180 to 250 volts. If a doublet antenna is not used, one of the antenna leads should be grounded.

## Problems Encountered When Changing From C. W. to Phone

### By LINEAR

● CW telegraph operation is subject to considerably more leeway in design, construction and adjustment of the transmitter than is allowable for phone operation.

In CW the signal is composed of merely a mark or a space. In other words, the variation from carrier to no carrier condition is the means of transferring the transmitted intelligence from one point to another. The character and quality of the transmitted signal is relatively unimportant just so long as there is a definite and readable difference between the carrier on and off conditions in the output of the distant receiver.

In the phone transmitter the carrier is on all of the time and the transmitted intelligence is observed by the receiving operator as a variation in the amplitude or intensity of the received carrier. In order for the carrier variations to be as readable as possible, it is essential that all extraneous carrier noise

and hum be eliminated so that the contrast between the voice "off" and the voice "on" conditions will be as great as possible.

This reduction in carrier noise requires the use of more extensive hum filtering in the power supplies that feed plate power to the various stages of the phone transmitter than is required in a CW transmitter. It also necessitates the use of a speech amplifier at the transmitter, adjusted and shielded so that all hum and feedback whistles are kept to the absolute minimum.

There are other requirements for satisfactory phone operation which must be observed.

(1) The equipment must be maintained in proper adjustment so that the radiated signal will be a perfectly modulated equivalent of the speech sounds originally impressed on

the microphone so that the received signal will be of the highest fidelity, and thus will be highly intelligible. This requires that the modulation be linear and that the frequency distortion be held to a minimum.

(2) The equipment must be designed and adjusted so that the transmissions cause the absolute minimum of unnecessary interference to other services. This requires keeping carrier shift (non-symmetrical modulation) and overmodulation to a minimum. It also necessitates the use of enough buffer stages and oscillator isolation so that the radiated signal is free from frequency modulation. All parasitic oscillations must be eliminated so that the radiated carrier is all on one frequency.

The first step for the CW man who is changing over to phone operation, is to make his CW transmitter 100 per cent per-

(Continued on page 33)

# Addressed to Members of Congress

By COL. CLAIR FOSTER, W6HM

THE air is the people's domain. It belongs to all of the people, just as did the public lands and all natural resources of the country before the robber barons of the last century, with the aid of men they controlled in Washington, sequestered to themselves billions of dollars worth of these lands and other natural resources. The robber barons of the present century have grabbed great areas of the people's air for their own private use and profit. Let the people who own the air try now to secure a broadcast channel for their own purposes; they may do so only if they have the money to buy one from a private corporation that obtained it for no price at all. They may buy one from an interest that obtained it, just as they may buy at a big price farm lands, mineral lands, timber or water-power sites from men who took them for nothing from their legal owners. Let the Government itself try now to take back one of these gift channels for its own use, and immediately would go up the cry that short-wave channels are now worth a million dollars apiece and that the peoples' taking back one of their own airplanes would be "confiscation of private property."

A large part of the short-wave area is controlled by private corporations which were favored with extreme lavishness in the matter of channel assignments and which now have practical use for only a fraction of them. It goes without saying that the corporation and government employees who assigned the channels will deny this but radio men as a class know that it is true.

And while these channels lie useless to the people who control them and to the people who own them, some 46,000 citizens of the United States who have great use for them have been prevented by force from using any part of them. These citizens are the non-commercial users of the air commonly known as "amateurs", who own and operate transmitting stations.

The discoverers of the science of radio were amateurs—men who experimented without thought of money reward. The first developers of radio as a useful art were amateurs—men who worked without the expectation of pecuniary return. Marconi is now commonly acclaimed as the father of radio. When he came upon the scene such a title would have been greeted with sardonic smiles. Marconi was not the scientist, he was the promotor type that appears in every new activity that gives the hope of securing money backing from the public. The question of safety of life at sea was the popular appeal used for securing money to make a money-making art out of the science of radio. Virtually all of the men whose discoveries advanced the art of radio have been amateurs. After the money-making possibilities of radio became apparent, commercial organizations grub-staked amateurs—paid them a living wage for experimenting in the names of the corporations.

In the early days of radio it was the universal belief that long-distance communication could be had only by the use of long waves and high power. It was found that for short distances—such as from ship to ship and ship to shore—the then "short wave" of 600 meters was suitable, and that wave became established as the one on which ships would transmit and listen. At that time the sole visualization of radio as a practical art was its use to provide safety of life at sea to fill the needs of sea-going people where no

wire communication was possible. There was no thought of using "wireless" on land; there was no need of it over land in those days. For that matter, there is still slight call for it over land areas. Wire communication has spread as fast as our country's needs. Wire communication has always been—and always will be—more dependable. Even the trans-Atlantic message traffic is carried chiefly by the wire cables. For all the high development of the commercial radio systems they transmit only a small percentage of the daily trans-Atlantic business—I believe less than 15 per cent—simply because the cable service is more satisfactory to the public. Other uses for radio had not been conceived. Nobody dreamed of broadcasting music or the human voice. In fact it was not until years later when an amateur who was a student at Columbia University discovered the "feedback" principle that this became possible. If it had not been for the work of this amateur there would be no such thing as broadcasting as we know it today.

Since safety of life at sea was the prime objective, and such ships as were equipped with apparatus were using the 600 meter channels, it became necessary that amateurs avoid interference with this vital function of radio. The men who by this time had sensed the money-making possibilities of radio wanted no amateurs in the field at all. They contrived to have our Government representatives relegate the amateurs to 200 meters where they might still conduct experiments but could do no communicating over the air. At that time every radio man in the world was convinced that waves as short as 200 meters were useless for communications; so the amateurs were given all of the waves from 200 meters downward!

These indefatigable experimenters then went to work to do what they could with 200 meters. The then means of creating radio impulses could not be made to function reliably so low as that, but by the use of vacuum tubes and the feedback principle the amateurs soon discovered means for generating them. They discovered, moreover, that with their newly developed apparatus they could cover far greater distances than with 600 meters, and with the use of far less power. The word was passed around and the amateurs bent their efforts to conquering the still lower waves. And as they developed apparatus that would function at shorter waves they discovered that the lower they went, the greater distances their signals could be heard. With this principle experimentally established, they gradually devised transmitters and receivers that would work at lower and still lower waves. By 1923 they were communicating successfully across the Atlantic ocean on 100 meters and with very low power. In 1924 quite a number of amateurs were working with success on 40 meters. During the winter of 1924-25 a few had succeeded in making apparatus that would operate at the tremendously high frequency of 15 million vibrations a second that corresponds with the wavelength of 20 meters. On this wave they were conducting communications clear across the continent at mid-day, a previously unknown feat on any wave with any power.

Of course the commercial radio interests were aware of these developments but so sure were they of the uselessness of these short waves for their purposes that they held to their original theory—long waves and high power for long distances. But a few men of the Naval Bureau of Research, (in charge of

a gifted amateur, by the way), had agreed with the amateurs. They sought the aid of the amateur stations in making practical tests under working conditions. By the middle of 1925 the amateurs were covering unbelievable distances with 40 and 20 meters and exceedingly low power. By "low power" is meant from 10 to 50 watts, as compared with the commercials' 10 to 50 thousand watts used on their long waves.

And still the commercial people poo-pooed these short-wave achievements. They declared in so many words, "Oh, yes, these amateurs pull a few stunts now and then under extraordinarily favorable conditions but they cannot repeat them day after day." Even the Navy was not convinced until after the cruise of the fleet to Australia in the summer of 1925. When the cruise was projected the higher officers of the Navy were lukewarm on the subject of trying anything so radical as the new "amateur" waves. The amateurs had to beg the Navy to equip some of the ships of the fleet with 40 and 20 meter apparatus in addition to the regular sets operating on the ship waves. The Navy finally acquiesced. A few amateurs were inducted temporarily into the service to design and build the short-wave apparatus, install it and operate it on the cruise. In some cases these amateurs even supplied for the short-wave sets equipment bought out of their own pockets. The practical result was that after the fleet left Honolulu and the regular ships' apparatus could no longer communicate reliably with the mainland, the amateur apparatus on the flagship "Seattle", conducted virtually all of the mainland traffic all of the way to Australia and back—even to communicating regularly direct with Washington, D. C., by way of the short-wave station at the Naval Bureau of Radio Research, aforementioned. Just here it may be of interest that while the fleet was at Honolulu an amateur in Johannesburg, South Africa, was copying the "Seattle's" short-wave messages—just half way around the world!

This demonstration during the cruise of 1925 caused the commercial people to change their minds about the value of the short waves. They hired many amateurs and put them to work developing short-wave apparatus for commercial use. By 1927 the commercials were rather well equipped. The General Electric Company, the dominant interest in the Radio Corporation of America, hired dozens of amateurs. Among others they employed Billy Jackson, a boy just out of college, and owner of the famous amateur station 1CMP. In the Schenectady shops of the General Electric, Bill designed and built a short-wave station for the RCA. He himself went to the RCA's big trans-Atlantic station at Rocky Point, Long Island, erected it, got it into operation and drilled the commercial operators in its use and care. Signing the call, WLL, it immediately went into operation—in a little galvanized iron shack costing perhaps \$100—working Argentina regularly on about 15 meters. Another set like it was built for working across the Atlantic. And then and there all of the millions of dollars worth of long-wave apparatus of the Rocky Point establishment, (including the famous Alexander alternators which had been expected to give General Electric complete command of the long-distance communications of the world), became just so much junk. And Bill was drawing the huge stipend of \$40 a week! Much was printed about the General

(Continued on page 26)

# Limitations of Plate Supply Transformers

By I. A. MITCHELL\*

• When a commercial organization purchases transmitter components or equipment, the first factor which must be considered is the dependability of the apparatus. A two-hour shutdown on a broadcast schedule may be worth many times the cost of a tube or some other component. However, the amateur is more interested in getting the maximum possible output from his equipment, and consequently is not at all conservative in living up to manufacturers' maximum ratings. The most frequent example of this is in the operation of vacuum tubes above manufacturers' ratings. This is often a sound economical practice. For example, a pair of 59 tubes when operated at 30 per cent above rated voltage will generally deliver approximately 50 per cent greater power output. However, the tube life is shortened; let us say 50 per cent. Since the replacement cost of the 59 tube is extremely low, there will still be an appreciable overall economy as compared to the initial and operating cost of a larger amplifier system equivalent to the 59 amplifier operated above normal rating. Sometimes the amateur stretches this reasoning a little too far. Let us illustrate this with a hypothetical chapter in the life of a hypothetical individual by the name of Joe Ham, call letters W5HAM.

Sometime ago Joe decided that he wanted to change his 171A transmitter to a high power unit using 59's in class B. A thorough search in the junk box showed that most of the material necessary was available except for the plate transformer. Joe had to wait four days until pay day, but he finally got down to his jobber and got the latest Umpty-Umph plate transformer for 59's; rated at 550 volts each side, 200 mills DC. That night the midnight oil burned heavily and at about 2 a.m. the modulator was finally completed. A standard circuit had been followed and a plate current meter provided in the 59 circuit to operate as a power indicator. With an admiring audience surrounding him, Joe connected up his mike and started talking. Suddenly, he discovered that the plate current output meter was barely wiggling. It took two hours work to finally pin the difficulty down. Joe discovered that while 470 volts DC was measured after the rectifier tube, only 240 volts appeared at the 59 plates with maximum signal. Another half hour's work placed the difficulty in the two filter chokes taken from the junk box which turned out to have DC resistances running into four figures. Realizing that he would require more voltage to really get any power from his tubes, Joe changed his filter circuit to condenser input. This brought his voltage up to 300 volts, but here again he could only get about 5 watts audio output. The plate voltage on the 59's varied from 550 to 300 volts for different signal levels due to poor power supply regulation. Suddenly Joe discovered that it was 5 a.m. and went to bed to dream about chokes and plate current meters.

By the following night Joe decided that 59 tubes were no good anyhow and class B was certainly terrible and so he looked over his tube rack to see what other power tubes he might have available. A pair of 845's were discovered that had come out of the audio amplifier in his local movie theatre. However, here the question of power supply became a difficult one. 1000 volts on the plate at 150 mills was required. Joe decided to get authoritative information on power supplies, so he looked up his June 1934 issue of "RADIO" and discovered that using a bridge

rectifier with the 1100 volts power transformer recently purchased, he would be able to get approximately the 1000 volts desired. Joe finally managed to exchange his high resistance chokes and his 59 tubes for a pair of decent resistance filter chokes that somebody else wanted to get rid of. The circuit was set up and the power supply plugged in. Suddenly there was a hissing, arcing sound and after a little reconnoitering, Joe discovered that electrolytic condensers while fine for low voltage power supply would not work on 1000 volts DC. The blown condensers were replaced with paper ones and the power supply finally worked. However, Joe had not considered the bias required by the 845's. For 1000 volts on the plate, 150 volts bias was required which meant that a total of 1150 volts DC was necessary from the plate supply. This was finally obtained by using condenser input. At about 1 a.m. the rig was finally working in excellent shape. Joe started "seek-youing" and by 2 a.m. had succeeded in contacting someone 1000 miles away. Over and above the excitement of

During lunch of the following day Joe returned his plate transformer to the jobber with vicious remarks about poor transformers "that break down after only two hours of service at 150 mills."

Joe, however, was one of these boys who really was interested in knowing how the wheels go around. He began to figure out that after all while it was true that only 150 mills DC had been obtained, there must be some difference in the transformer operation in full wave or bridge rectification. He finally decided to get some meters together and actually find out what conditions occurred in transformers operated as he had operated them. He used a 100 mill DC load for all measurements and 8 mfd. condensers.

Fig. 1 illustrates the result of his work. He discovered that when he changed from choke input full wave rectification (A) to condenser input (B), the AC current in his transformer secondary had changed from 71 mills to 103 mills. Also, simultaneously, the primary current of the transformer had gone up from .6 amp. to .9 amp. When he went to the bridge rectifier, (C), he found the secondary current again about 100 mills, but the primary current had risen still higher, to 1.1 amps. Finally, in the last method he had originally used for his transmitter, that is, condenser input (D), the AC current in the transformer secondary was 148 mills and the primary current 1.65 amps. Naturally, it was apparent to Joe that the transformer had burned out due to abuse rather than poor workmanship.

It is interesting to analyze the results shown in Fig. 1. These results can be applied to any standard rectifier. The ratio of AC to DC current, etc., can be definitely taken from this data. Where condenser input is used, the AC current will depend considerably on the value of the condenser and the value of DC load. The critical factor in the output available from a power transformer is the transformer's temperature rise. Insulation as normally used in the winding of power transformers will not stand up above certain limiting temperatures. The temperature rise in a transformer is almost directly proportionate to the ratio of the total wattage loss in the transformer as compared to the heat dissipating surface of the transformer. In the normal design of a transformer, this wattage is approximately equally divided between iron losses and copper losses. The iron losses are not affected very greatly by load but the copper loss is. Following the law of our old friend Ohm, we find that wattage losses in the windings of a transformer are equal to  $I_{ac}^2 \times R$ , where  $I_{ac}$  is the effective AC current in the winding and the R the resistance of the winding. The value of  $I_{ac}$  in the secondary, while directly proportionate to the DC current, is not equal to the DC current. This is apparent from Fig. 1.

Again referring to Fig. 1 and using the  $I^2R$  principle, we find that if we take the wattage loss in (A) as normal for the transformer windings, the wattage loss in (B) is approximately double in both primary and secondary; that is, the AC current has increased to 1.4 times its original value and squaring this, we get 2.

In the bridge rectifier, while the loss in the secondary winding is double, the loss in the primary winding is more than tripled. Going still further to the condenser input bridge rectifier (D), we find that the secondary winding loss is  $4\frac{1}{2}$  times that in A and the primary loss is  $7\frac{1}{2}$  times that in (A). If we refer to the previous statement

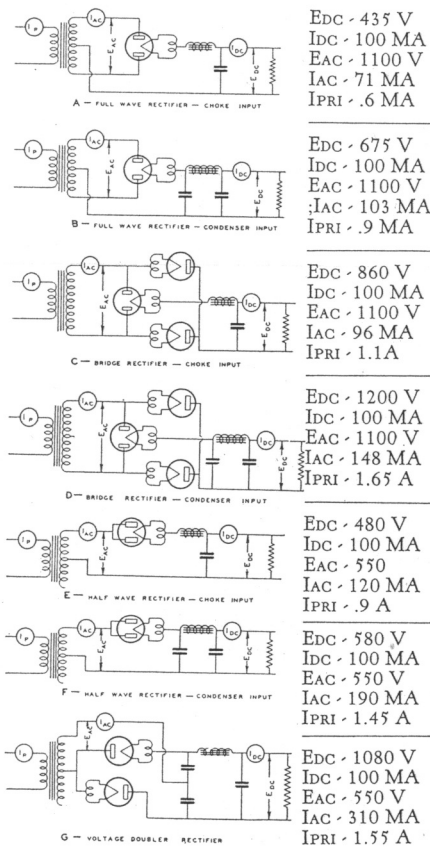

FIG. 1

operating his new transmitter, Joe began to smell a peculiar odor permeating the atmosphere. Suddenly everything went black. Something had gone wrong with the power supply and as it had not been fused, the main fuse in the basement had blown. A candle was finally located and Joe went down to the basement to replace the fuse with a piece of solder, and came back to see what was wrong. It did not take long to ascertain that the plate supply transformer had failed.

\* Chief Engineer, United Transformer Corp.

# The Browning "35" With Tobe Tuner

By GLENN H. BROWNING

FOR the last year the writer has felt that there was a distinct demand for a coil and tuning condenser assembly which would cover efficiently a frequency range from about 20 megacycles to 550 KC. Such a device should of course be as compact as reasonably possible, and be electrically and mechanically designed so that it could be used as the heart of an all-wave or short

much be made for shorting out all coils in the catacomb which are not in the circuit being employed. These specifications are rather rigid but switch manufacturers have attacked the problem and have finally

The switch used has silver contacts, extremely low losses and capacitances, and shorts out all coils not actually in use. The short wave coils are space wound with silver plated wire which has about 5 per cent less resistance than copper. The coils covering the broadcast band are bank wound with Litz wire. The inductances used in antenna circuits are all mounted in one shielded



● Messrs. Browning, Tobe Deutschmann and Dorf put the new receiver through a series of all-night tests at the "Radio News" Westchester Listening Post. Glenn H. Browning (in foreground) is remembered by many an old-timer as the originator of the Browning-Drake Receiver which made history in the pioneer days of radio.

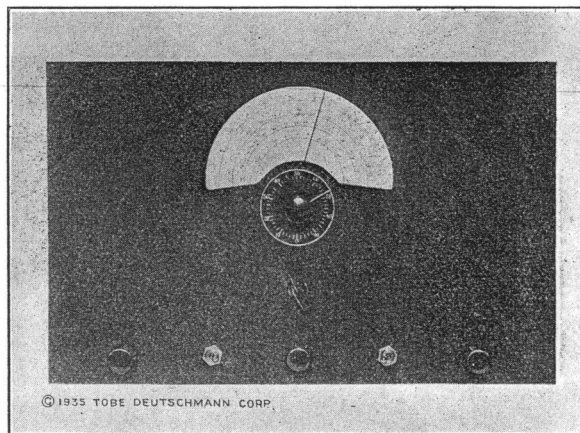

● This view of the new BROWNING 35 with TOBE TUNER shows the neat layout of the front panel. A laboratory dial of large size is used. It makes for easy logging of stations. Glenn H. Browning has contributed a number of practical features to this new receiver which should appeal to amateurs and short-wave fans alike.

wave receiver according to the desire of the experimenter or amateur.

A study of the problem of "plug-in" coils vs. a coil switching arrangement brought out the fact that better efficiency could, by careful design, be obtained with the latter system.

In the first place "plug-in" coils must have two wiping contacts per coil while in coil switching only one contact need be changed. True, the switch used must make good electrical contact, as well as having low capacitances and low losses between its parts and at the same time provision

brought out a product which, in the writer's opinion, sounds the death knell of "plug-in" coils.

The Tobe 35 Tuner is the result of months of work on an all-wave tuning catacomb. The mechanical as well as the electrical details have been carefully worked out for obtaining maximum gain and selectivity. As will be noted from the wiring diagram, the TUNER incorporates the switching arrangement as well as the coils, trimming, and the tuning condensers for a tuned antenna circuit, a tuned stage of RF amplification on all frequencies, and an oscillator circuit.

compartment, the inductances for the tuned RF stage are located in the second shielded compartment, while the oscillator inductances are in the third compartment. This eliminates any interaction between circuits which would cause a "locking-in" effect. The trimmer condensers for each coil in each circuit are mounted in the respective compartment. One single three gang tuning condenser is located on top of the coil catacomb. Thus the unit is absolutely single control. The whole TOBE 35 TUNER is wired (bare wire is used to reduce losses\*), lined up and tracked at the factory so that the experimenter will obtain good results without realignment. However, as tubes vary, some slight adjustments are necessary for maximum gain. It is only necessary to make seven connections to the TUNER, in constructing a complete receiver.

The TUNER catacomb is mounted in the main chassis by means of gum rubber cushion insulators. This entirely eliminates the pick-up of ground currents from the main chassis and at the same time minimizes acoustical mechanical vibrations of the tuning condenser plates which contribute materially to microphonics.

The TUNER is grounded to the main chassis in one point only. This grounding connection should be made by means of a flexible copper braid of low resistance. Care should be taken that the front panel does not make electrical connection to the TUNER.

The frequency spectrum covered by TOBE 35 TUNER is from 23 to .55 megacycles. As

\* Most insulation on wire is hygroscopic and picks up moisture from the air with the result that its power-factor is high. Also the dielectric constant of the insulation is greater than air, and tends to increase slightly the capacitance between wires. These effects are not negligible at the higher frequencies.

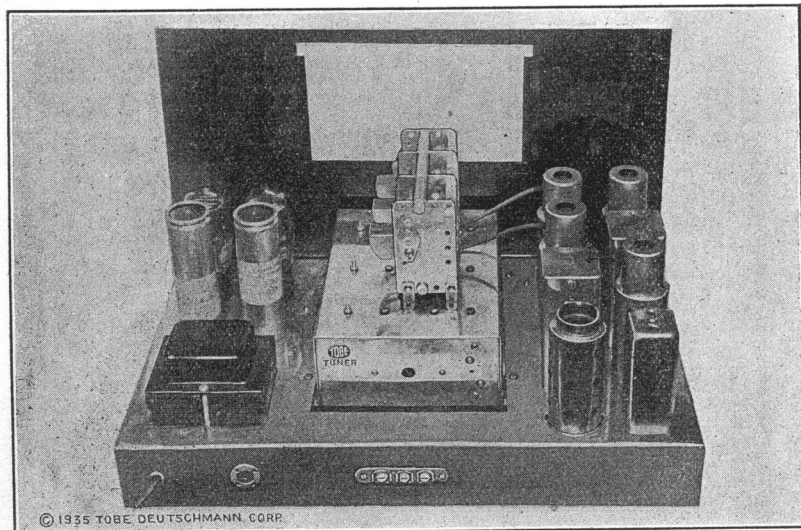

●Rear view of the laboratory model of the Browning 35 with Tobe Tuner

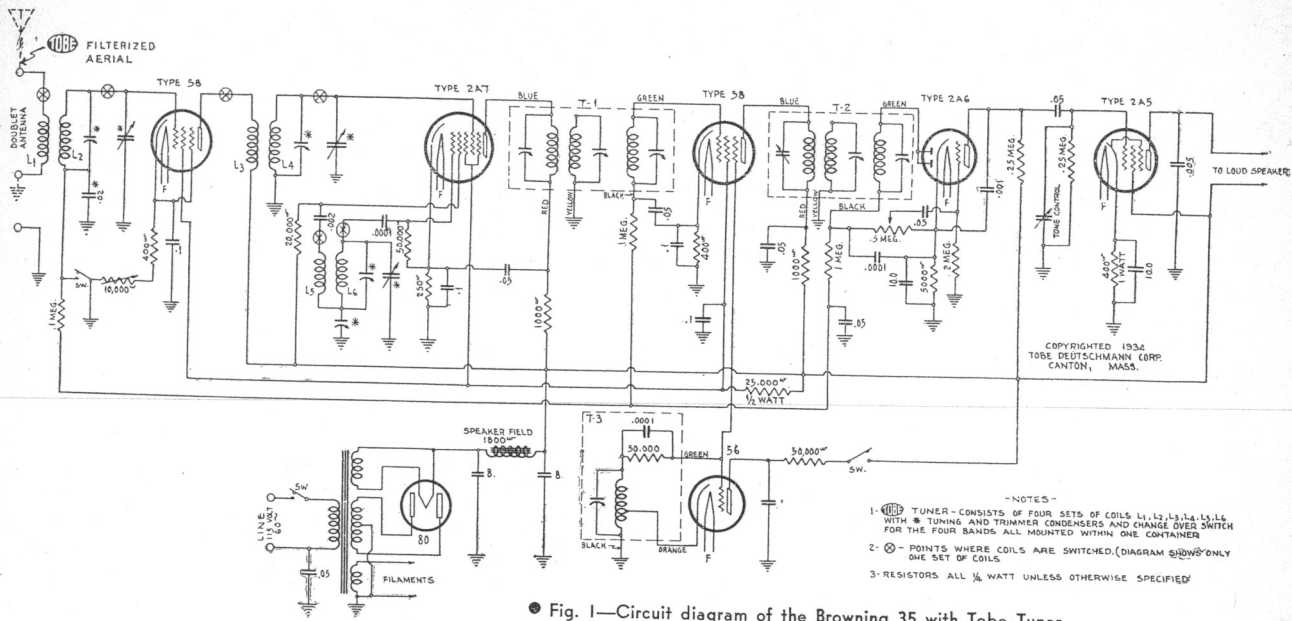

• Fig. 1—Circuit diagram of the Browning 35 with Tobe Tuner.

before indicated four sets of coils are used. The first set goes from 23 to 8.5 MC, the second from 9.2 to 3.4 MC, the third from 3.75 to 1.4 MC, and the fourth from 1.6 to .55 MC.

The three gang tuning condenser is equipped with a micro-vernier arrangement so that band spreading is accomplished mechanically. A pointer is attached to the main shaft of the condenser, and moves over a dial calibrated in megacycles. A second pointer is attached to a micro vernier tuning knob and rotates 360 degrees over a scale divided into 100 divisions. The band spread given on the first band (highest frequency) is 10 KC per division, on the second band is 5 KC per division, and on the third band is 2.5 KC per division.

This system has an advantage in as much as the receiver is absolute single control, and the use of a single gang of tuning condensers allows the minimum capacity across the tuning coils to be low, thus larger inductances may be employed and greater sensitivity obtained.

Fig. 1 shows the TUNER used as the heart of a superheterodyne receiver which in itself has several features. The most outstanding feature is the intermediate frequency amplifier, which is in reality a band pass filter made up of three tuned circuits so coupled together that a fiat "nosed" response curve results. The band passed by the intermediate is about 5 KC wide and consequently there is little attenuation of the higher modulating audio frequencies, which results in improving the quality of the receiver to a noticeable degree.

The coupling from the 58 intermediate amplifier tube to the 2A6 diode detector and amplifier is made through a specially designed band pass filter, which differs materially from the former band pass filter. The response curve obtained in the intermediate amplifier as a whole is shown in Fig. 2 curve A where voltage ratio is plotted against KC off resonance. For comparison purpose an ordinary high Q tuned intermediate transformer and coupling stage are shown by curve B. It will be noted that the usual intermediate tuned circuits are sharper at the "nose" of the curve, resulting in poorer quality, but at a voltage ratio of 100 times or 40 db that the selectivity is much worse

than the band pass circuit. Thus the intermediate amplifier gives rise to a very high quality receiver.

After considerable experimenting 465 KC was decided upon as the best intermediate frequency for such a band pass filter; going much higher resulted in losing selectivity, while decreasing the frequency resulted in coils which were larger than it seemed feasible to employ.

As has been previously stated the receiver has a stage of RF amplification before the

coil is tuned at 1000 cycles higher than the intermediate frequency. However, the condenser which tunes the circuit is adjustable so that the experimenter or amateur may change the beat note at will. The oscillator should not be tuned to the same frequency as the intermediate, for in that case if the incoming signal was exactly tuned in, no beat note would be heard and it would be necessary to detune the signal slightly in order to obtain the beat note. Frequently interfering code stations may be received by adjustments of the beat oscillator which will result in readable signals from either or both.

Automatic volume control has been incorporated. The voltage for this control is obtained from the 2A6 diode circuit. A short circuiting switch is included so that AVC may be used at will.

Two volume controls are used. The 10,000-ohm control on the RF 58 tube is an auxiliary to preclude any possibility of overload and at the same time is an added precaution against any possibility of "cross talk" or "cross modulation." This control should be retarded especially on broadcast. The main volume control is connected in the diode circuit of the 2A6 tube, and consists of a .5 megohm potentiometer.

The overall sensitivity of the complete receiver is less than a microvolt on all bands.

The next article will give complete constructional data as well as performance curves on the new receiver.

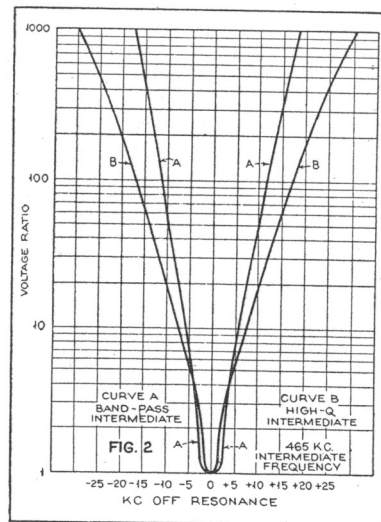

• Fig. 2—The advantages of double-band-pass are clearly shown in the curve, above.

2A7 mixer tube on all bands. This is extremely essential for not only does it eliminate "image" and "pseudo image" frequencies but it also adds materially to the sensitivity and selectivity of the receiver.†

A beat frequency oscillator is incorporated as an integral part of the receiver so that CW signals can be received. A switch in the plate circuit of the 56 oscillator tube turns off this oscillator at will. The beat frequency

† "Image frequency may be explained as follows: If the intermediate frequency of a superheterodyne is say 400 KC and it is desired to tune in a signal of 1000 KC the local oscillator in the receiver may be tuned to either 1400 KC which is the usual practice or to 600 KC. In either case the difference between the local oscillator and the signal will be 400 KC or the intermediate frequency. Suppose the oscillator to be tuned 1400 KC and 1000 KC signal is being received. A station transmitting on 1800 KC will also be received if the signal gets to the grid circuit of the mixer tube, for it also produces the intermediate frequency of 400 KC. The result of the "image frequency" of 1800 KC is interference.

If two transmitting stations are separated by the intermediate frequency and their signals are allowed to get on the grid of the mixer tube they will also produce the intermediate frequency and be amplified whether the local oscillator is functioning or not. This is known as a "pseudo image."

# The Lafayette P-46 Thirty-Watt Transmitter

By FRANK LESTER, W2AMJ\*

THE "Les-Tet" exciter using the 2B6 tube is rapidly gaining favor with amateurs as a simplified, convenient and easily adjusted transmitting unit. It can be used by itself to form a low-powered rig with an output of about 5 to 7 watts, or it can be used as a driver for power stages using much larger tubes. In the Lafayette 100-watt transmitter, for instance, the 2B6 excites two RK-20s in push-pull, with an output of 100 watts on CW.

Many amateurs who cannot afford this large outfit, but who want more "pep" than afforded by the 2B6 alone, have requested data on a medium powered transmitter using inexpensive tubes. The 46s seem to be the favorites, probably for the reason that they cost only about 65 cents each retail, and replacements can be made without straining the family bankroll.

Two 46s connected in parallel as a Class C final amplifier were found to afford a very conservative output of about 30 watts, 600 volts being applied to the plates. The final circuit that was selected for a complete, self-contained transmitter now being marketed under the Lafayette name is shown in Fig. 1. Tube V1 is the 2B6, which consists of one very small triode and one large triode in one envelope, with the cathode of the former connected inside the tube to the control grid of the latter. The crystal is connected across the grid-cathode section of the small triode, with the cathode-plate tank, consisting of L1 and C1, between the cathode and ground. The large triode acts as a direct coupled amplifier, its plate circuit containing the tank L2-C2. Neutralizing voltage to overcome feedback effects through the grid-plate capacity of the amplifier triode is supplied by the bottom section of L1, through the small neutralizing condenser C4.

The 46s are operated together as a straightforward, neutralized Class C stage, with the plate tank coil L3 tapped for neutralizing e.m.f.; C5 is the neutralizing condenser.

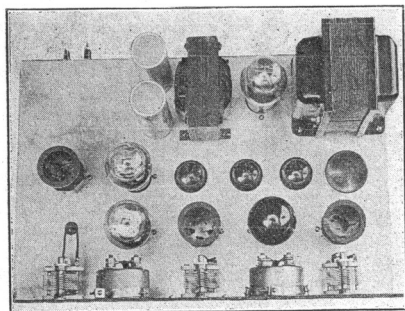

Chassis view of the Lafayette 30-watt transmitter.

The variable bias resistor R1, in the cathode of the large triode section of the 2B6, acts as a very simple and effective excitation control for the 46s. A fixed resistor of 1000 ohms (R2) is provided so that there is always some bias on the 2B6 even with R1 turned down to zero.

For power supply, an 83 is used in a fool-proof, standard hook-up, as shown. The bleeder resistor R5 has one tap, for the plate of the oscillator. The filter condensers are 1000-volt electrolytics.

\*Engineer, Wholesale Radio Service Co., Inc.

Three separate single-pole snap switches, SW1, SW2 and SW3, are included in the circuit. The idea is to close SW1 first, giving all tube heaters a chance to warm up. SW3 is then snapped, closing the B return circuits to all tubes. During reception pe-



The assembled Lafayette 30-watt transmitter using the 2B6 and 46 tubes.

riods, SW3 is left open so that the 2B6 is inactive and does not swamp the receiver when the latter is tuned near the operating frequency.

The other switch, SW2, is a convenience in neutralizing the 2B6. Since plate voltage must be supplied to the oscillator section but not to the larger triode during this operation, it is not feasible to open the common B-minus return. SW2, however, opens the amplifier (or rather buffer, in this case) plate circuit by ungrounding the cathode, and neutralizing can then be easily done.

Neutralizing the parallel 46s, V2 and V3, is easy enough; simply leave the key up.

The proper procedure is as follows: Put all tubes in their sockets. Close SW1, then SW3, with SW2 open. Let us assume the

outfit is to work straight through on the crystal frequency. Plug a 0-25 ma. milliammeter into J1 and tune C1 for minimum plate current with C4 and C2 set at zero. The oscillator will be more stable with C1 set a little lower (in capacity) than exact resonance. The receiver must be kept going, with the antenna disconnected, so that the output can be heard and checked at all times.

With SW2 still open, rotate the buffer condenser C2 over its entire range and closely watch the plate current reading of the oscillator section of the 2B6. As the L2-C2 circuit approaches resonance with the crystal frequency, the plate current as measured at J1 will increase, and in some cases the crystal stage will stop oscillating altogether. Now simply adjust the neutralizing condenser C4 gradually until the oscillator plate current remains steady no matter where C2 is adjusted. The buffer stage is now neutralized.

Close SW2, plug a 0-200 ma. meter into J2 and tune C2 for minimum plate current. The steady signal in the receiver should take a big jump in strength. You can see if the

(Continued on page 28)

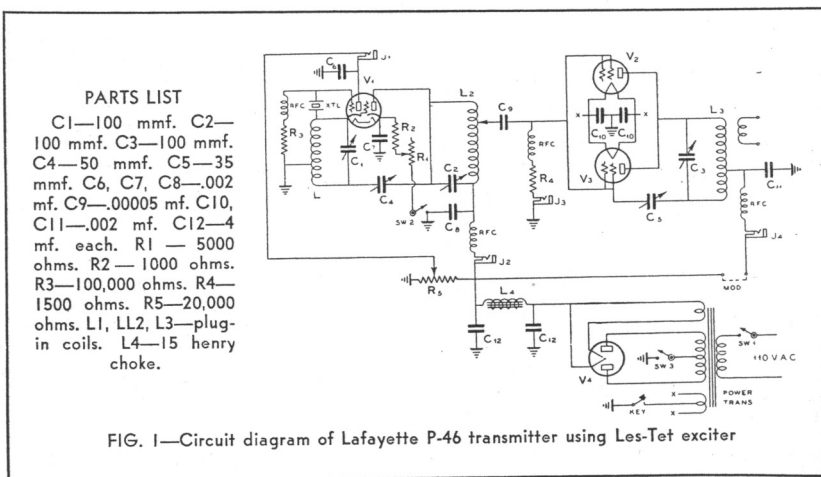

# Ham Shacks

By C. C. ANDERSON, W6FFP

THE mention of shacks to the average W ham brings to mind an enclosure of some walls, a window shut full of holes, and a door that will not open without first clearing away the pile of junk in back of it. To walk into this shack requires high steps, with an occasional reaching down and untangling feet from strewn wire. Then the vision of the "rig" appears, yet there is difficulty in finding the distinction with the junk on the floor and this "rig" that is supposed to put out an RST 599X signal. The throwing of a switch will light some tubes in the region of the transmitter (if no fuses blow), forming this distinguishing line between the junk on the floor and the transmitter. The operator then dives into another mess on a table, and with sweeping strokes clears away a spot and calls it "the operating position". However, to turn off the rig, he has to stumble across the room to find the switch again. Then, to take a photo of this heap, for a few minutes all the spare junk is piled back of the camera, with the resulting photo giving appearances of a neat contrivance called a transmitter and receiver. Before clicking the camera, something seems to be missing from the picture and a tin can with a dial and calibration chart is placed next to the receiver and labeled "calibrated frequency meter and monitor". Is not that picture familiar? Our shack is a den of torture, not a place for relaxation and fun. We make work out of every QSO, with the result—we begin to hate the sight of the old heap, and start building a new one, and in two weeks the result is the same—parts strewn all over and the shack is just one more big junk pile. With that common vision of a W ham shack in mind, let us see how our foreign friends manage to keep from losing their nerve and mind when they chew the fat with us.

A good example of a foreign shack comes to mind when we look over our foreign correspondence and fotos. But even though we smile at the nice foto of clean floors and table tops, we look twice. What do we see? Curtains—and drapes, with easy chairs around, and bookshelves. In other words, the foreign amateur's "shack" is his den, a place where he can relax, converse with the world in comfort.

They do not have to keep their face turned toward the dial and key to shut out the unpleasant visions of untidy floors, bare walls, or equipment that would give envy to the city junk man, or cause a guilty feeling to run up and down the spine for not cleaning-up months ago.

An example of foreign comfort is VK5FB's shack. Note the drapes. But first a little resume or word picture from the start to finish.

Approaching from a distance, a tall spire punching a hole into the sky, stands out like the proverbial telephone booth in a fog. Located in a plainland in South Australia, where the heat would make the great San Joaquin Valley feel like Alaska, is VK5FB. A nice 104-foot lattice mast with a small white cottage gives rise to the feeling that a "ham shack" is near. Upon arrival at this shack, there is wonder at how anyone can stand up in it, or cause one to think the owner a midget, for the roof slopes from about seven feet, at the gable, to about four feet at the

VK5FB—very PB! Here is a VK station that IS a station. The pictures show the shack, antenna, sound truck and interior of the coziest operating room we have ever seen.

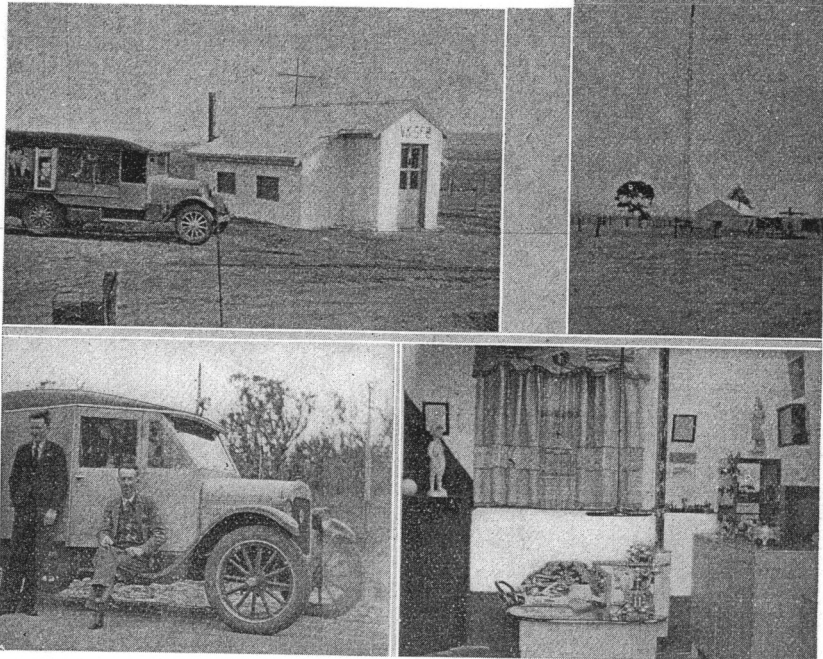

eaves. Then comes the surprise. Upon opening the door, steps lead down to the floor that is four feet below the surface level. And the reason is—comfort! Comfort from heat. The first thing that strikes the eye is the operating position directly in front, with a neatly draped window further back. One immediately looks for the YL operator but from a movement under a smoke screen old VK5FB pulls himself out from what appears to be the softest and easiest chair in the world. He was merely relaxing and thinking in comfort. Everything is neat and clean, causing one to want to walk on his toes. There are soft rugs on the floor. What a shock, after the usual high lifting steps and tension caused by an expected tripping over a junk pile. It takes minutes, after sitting in the soft easy chair, to realize that the place you are visiting is a ham shack.

The operating position is in the center, with everything right in front of you. It is really an operating position, for everything can be controlled from it without the slightest over-reaching movement.

VK5FB is a sound motion picture operator, and travels most of the time. It is quite possible that some of his company's pictures will arrive in this country, showing the travel pictures that he has taken, and the dope on the London-to-Melbourne air race. He travels all over Australia by car, plane, boat and even horseback. One can readily see why his shack is a place of comfort, after returning from his strenuous travels into the back country.

The fotos verify the above statements. Let's take a lesson from him.

## W6GCS—C. C. Lary, Visalia, Calif.

HERE is an example of beautiful construction work for a radio amateur transmitter. W6GCS, C. C. Lary, of Visalia, California, is the builder. The large photograph shows his entire station. The operating table occupies a floor space of only 2½ x 3½ feet, which was all the space allowed for the ham shack by Lary's YF, who is the former XYL, W6GEV.

Lary is one of amateur radio's real old-timers. The small photograph shows the old boy with his grandson. The grandson, by the way, is Lynford Lawlor Lary, the young sprout son of Lyn Lary, former star player on the Oakland baseball club. Lyn went with the Yankees in 1929 and is now with the Washington club. The mother of the young sprout is the former Mary Lawlor of stage and screen fame. Grandpop Lary, W6GCS, is in charge of the Southern Pacific's railway station at Visalia, California.

His transmitter consists of a pair of 245s in push-pull driving a pair of 210s in push-pull in the buffer stage and these, in turn, drive the two W.E.242s in the final amplifier. The transmitter's input is 300 watts. Operation is on 80 meters. Eleven Weston meters are mounted on the transmitter panel.

The receiving portion consists of a frequency meter (extreme left) and an FBX receiver (ex-

treme right). The loudspeaker is built into the wall of the radio room. The control box in the center of the photo, between the frequency meter

and the receiver, contains the necessary switching arrangement for the power supplies, etc. A clock is mounted in the center of the control box. The power supplies are mounted in a cabinet under the operating desk. A protective grill-work enables the operator to keep his feet warm while QCO-ing, yet prevents him from resting his feet on the filter condensers or transformers, so as to insure long life to the operator.

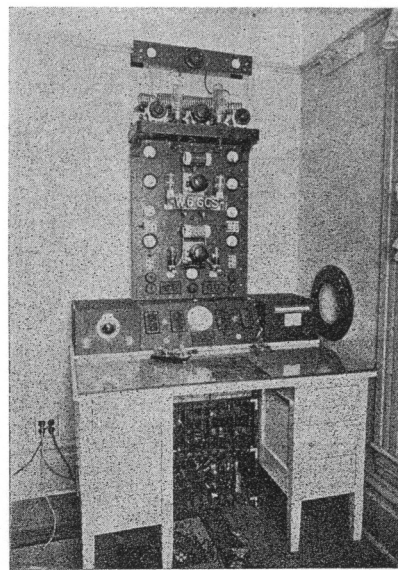
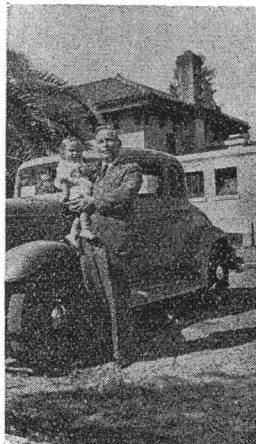

# Transformer and Choke Design for Mercury-Arc Rectifiers

• The mercury arc rectifier, although rarely seen in an amateur station, has been widely used in various commercial applications since 1905. Its theory of operation is almost identical with that of the conventional hot-cathode mercury vapor rectifier, except that a different source of electrons is used. Instead of boiling the electrons out of an oxide coated filament or cathode by means of heat, the electrons are boiled out of a pool of mercury by means of the "cathode spot" when an arc is used.

The cathode spot is maintained by the passage of at least 3 amperes of arc current itself, so that a "keep alive" circuit must be provided to supply this 3 amperes of heating current.

Present-day mercury arc tubes are practically the same as the first tubes made in 1905. In general, the older tubes had several disadvantages for amateur use. They were

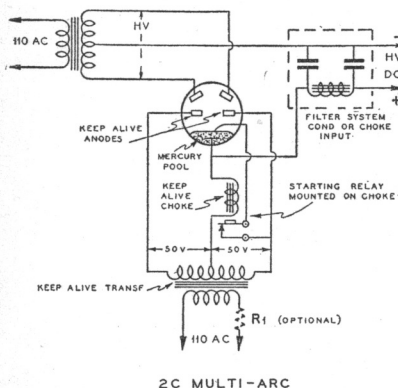

Circuit diagram showing simplicity of Multi-Arc starting, Keep-Alive Circuit and filter supply.

usually made of soft glass, which necessitated an oil cooling tank. The keep alive electrodes were not designed to keep the arc alive, but merely for the purpose of starting the arc. Another disadvantage of conventional mercury arc tubes is that the tube must be rocked, mechanically, in order to start the arc. These disadvantages have been overcome in the new series of Multi-Arc rectifiers. The glass envelope is made of Pyrex, the keep alive arms are designed solely for that purpose, and a highly effective automatic electrical starter has been provided.

The advantage of the use of a mercury arc is that it is practically impossible to overload it or wear it out. Its first cost is its last cost. Even the smaller arcs will pass 10 amperes at 10,000 volts without difficulty, and 10,000 hours of life is the minimum that can be expected.

The cost of a small mercury arc is ap-

★  
By  
GEORGE  
BECKER

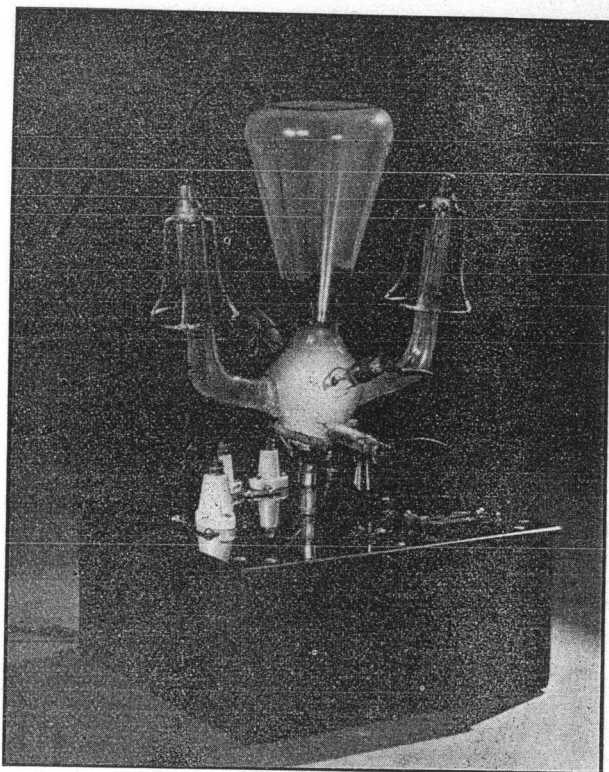

The new Multi-Arc with automatic self-starting mechanism. It is not necessary to tilt this arc; it starts by means of an automatic switch inside the tube.

proximately equal to one of the newer 10,000 volt 2½ amp. hot cathode rectifier tubes.

No filament transformers are required when an arc is used, but a certain amount of starting and keep alive equipment is necessary, as shown in the circuit diagram. Complete details for constructing this simple equipment follow:

## Construction of Keep-Alive Transformer

It is necessary to maintain a current of from 3 to 4 amperes through any mercury arc rectifier, thus the lowest possible voltage that can be used to keep the arc alive will give the most economical service. Knowing the voltage drop in the tube to be about 15 volts and the voltage drop in the choke equal to  $I^2R$ , plus some drop in the transformer secondary, an average value of about 50 volts per anode is a reasonable amount and gives ease of starting. This means that the transformer must have a 100-volt secondary, center-tapped and designed to carry 3 or 4 amperes. Since current flows in each half of the secondary alternately, the average current is 1.5 or 2 amperes, and thus the same size wire can be used for both primary and secondary. A core, one inch by one inch, is satisfactory. There will be a voltage about 0.2 volt per turn, so 550 turns on the primary and approximately 550 turns on the secondary are required. The extra 50 turns should be wound on the secondary to provide for regulation of the transformer; regulation in a transformer of this design is not very good. For use in the average amateur's transmitter where the negative high voltage is grounded, the entire keep-alive must be insulated for the peak plate voltage.

A choke is needed to prevent the current in the arc circuit from reaching zero and extinguishing the cathode spot. The larger the choke the smoother the arc will run and the easier the tube starts when cold. The choke must have sufficient resistance to drop

the 10 volts or so left after the tube drop and transformer drop are counted out. This choke will eliminate the use of resistance  $R$  either in the center tap or the 110-volt primary. This choke requires a considerable amount of wire and increases the cost of the choke, so it is cheaper to use a less efficient choke and absorb some power in a resistance. The use of the resistance also enables the keep-alive current to be cut to the minimum. The keep-alive voltage is not critical; anything from 40 to 250 volts or more can be used.

After the tube starts it is necessary to isolate the starting electrode because it is connected to one anode and therefore becomes an anode momentarily—see diagram. The easiest way to accomplish this is to mount an armature on the choke so that the magnetism of the choke operates the armature and opens the circuit. This is all that is necessary for the entire keep-alive circuit.

The core of the transformer is made of silicon steel laminations one inch wide. Cut enough pieces ¾ inches long to make two stacks 1 inch high when compressed, and enough pieces 2½ inches long for 2 more stacks. The two long stacks should be laid so that the alternate pieces overlap one inch. When completed, the stacks should be compressed tightly and taped with ordinary friction tape.

Taking one stack for the primary leg, wrap two layers of empire cloth (0.01) and wind on the wire, 550 turns of No. 18 S.C.E. Wind 60 turns for the first layer. This layer will be 3 3/16 inches long, leaving equal spaces at each end of about ¼ inch. Be sure the empire cloth is longer than the core inside measurement so that it protrudes about ¼ inch beyond the first and last turn. By winding layers on, and building back each layer so as to form a self-sustaining winding, the tenth layer will have 60 turns and should come out even with 550 turns total

(Continued on page 28)



# A Neat, Inexpensive Transmitter for Beginners

By ALEX G. HELLER\*

Experienced short-wave receiver constructors, who have been using aluminum, copper and steel chassis for many years, seem to forget what they have learned about shielding and rigid mechanical construction when they attempt to build their first transmitters. Instead of applying the ideas they have acquired during long and usually expensive experimentation, they take apart packing cases or rob the kitchen for baseboards.

It is not necessary to have machine tools in order to work with metal chassis. Parts manufacturers have recognized the need for ready-formed blank chassis, and have made them available in numerous sizes and shapes.

tionary claims are made for the circuit, as shown in Fig. 1; it is recommended more for its utter dependability and effectiveness than for any novelty.

This transmitter is intended for two-band operation with a single crystal. The latter should be selected with a frequency value between 3500 and 3650 KC, so that the second harmonic falls within the limits of the 7000-7300 KC ("40 meter") band. For straight "80 meter" service, the socket for coil L1 is short-circuited; the 30-turn coil

off L2 for amplification by V2, the 210, the plate tank L3-C3 again being tuned to the crystal frequency. The plate-grid capacity of V2 is effectively neutralized by the out-of-phase voltage developed across the bottom of the plate tank coil L3 and impressed on the grid through the neutralizing condenser C6.

For "40 meter" operation, the same crystal is left in, but now the 16-turn coil is used at L1, the 19-turn coil at L2 and the 14-turn coil at L3. The 59 now acts as the well known "Tri-Tet," with the screen-cathode circuit responding to the second harmonic of the crystal, and the plate-cathode circuit further amplifying it, so that a strong 40-meter impulse is available for driving the 210 amplifier, also tuned to the harmonic frequency. This sounds complicated, but the transmitter can be tuned to one frequency and then shifted and retuned to the other frequency in less time than it takes to read this description of the circuit!

The antenna tuning unit is of the new impedance matching type, and permits almost any exposed piece of wire, regardless of its length, to be used as a radiator. Of course, the better the aerial the better the DX, and all the principles of good antenna construction should be followed.

It will be noted that the antenna unit is mounted on a wooden board. This was done as a matter of temporary convenience, as it is planned to combine L4, C4 and C5 with a 50-watt power amplifier that eventually will follow the 210.

The mechanical arrangement of the parts on the chassis is made evident in the photographs. L1, V1, L2, V2 and L3 are strung along the center line of the top. Holes for the four sockets are cut with a circle cutter, which is worth its weight in crystals. The large L3 form is fitted with GR type plugs and fits in feed-through type standoff insulators with jack ends. The crystal fits into a similar pair of standoffs behind and between L1 and V1. In a line with the crystal are the two single closed circuit jacks

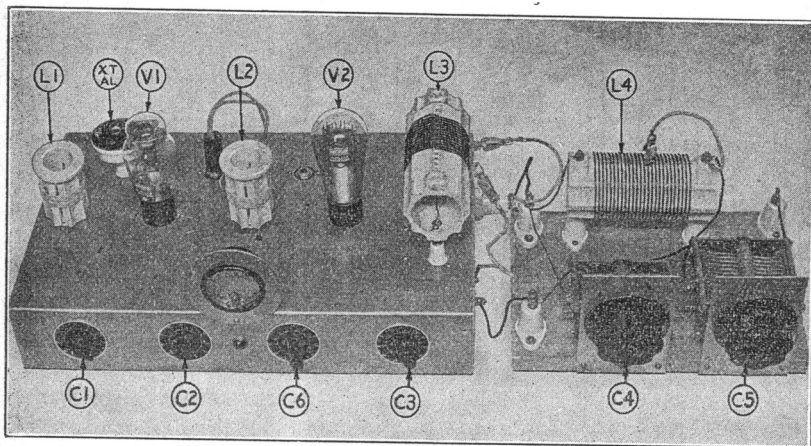

59 Tri-Tet Oscillator, 210 Amplifier and PI Network Antenna Coupler

Admittedly, it is a mean job to cut, bend and fasten chassis out of plain flat sheet metal and have the finished pan look like something more symmetrical than a pretzel; the ready formed chassis now available save all this work. Of course, it is easy enough to drill holes with an ordinary hand drill or brace—tools every radio constructor owns.

For the convenience of amateurs, and to show what can be done in the way of a "beginner's" transmitter that looks and works well, an elementary crystal-controlled oscillator-amplifier outfit composed almost entirely of inexpensive receiving parts was put together. To any experimenter who has assembled a receiver of more than three tubes this modern 1935 transmitter will be child's play.

A ready-formed Electralloy base measuring 17 by 10 by 3 inches was selected. Incidentally, amateurs are beginning to appreciate this new material, which bends easily without cracking, solders readily with ordinary materials, is non-magnetic and has a resistance between that of copper and aluminum. Electralloy is cheaper than aluminum and is now available in sheets, formed chassis and in special shapes to order. It is very easy on cutting tools; in fact, it handles almost like hard wood.

To keep down the cost of the required power equipment for the transmitter, the popular and reliable type 210 tube was selected as the amplifier, with a type 59 as the oscillator-driver. Crystal control is, of course, a requisite. With perfectly good crystals offered at low prices, and conditions on the amateur bands being what they are, it is positively sinful for a beginner to use less reliable self-excited rigs. No revolu-

used at L2 and the 25-turn coil at L3 (See coil data table). Tube V1, the 59, then acts as a straight oscillator, the plate tank circuit L2-C2 being tuned to the crystal frequency (or rather a trifle off it, for the sake of stability). The output of this stage is tapped

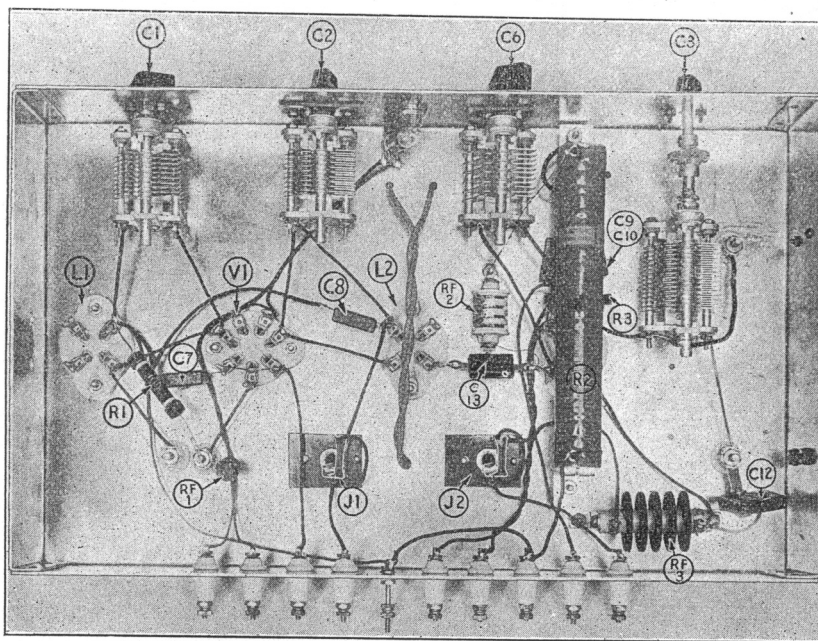

Oscillator and Amplifier Tuning Condensers, as well as the Neutralizing Condenser are all beneath the chassis.

\* Chief Engineer, Insuline Corporation of America.

J1 and J2, mounted on little insulating panels of bakelite to keep them off the chassis.

The four variable condensers fit very nicely along the front 3-inch wall, being controlled by the new pointer type knobs. C1 may be mounted directly on the chassis, but the rotors of C2, C3 and C6 are all above ground potential and must be insulated from the chassis, which forms the B minus and ground return. The photo of the underside shows C2 and C6 mounted on small bakelite plates, but an easier method is to support the condensers on brass collars with screws passing through the top of the chassis into threaded holes already in the framework, and to connect the knob to the shaft by means of a small insulated flexible coupling. The amplifier tank condenser C3, on the extreme right, is supported in this fashion.

The arrangement of the other parts on the underside follows their natural circuit positions almost exactly. In the picture, R3 and C8-C10 are concealed by the grid leak R2. The latter, by the way, must be a good non-inductive unit, as specified in the list of parts.

All power leads are brought out to small feed-through standoff insulators along the back edge. The uninsulated screw is B minus. The wiring is exceedingly simple and should not take more than about an hour and a half.

While individual milliammeters for the oscillator and amplifier plate circuits are highly desirable, a single 0-100 ma. meter serves the purpose nicely. The plug and jack arrangement allows quick shifting during the tuning process. If the builder can afford two meters, one can be placed nicely between C1 and C2 and the other between C6 and C3.

The tap on the L3 coils is grounded by means of a clip on the end of a short piece of flexible wire, the other end of which is simply grounded to the chassis by a nut and bolt. The other tap on L3, which runs to the antenna unit, is a matter of experiment. The best spot is about half way between the top of the coil and the fixed grounded tap.

It is an excellent idea to use a small receiver type power supply for the oscillator stage and a separate heavy-duty pack for the amplifier. Even the very smallest pack will be all right, as the drain is only about 15 ma. The separate pack gives the oscillator absolutely rockbound steadiness, altogether unaffected by keying of the amplifier. The only important point to be watched is the output voltages, which should be adjusted carefully to 100 and 300, for the screen and plate, respectively, by means of a divider with sliding taps.

For the amplifier, the power pack must be capable of furnishing up to 100 ma. at 450 volts. Two 281s or a single 5Z3 may be used for rectification. The power transformer should develop 600 volts across each side of the center tap. A separate little filament lighting transformer is desirable for the 210 filament. The constructor has a wide variety of power units to choose from. An adjustable divider is again desirable. Although the 210 will handle 50 watts of plate power (not without some objection in the form of heat!), longer tube life and better signals will result from more sensible operation, at lower values.

At the operating table, next to the key, it is a good idea to provide the three switches S1, S2 and S3. The first two break the line circuits of the power packs, the last the B negative to the oscillator. Since the oscillator is left running and all keying is done in the amplifier stage, the receiver will be blocked by the oscillator output during reception periods unless the plate supply is interrupted. It is much better to leave the filament hot and to cut the plate circuit than to turn off the whole power supply.

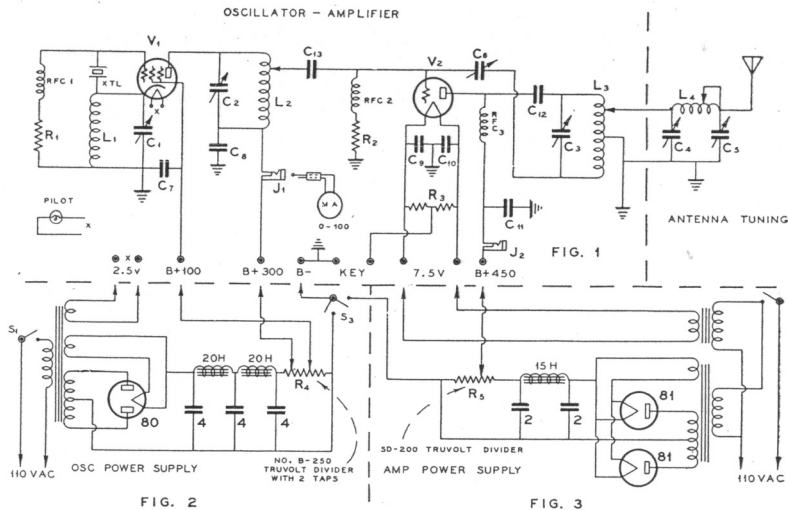

#### PARTS LIST

- C1, C2, C3—140 mmf. midget condensers, with rotors insulated from frame (Insuline No. 104)
- C4—500 mmf. variable condenser (Cardwell No. 123B)
- C5—220 mmf. variable condenser (Cardwell No. 164B)
- C6—50 mmf. double spaced neutralizing condenser (Insuline No. 121)
- C6, C7, C8, C9, C10, C11—.005 mf. mica condensers, 1000 volt test (Cornell-Dubilier Type 3)
- C12—.005 mf. mica, 2500 volt rating (Cornell-Dubilier Type 4)
- C-13—.00025 mf. mica, 1000 volt test (Cornell-Dubilier Type 3)
- L1, L2—Wound as specified on 1 3/4-in. forms (Insuline No. 952)
- L3, L4—Wound as specified on 2 1/4-in. forms (Insuline No. 2650)
- R1—50,000-ohm, 2-watt grid leak (IRC)
- R2—10,000-ohm non-inductive grid leak, 100 watts rating (Electrad)
- R4—25,000-ohm Truvolt divider, with 2 taps (Electrad No. B-250)
- R5—20,000-ohm Truvolt divider, one tap (Electrad No. SD-200)
- RF1, RF2—8-mh. chokes (Insuline No. 279)
- RF3—5-mh. heavy duty choke (Insuline No. 278)
- J1, J2—Single closed circuit jacks (Insuline No. 363), with phone plug (Insuline No. 24)
- 0-100 ma. milliammeter, small size (Weston)
- Crystal holder (Insuline No. 414)
- 4—Plug-in type feed through insulators (Insuline No. 2320) for crystal holder and L3.
- 10—Small feed through stand-off insulators, for power connections (Insuline No. 2305)
- 6—Medium stand-off insulators, for antenna unit and L4 (Insuline No. 2302)
- 3—Four-prong sockets, for L1, L2, V2 (Insuline No. 2600)
- 1—Seven-prong socket, for V1 (Insuline No. 2603)
- 4—Dials and pointer knobs (Insuline No. 2217)
- 1—Pilot light with 2 1/2-volt bulb
- 1—10x17x3-inch Electrolytic base (Insuline No. 1517)
- 1—Board 7x11 inches for antenna unit
- V1—Type 69 Raytheon tube
- V2—Type 210 Raytheon tube
- 3—Small insulating couplings (Insuline No. 2100)

Tuning the transmitter is simple. The regular receiver can serve as a monitor if the receiving aerial is disconnected and the volume control backed down. For operation on the crystal frequency, short out the L1 socket, as previously instructed, and follow the coil data table for the coil combination. Turn on both packs, but be sure to leave the key up, so that no current is applied to the plate of V2.

Turn C6 and C3 to zero. Tune C2 for minimum plate current; a critical spot will be found, but the condenser should be set for a little lower capacity than the minimum requires. Touch a neon tube to the top of L3 and tune C3 for maximum glow. Now turn in C6 slowly (making slight readjustment on C2 to keep the oscillator stable) and rock C3 back and forth until the glow disappears and cannot be obtained with any setting of C3. The amplifier tube is then neutralized. Switch the milliammeter to V2, press the key (with the aerial off) and tune C3 sharply for minimum plate current. The signal in the monitor receiver will be tre-

mendously stronger with the key down than with it up.

To "double" the crystal frequency, follow the coil set-up for "40 meters." Tune C1 and C2 for minimum V1 plate current. The tuning of C1 will be very broad, but C2 fairly sharp. Tune C3 for minimum V2 plate current. Re-neutralizing probably will not be necessary if the coils are wound carefully as specified.

To make the antenna take "power," clip onto L3 experimentally, and also try about half of L4. Rotating C4 rapidly, with C5 about half in, should cause a dip in V2 plate current. DO NOT change any adjustment on the transmitter itself. Adjust C5, juggling it against C4, until the amplifier tube is safely loaded and an antenna ammeter or flashlight lamp shows maximum reading. A 2.5-volt pilot light gives a good, brilliant indication with the plate load about 65 milliamps at 450 volts.

Of course, untuned transmission lines or tuned Zepp feeders may also be used.

The transmitter described is no mere laboratory job, but is giving fine service on the ham bands at stations W2GLP and W2DJJ. It has been tested thoroughly and can be built with confidence by anyone entering amateur radio.

#### COIL DATA

For 40 Meters:

- L1—16 turns No. 20 D.C.C.
- L2—19 turns No. 20 D.C.C. tapped at 14th turn
- L3—14 turns No. 14 bare or tinned

For 80 Meters:

- L2—30 turns No. 20 D.C.C. tapped at 20th turn
- L3—25 turns No. 14 bare or tinned

For Both Bands:

- L4—25 turns No. 14 bare or tinned, with clip
- L1, L2—Use 4-prong Insulex receiving forms, 1 3/4-inch diameter
- L3, L4—Use threaded Insulex transmitting forms, 2 1/2-inch diameter

#### Amateur Radio Station W6USA at The California Pacific International Exposition

A. Wayne Prather (W6GWY), Business Manager and Owner.  
 E. F. Kiernan (W6EEO), Designer, Builder, Licensee, and Owner.  
 H. K. Breedlove (W6JRM), Station Manager and Owner.  
 Ray Dobler (W6BHF), Chief Operator.  
 Amateur Radio Station W6USA at the California Pacific International Exposition, beginning May 29, 1933, and running for a period of approximately one year, will be built and operated in strict accordance with the Federal Communication Commission's regulations as an example of amateur radio activity.  
 Communications regarding the station should be addressed to: A. Wayne Prather, 4741 36th St., San Diego, California.

# Using a 32 Tube in an Electron-Coupled Frequency Meter

By L. B. PETERY, W8KZI

• The suggestion of using a frequency meter with batteries as the source of power will probably bring gasps of horror from the majority of amateurs. Thanks to the air cell type tubes, such a meter can be made economically, and operated economically. Many frequency meters using AC tubes require a built-in power supply; the rectifier, filter and transformer imposing an additional strain on already strained pocketbooks.

The writer became interested in developing the 32 tube in an electron-coupled frequency meter. An early discovery was that the grid leak and condenser could be eliminated, and the battery voltage dropped to 22½, the current being limited by means of resistors in the screen grid and plate circuits.

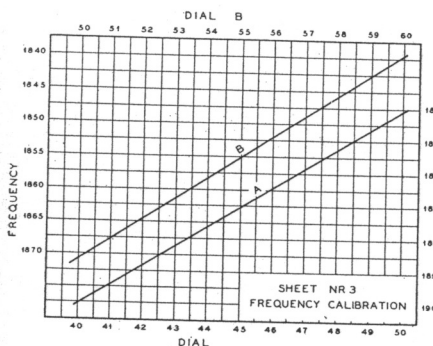

Frequency calibration chart.

uits. An optional value of ¾ milliampere in each circuit was chosen, as this seemed to give the greatest output with lowest battery drain—lower currents causing noticeable drop in output, while higher currents made no appreciable difference. The plate resistor also acts as a coupling resistor. The values used are 5,000 ohms in the screen grid circuit, and 20,000 ohms in the plate circuit.

The second fact of interest was that there was no heating of the tube due to the filament. This, naturally, is apparent on consideration, and introduces the feature that the meter is ready to use as soon as the switch is snapped on. Thus, the battery drain is further lowered, as the meter need not be run except when used. There is no need to wait for the tube to warm before accurate readings can be taken. The question of temperature correction to care for ambient temperatures was settled by incorporating on the panel a small thermometer from the dime store, the watchcase type, built like a flush type meter, and secured to the panel by a clamping ring. A two-plate midget condenser with adjustable spacing to give full range over the maximum temperature range, has its dial calibrated to temperature. This calibration shows a branching of the high and low frequency settings for temperatures more than 20 degrees from the calibrating temperature.

The oscillator circuit proved to be by no means tricky. Every combination except Colpits (because no suitable condenser was available) was tried, and none of these circuits failed to oscillate readily and show good output. Figure 1 shows the circuit, with the filament fed through RF chokes, and coupled to the coil through two 200 mmfd condensers. One of these condensers can be left out with no loss

to the operation of the meter, and the value is not critical, 75 to 250 mmfd condensers working equally as well. The chokes consist of 75 turns No. 30 wire wound on bobbin forms salvaged from an old broadcast receiver. The coil L, the frequency condenser C1, and tank condenser C2 determine the frequency band and coverage of the meter. The filament tap is not critical, from ¼ to ½ the total number of turns from ground. Perhaps the best way to get the coil adjusted is to wind on several extra turns, and tapping the filament ¼ the total from ground. The grid end of the coil should be convenient for adjusting the number of turns. Dope the coils with clear lacquer which binds the wire securely. After the lacquer has dried, the wire can be brought directly to a soldering lug without threading the wire through holes in the coil form, a common method used to hold the wire. The meter completely built, and the coil on the approximate band, the range may be tested with the meter in the cabinet. Adjusting the coil and condenser values is a tedious job not limited to this type of meter. Wire is taken off the coil a turn at a time and the ion batteries could be used for the filament supply with perhaps only a little loss in accuracy, the constancy of operating conditions being the determining factor. Where the meter is to be used from a battery subjected to varying loads, or different lines run from the battery or associated equipment at

the panel so the voltage may be easily regulated, yet not subject to accidental variation.

It was found that when the batteries were placed in the shielded cabinet, the meter produced a howl which disappeared when the batteries were removed from the cabinet. This howl was apparently caused by the filament chokes not completely eliminating the radio frequency from the filament batteries, and the additional capacity of batteries to shield was enough to cause unstable operation. This was stopped by by-passing from the point A (Fig. 1) to ground with a 1 mfd condenser, i.e., by-passing the ungrounded filament lead on the battery side of the radio frequency choke to ground. Since no convenient location for the by-pass condenser existed in the meter as conducted, the expedient of simply reversing the filament batteries was tried successfully. A check of the screen grid and plate currents

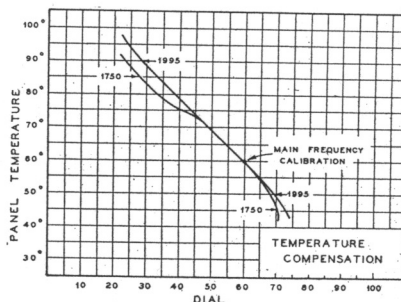

Temperature compensation chart.

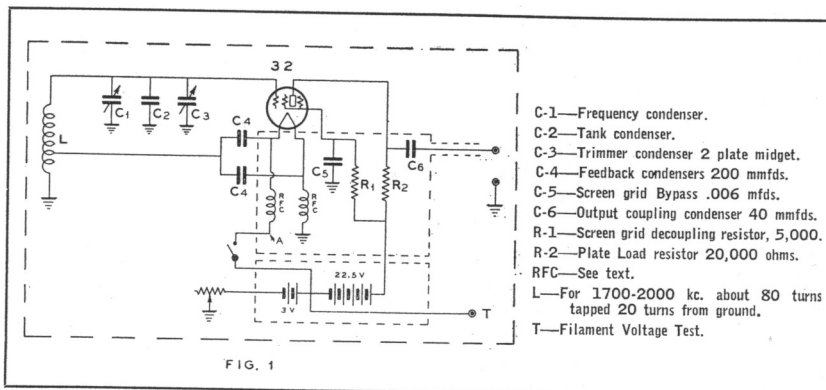

FIG. 1

frequency range is approximated. Increasing or decreasing the tank condenser may be necessary to get the desired range, which means the coil must be readjusted. Since constructional methods differ so widely, no exact values for coil and condensers found

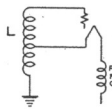

FIG. 2

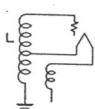

FIG. 3

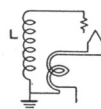

FIG. 4

by one person would be the values required by another constructor.

The batteries should be kept in a separate shielded compartment, and so arranged to be held securely in place. The regular standard times, an element of error can be expected. The rheostat has a lock dial on

showed no change from the opposite filament battery polarity, and no change in operation of the meter could be noticed.

The output lead was first tried in shielded braid, but the distributed capacity caused a high loss of output, so this was replaced by ¼-inch copper tubing, and No. 24 wire threaded through on beads of rubber taken from ignition cable. The coupling condenser is a 40 mmfd midget. The output can be shorted with little change of frequency. A larger condenser is not recommended, and a much smaller one may be used if the meter is to be used on the three lower frequency bands. Use an insulated wire hooked around the output post for these bands, and directly to the post for the high frequency measurements.

Figures 2, 3 and 4 show some other oscillator circuits which worked very well, though from the frequency meter viewpoint, (Continued on page 20)

# Putting the 802 to Work

• While the new 802 RF Pentode is not a particularly economical tube for phone use, nevertheless it has its advantages when used in a simple transmitter. Such a transmitter was built for the purpose of testing the possibilities of suppressor-grid modulation.

The transmitter consists of an 802, operating as an ordinary pentode crystal oscillator with 550 volts on the plate. It is modulated by a single 6C6 operating as a triode and driven, in turn, by a single-button microphone. Fig. 1 shows the circuit diagram and Fig. 2 shows the suppressor modulation characteristics of the 802 when used with 500 volts on the plate. The circuit is fairly conventional, although there are one or two unusual features.

The first feature is the use of a 15 mmf. feed-back condenser tied directly between plate and control grid. This condenser is necessary for the purpose of producing oscillation, especially at 160 meters, because the

used, but due to differences in resistors and plate supplies it is advisable to make the screen voltage adjustable. A high-resistance voltmeter should be used when adjusting the screen voltage so that it will read exactly 200 volts.

The cathode is grounded, but B minus is not. The B minus lead from the power supply finds its way to ground through a resistance of approximately 900 ohms. The drop across this resistance provides the negative bias for the suppressor grid and the resistance should be so adjusted that the voltage measured between the B minus point and ground is exactly 45 volts.

Resistance coupling is used to couple the audio frequency output of the 6C6 triode to the suppressor of the 802. This method of coupling is used for two reasons: (1) it saves the cost of an audio transformer; (2) the use of a 1/4 megohm plate load resistor on the 6C6 allows sufficient voltage drop so that the B power for the 6C6 can be obtained from the 550 volt power supply which feeds the 802.

The DC return of the suppressor grid on the 802 to the B minus point is through an-

(Continued on page 28)

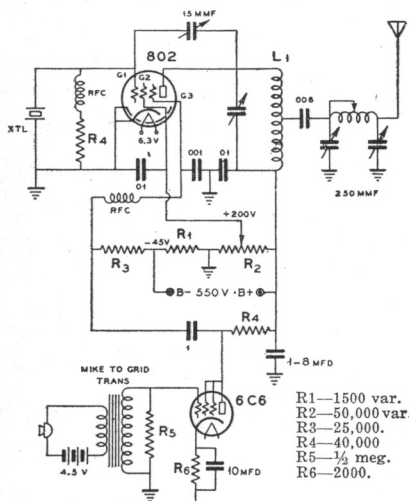

FIG. 1

SUPPRESSOR MODULATION CHARACTERISTICS

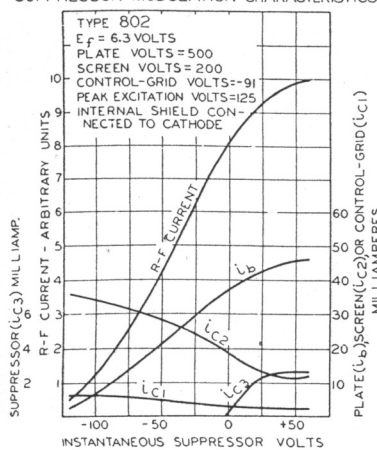

FIG. 2

802 has extremely good internal shielding. This condenser should be adjusted while listening-in on a receiver or monitor, so that the best note can be obtained.

The Collins coupler is also conventional and the plate tank should be tuned to resonance with the Collins coupler disconnected. The screen voltage of 200 volts is supplied from a voltage divider which has a sliding tap. Two fixed resistors could be

used, but due to differences in resistors and plate supplies it is advisable to make the screen voltage adjustable. A high-resistance voltmeter should be used when adjusting the screen voltage so that it will read exactly 200 volts.

The DC return of the suppressor grid on the 802 to the B minus point is through an-

## Electron-Coupled Frequency Meter

(Continued from page 19)

Figure 2 is the best as it introduces the fewest extras into the tuning circuit. Figures 3 and 4 show a partial and complete inductive feedback. The filament chokes as used in circuits shown in Figures 1 and 2 are not at all critical, on the 1750 KC band 20 turns on a 1/2-inch form worked very well. Any reasonably good choke will work as long as the current capacity is sufficient, and the resistance is not enough to drop the filament voltage below 2, bearing in mind to allow a margin for voltage drop in batteries. In Fig. 2, the number of turns on the ungrounded filament lead should be approximately the same as the portion of the coil between tap and ground. In Figure 3 the filament turns number about 1/4 the total of the coil. In trying this circuit, a twisted pair of No. 30 DCC wire was made and wound as if it were one wire. The direction of winding is the same as the winding of the grid coil in these three circuits (Figures 2, 3 and 4).

Construction advice is to use plenty of screws, bolts and solder, and make everything solid. This meter will put out plenty signal on 60 megacycles with the fundamental on 2 megacycles. At the latter frequency some mechanical defects might not be noticeable, but would wobble a signal all over the dial at the former frequency. Also, it is a good idea to bear in mind that temperature changes will cause mechanical movement in all three directions, and the relations of these movements to other parts should be considered, as it is possible to have a leverage on some part to displace it far more than it should, thus exaggerating the frequency change due to ambient temperatures.

The meter may be calculated in a number of ways. One of the best is to use an oscillator on the broadcast band. If the temperature compensation feature is to be used, this must be set at some optional reading, such as half scale for the expected average room temperature and making sure the meter is at this temperature. The task of calibrating can then go on, beating the oscillator with a broadcast station of known frequency, picking off the harmonic in the frequency meter range. Many more calibrating points can be obtained by taking harmonics from

the frequency meter and the higher harmonics from the oscillator beating with a broadcast station. For example, the oscillator tuned to WLW on 700 KC will give harmonics at 2100 and 3500 KC. The second harmonic from the frequency meter will beat with the 3500 KC harmonic to give 1750 KC on the frequency meter.

The temperature calibration was made by allowing the meter to settle to a temperature other than normal, then with the main dial set for some frequency for which there is a known frequency available, the compensating condenser is adjusted for zero beat, the dial reading of the compensating condenser and the temperature being used to chart another curve. For example, at 60 degrees temperature, 1750 KC was at 90.0 on the main dial, with the trimmer or compensator set at 60. After a 10-degree temperature change, the main dial was carefully kept at 90.0, and the trimmer changed to, say 49.60 temperature, 60 dial would make the first point in the temperature calibration, the next would be 50 (perhaps 70) temperature and 49 dial. At 2000 KC, the trimmer might be 48 or some other slightly different value. As mentioned before, the temperature compensation holds true over only a small variation. In making the temperature calibration, the meter must be at the temperature all over and inside, otherwise there is little use to make or take the trouble to calibrate it as to temperature. Of course, when more than ordinary accuracy is desired, the meter should be checked against reliable signals, such as are furnished by the broadcast stations. In making the calibration curves, use several sheets of 8-11 inch graph paper. Two curves are made on each sheet, the bottom and right side being the dial from 10 to 20 and the corresponding frequency range, respectively. The next page having dial 20 to 30, that respective frequency range, and so forth. Graph paper is usually made with the fifth lines being slightly heavier, two of these are used for each unit dial reading. Since the meter dial could be read in tenths, each small square is consequently one of these 1/10th readings. The dial used is 0-100, so this gives five sheets, or six counting the temperature calibration sheet. The frequency divisions naturally depend on the range of the meter, so a little figuring may be required to get the two curves on one sheet. There seems to be little need to try to measure closer than 1/2 or 1/4 KC.

In the measuring of the ultra high frequencies where the order of harmonic is unknown, the meter is tuned to give zero beat with the unknown frequency, and the meter frequency noted. The meter dial is then turned (either way) until another beat is secured, and meter frequency is again noted from this second known frequency on order of harmonic beating with the unknown frequency is secured which is one higher or one lower than the order of harmonic from the first known frequency. That is, the two adjacent frequencies must be used to determine the unknown frequency by the following formula:

$$\frac{F_1 F_2}{F_1 - F_2} = F_X$$

That is, the unknown frequency will be the product of the two known adjacent frequencies, harmonics of which beat with the unknown frequency, divided by the difference of the two frequencies.

The combination of a detector with a frequency meter is popular among amateur stations today. There is no reason why a detector tube could not be incorporated into a frequency meter-monitor. If the detector and associated apparatus draw very high plate current, a separate or external "B" battery should be used.

# Amateur News

## The Amateur's Legion of Honor

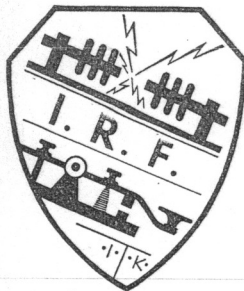

This department is edited by the President of the International Radio Fraternity, J. Richard Meloan (Jo) radio W6CGM-W6ZZGB, KERN. All communications concerning the International Radio Fraternity, as well as inquiries from any amateur as to the Requirements for Membership, should be addressed to I.R.F.

Headquarters, International Radio Fraternity, 715 S. Hope St., Los Angeles, Calif.

## Silver Cup Contest

● IRF has inaugurated a contest open TO ALL AMATEURS, regardless of their radio affiliations, for the best all-around amateur radio station in the world. The home made 210 job has more chance to win than a commercial built 1 kw rig. Originality, neatness, homemade parts, operating ability, DX, traffic, and QSOs are the main requirements of this contest. Send in photos and description of station and yourself, to HQ before March 1st, 1936. Don't forget, the person who wins this cup, KEEPS it forever. A new cup is to be awarded each year. This contest is to be judged by the leading amateurs of North America and the committee will consist of five members. LET'S GO!

## What About 28 MC?

● IRF will give one year's subscription to "RADIO" to the first IRF member who QSOs any 28 MC station over a distance of 2000 miles for the coming 28 MC season in 1935. Somebody is bound to win, so put that flea-power on the air and stick around, because there are 28 MC signals in the air every day and it just remains for someone to pull them down to earth at both ends. Also please note the weather conditions at both ends at time of QSO.

## New Zealand Chapter

● During the past two months Mr. Penton of ZL3AN has been doing a lot of FB work in organization a large group of amateurs into an IRF Chapter. The new Chapter consists of ZL3JR, president; ZL3BJ, secretary-treasurer; ZL3AN, ZL3DK, ZL3BK, membership committee; and ZL3GX, ZL3DB, ZL3AE, Z1JY, ZL3HV, and ZL3DC. Mr. Penton says, "Interest high locally and expect more applicants by our next meeting on December 21st." This New Zealand chapter is setting a fine example for some of our other divisions to strive for.

## Joint WAC Club

Now that WAC is commonplace, it seems fitting that some new method of communication be employed. Consequently a group of amateurs have banded together to form the "Three-Way WAC Club".

Here is how it works—(1) Two amateurs, members of a team, at least 1000 miles apart, work together and make a joint WAC. By this is meant that no contact is counted unless both of the U. S. stations work the foreigner simultaneously, in a 3-way QSO. (2) The same team must continue to work together until joint WAC is accomplished.

(3) A trophy is to be awarded to each member team which succeeds in accomplishing the feat. The first team to make WAC is W8CRA and VP6PZ. The team has worked in three-way QSOs WK2XU, J2GX, G6TT, HC2MO, SU6HL and W6BIP.

W8CRA would like to hear from those who desire to participate in this new Club. Send your letters to Frank Lucas, W8CRA, Canonsburg, Pa.

## What Hams Are Made Of

I.  
I want to tell a story,  
A story I have heard;  
You may think it all a fable,  
But it's gospel—every word.

II.  
The Good Lord took a blacksmith,  
A tinkerer and a Bo,  
Who used to hold a trick job—  
Train dispatching, don't you know.

III.  
A phone lineman and a "central,"  
An "electric" engineer,  
A radio announcer,  
And a man who couldn't hear.

IV.  
And He mixed 'em all together  
With a grain of salt or two,  
And set 'em in the shadows  
To let the mixture brew.

V.  
Then he ran it through a filter,  
And he screened it through a grid;  
He seasoned it with pepper,  
And lifted off the lid.

VI.  
He moulded it and twisted it,  
And shaped it here and there;  
Then took it out and looked at it,  
And set it on a chair.

VII.  
He put some earphones on its head  
And shot it full of juice;  
But when it didn't seem to care,  
The Lord said, "What's the use?"  
"I've tried to make a genius,  
But it won't work worth a d---,"  
So I'll simply let it go at that . . ."  
And called the thing a "Ham."

—THE HAM REPORTER.

Editor, "RADIO":

It is particularly noticeable in foreign contests that stations in the middle of the 7 MC band might, after a CQ, tune their receivers in the center of the band or from either end. Experience has shown that the high frequency end might be the proper one on which to call a particular CQing station near the center, while another DX station might be raised from the opposite end. Some cannot be raised from either end. During the last International contest, an example of good operating was presented by a ZL station which would include in his CQ a statement as to how he would tune his receiver in looking for a reply. Sometimes he would say, "tuning from high frequency end," or perhaps "tuning middle 100 KC."

This certainly looked like a good idea. Instead of calling for several minutes at the wrong frequency, a W station could keep track of the ZL until he was tuning his receiver in the proper part of the band. The statement took several words, of course, and it could be reduced to a "Q" signal.

Also we recently have heard some comment about concentration near 7000 KC and lots of space around 7200 to 7250 KC. Similarly, on 14 MC the edges are well used but the space near the phone band is generally vacant. Few stations at one end of the 14 MC band ever work one at the other end. We are developing a lot of cliques, divided by frequency, and unless we have about four crystals we cannot QSO all of the other hams. And how those at the center ever raise anyone on a call is a mystery unless there are some hams that tune only over the center and miss the edges entirely.

But all this can be repaired easily. Why not devise four "Q" signals to be used for the purpose of indicating how you will start to tune after a CQ. The answering station at the right place will then need to call a few times. Let us suggest the following:

QTW—Will tune up in frequency from low frequency end.  
QTX—Will tune down in frequency from center of band.  
QTY—Will tune up in frequency from center of band.  
QTZ—Will tune down in frequency from high frequency end.

This will cover the stations in the middle portion of the 7 MC and 3.5 MC bands as the station CQing will really tune over most of the center part. Also, it will take care of the 14 MC band near the phone band, or at the opposite end. In fact, it might even make us more "frequency conscious", as well as making out calls more effective, shorter, and causing less QRM.

Elmer H. Conklin, W9FM.

## To Trans-Pacific Traffic Handlers

THOSE amateurs of the United States, Hawaii, Guam and the Philippines who are handling message traffic with China may have seen in QST for January, 1935, (page 24), a note headed, "Foreign Traffic". Lest some amateurs may be misled by the note, enlightenment is necessary. The subject matter has to do with the new amateur restriction adopted by the Madrid convention, which says, "It shall be absolutely forbidden to licensees of amateur stations to transmit internationally communications emanating from third parties. The above provision may be modified by special arrangements between the interested countries". ARRL representatives claimed the last sentence was a great advantage secured by them at Madrid for the amateurs. "RADIO" pointed out that it would be years, if EVER, before any such special arrangements would be made between the United States and any foreign country.

Now along came these ARRL representatives to tell us special traffic arrangements have been made with Canada. (We always did have them with Canada). And that the outlook is excellent for special arrangements with Mexico and Cuba. (With which there never has been any message traffic worth mentioning). And that such arrangements have been refused by seven countries, including China. (With China we have now, and have had for years, a heavy amateur message traffic of great benefit to our citizens). The recital of the refusal of certain employees of the Chinese government may lead some of our traffic men to believe it is now a violation of the regulations to handle a third-party message with that country. Such is not the case; unless or until China ratifies the Madrid treaty we amateurs are just as free to handle messages to and from China as we always have been. China was not interested in the Madrid convention except to the extent of ordering an employee of the Chinese consulate or embassy at Madrid to attend. He was an observer and not versed in radio. The Chinese very wisely avoid the entanglements of these commercial treaties that invariably are breached by their own signatories. In the matter of communications they are especially determined to run their own affairs in their own way. It is the opinion of men familiar with communications in general and those of China in particular that China never will ratify the Madrid treaty and that she will continue to encourage the amateurs of her country to serve her people and our's by the free exchange of third-party messages.

The "special arrangements" sought with other countries would amount to nothing even if made. Spokesmen for the ARRL have announced that they collaborated with our Department of State in framing the requests for such arrangements. The requests are for the handling of "unimportant" messages—meaning messages that would take no business away from commercial companies. Representatives of the ARRL have been agreeable to this limitation. Which is perfectly proper under the circumstances; the circumstances being that employees of the ARRL are bound to regard the interests of the commercial members of the League as well as those of the amateurs. As to just which class of members gets the worst of each attempt to carry water on both shoulders—to serve two opposing employers—anyone is welcome to his own opinion. Mine is that, under the present control of the ARRL, every future case will find the amateur getting the worst of it just as he has in every case in the past.

CLAIR FOSTER, W6HM.

# 5-Watt, 2-Tube Portable Phone

By LINEAR

● Simplicity is one of the essentials for portable radiophone equipment. The advantages of a 5-meter phone transmitter in an automobile are known to all. But 5-meter operation has some major disadvantages; the signals are confined to straight-line paths, and therefore the most satisfactory results are secured in a hilly country.

The development of universal antenna coupler systems by Collins, Jones and others has made possible highly satisfactory results on 80 and 160 meters, even when extremely short antennas are used. It was therefore deemed desirable to test the possibilities of an 8-foot loaded-up to 160 meters and mounted on an automobile.

A transmitter was built in which only two tubes were used. It follows many of the conventional 5-meter practices. A single 42 pentode is used to plate-modulate another 42 as an oscillator. While the modulation of an oscillator is to be deplored because of the inability to obtain complete modulation,

justed to 50 MA by varying the Collins antenna coupler. This represents an input of 15 watts. With 300 volts on the plate of the 42 modulator, its audio output is in the neighborhood of 5 watts. This is sufficient to modulate the oscillator around 85 per cent, which is all that is desirable.

The antenna operates as a grounded quarter-wave, or Marconi-type antenna. The 8-foot rod is mounted on a stand-off insulator secured to the running board on top of a small box which houses the Collins antenna coupler. There is some question as to whether this should be called a Collins coupler or an ordinary loading coil, but the result is the same in either case.

Ordinarily, a quarter-wave antenna for 160-meter operation is about 125 feet long. In the case of this transmitter, only 8 feet of antenna actually radiates, and the remainder of the 125 feet is wound on the loading coil. Perhaps it would be better to say that its "electrical equivalent" was wound on the loading coil. The point is that the whole system is resonant in the 160-meter band and it draws a satisfactory load from the oscillator.

There has recently been considerable improvement in special means of loading quarter-wave antennas for use on 80 and 160 meters and full details will be published in an early issue.

The transmitter is adjusted by disconnecting the single-wire feed line between the plate tank of the oscillator and the Collins antenna coupler, and then tuning the oscillator plate tank to resonance, which is indicated by the point of maximum dip in the plate current milliammeter. The feed line is then clipped on again and the Collins coupler is adjusted until the oscillator draws exactly 50 MA at 300 volts. With a lower plate voltage, a proportionately lower plate current should be drawn. The adjustment of the Collins coupler is quite simple, provided certain fundamentals of the operation of the coupler are observed. The function of the condenser nearest the transmitter is to tune the system to resonance and the function of the condenser nearest the antenna is to vary the loading. After each variation of the load condenser, resonance should be restored by means of the condenser nearest the transmitter.

Do not expect to work the world with this transmitter; the antenna efficiency is quite low. However, if a wire is thrown over a high object, such as a tree, and coupled to the antenna, it will be found that, after retuning the Collins coupler, the transmitting range will be greatly increased. Operation over just as great distances as can be accomplished on 5 meters with an equivalent amount of power and the same location is possible with this transmitter. Under favorable conditions, distances of 400 or 500 miles can be covered. The good feature of this transmitter is that no shadow effect from tall buildings and hills is had on 160 meters.

Users of this transmitter should be cautioned that mobile operation on 160 meters is illegal, but steps are being taken to change this situation.

The use of a modulated self-excited oscillator which is not crystal controlled is absolutely illegal on the 160, 80 and 20-meter phone bands. Therefore the crystal should

not be omitted from the transmitter here described.

At low plate voltages, such as 135 volts, it may be found desirable to add another 42 tube in parallel with the 42 tube now shown as a modulator in order to increase the output. The use of an additional tube is not recommended if more than 200 volts plate voltage is used, because overmodulation will result. When using two 42s in parallel as modulators, the cathode bias resistor for the modulators should be changed from 500 to 250 ohms.

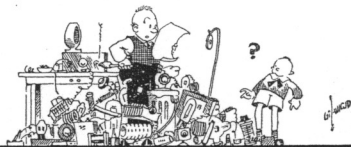

## Ham Hints

By JAYENAY

### The Center-Tap Filament Resistor

● The resistor which is connected across the filament terminals of any transmitting tube is used mainly to balance out the hum and to make both halves of the filament do an equal amount of work in emitting electrons. The DC and RF grid and plate returns should always be connected to the mid-point of this resistance.

The size of the center-tap resistor has been the subject of much controversy, although experience has proven that any value between 50 and 100 ohms is entirely satisfactory. In general, the lower the filament voltage of the tube the lower can be the value of the center-tap resistance, without absorbing too much power from the filament transformer.

When a 50-ohm resistor is connected across the filament terminals of a 10-volt tube, such as a type 211, there will be 200 milliamperes at 10 volts flowing through the resistor, which equals 2 watts. Therefore a 5-watt resistor is usually large enough. If the same 50-ohm resistance is connected across the filament terminals of a 2½-volt tube, it is required to dissipate only 1/8 watt, so that a proportionately smaller wattage rating of the resistor will be satisfactory.

There is absolutely no necessity for the use of by-pass condensers across each half of a 50-ohm center-tap filament resistor because the capacitive reactance of even the largest of the non-inductive types of mica by-pass condensers rarely approaches as low a value as 25 ohms at the amateur frequencies, so that in any case most of the current will flow through the resistor, whether the condenser is used or not.

### Calls Heard At WICNU, Stamford, Connecticut

December 16 to January 14  
15 MC CW

CE7AF, CT3AB, D4BBN, D4BHH, D4BUF, F3SMI, F8EO, F8GG, F8WB, G2BH, G2BM, G2BY, G2PL, G2SX, G2TM, G2UV, G2ZF, G5BD, G5BJ, G5KU, G5ND, G5PJ, G5SR, G5TH, G6BS, G6HP, G6KU, G6LK, G6QB, G6VP, G6WY, G16TK, HB9AQ, HB9J, HPLA, K5AA, K5AC, K5AG, LX1J, NYLAB, NY2AB, ON4AU, ON4CSL, ON4JE, ON4LX, ON4SD, PA0AZ, PA0CE, PA0RP, PA0WR, PA0XF, SU6HL, VP2BX, VP4AA, VP5JB, VP5PZ, X1AM, X1AY, X1W, ZS2A, ZT1R.

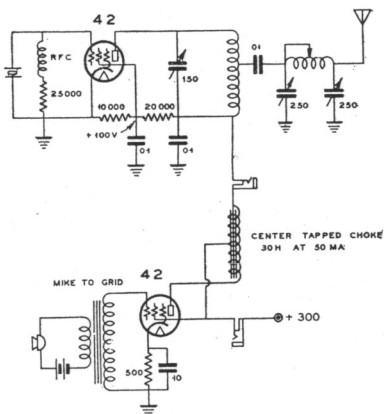

160 meter phone circuit, the acme of simplicity

and because a modulated oscillator is subject to frequency modulation, however, in this case it was felt that the use of crystal control and low power so reduced the area over which such a transmitter can cause unnecessary interference that its use was justified.

The transmitter as shown finally proved to be surprisingly free from frequency modulation and the quality compared very favorably with that of the average 160-meter phone transmitter. The oscillator circuit is largely conventional, except that the grid leak is a little larger than usual, which improves the modulation characteristic and gives better quality. It was also found necessary to obtain the screen voltage from a voltage divider, rather than from a conventional series resistor, also for reasons of modulation linearity.

A center-tap choke was used to couple the modulator to the oscillator. This is an ordinary center-tap choke of about 30 henries at 50 mills. Due to the special connection of this choke, there is very little tendency toward DC saturation because the DC which flows to the oscillator plate, and the DC which flows to the modulator plate, tend to neutralize each other. This somewhat improves the audio quality. The modulator circuit is strictly conventional and is designed for use with a single-button, high-level carbon microphone.

With 300 volts supplied from a dynamotor, the plate current to the oscillator is ad-





# How Telegraphers Are Made

By T. R. McELROY, World's Fastest Telegrapher

## PART II.

**B** LURP! Blurp! Blurpity-blop! Did'ja ever notice the melodious thirst-provoking musicale provided by an oil bottle as it blops out, bit by bit, the oil feed to a kitchen range burner? Y'wanna, sometime. It's great! Now what's that got to do with radio, a fellow might wonder. Well, gents, I'll tell you.

I was sitting in my own radio shack last night, tipping over a few milkshakes (?) with some pals of mine and flipping the dials to hear WSE and WAG and WIM turning out nice stuff. The shack is adjacent to the kitchen. And I was trying to synchronize my own gurgling of Jamieson's Old Scotch (a grade A milk) with the delightful music of the oil bottle.

One of the dames in the shack who probably would make Webster go green with envy at her vocabulary, says to me: "Mac, that blurble is for all the world typical of the musical prelude to one of your gymnastical regurgitational performances." Well, sir, I wiped superfluous suds with the back of my hand and beamed pleasantly upon the little gal and thanked her for the compliment. I thought she was trying to tell me what a great acrobat I might be! We won't discuss that particular episode any further. Suffice to say she explained in my own language what she meant. But here is where it fits into the radio picture.

'Sfunny thing how a fellow will duck a job day after day and week after week, just putting it off through lack of ambition to get started. Here I had a job that I'd promised to do, in trying to tell the gang who read "RADIO" something of my ideas as to making code work easier.

I can't remember exactly where I left off last month, so I can't hope to make this what the telegraph editor might call a "running story". I had a copy of "RADIO", but I left it with a friend of mine, Jimmy, who runs a beer garden. Sometime I'd like to tell you about beer gardens. You see, I wanted to show Jimmy what a big shot I was, writing for magazines and all that, y'know. It'd positively put me on the approved cuff list.

So anyhow, I'll bust right into the subject of technique. Don't look for smooth, errorless writing. I'm no rhetorician. I'm a telegrapher and I don't pretend to be anything else. I'm telling you what experience has taught me, and not what I've studied or read somewhere. And now for the business:

There isn't a great deal that anybody can tell you about receiving. I find that the large majority of men can receive a whole lot faster than they can put the stuff down. Although there isn't an excuse in the world for that. You can pick up a good second-hand typewriter at any pawn shop for five or ten bucks, and many a guy spends that on inconsequential such as rent, light, heat, or food. How much more important to get a mill "the better to enjoy your hobby, my dears", sez Gramma Wolf! It'd oughta take the average operator about two or three weeks to type 40 or 50 words per minute, and that's about as fast as most radio signals fly.

Don't expect to develop any real speed listening to hash. Y'gotta develop speed list-

ening to press. Never mind what any other fellow tries to tell you. Trying to copy hash will develop accuracy; but it's a lot more fun to copy plain press or plain English at 40 wpm and have a few mistakes, than to copy headache provoking junk at 25 or 30 and have it perfect. In a championship contest the fellows really have fun copying the stuff, because you get to following the continuity of the story. So that's that. Speaking of that reminds me of one contest I was in. A man named Joe Chaplin beat me. Swell fellow and a real American. I flopped on oranges and lemons in the contest. And would'ia believe it, to this day I positively gag on whiskey sour because it's main ingrievances (I'd like to tell you about that one sometime) are oranges and lemons. But anyhow, you see what I mean about following the story. You can't get anywhere practicing if practice is drudgery. Y'gotta enjoy it. So flip your dials some night to whatever frequency they use on Press Wireless or some other press station. Most of them work around 40 to 45 wpm. You'd be surprised how much of it you'll get and how much fun it'll be.

One vitally important point on receiving to bear in mind is to keep cool. I've seen fellows working for Consolidated Press in New York drop a whole sentence because of talking while copying, and then continue right on and a minute or two later, still copying, remember what they'd dropped and flop back the typewriter and fill in. You can all do the same. Honest, it's a cinch after you get wise to it. I remember another contest I was in and the word "hospitalization" shot through around 55 or 58 wpm. Now how the Hades is a fellow gonna grasp that at that speed? But a half minute or so later it came to me and I flopped back and filled in. You wanna try it some time just for practice.

I'll come back to that receiving business some other time. I want to tell you something about sending, before I get weary, and quit writing. Now in the name of whatever gods are guardian angels of communications, will you read this carefully? I'm not a fellow who wants to boast. At least not on such abilities as may be alluded to in a nice family magazine. But I make the positive statement with every ounce of energy my big fat fingers can throw into this typewriter, that I can make any man a better sender. I don't care how good you are, or how lousy. Read this and pay attention to it and you'll immediately be better.

D'yuh remember back in the days when you went to school? Most of you are probably my own age, about 35 or 36. And in my school about 25 years ago they were teaching a new fangled writing method consisting of scrawling of queer hieroglyphics on paper by what they called a "free arm movement." Turn back the pages of your memory to those days. And see how the same thing applies to correct sending.

I can't think of anything that'll as correctly describe the two methods of sending . . . correct and incorrect! We were taught, y'remember how tiresome it was to write with fingers, and how it developed "writers' cramp". If you don't remember, ask your old gent, he'll know. And while we're on that subject just recall the prevalence of that ailment years ago as compared with the scarcity of similar complaints today. Now writers cramp—I think specialists like my old pal Candler in Chicago, call it occupa-

tional paralysis. I dunno. But anyhow "glass arm" is the same thing. Not much of it nowadays. Some young fellers might think they've got it. But like other ailments we operators hear about, you don't suspect you have it, or fear you have it. You know you've got it—when you have glass arm. And the especially sad part of it is that it is positively avoidable. The same as writer's cramp.

Take a pencil or pen and try to write with your fingers, old time style, for ten or fifteen minutes. I'll bet a cigar you'll quit with aching fingers. Now write the same stuff with the whole arm movement and if you're anything like me it'll be almost impossible to read it, but your arm and hand will be fresh as a daisy. Now try it with a key. Send ten or fifteen minutes with any ordinary key. Put the peek on your mitt and notice how with a key you've a high hump in your wrist and your fingers are down near the table on the button. Try it. Don't take my word for it. Just geev a look at your wrist. If you could look at an X-ray photograph of those tendons and muscles you'd have a mild case of the horrors to think you'd been abusing your mitt that way.

Now take that key off the table and shove a book under it, to bring the button up where it belongs, about two inches above the table. And then put it in the center of your desk about where you'd have a letter if you were going to sign it. With your elbow just off the edge of the desk. Now flop out dots and see how easy and rhythmically they flow outta your whole arm. Try it! Do it now! Take those code-mutilating keys off your desks and bring them up high where they belong and put them on the desk in front of you where they belong. And see the difference. This thing is a positive phobia with me. I go nuts when I hear lousy sending, because I know that it isn't the op's fault. They just don't sell straight keys that are made right.

Now if you've read that paragraph and if you've done what I've told you to do, you'll find that within two or three nights you can send better stuff than you ever dreamed you could send. I mean it! On the level! Try it, and be a good enough sport to write me and let me know.

And now for the semi-automatics. Oooh! Those double distilled, horrifying code-desecrators. And yet, correctly designed and adjusted, they can be the greatest little plaything in your radio shack. I'm talking about inanimate objects now, don't get off the theme.

The same essentials for straight key sending apply to automatics. The fibre handles must be up where they belong. Take your present automatic if you have one. Slide a book under it. Get those paddles about 2½ to 3 inches above the table where they belong. Take a look at your wrist. You'll see it runs smoothly straight. Now take the book from under the automatic and put your fingers on paddles as you ordinarily do. Look at the hump formed by your wrist. Just try to imagine slapping some bummy rummy across the schnozzle with your wrist cramped. You can't do it!

There is only one correct method of sending, on an automatic. You've got to slap the paddle with your thumb, actuated by your whole arm, to make dots. And you've got to slap it over to the dash side with your whole arm, the index finger and large

(Continued on page 35)





# THE AMATEUR ENGINEER

DESIGN AND OPERATION OF TEST AND MEASURING EQUIPMENT FOR EVERY RADIO PURPOSE

FROM time to time, simple forms of apparatus and tests will be described in this department. The amateur has need of certain pieces of test equipment and should know how to use them properly. One example is a modulated test oscillator which is useful in lining up receivers. When it is calibrated, it is fine for locating short wave bands on an all-wave receiver.

There are numerous forms of modulated oscillators. Those which use an output attenuator, self-contained power supply, and a separate modulator tube are to be preferred. However, for ordinary use around an amateur's station or laboratory, or to align some friend's broadcast receiver, a simple modulated oscillator is satisfactory.

Two types use a single tube for the combined purpose of oscillator and modulator. In Fig. 1 is shown a circuit using either a 199, or preferably a 30 tube. This oscillator uses a blocking grid action to obtain modulation at an audio frequency such as 500 to 1000 cycles. The tone can be adjusted to suit the individual taste by changing either the grid leak or grid condenser. Adjustment of the filament rheostat will also vary the tone and this allows adjustment over the tuning range of the variable condenser. The other type is shown in Fig. 2 and it uses an electron-coupled oscillator with an AC plate and screen supply. Modulation is obtained from the AC plate voltage which gives a 60-cycle tone.

The oscillator shown in Fig. 1 can be built into a metal box with room for a portable 45-volt battery and a couple of No. 6 dry cells. This box can be about 5 inches deep, 10 inches long and 7 inches high, as shown in the sketch of a proposed layout. A two-gang broadcast receiver type condenser will serve nicely by connecting the sections in parallel. The wiring diagram is simple and the only thing to worry about is the correct polarity of the tickler winding to obtain oscillation. The coil can be an old broadcast receiver coil where the primary (tickler in this case) has 20 or 30 turns.

The other AC operated oscillator could be built into a metal can about 8 inches long, 6 inches high, and 4 or 5 inches deep. An old bell-ringing transformer or a filament transformer is used to heat the filament of the electron-coupled oscillator. The condenser is the same as previously described. A 10 millihenry RF choke and an output attenuator can be used in this circuit to obtain variable output. The cathode winding must have an optimum value of turns to obtain the correct amount of modulation from the AC plate supply. It would probably be desirable to wind a special coil with taps every five turns from the lower end in order to find the best tap in the actual oscillator set. This coil should be about 120 turns of No. 30 DSC wire on 1/4-inch tubing. Small mica condensers isolate the can and output circuit from the 110-volt AC circuit. The only disadvantage is in the very low frequency of the modulation.

Calibration of either of these oscillators can be accomplished by means of a broadcast receiver. The high frequency range of the oscillator down to 550 KC can be calibrated by means of picking it up in a calibrated receiver or by beat note reception of known frequency broadcast stations and the oscilla-

tor signal. The upper range can be calibrated roughly by extending the curve, or more accurately by using the second harmonic which will be audible in the broadcast range in the receiver. Dividing this reading in each case will give the fundamental fre-

stations, either amateur or broadcast. For example, if the short wave station is listed at 6.01 megacycles, the oscillator can be set at 1502 1/2, 1202, 1001 1/2, 857 KC, etc., which will all give harmonics on 6.01 MC. By the next preceding stage can be lined up checking at least two fundamental points, one can be sure of which harmonic is heard in the short wave receiver. The fundamental of 1502 1/2 has a harmonic on 4 1/2 MC which might cause a mistake to be made, but swinging the oscillator over to 1202, the next fundamental having a 6.01 MC harmonic would give no harmonic at 4 1/2 MC.

The frequency of a quartz crystal to be used in a single signal receiver can be found fairly closely by setting the quartz plate on, or leaning it against the grid of the oscillator. At resonance the oscillator will suddenly change, as listened to in a broadcast receiver tuned to the oscillator second harmonic. This test means manipulation of both the oscillator and BCL receiver, but once the crystal frequency is found, the IF amplifier in the single signal receiver can be lined up to that frequency by means of the oscillator.

Lining up an IF amplifier should always begin at the grid of the tube preceding the last stage of IF transformer. After that transformer is aligned (by ear or output meter), the next preceding stage can be lined up using less coupling to the grid of the next preceding stage. Always work with a fairly weak signal, because many sets have AVC which would cause trouble with a strong signal peaking, unless a meter is used.

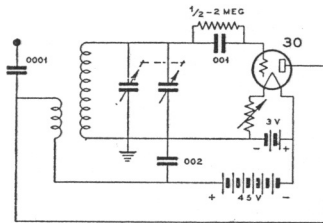
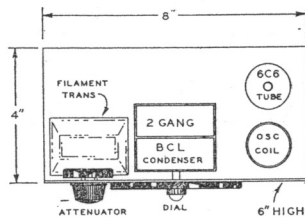

FIG. 1

Circuit diagram of Modulated Oscillator with type 30 tube for battery operation.



Parts layout for battery model.

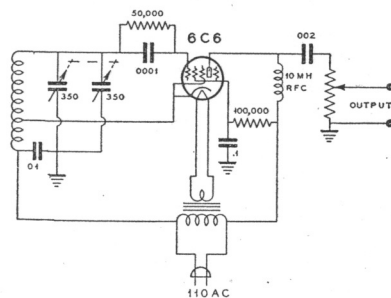
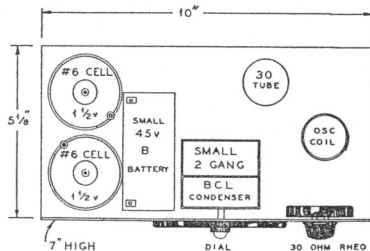

FIG. 2

Circuit diagram of A.C. oscillator.



Parts layout for A.C. oscillator.

quency of the oscillator. The latter should tune up to about 350 KC, which makes it useful to line up 450 KC superheterodyne receivers.

If a careful calibration of the fundamental frequency is made on the oscillator, the harmonics may be used to locate short wave

## HAM HINTS

There are two reasons why a blue glow can be observed in a transmitting tube, mercury-vapor tubes excepted. (1) Ionization—This is the blue color which is usually observed close to the plate, grid and filament structure. It indicates a gassy tube and sounds the death knell of a tube in which a thoriated filament is used. A tube that turns gassy has been either improperly designed or pumped, or both. (2) Fluorescent Glow—This glow is present only on the walls of the glass envelope and is never seen close to the tube elements. It is caused by what may be termed "radio-active" phenomena. Certain elements in the glass fluoresce when bombarded by high velocity electrons. Because the plate does not completely shield the filament and grid from the glass envelope, some of the electrons accelerated by the grid shoot out either above or below the plate and strike the glass. It is at these points of impact that this type of blue glow is seen. The glow is usually visible for only a few seconds because the impact of the electrons quickly builds up a negative charge on the inside wall of the glass envelope and prevents any additional electrons from actually touching the glass. The negative charge on the glass repulses the electrons, which are negative particles of electricity (unlike charges attract, like charges repulse each other.) Fluorescence on the glass is usually found only in tubes with a high mutual conductance and which are being operated with fairly heavy grid excitation.

## Addressed To Members of Congress (Continued from page 10)

Electric and certain of its engineering notables, about the excellent design of this little W.L.L., about its wonderful performance; but the name of Billy Jackson was never mentioned—not even in the fulsome description published in the amateurs' own magazine.

Before 1927 waves of 200 meters and below, (which is the same as saying 1500 KC and above), belonged to the amateurs. There was no law in the land that could have deprived them of this territory. They could have held the whole of it or any part of it entirely for their own use if they had needed it all or if they had even desired it all. There was no means by which they could have been lawfully dispossessed. But they had long since been induced by the commercial interests and their adherents in the government employ to confine their operations to certain narrow bands in the regions of 160, 80, 40 and 20 meters. Although the width of these bands had been fixed without regard for the rapid increase in the number of amateur stations that were being licensed day after day, nevertheless they were cut still further, (in fact, to about one-third of their width), at the international radiotelegraph convention of Washington in 1927. And, on top of this extreme restriction, foreign nations immediately ignored the amateur provisions of the convention and operated high power transmitters within the amateur bands. Japan alone officially filed with the Berne Bureau on 9 channels in the amateur bands, operated high-power stations on them and disrupted the communications of amateur stations in the Philippines, Hawaii and our west coast states. It was a year before she could be induced to stop this violation of the treaty.

This inexcusable commercial interference was serious to many people, for the amateurs maintain a free message service across the Pacific ocean. Many thousands of our own citizens reside or sojourn in the Orient, in the Philippines, Guam and Hawaii—Army, Navy, Marine Corps, missionaries, doctors, nurses, school teachers and other civilians. These people all have need for quick communication with their families and acquaintances in the United States. As a rule they have not the money to pay the high tolls exacted by the commercial radio and cable corporations. So the amateurs have been keeping up for years a free message service for all of these people, handling as many as 3,000 radiograms a month across the Pacific. The amateurs were doing this long before the commercial radio people had any trans-Pacific circuits. It is a great public service, performed absolutely without charge, and its disruption by treaty-breaking commercials was outrageous. Subsequent to this third restriction of amateur space that was contrived at the Washington Convention there was a case in the Court of Appeals of the District of Columbia designated by the numbers 4987 to 4991, being actions brought by the Radio Corporation and others against the Federal Radio Commission. The following quotation is from the printed record in this action:

*"Prior to February 23, 1927, they\* were entitled to use the entire range of frequencies from 1,500 kilocycles upwards. They were the first to make practical use of short waves and demonstrated their efficacy to the world by feats of the most dramatic character. Their contributions to the science of radio communication have only too often been the demonstration of the utility of frequency ranges only to arouse the desires of commercial interests to deprive them of the use thereof.*

\*The Amateurs.

*"At the various National Radio Conferences, speaking through their authorized representatives, they offered to relinquish most of their territory for commercial development.*

*"In recognition of their utility and in realization that from the amateur ranks came the radio operators who gave our Army and Navy their communications during the late war as well as most of the radio inventors, engineers, technicians, and operators, it is to be regretted that the provisions of the International Radiotelegraph Convention have afforded them so little in the way of frequency bands."*

This appears in a document entitled "Statement of Facts", presented to the court by the Federal Radio Commission.

Regardless of the concern for the rights of amateurs which may be implied in the foregoing quotation the actions of government employees inevitably favor the commercials.

At the time of this court action the present amateur bands were severely congested with only 17,000 amateurs in the United States. At this writing, January 1, 1935, there have been licensed over 46,000 who must all use the same bands!

It may be necessary to explain to the layman the sentences, "Prior to Feb. 23, 1927, they were entitled to use the entire range of frequencies from 150 KC upwards. . . . At the various national radio conferences, speaking through their authorized representatives, they offered to relinquish most of their territory for commercial development." Before that date there was no radio law that could have been invoked to take the short waves away from the amateurs. In 1914 some of the amateurs organized themselves in the form of the American Radio Relay League for the advancement of amateur interests and the protection of amateur rights. The organization grew in numbers and influence and assumed the job of spokesman for all the amateurs of the United States. It started a magazine in which were published the discoveries and developments of the amateurs. They had never concerned themselves with protecting their discoveries; amateurs and commercial people alike were at liberty to make use of them. Until 1920 the ARRL remained wholly an organization of amateurs. But in that year, (disasterously for the amateurs it turned out to be), the men in control of the organization threw it wide-open to all who chose to apply for membership or who had subscribed to the magazine. The result was that immediately the organization was filled with commercial people and other non-amateurs whose interests lay in securing the amateur waves for themselves. Soon the ARRL and all its considerable assets, including the official magazine, came under the majority ownership of commercial interests. Its "authorized representatives" thereafter were of necessity in the employ of the commercials. The ARRL having established itself as "spokesman for amateur radio" has continued in that role, although it embraces only a portion of the amateurs of the United States and its membership is preponderantly commercial and non-amateur. So the significance of the statement quoted from the court records, "speaking through their authorized representatives they offered to relinquish most of their territory for commercial development," is significant.

And this is why it is that the amateurs of America are constrained to take their case direct to their senators and their representatives in the Congress of the United States.

Every senator and representative has many of these radio amateurs among his constituents. It is not alone the 46,000 amateurs whose desires and interests are at stake; they all have families and friends and a host of ardent supporters. The amateurs are the advance guard of Citizen Radio—of a movement that will surely result in the citizens of the United States having some adequate use and control over their own domain of the air.

Much of the short-wave territory that was taken from the amateurs is unused today. Part of it is merely being "held" by commercial corporations which had applied for and secured many more channels than they had or ever will have use for. Much of the territory is being reserved by the Federal Communications Commission for future commercial or government needs. But government employees have never expressed any concern for the future needs of new amateurs that they are licensing at the rate of many thousands a year. A surer method of killing off citizen radio preserving the air wholly for the commercials could hardly have been devised. Just continue to crowd many thousands more of stations each year into the same channels and let the amateurs choke one another to death! However much we may stand amazed at the cold-bloodedness of the plan we must admit its ultimate effectiveness.

The amateurs require that a sufficiency of this territory for their present and future needs be restored to them. Channels that are being monopolized by stations that are not serving the public interest can be vacated. Where stations actually serving a public need must be moved to make room for the amateurs the "moving" constitutes no removal of physical property; the process consists of turning a few dials to adapt the transmitters to other channels.

It is the common belief among commercial radio men that at the next international radio convention a determined effort will be made to drive the amateurs wholly from the air. By means of the machinery of these international conventions—always dominated by commercial people—it is comparatively easy for the commercial interests to accomplish this unless the United States delegates are specifically instructed by Congress. The foreign commercials who dominate the foreign delegations are virtually all against amateur radio. The United States commercials have no use for the amateurs, either, except as a market for radio parts and apparatus and as a reservoir of available men at which they may point in meeting the wage demands of their employees.

So there is slight disposition on the part of an United States delegation to stand out against the insistence of the many foreign representatives. Therefore it is necessary that Congress order the United States delegation to take a flat stand for the rights of the United States amateurs and all other citizens of the United States who are non-commercial users of the air. It is common knowledge that at these international radio conventions what the United States determines it will do the conventions will adopt. It is high time that squabbling and intriguing foreign nations and commercial corporations cease to dominate the radio affairs of the citizens of the United States.

Prior to the next international convention—which is scheduled to take place at Cairo in 1937—senators and representatives in Congress will be fully informed of the needs of the United States amateurs.

Clair Foster,  
Amateur Station W6HM.

# "Junkbox Special" Beginners' Phone

By "LINEAR"

THERE has been a consistent demand for information on a small capacity-coupled phone transmitter and thus we present our first rig of this type, because we spent as much time getting the bugs out of this one as it would have taken to build three link-coupled transmitters.

The circuit starts with a conventional '47 oscillator and a '45 is used in the final amplifier. The '45 tube was chosen because it has a very high grid impedance, whereas the '46, on the other hand, has a very low grid impedance. This simply means that the '45 likes to be driven by a lot of RF volts, but draws very little grid current, which is just what the '47 likes to supply. On the other hand, if a '46 tube is used in the amplifier stage it would require comparatively few grid excitation volts, but draws a lot of grid current. Therefore some form of stepdown is required between the oscillator plate tank and the grid of the '46, if a transfer of any appreciable amount of excitation is expected, and thus get good output. For this reason the '46 is entirely unsuited for capacity-coupled circuits, while the '45 (or the 2A3) represents a fair compromise.

No mention has been made of tapping down on the oscillator plate coil because this practice seems to be "out", due to the tendency of the oscillator to oscillate when this is done. The coupling between the oscillator plate coil must, for best results, be adjustable and this is accomplished by condenser C3, which is a midget variable of about 25 mmf. maximum capacity. It has been found that any value larger than 25 mmf. is unnecessary because the oscillator stops oscillating when a greater capacity is used. As a matter of fact, C3 is operated with the plates almost all the way out. The RF choke in the grid circuit of the '45 is very important for 160 meter operation and is best made up of a combination of a new type small Hammarlund or National RF choke in series with an ordinary broadcast band RF choke, which can be secured from any radio dealer.

The plate circuit of the '45 is entirely conventional. It uses a split-stator tank condenser of the midget variety in order to minimize neutralizing difficulties and to avoid the use of a large by-pass to ground at the coil center-tap, which would bypass the high audio frequencies supplied by the modulators.

THE Collins antenna coupler is practically essential for 160 meter operation because almost all 160 meter amateur antennas are shorter than 1/2 wave (260 feet) long, and therefore must be worked against ground (Marconi type). The ideal way to feed a Marconi type antenna is by means of the Collins pi network, because all forms of inductively-coupled Marconi antennas are quite critical in ad-

The 250s in parallel are driven by a single '57, pentode connected, by means of resistance coupling. This provides sufficient gain to work out of a double button carbon microphone connected to the primary of T1, which is a double button mike-to-grid transformer.

The volume is controlled by means of the grid potentiometer R5, which is 1/4 meg. variable resistor, and is so connected that hand capacity is avoided.

The power supplies are conventional and there is no need to worry about voltage regulation because all of the plate currents in the transmitter remain constant during modulation.

using a 50 or 100 MA meter. The stage is neutralized by varying C4 until the meter at J2 no longer shows a dip when C5 is tuned through resonance. When this point has been found, the stage is neutralized. Now move the milliammeter from J2 to J3, after removing the plug from J3. This applies plate voltage to the '45 stage. C5 should then be tuned to resonance, which will be indicated by a minimum current at J3. This accomplished, cut off the plate voltage and replace the antenna coupling condenser C1 on the end of the plate tank L2. Then turn on the power supply once more. C6 nearest the antenna should be placed at about half capacity, and C6 nearest the plate

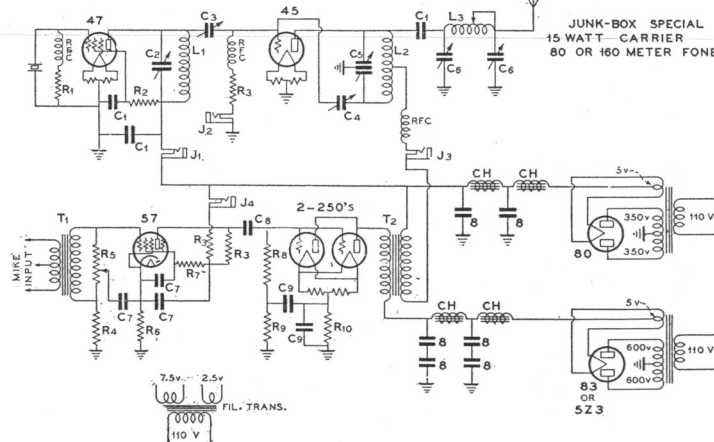

## Constants For Junkbox Special Phone

- C1—006 mica. C2—100 mmf. midget variable.  
 C3—25 mmf. midget variable (use 100 mmf. and remove alternate plates). C4—25 mmf. midget variable. C5—40 mmf. split-stator variable. C6—350 mmf. BCL variable. C7—1 mfd. C8—.01 mfd. C9—1 mfd.
- R1—30,000 ohms, 2 watt. R2—30,000 ohms, 2 watt. R3—50,000 ohms, 5 watt. R4, R5—1/4 meg. R6—500 ohms, 5 watt. R7—1/2 meg. R8—500,000 ohms. R9—25,000 ohms. R10—400 ohms, 10 watt.
- T1, T2—See Text.  
 L1, L2, L3—See coil table in September issue.  
 CH—All four filter chokes are 100 MA, 30 henry.

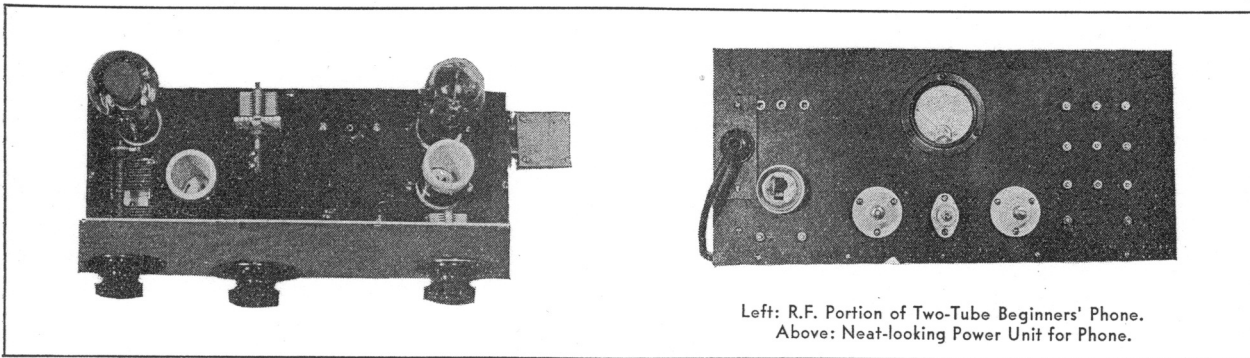

Left: R.F. Portion of Two-Tube Beginners' Phone.  
 Above: Neat-looking Power Unit for Phone.

justment. It may be well to state that Marconi antennas require an exceptionally good ground system if a high radiation efficiency is to be obtained. Any old water pipe will not do. A lawn sprinkler system is best, the next best consists of a counterpoise which is made as long as is convenient, and which has a very high capacity to ground.

The final amplifier draws 50 mills at 400 volts and thus the DC plate input equals 20 watts; therefore 10 watts of audio power (more or less undistorted) is necessary for complete modulation. This power is easily supplied by the two 250s in parallel, operating at 600 volts. The output transformer T2 is a 2:1 step-up transformer and should be fairly heavy in order to avoid DC saturation.

It is quite important that the windings of T2 are properly polarized, in that the DC from the 400 volt power supply and the DC from the 600 volt power supply are connected at the opposite ends of each winding so that the flow of DC through one winding will tend to neutralize the other, instead of adding together. This minimizes core saturation and brings up the low frequency audio response, thus adding naturalness to the quality of the speech.

THE tuning procedure is as follows: Light all filaments and place a dead plug or a small piece of wood in jack J3, in order to remove plate voltage from the '45 amplifier stage. Then turn on the low voltage power supply, thus applying plate voltage to the '47 crystal oscillator and the '57 speech amplifier. A 0-50 MA or larger milliammeter should be plugged into J1, and condenser C2 should be rotated until the current read at J1 is at a minimum. Then shift the meter from J1 to J2. Slowly increase C3 from minimum capacity until the crystal stops oscillating, which is indicated by an absence of current at J2. Immediately reduce the capacity of C3 slightly, and retune C2 until the crystal starts again, at which point grid current will again be indicated on the meter which is plugged into J2. Maximum current is required at J2 without stopping the crystal from oscillating. Now proceed to neutralize the '45 amplifier stage. Remove the tap which connects the antenna coupling condenser C1 to the plate tank L2 and rotate C5. Because the stage is not neutralized, resonance will be indicated by a dip in the current shown at J2. This dip will be very small, only a millamp or two, so you will have to look closely to see the dip, if you are

tank should be rotated until minimum current is indicated at J3. This current will probably be either greater or less than the 50 milliamperes at which the stage is to be operated. If the current is higher than 50 milliamperes, there is too much capacity in the C6 closest to the antenna, and if it is less than 50 milliamperes, it is an indication of too little capacity; thus the condenser must be varied accordingly. It is found that by varying this condenser the entire antenna circuit is detuned. Resonance, as indicated by the dip in plate current at J3, must be restored by a slight retuning of the C6 closest to the plate tank. It must be observed that at no time after connecting the antenna coupling condenser C1 to the plate tank L2 should C5 be adjusted. If it becomes necessary to readjust C5, or to re-neutralize, the antenna coupling system must be entirely disconnected from the plate tank L2.

Now turn on the modulators and talk. The milliammeter should be placed in all of the jacks, successively, while talking, to make sure that there is no variation in plate and grid current anywhere in the transmitter, which indicates improper operation and consequent distortion as well as overmodulation in some cases.

## Mercury-Arc Rectifiers

(Continued from page 16)

on the coil. A few turns more or less do not matter; this transformer is not critical as to voltage. Overwrap the winding with empire tape or cotton tape for protection. The winding can be doped with insulating varnish or beeswax and rosin, but do not use shellac.

Take the other long leg (or for improved regulation wind over primary) and wrap on more empire cloth, since this is the hot side, 0.010 empire will stand 8000 volts (800 volts per mil) but do not trust one layer. Wrap on 5 or six layers and tie it so it will not unwrap. Now lay short lengths—about 7 or 8 inches—of empire tape lengthwise on the core. Use about twelve pieces so that they overlap one another. Tie the ends to the core to keep them in place and start the winding.

The following method of winding the secondary is unusual but has its advantages. Start at the center and wind two separate secondaries. This makes the center tap the inside ends and brings the end leads on the outside of each coil. Be sure the winding is all in the same direction. Wind 225 turns on each coil, layer wound, leaving  $\frac{3}{8}$  inch space at each end for core clearance. After finishing the windings, fold the pieces of empire tape back over the coils and tie down roughly. Assemble the ends in the core and test the voltage across the secondary with open circuit and with a 4-ampere load on ONE side. This will give an idea of the regulation of the transformer. The regulation will vary somewhat, depending on the care in cutting the ends of the core strips and the amount of insulation under the windings. The loaded side should measure 50 volts. If it measures more, a larger value of resistance can be used in the keep-alive circuit, or a tap can be brought out of the secondary to give the proper value. This is the reason why the secondary is wound so that the ends of the windings are on the outside.

The choke can be built on a core 1 inch by 1 inch, U-shaped, about 3 or 4 inches long. The core is not critical as to size. Wind 300 turns of No. 16 S.C.E. wire, either layer or scramble wound.

The end of the core is left open for reasons shown later.

First class chokes can be obtained very cheaply from discarded A eliminators. Those having double chokes are exceptionally suitable. Two chokes from two "A-Box" eliminators, purchased for fifty cents each at a radio junk shop, can be used.

The whole choke can be insulated from ground and insulation of the winding is therefore unnecessary.

The transformer can be mounted in any convenient location, but the choke must be mounted so that one leg is under the automatic starter which is operated by the flux in the core. The most satisfactory method of mounting is shown in the photograph. The Mutli-Arc is mounted on a bakelite panel with the choke fastened underneath.

The isolation relay should be screwed down on top of the panel over the other leg of the choke as shown in the illustration. An armature taken from an automobile generator cut-out, or a plain strip of spring steel with a contact point at one end can be used for the relay. Vibrator points taken from Model T Ford coils are satisfactory; the entire assembly can be removed from the top of the coil and mounted on the panel.

Usually there is enough leakage flux from

the choke to operate the relay through the bakelite panel, but if any lack of flux is noted, a short steel stub should be pressed into the bakelite.

Mount the Multi-Arc so that the well under the starter has a drop of mercury in it and connect up the transformer and chokes as shown. Turn on the 110 volts.

The starter in the Multi-Arc should vibrate, producing a spark at the surface of the Mercury Cathode sufficient to start the arc. As soon as the arc starts, the relay should be examined to see if the contacts are separated. If not, it should be adjusted so that the contacts will remain separated with the arc operating, and the contacts should close as soon as the arc stops. The current in the center tap of the transformer should be 3 or 4 amps. DC. If it is more, a resistance such as a heater coil element or three 21-candlepower auto headlights in series should be inserted in the center tap or the transformer primary. If the starter vibrates but the arc does not start at once, or starts only after the tube is warmed up, the transformer voltage is too low and more turns will have to be put on the secondary. When the operation and adjustment of the Multi-Arc becomes familiar, the keep-alive current can be further reduced to as low as 1 amp, thus further economizing the rectifier system.

## Lafayette Transmitter

(Continued from page 14)

buffer is amplifying by opening SW2, observing the signal from the oscillator alone, and then closing SW2 and noting the difference.

You now have RF feeding the 46s through the coupling condenser C9. With a neon tube touched to the stator of C3, adjust C5 until all RF disappears from L3-C3. Plug the 0-200 MA. meter into J4, press the key and adjust C3 for minimum plate current.

The tank coil L3 is provided with a link coil, for coupling to an antenna or to feeder lines.

The 2B6 can, of course, be used for frequency doubling. In this case you do not have to worry about neutralizing the buffer section. For instance, with an 80-meter crystal, L1-C1 is tuned to the crystal frequency, but L2-C2 and L3-C3 are tuned to the second harmonic, in these 40-meter band. Other combinations may readily be tried. Different amateurs have different ideas in this regard, and the flexibility of the circuit permits all kinds of experimenting.

In the diagram there are two posts marked "MOD". For CW these are shorted, but for phone they are connected to the secondary of the modulating transformer of a companion unit.

The complete Lafayette transmitter using the circuit of Fig. 1 is shown in the photographs. The construction is strong and rigid, and the placement of the parts closely follows their circuit positions. The front panel measures 19 by 8 $\frac{3}{4}$  inches, the chassis 17 by 11 by 2 $\frac{1}{2}$  inches. The black enameled case is 19 by 12 by 9 inches.

The power pack occupies the rear of the chassis. In a straight line across the center, reading from right to left, are the crystal, the neutralizing condensers, the bias control, one 46 and the amplifier tank coil. Just behind the panel are the oscillator and buffer coils, the 2B6 and the other 46. The wiring is directly point-to-point, the RF leads being less than four inches long at the most.

The front panel is neatly balanced. Oscillator, buffer and amplifier condensers are

represented by large knobs and dial plates. At the right is a 0-25 ma. meter for oscillator plate and amplifier grid current readings; at the left a 0-200 ma. meter for the buffer and amplifier plates. The meters are connected to plugs that fit either J1 or J3 and J2 or J4, respectively. The three snap switches are on the same line with the jacks.

This transmitter is much simpler than many receivers, and although its description sounds involved, it can be tuned up completely and put on the air in about ten minutes. It produces clean, steady signals of which any amateur will be proud. Laboratory measurements of the output, using a 100-ohm non-inductive dummy antenna, show an output of slightly more than 45 watts with 60 watts input to the 46s, on all bands except 20 meters. On 20 meters the output drops to approximately 37 watts with the same input.

## Putting the 802 to Work

(Continued from page 20)

other  $\frac{1}{4}$  meg resistor, which keeps the audio frequency modulating voltage from shunting back to ground at that point.

If a high-quality microphone and pre-amplifier is used ahead of the 6C6, this transmitter is capable of exceptionally high fidelity results, although the small power output hardly justifies the expenditure.

Suppressor-grid modulation is "efficiency modulation". The plate input to the 802 should remain constant, whether or not the transmitter is being modulated. Thus the suppressor can only vary the power output by varying the efficiency of conversion of DC plate input into RF power output.

The unmodulated plate efficiency is approximately 25 per cent, and under complete modulation the instantaneous plate efficiency is swung from the unmodulated value of 25 per cent up to twice that value, or 50 per cent, then down to zero, and then back to the 25 per cent point, during each audio frequency cycle.

Suppressor-grid modulation has the advantage that it is relatively simple to adjust and requires but little audio power to effect deep modulation. Its principal disadvantage is the low unmodulated plate efficiency, which requires large tube capacity for a given amount of carrier output.

## ERRATA NOTICE!

● The circuit diagram for the Frank C. Jones "222" Receiver, shown on page 15 of January "RADIO", is incomplete. A connecting wire must be run from the screen of the 57 oscillator tube to the screen of the 58 I.F. Amplifier tube. The circuit as shown does not provide for screen current to the oscillator tube.

### Stockton Hamfest Plans Completed

● Amateurs of Stockton, California, will stage a mammoth hamfest on March 2nd. The Hotel Stockton has been chosen as the meeting place. The hamfest committee reports the dinner will be in keeping with the traditions of the artistic and hungry American amateur, the forgotten man. There will be entertainment second only to that provided by the Ziegfeld Follies. A record attendance is expected. The tickets cost only \$1.00 and reservations can be made through any Stockton Amateur. J. N. A. Hawkins and Frank C. Jones of "RADIO" will address the gathering.

# A Simple and Efficient Amplifier For Velocity or Ribbon Microphones \*

• The Velocity or Ribbon Microphone opens a large field for the amateur and service men. The difference in quality between the new microphones and the old is immediately noticeable. There is no doubt but that the older diaphragm type microphones will be replaced by the newer types.

The Velocity Microphone is unusually rugged and requires no service. The absence of background noise and the elimination of acoustic feedback are also greatly in its favor. Temperature, humidity, or attitude do not affect it in the least.

Until recently, only large stations could afford this newer type of microphone. Today, however, Velocity Microphones with excellent frequency response can be obtained at very reasonable prices and are within the reach of all.

The development of the Velocity Microphone has created a need for an amplifier that will bring its small output up to the level required by the standard amplifier. Then again, a Velocity Microphone has an excellent high and low frequency response due to its open structure and its perforated case. Such a construction does not limit the frequency response as is the case when a ribbon is enclosed. An amplifier which will permit the full benefit of the excellent response of such a microphone must have a useful range between 30 and 12,000 cycles. Such a pre-amplifier, although simple in its operation, presents certain difficulties—particularly those which are AC operated.

Its simple construction, ease of operation, and low cost, puts this pre-amplifier within the reach of everyone. Most important, it eliminates the AC pre-amplifier's worst enemy—hum. The hum adjuster used is not exactly a hum eliminator but a hum buckler. Yet, unlike most hum bucklers, it not only eliminates background noises but does not introduce any AC ripple during the periods of modulation.

It is a well-known fact that the worst offender is the source of grid bias. A certain part of the AC heater supply, therefore, is introduced on the grid circuit in opposite phase to the existing hum. By merely adjusting the hum buckler, the correct amount of "bucking current" can be introduced.

Automobile tubes have been selected for this pre-amplifier for two reasons. (1) They offer a minimum level of thermalagitation noises. (2) The lower heater current creates a much weaker field around the cathode than those tubes of the 2½-volt series.

It is needless to say that although the pre-amplifier circuit is a simple one, high grade parts should be used in its construction. The final result cannot be any better than the poorest component. All transformers should be designed for the feeble currents encountered. They should pass the entire audible range. Condensers or resistors should operate quietly. Wire-wound resistors are advisable for the plate coupling resistors, although there are some high-grade carbon resistors that function equally well. The power supply is built as a separate unit in order to prevent hum pick-up between the input transformer (line-to-grid) of the pre-amplifier and the main supply transformer.

\*Engineering Division, The Amperite Corporation.

The two transformers should be at least four feet apart. By varying the relative position of one transformer to the other, it is also possible to obtain a minimum pick-up at a smaller distance. The position of the output transformer is not critical.

In some cases, the "B" supply for the pre-amplifier can be obtained from the main amplifier. If the main power supply is taxed so that modulation causes variations in the "B" voltages, such variation on the pre-amplifier will cause motor-boating. The power "B" supply should only be used for the pre-amplifier when the voltage variations between the conditions for no load to maximum output do not change the "B" voltage by more than 5%. This can readily be checked with a voltmeter.

The gain of the pre-amplifier here described is 54 dbs. when an input transformer of 150,000 ohms secondary impedance is used to drop the response curve on the higher frequencies. However, if the microphone is to be used on speech only, a complete cut-off at 5,000 cycles would not impair the quality of reproduction. In this case, an impedance

as high as 250,000 ohms can be used to provide higher gain.

One characteristic of the power supply which must not be overlooked is the use of buffer condensers. Although buffer condensers seem to have gone out of mode with the passing of the gaseous rectifier, their purpose in this case is not exactly the prevention of RF currents but to cut down the peak value of the transformer voltage. You will find that their use will bring down the value of the ripple without further changes in the filter circuit. Another "outmoded" feature is the introduction of a DC potential between the heater and cathode of the amplifier tubes. It is no longer helpful on the average radio receiver or medium-gain amplifier, yet it will give a marked improvement when an overall gain of 120 to 150 dbs. must be realized from the entire amplifier.

The combination of the ribbon microphone and amplifier here described will give a flat response over the entire audible range. It is an ideal unit for public address or speech input equipment for low or medium power transmitters.

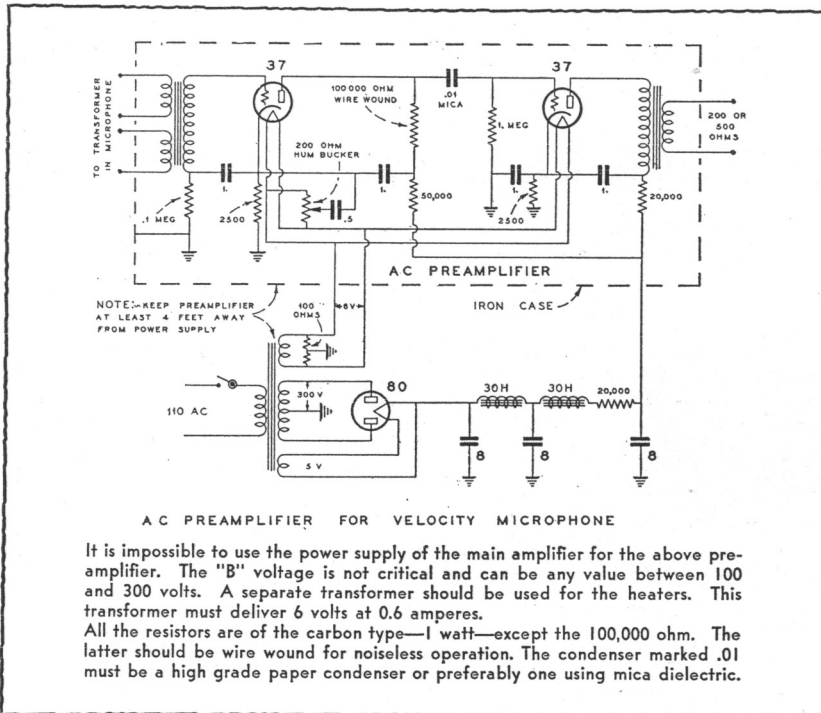

It is impossible to use the power supply of the main amplifier for the above pre-amplifier. The "B" voltage is not critical and can be any value between 100 and 300 volts. A separate transformer should be used for the heaters. This transformer must deliver 6 volts at 0.6 amperes. All the resistors are of the carbon type—1 watt—except the 100,000 ohm. The latter should be wire wound for noiseless operation. The condenser marked .01 must be a high grade paper condenser or preferably one using mica dielectric.

## Filament Transformer Problems

• The average filament transformer for heating the filament of a transmitting tube is usually made to extraordinarily poor tolerances. Few transformer manufacturers seem to appreciate the necessity for maintaining the filament of a transmitting tube at exactly its rated value. Most of the filament transformers seem to have been designed by an engineer whose line voltage was approximately 135 volts, because on the conventional 115-volt power lines it is usually just barely possible to get the rated 10 volts measured at the transformer terminals, even without load.

Every filament transformer should have the primary tapped for operation on 105, 115 and 125 volts. If the transformer manufacturers and amateurs at large would realize that 25 cents saved on the filament transformer can easily shorten the life of a \$25 tube by as much as 50 per cent, it is plainly evident that it is poor economy to use cheap design and materials in building a filament transformer.

There is no substitute for a filament voltmeter PERMANENTLY connected across the socket terminals of the tubes used in the final amplifier.

"R/9" is glad to announce  
that Mr. ROBERT S. KRUSE  
has been appointed as

**TECHNICAL EDITOR** effective with  
the October issue

Mr. Kruse will be remembered as the Technical Editor of "QST" for many years. He is now an internationally known consulting engineer and technical writer on high frequency radio.

Coming in "R/9"



Articles on these and many  
other subjects.

Better than Break-in  
Tank Circuit Economy  
The "No Loss" Antenna  
Class B Audio in Plain Terms  
High Power from Small Tubes  
Predicting DX by the Calendar  
A 7-tube, \$6 Superheterodyne  
A Simple Modulation Indicator  
Diamond Antennae for Amateurs  
Anti-Noise Receiving Antennae  
Several articles on Grid Modulation  
More on Single Sideband Transmission  
Direct Comparison of Antenna Feeders  
Doubling in Final Amplifier at 80% Efficiency  
"Worked 21 Zones"—a fairer DX measure  
Primary Keying and Non-Sticking Relays

The Unprofitable Class B R.F. Amplifier  
Several articles on Superheterodynes  
Methods of Single Signal Reception  
500 Watts from a Crystal Oscillator  
Saving Transmitter C Batteries  
An Oscilloscope for \$2.85  
A "Tri-tet" R. F. Amplifier  
The Crystal's Rival—high-power oscillators with near-crystal stability  
A 1000-watt transmitter with crystal oscillator and one r. f. amplifier  
Cheap, automatic temperature compensation for crystal oscillators  
Unity Coupling—more efficient r. f. inter-stage coupling without grid chokes  
ABACS—a series of "em"—solve your numerical radio problems with a ruler!

Articles from R. S. Kruse and C. D. Perrine, Jr., W6CUH, in every issue. Regular contributions from other world famous engineers and amateurs. Our unique "amateur affairs" content which made "R/9" famous over night, is a feature of every issue.

No Extravagant Claims . . . Just a Good Magazine at  
a Moderate Price

\$1.50 the year

Two years, \$2.50—8 months trial offer, \$1.00

To U. S. A., Spain and all independent American countries. Extra per year to other countries; Newfoundland, 25c; Canada, 75c including current duty; elsewhere, 75c duties, if any, not included

R/9, LIMITED, 1455 GLENVILLE DRIVE, LOS ANGELES

## Add THOUSANDS of Miles To Your Range!



Fourteen stations heard in a single sweep across the 49 meter broadcast band, 8 of them announcing in foreign language. Six stations on the 31 meter band where there had been two before. Amateur C.W. from four continents in one night on 40 meters in a location where even VK's had not been heard before. More signal and less noise on all stations, R2 signals boosted to R9—and more important, "RO" signals raised to R6.

The Sargent Regenerative Pre-Selector does just this when it is added to any good short wave set—preferably a super-het. It helps BROADCAST TYPE supers just as much as it does amateur type. Operates from 15 to 550 meters, helping greatly on broadcast band DX also. It is the greatest development in ten years for the DX fan. Order Net \$14.75 yours today. IMMEDIATE DELIVERY.

### It's a Treat to LISTEN IN on This One!

Everything you want in a real Short Wave Receiver. Hundreds sold to enthusiastic amateurs and fans is our best testimonial. Tunes 15-550 meters, band spread, beat oscillator, self contained power supply. Price includes tubes and dynamic speaker unit. Nothing else to buy. 5-Day Money Back Trial. Order Yours Today. Net Price \$54.50

MARINE MODEL 8-34  
As above, with another waveband added. Continuous tuning, 15 to 1500 meters. An ideal shipboard receiver. D.C. prices on request. Net Price \$62.50

AN UNBEATABLE COMBINATION  
The DX Hound's dream come true, at a price he can afford to pay. Buy the Sargent Pre-Selector and 8-34 Receiver,—there is nothing better at any price. Total cost, ready to operate, only Net Price \$69.25

Write for Our Catalog

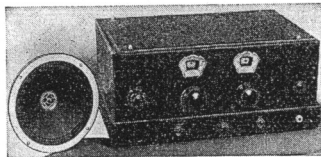

Sargent 8-34 Receiver

IMMEDIATE DELIVERY

**E. M. SARGENT CO.**

212-R Ninth St. Oakland, Calif.

## Limitations of Plate Supply Transformers

(Continued from page 11)

that the temperature rise of the power transformer is directly proportional to the wattage dissipated, we find that in this (D) consideration, the transformer temperature rise in Joe's transformer was more than 5 times normal. If the transformer was originally designed for 50 degree rise, this would mean that the final temperature under this last method of operation would be about 250 degrees C. This temperature would quickly carbonize the paper insulation and ruin the other insulation of the transformer, causing breakdown.

Looking at the previous discussion in another light, we can use the chart of Fig. 1 to determine the reduction in DC current available from a standard plate transformer in any of the less usual rectifier circuits. The average amateur plate transformer is designed and rated on the basis of a full wave rectifier using choke input. If this transformer is to be used in a circuit with a condenser input filter, the DC current should be reduced to .7 times the normal DC rating for correct temperature rise. If the transformer is used in a bridge rectifier having choke input, the DC load current should be reduced to .5 times the normal DC rating. If the bridge rectifier is operated condenser input, the available DC current is approximately 1/3 the normal DC current. By proper application of these values, many plate transformers can be used to obtain different voltage outputs without harmful results. This chart should be kept handy by every amateur. Due to the economical size of bridge rectifiers which permit high voltage output with inexpensive receiver type tubes, bridge rectifiers are becoming more and more popular. With care, present transformers can be properly applied to this service. Those who attempt to obtain the same DC load current from a bridge rectifier as from a full wave rectifier will in many cases find themselves in the same position as Joe Ham, with a burned out transformer on their hands.

I hope this article serves as an explanation to those who have already gone through this sad experience.

## RADIO REPAIR MEN—AMATEURS

Sears, Roebuck and Co.,  
The World's Largest Mail Order  
Company (in the Radio and Parts  
business for almost 20 years) announce  
for restricted distribution a new  
Radio Parts and Amateur  
Equipment Catalog.

### 24-HOUR SERVICE

Everything carried in stock—the  
broadest guarantee ever written—  
Complete satisfaction or your money  
refunded.

Write today for catalog No. 63 R 61.  
We will put your name on our mailing  
list and send you this big, new  
catalog as soon as it is off the press.

**SEARS, ROEBUCK and CO.**  
CHICAGO, ILL.

\$1 Brings You the Next 4 Issues of "RADIO"

*We Can Supply all  
Products made by  
The NATIONAL Co.  
at 40% Discount*

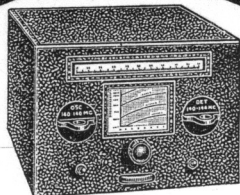

## NATIONAL FB-7A

This seven-tube (Plus rectifier) superhet S.W. receiver has been designed for the experienced amateur and is known the world over for its wonderful performance. It incorporates every latest feature including full vision dial, front panel plug-in coils, send and receive switch, heat oscillator switch, calibration chart, etc. **PN13867—FB-7A Receiver**, with air Dielectric Condensers in IF Amplifier, completely wired, less coils and tubes. List price **\$37.50** \$62.50—Your cost

**PN13874—Complete kit of RCA tubes, \$4.70**  
1-56, 1-57, 2-58's, 2-24's—your cost

## Cathode Ray Oscillator

Offers a means of checking both phone and C.W. transmitters by providing an instantaneous graphic picture of actual operating conditions in transmitter circuits . . . unobtainable by other means. Indicates Percentage Modulation, Signal Distortion and Peak Voltages. Unit entirely self contained. List price less tubes, \$29.50—

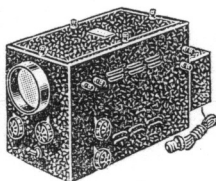

your cost, **PXN13832 \$17.70**

RCA type 906 Cathode Ray tube with 3-in. screen. Net price **\$18.00**

## other NATIONAL Products

**NATIONAL "HR06-9-tube Super-Het Amateur Receiver** complete with coils, less tubes, speaker and power supply. **PXN13771**, your cost **\$139.80**

**NATIONAL "SW-3"—for DC operation**, less tubes, coils and power supply. List price \$32.50. **PXN13819**, your cost **\$19.50**

**POWER SUPPLY for "SW-3"** less tube. List price \$26.50. **PXN13809**, your cost **\$15.90**

## All Nationally Known Lines

We also carry the following nationally-known lines in stock at all times: Cardwell, Hammarlund, United Transformer, Weston, Triplet, Allen-Bradley, Cornell-Dubilier, Sangamo, Pyrex, Signal and many others. Let us quote you on your requirements first!

# Here is a Medium Powered TRANSMITTER You Can Afford to Own!



## Lafayette 30-Watt Type P-46 TRANSMITTER

For those Hams who cannot afford a 100-watt job (similar to the Lafayette described in "RADIO", October 1934 issue) Lafayette announces this new 30-watt, type P-46 X'mitter which is completely self contained including power supply and which therefore will operate wherever 110 V. 50-60 cycle current is available.

The circuit employed in this transmitter is the now very popular "Les-tet" Oscillator Buffer or Doubler with a pair of 46's in parallel operated as a Class "C" Amplifier.

The complete unit is assembled on a standard 8¾-in. Rack Panel and therefore can be readily used to replace any obsolete Driver for an amplifier requiring 30 watts or less for excitation. Plug-in coils are available for all amateur bands from 20-160 M., one set being supplied with the transmitter.

It is available in a metal crystalline finish cabinet as illustrated, making a completely self-contained 30 watt C. W. X'mitter or less cabinet as a rack panel unit. A separate speech amplifier modulator is available for the above X'mitter which will modulate it 100% with 60 watts input. Its output is 30 watts absolutely undistorted with an overall gain of 110 DB. Its frequency response is flat within +1.5 DB between 60-17,000 cycles! The modulator has been designed for use with a crystal microphone.

**PXP15947**, your cost complete with 1 set of coils but less tubes **\$49.50**

and cabinet **\$49.50**

Cabinet as illustrated, your cost, **PXP15254 \$4.50**

## Hard to Get Parts That Will Make a PROFESSIONAL job of your Equipment

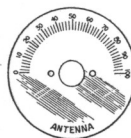

### DIALS

4-in. highly polished nickel silver scales, etched figures. 1½-in. intg. centers. Marked: Amplifier Plate, Amplifier Grid, Oscillator, Antenna, Buffer. No. **60¢**

2¾-in. Diam. same as above but marked; NEUTRALIZATION also Blank. No. **50¢**

2¾-in. Diam. with Aluminum figures on black. Marked: Tone, Volume, Mixer gain, Button Current, **PXH9859**, Ea. **10¢**  
—Be sure to specify markings wanted—

### INDICATOR PLATES



Rectangular aluminum plates, 1½x¾-in. Black background, aluminum figures. Marked: Filament—1st On—2nd Off; Plate—2nd On—1st Off; Oscillator Plate Current; Amplifier Grid Current; Buffer Plate Current; Amplifier Plate Input; Amplifier Screen Current; Antenna Feeder Circuit; Output Grd-Grid. No. **PXH9898**. **10¢**



### INDICATOR KNOBS

Black bakelite 2¾-in. diam. for ¼-in. shafts. **PXH9895**, each **22¢**  
Black bakelite 1½-in. diam. for ¼-in. shafts **AH9896** ea. **17¢**

### POINTER KNOBS

Black bakelite. Fine for test equipment, transceivers, etc. ¼-in. shaft with set screw. White engraved line. **PXM13055** 2¼-in. **10¢**  
long, each  
**PXM13054** 1¼-in. **09¢**  
long, each

### GENERAL UTILITY CABINETS

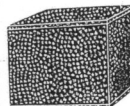

Black Crystalline finish. For X'mitting units. Receivers, mixers, input stages, etc. Four standard sizes:  
**PXY22174** 5½x 6x 5½, each **69¢**  
**PXY22175** 5 x 9x 6, each **99¢**  
**PXY22176** 8 x 10x 10, each **\$1.19**  
**PXY22177** 11 x 12x 8, each **\$1.69**



### CIRCULAR PLATES

Black background, aluminum figures 1-in. diam., ½-in. hole. Marked: Mike-Phone, Cell Disc; Adjust-Cell Voltage; On-Off. **PXH9899**, each **10¢**

### INDICATOR PLATE

Black background, aluminum figures, marked CW-Phone Switch. **PXH9918**, each **15¢**

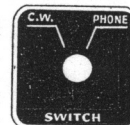

# WHOLESALE RADIO SERVICE CO.

NEW YORK, N.Y. - 100 Sixth Avenue

ATLANTA, GA. 430 W. Peachtree St.

NEWARK, N.J. 219 Central Ave.

WHOLESALE RADIO SERVICE COMPANY,  
100 Sixth Avenue, Dept. P-25,  
New York, N. Y.

Send me the order I have described in enclosed letter.  
 Send me your new 32-page BARGAIN BOOK 56-B.

Name \_\_\_\_\_  
Address \_\_\_\_\_  
City \_\_\_\_\_ State \_\_\_\_\_

# CROWE CABINETS and DIALS

For 5 Meter Transceivers, Short Wave Sets, Monitors, Preselectors, Frequency Meters, Small Portable Transmitters, Test Equipment, and many other uses.

Give your set that finished appearance and necessary protection with a sturdy CROWE cabinet, finished in Crystal-line for permanence and equipped with CROWE tuning control for short wave and other fine tuning.

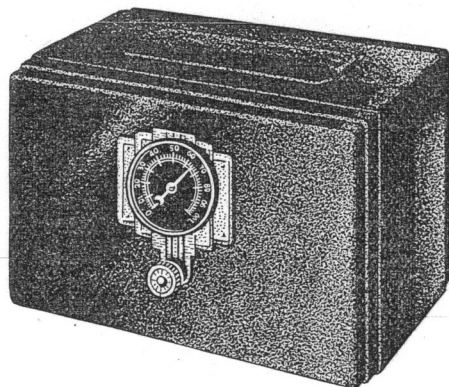

No. 245 Cabinet for Small 5 Meter Sets

We carry in stock a complete line of name plates, dials, scales, etc., for transmitter panels. Send today for literature illustrating and describing our new material for Amateurs, Experimenters and Set Builders.

Export orders receive special attention, Cable Address—CROWNAME CHICAGO.

## CROWE NAME PLATE & MFG. CO.

1755 GRACE STREET

Established 35 Years

CHICAGO, ILL., U. S. A.

Pacific Coast Representative—W. BERT KNIGHT, INC.

## Old-Timers Organize

THE farewell banquet tendered Bernard H. Linden, who for many years was Radio Inspector in charge of the San Francisco office and who has been transferred to a similar position at Los Angeles, was the means for organizing "RADIO'S OLD-TIMERS." This new organization will meet but once each year, on the 25th of January. Seventy of San Francisco's old-timers pledged charter membership and a committee of three was appointed to make the necessary arrangements for an annual round-up. On the committee are Ralph Brunton, owner of KJBS broadcasting station; Ralph M. Heintz, president of Heintz & Kaufman, Ltd., and H. W. Dickow, publisher of "RADIO". The radio careers of each of these three committeemen dates back to 1906.

The organization will function along the lines of the well-known "Last Man's Club". It is hoped that similar organizations will be established in other cities so that a national society can be formed. Those whose radio experiences date back to the beginning of radio broadcasting are eligible to membership. Communications can be addressed to the publisher of "RADIO".

## New 12-Page Catalogue Published By Hammarlund

OVER one hundred and twenty exclusive items are described in detail in the new 1935 12-page catalogue just released by the Hammarlund Manufacturing Company, Inc., 424 West 33rd St., New York City.

Among the many new units included are the low loss XP-53 coil forms and short wave coil kits; midjet type replacement intermediate transformers for 175 and 465 KC; midjet type isolantite based equalizing condensers; midjet isolantite based air padding condensers, and isolantite trimmers for midjet intermediate transformers. The midjet condenser group has also been extended to include both midline and straight line capacity types. This applies to the singles and duals, including the double spaced types. The ever popular transmitting condensers and radio frequency chokes are also catalogued, as well as the four other well known chokes, large and small.

Described also are the isolantite short wave coil forms for short wave and ultra short wave work, sockets, flexible couplings, triple grid tube shields, air tuned and standard intermediate transformers, star midjet condensers, standard equalizers, standard isolantite base trimmers and bakelite base trimmers.

The standard and crystal model "Pro" and the 1935 edition of the short wave manual are also shown and described in this interesting book.



## DEPENDABLE S.W. PARTS

### MIDGET CONDENSERS

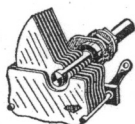

Built with watch like precision. Rugged in construction. Note the four points of superiority.

1. Isolantite Insulation
2. Brass Plate Assemblies
3. Soldered Assemblies
4. Mid-line tuning

Cat. No.	Cap. MMFD.	Plates	Price \$
323	20	3	.85
322	35	5	1.00
148	50	7	1.10
901	80	11	1.15
321	100	14	1.25
396	140	19	1.45
320	150	21	1.50

### BUD SOCKET HOUSING



Is designed especially for front panel mounting of tubes on Transmitters, Scientific Instruments, Sound Amplifiers, etc. With this unit you have easy access to the tubes. Made of cast Aluminum, very rugged in construction. Finished in Baked Krinkle Enamel. 3 mounting screws hold housing securely

to panel. Height 1-5/16", width 3", depth 3/8". Socket hole 1 3/8" diameter. Socket mounting hole centers 1-11/16".

No. 1121, Price 60c

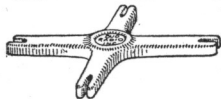

### UNIVERSAL JOINT AERIAL INSULATOR

Ideal for Zepp or current feed aerial systems. Made of glazed porcelain. Size 10" long x 6" wide. Arms taper toward end. No. 219—Price, 90c

Listed above are but a few of the items in the complete BUD line. Write for New 1935 Catalog! All list prices shown in this advertisement are subject to 40% discount when purchase is made from an authorized BUD jobber. If your jobber cannot supply BUD parts, send your order direct to us together with your jobber's name and we will make shipment direct.

## BUD RADIO, INC.

1937 E. 55th STREET  
CLEVELAND, OHIO

A REAL NEW DEAL FOR  
ALL U. S. A. HAMS!

7.50 TO \$10.00

DOWRY PAYMENTS  
PUTS THESE SETS  
IN YOUR STATION  
10 MONTHS TO PAY BALANCE

McMURDO SILVER 5C  
PATTERSON PR12  
PFANSTIEHL S.S.  
NATIONAL  
HAMMARLUND  
RCA - ACR 136

WRITE • WIRE • CALL • PHONE  
for technical bulletins on these sets and  
dope on our "painless" payment plan

All amateur parts in stock  
WILCOX RADIO SALES  
(W9DDE—W9CRT—W9APY—W9WR)  
506 S. Wabash Avenue Chicago  
WEBster 4101

You can get the next 4 issues of "RADIO" for \$1.00



# QRA

GET THE NEW AMATEUR CALLS twice a month. Keep up to date. If K6LQS, in Honolulu, answers your CQ, go right back at him with his first name. When he asks you how you know it, tell him every new amateur call is listed in "QRA" magazine. This includes all call areas in the United States and in Canada. Mail a dollar-bill for a six-months subscription to "QRA", Allen Publishing Co., Box 187, Waterville, Maine.

"QRA", Allen Publishing Co.  
BOX 187 WATERVILLE, MAINE



Personify Your QSOs  
Send 'em a  
DEL-RAD "Ham-Stamp"  
Mail us your photo and \$1.50 for  
100 Special "Ham-Stamps"  
Your Call Letters Inserted  
DEL. RADIO SALES CO.  
405 S. DEL. AVE. WILM., DEL.

## NEW RADIO CATALOG

Just off the Press! Hundreds of latest developments in Short Wave and 5-Meter parts and accessories. Everything for the Serviceman, Ham, Amateur and Experimenter. Sensational new line of S.W. Receiver Kits from 1 to 5 tubes. RCA-Hazeltine license. Send 10c coin or stamps to partially defray cost of handling and mailing. Get your copy at once.

INSULINE CORP. OF AMERICA  
23-25 Park Place Dept. T-15 New York, N. Y.

## RADIO ENGINEERING

RCA Institutes offers an intensive course of high standard embracing all phases of Radio. Practical training with modern equipment at New York and Chicago schools. Also specialized courses and Home Study Courses under "No obligation" plan. Illustrated catalog on request.



RCA INSTITUTES, INC., Dept. RA-34  
75 Varick St., N. Y. 1154 Merchandise Mart, Chicago  
Recognized Standard in Radio Instruction Since 1909

ASK THE HAM WHO OWNS A COPY!  
**GET YOURS!**

The ••••• Edition

## "WHO'S WHO IN AMATEUR RADIO"

160 Pages

giving photos, personal and station data, on the liveliest bunch of QSO's ever gotten up between two covers.

**50¢ Postpaid**

### ON APPROVAL COUPON

Radio Amateur Publishers  
1107 Broadway, N. Y. C.  
Please send me a copy of the latest edition of "Who's Who." I agree to remit 50c in 5 days or return the "Who's Who" postpaid.

Name ..... Call .....

Address .....

All licensed amateurs are requested to send in personal and station data for the next edition. Give your age, occupation, hobbies; xmtr and recvr data, operating skeds and frequencies, etc. This listing is gratis.

RADIO AMATEUR PUBLISHERS  
1107 BROADWAY NEW YORK CITY

## Problems Encountered When Changing to Phone

(Continued from page 9)

fect in every respect. There should be enough buffer stages between the oscillator and the modulated amplifier so that variations in the plate voltage applied to the modulated amplifier cause no change in the beat note of the carrier, as observed with a good monior. These buffer stages should be perfectly neutralized and the final modulated amplifier should be capable of perfect neutralization. Any feedback in the final amplifier will be reflected in non-linear modulation and will cause audio amplitude distortion of the radiated signal. It should be remembered that a plate modulated Class C amplifier must be biased to about 2.2 times cut-off and should have about 25 per cent more grid excitation than would be required for ordinary CW operation. Most amateur phones give trouble because of lack of sufficient grid excitation on the modulated amplifier. This also causes non-linear modulation. The tubes used in the modulated amplifier must have a reserve of filament emission sufficient to allow the peak plate current to double during 100 per cent modulation; otherwise the linearity will suffer and the life of the tube will be shortened.

If it is intended to use Class B modulators it should be remembered that the load drawn by the modulators from their plate power supply varies with the percentage of modulation so that voltage regulation of the power supply is important. It may be necessary to provide a swinging input choke so that the power supply will have a choke input filter on light loads and a condenser input filter when heavily loaded.

Additional shielding or isolation of the RF portion of the transmitter will often be necessary when going to phone operation as it is essential that all RF be kept out of the speech amplifier in order to eliminate overloading and singing of the audio amplifier. An alternative plan is to use extra-good RF shielding around the speech amplifier equipment. The shielding around the RF portion is less important. It should be remembered that the unwanted coupling between the RF and AF portions of a phone transmitter increase directly with the frequency of operation. In other words, the feedback from a 20-meter transmitter, for a given degree of isolation, is eight times as evident as in a similar 160-meter phone transmitter. Thus about eight times as much shielding and isolation is necessary when operating on 20 meters as on 160 meters. Most of the troubles with RF feedback are caused by poor ground connections. The RF and AF portions of the transmitter should use low resistance SEPARATE grounds. It may be a good idea to provide a ground return for the audio frequency modulating voltage between the RF and AF portions of the transmitter, but an RF choke, properly by-passed for RF, should be placed in this lead to ensure that the RF will find its way home without getting into the many audio frequency circuits on its way. Electricity has a habit of taking, not the shortest path, but EVERY available path it can find. Most of it prefers to take the shortest path, but some of it ferrets out every conceivable passage. If one of these many passages happens to lead through a low-level audio circuit, the trouble begins.

The actual process of modulation is the mixing of audio and radio frequency currents. This occurs usually in the plate circuit of a class C RF amplifier which is plate modulated. The term "Plate Modulation" is not strictly accurate. Power Modulation is a much more desirable term.

(To be continued)

# AMATEUR ALL STANDARD LINES HEADQUARTERS WE SERVE YOU BEST.

SEND FOR THIS CATALOG!  
IT LISTS EVERYTHING FOR SHORTWAVE TRANSMITTING AND RECEIVING

Aerials  
Chokes  
Coils and Forms  
Condensers  
Crystals and Holders  
Dials and Knobs  
Insulators  
Jacks, Plugs  
Keys - Meters  
Monitors



Oscilloscopes  
Power Packs  
Preselectors  
Relays  
Receivers  
Resistors  
Sockets  
Transformers  
Transceivers  
Tubes - Tubing  
Wave Meter

NOW IN STOCK  
THE NEW RCA-ACR 136  
COMMUNICATIONS RECEIVER  
Write for Literature

SEND FOR THE ALLIED CATALOG

## Allied Radio

ALLIED RADIO CORPORATION  
833 W. Jackson Blvd., Chicago, Dept. J.  
 Send me your FREE 1935 Catalog.  
 Send me the RCA-ACR 136 Bulletin.

Name .....

Address .....

City .....

if  
it's a  
matter of  
resistance

Send for  
Ward Leonard  
Circular  
No. 507

The new 1935 Ward Leonard Circular 507 gives you information about Grid Leaks, Bleeder Resistors, Center-Tapped Resistors and a host of other handy items that Ward Leonard manufactures for the amateur enthusiast.

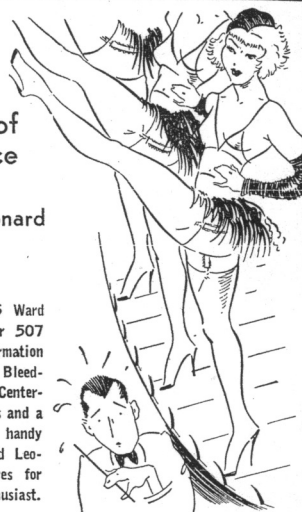

WARD LEONARD ELECTRIC COMPANY  
41 South St., Mount Vernon, N. Y.

Please send me free Circular #507 about W. L. Resistors.

Name .....

Street .....

City and State .....

Call Signal .....

"Quicker than a Short Circuit"

## LITTELFUSES

Instrument Littlefuses, for meters, 1/200 amp. up.  
Hi-Volt Littlefuses for transmitters, etc. 1000, 5000 and 10,000 volt ranges, 1/16 amp. up.  
Neon Voltage Fuses & Indicators (Tattletales) 100, 250, 500, 1,000 & 2,000 volt ratings.  
Aircraft Fuses, Auto Fuses, Fuse Mountings, etc.  
Get new Catalog No. 6  
LITTLEFUSE LABS., 4503 Ravenswood Ave., Chicago, Ill.



## QUALITY and Low Price



Quality first, because transmitting condensers must stand up. But price, too, for mass production serves those 1935 pocketbooks.

Aerovox Oil-impregnated Oil-Filled Transmitting Condensers offer the best value today. Sections of pure linen paper . . . oil impregnated . . . free from mechanical strain and plate flutter . . . real high-tension pillar insulators . . . hermetically sealed in positively leak-proof round or rectangular cans. Just compare these prices on the popular round-can units:

Type 1005—1000 V.				Type 2005—2000 V.			
Cap. mfd.	Size	List Price	Your Price	Cap. mfd.	Size	List Price	Your Price
1	2 x 5 1/8	\$3.20	\$1.92	1	2 x 5 1/8	\$4.75	\$2.85
2	2 x 5 1/8	\$4.25	\$2.55	2	2 1/2 x 5 1/8	\$6.50	\$3.90
4	2 1/2 x 5 1/8	\$6.00	\$3.60				

DATA FREE: New 1935 Catalog covering entire line of Aerovox condensers and resistors. Also sample copy of monthly Research Worker.

# AEROVOX

CORPORATION

84 Washington St. :: Brooklyn, N. Y.

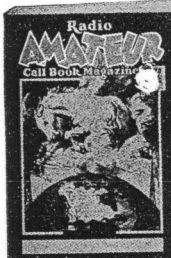

### NEW EDITION Now Ready

The only Radio Call Book published that lists all of the radio amateurs throughout the entire world.

Also a complete list of high frequency commercial stations, International abbreviations and amateur prefixes, "Q, R, & T," systems for reporting signals, New US radio inspection districts, high frequency press, time and weather schedules, and high frequency commercial stations listed by frequencies.

Every ham should have one. Always up-to-date. Single copies \$1.25. Annual subscription \$4.00.  
**RADIO AMATEUR CALL BOOK, INC.,**  
 600 SOUTH DEARBORN ST. CHICAGO, ILL.

RADIO CLUBS are entitled to special group subscription rates to "RADIO." Write for details.



Osockme, Japan,  
December 23, 1934

Big-hearted Editor of "RADIO", Kind Sirs?—

Scratchi are now in the receiver manufacturing business. He have make one thousand and four and a half receivers and all that are now necessary is to find people who will buy such equipment. It give Scratchi gleeful pleasure to help uplift depression times by employing large numbers of radio amateurs to work in Scratchi Factory. But Scratchi find that some such amateur workmen are more dumb than others. Whereupon an open air meeting are called of all employees to give instructions on how to properly build receiving sets. Foreman ask questions from assembled audiences. He ask first, "What are hammer used for?" One amateur mechanic speak up and say, "Hammer used for driving screws into wood". Foreman become much amazed and amused. "Whatinell do you think they put slots in screw heads for?" he inquire. To which ham reply, "Oh, the slots in the screws, why they are used to fit screwdriver blade into when taking screws out". Foreman become gruffled. He tell ham that he thought he kept his brains in his head, but his opinion of location of such brains have dropped to lower level. It then become necessary to demote ham to other department where he can be made more useful. So he are sent into President's office where he are now being used for hat rack. All employees of Scratchi Factory are members of Company Union. It are well known to all here in Japan, that in Unions like in onions there are strength!

Circuit used in Scratchi Receiver are famous well known Silent Circuit, which are most difficult for anyone else to steal from Scratchi because of maze of wires which are put in chassis to fool people. Many of such wires run up and down through into other parts of receiver and seventy wires finally terminate in large metal can which are filled with solid wax. One customer come to factory to inspect Scratchi Receiver and mayhap make purchase of some of same. I show famous chassis to him and he see all such many wires and he say to Scratchi that such contraption are not a receiver, it are a rat's nest.

Last week we hold first public radio show here in Japan. Scratchi have glamorous display at show of my new receiver. It are slapped on back by many prospects and suspects. Scratchi Receiver use twenty-seven tubes. It are constantly on demonstration at show and tuneful music come out from hole in loud speaker. While Scratchi make clever speech to tell audience great value of importance of use of all 27 tubes, one person from audience step up to Scratchi's receiver, lift it upside down, and all tubes except one fall out on floor and break. Receiver with only one tube in it still play as good music as when all 27 tubes are used. So Scratchi are quickly greeted with presence of sheriff who bring big legal plaster with him to stick on Scratchi exhibit and close up Scratchi factory. I are now sitting in county jail again, Hon. Editor, and I implore you to rush funds to me most quickly to bail me out. I make honest promise to you to refund bail money to you with great haste, because I were paying license fee for receiver using 27 tubes and I are now making request for refund of license fee paid for 26 of the 27 tubes which were not connected in circuit in receiver.

I must close in great haste and I make most sincere hope that you will have bail money in my hands before sentence are pronounced by Hon. Judge.

Your incarcerated martyr,  
Hashafisti Scratchi.

### When It's Needed in a Hurry!

Servicemen - Amateurs - Experimenters  
Depend on

**BURSTEIN-APPLEBEE CO.**

America's Liveliest Radio House in  
America's Handiest Shipping.

Point.  
1012-A McGee St.  
Dept. 182  
Kansas City, Mo.

148  
Pages  
Write us if you  
haven't a copy.



The new  
RADIOHM  
offers  
smoother  
attenuation



Not that I'm a softie . . . but with my new shaft of aluminum you can almost "bite" me off with a good pair of pliers . . . in fact a few swipes with a file and I'm down to the required size.

Just another refinement that makes it so much easier to use me in a replacement job. And do I work smooth? . . . Ask thousands of servicemen the world over who always use CENTRALAB RADIOHMS for ALL their jobs. Don't say "Gimme a Volume Control." Specify RADIOHMS the next time you stock up.

Every Radio Service Man should be a member of the Institute of Radio Service Men

# Centralab

Radiohms - Resistors - Suppressors

(Division of)  
GLOBE UNION MFG. CO.  
MILWAUKEE

## QUALITY

at a Price You Can Afford to Pay!

### FRANKLIN Transformers

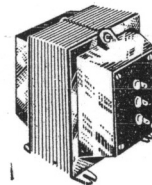

Very conservative ratings on Transformers and Chokes for every Amateur Station.

"MOST SOCK PER DOLLAR"

Write for Catalogs

FRANKLIN TRANSFORMER MFG. CO.  
607-609 22 Ave. N.E., Minneapolis, Minn.

FRANK C.  
**JONES**  
Consulting Engineer

Special High Frequency and Ultra High Frequency Equipment Designed and Developed for Amateur, Military and Commercial Communications.

2037 Durant Ave.

Berkeley, Calif.

FORMS CLOSE ON THE 10th OF MONTH



RATES 10¢ PER WORD PAYABLE IN ADVANCE

**CLASSIFIED RADIOADS**

QSLs, 75c per 100. 2 colors. W9DGH, 1816 5th Ave. North, Minneapolis, Minnesota.

NEW AND USED Weston, Jewell Meters. Bargain prices. All types. Perfect condition. Individually checked. Low prices on meter repairs. Want burned out meters. Free bulletin. W2EDW, Far Rockaway, New York

TRANSFORMERS—1 K.W., 1,500-2,000 each side, \$18.50. 1200 watt 1200-2200-3200 each side, \$24.00. Quotations given. Frank Gerben, W9CES, 2012 S. Peoria St., Chicago, Illinois.

COMPLETE file of "RADIO" year 1934, in heavy leatherette ring binder. \$3.75, postpaid. "RADIO", Pacific Bldg., San Francisco, California.

CRYSTALS—Fully finished and guaranteed X cuts in 1750—3500 kc. bands. Specify frequency desired—\$2.00. Biley BC2 holders—\$1.00 W8DLM, Rochester, Mich.

GUARANTEED CRYSTALS—160-80 meter, X or Y, 1 inch, within two kilocycles, \$2.25. Less than 1 inch, within ten kilocycles, \$1.35. Blanks 60 cents. Odds and ends, five for \$1.00. Oscillating. 85c. Speedy service. William Threm, W8FN, 4021 Davis Ave., Cheviot, Ohio.

STAMP collector hams. Anxious swap common current U.S. used stamps and low denomination mints with foreign collector hams. Write before sending stamps. K. V. R. Lansing, W6QX, 1455 Glenville, Los Angeles.



**SANGAMO**  
Accurate  
Condensers

A quality product for the amateur who wants the best results. Available in 1000, 2500, and 5000 volt construction.

Write for catalog sheet

**SANGAMO ELECTRIC CO.**  
SPRINGFIELD, ILLINOIS

**A-C CURRENT-ANYWHERE!**  
WITH **Kato LIGHT PLANTS**



A little gas and a Kato AC plant enables you to operate AC radios, amplifiers, refrigerators and other standard household appliances. Sizes 300 watts up. Write for interesting descriptive literature on AC and DC models. Prices \$99.00 and up.

Kato Engineering Company, Mankato, Minn., U. S. A.  
AC generators, \$16.00. Converters for operating AC radios from 6, 12, 32 and 110 volts, DC, \$18.00.

**BIRNBACH**  
All-Wave  
**ANTENNA**



IMPROVES reception, strengthens signals, reduces interference and noise on all wavelengths.

Complete kit includes all parts—new-type coupler, requiring no wave-change switch, wire, new-type insulators, accessories and instructions—only \$3.75 list.

Write Dept. PR-2 for FREE data on Antenna Kits, Aerial and Hook-up Wire, Standoff Insulators, etc.

**BIRNBACH RADIO CO., Inc.**  
145 HUDSON STREET NEW YORK CITY



## How Telegraphers Are Made

(Continued from page 24)

finger hitting the paddle. Now there isn't any use talking about that or arguing. There is only one correct way and anybody who thinks differently is nertz. You've got to slap those dashes over just exactly as though you were slapping your mother-in-law . . . with the wrist straight up and down and the index finger and large finger hitting the paddles, with a full arm movement.

Try it! Put that automatic on the desk in front of you where it belongs, about where a letter would be if you were gonna sign it. It'll be somewhere around 12 inches in on the desk directly in front of you. Your arm diagonally across the desk with the fingers resting on the paddle and the elbow just off the desk. And the hand up and down. Keep your wrist off the table. You send with your whole arm.

Do what I'm telling you. Just try it. It won't cost anything. If you could only realize how easy it is to be really good at this code racket, you'd go wild over it.

And now I find that my "inspiration" is exhausted. Oh these phoney false bottom bottles! I'll breathe a little prayer (oh, and is it strong) onto the sheet and yank it outta this mill where I sill have some semblance of control over my fingers. I often wonder how many other fellows thank their lucky stars for a knowledge of touch typing which is so vitally necessary in writing when your eyes become bleared!

More next month.

## LEARN CODE QUICKLY

AND EASILY AT HOME.

THE  
INSTRUCTOGRAPH  
Enables You to Practice  
ANY TIME - ANY WHERE  
ANY SPEED



The most practicable method of learning the code on the market today. Leading schools and the Government use tape machines because there is nothing better.

A SMART INVESTMENT because it is priced low (cash or terms) and built to last indefinitely. Highest quality throughout.

Start now with the aid of an INSTRUCTOGRAPH TO QUICKLY MASTER THE CODE and send intelligently with the best of them.

Can be rented as low as \$2.00 per month (3 mos. or more). A post card will bring full information.

INSTRUCTOGRAPH CO.

915 LAKESIDE PLACE

CHICAGO

OAKLAND, CALIF., 12th AND FALLON STS.



40%—On MOST ALL LINES  
RADIOS - PARTS - APPLIANCES  
NEW CATALOG ready for Western Dealers.

Distributors

ARVIN CAR RADIO

## CANADIANS

Write for wholesale catalogue  
and special bargain list

RADIO TRADE SUPPLY CO., LTD.  
587 YONGE ST. TORONTO

Shhh! Shhh!

**QUIET**

Please!



Individually TESTED  
for NOISE

HERE  
IS THE  
SECRET

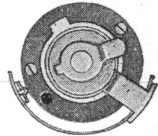

of  
**ELECTRAD'S**  
New QUIET  
**VOLUME CONTROL**

THE resistance element is baked on the flat outer rim of a rigid Bakelite ring. Over this, the special-alloy floating contact gently glides in a straight path.



Resistance element baked on flat outer rim of Bakelite ring

Result: the smoothest, quietest, longest-lived volume control ever devised. Absolute quiet is further guaranteed by INDIVIDUAL TESTING of each control at the factory.

More even distribution of current, smoother control and longer life are attained with this construction. Molded Bakelite case, when mounted, projects only one-half inch behind panel. New type power-switch (approved by underwriters) instantly attachable. Long aluminum shaft—easily cut. All standard replacement values.

175 Varick St., New York, N.Y.

**ELECTRAD**

1935 CATALOG

ELECTRAD, Inc.  
175 Varick St., New York, N. Y.

Please send new 1935 Resistor Catalog . . . Check here for folder on new QUIET Volume Control.

MAIL COUPON FOR

Name . . . . .

Address . . . . .

PR-2

## UNIVERSAL A. C. Humless Power Supply

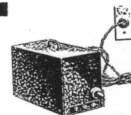

This absolutely silent power unit supplies perfect, pure direct current at 200 v. and 20 mls. direct from any 110 v. 50-60 socket—For use with condenser microphones, photoelectric cell amplifiers, etc. Will also supply both A and B-D.C. current to amplifiers of condenser or other type microphones using No. 230 tubes.

Dealers Net Cash \$23.52

UNIVERSAL MICROPHONE CO., Ltd.  
424 Warren Lane Inglewood, Calif., U. S. A.

\$1 brings you the next four issues of "RADIO"—Subscribe NOW.

# EIMAC 150T

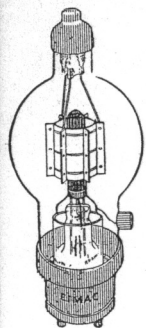

**150 Watts of Available Plate Dissipation . . . .**  
**50 WATTS of Filament Power!**

**CHARACTERISTICS**  
 Fil. Voltage 5V; Fil. Current 10A;  
 Rated Plate Dissipation 150W; Amp. Factor 13; Max. Plate Current 200MA.  
 Plate Voltage 1000-Power Output 150W  
 Plate Voltage 2000-Power Output 300W  
 Plate Voltage 3000-Power Output 450W

## UNSURPASSED in Ruggedness & Performance

A SINGLE EIMAC 150-T, operated as a R. F. Class C Amplifier (75% eff.) will give 150 watts at 1000 volts; 300 watts at 2000 volts; 450 watts at 3000 volts, without exceeding the normal conservative ratings. However, high voltage is NOT essential for satisfactory operation, because the high mutual conductance allows the tube to operate with the maximum of power output and plate efficiency with only 1000 volts on the plate, whereas other tubes of somewhat similar characteristics require at least 2000 to 3000 volts for maximum efficiency. Thus this is the IDEAL tube for BOTH the low-power and the high-power man. It is the only tube the low-power man can buy, yet still utilize effectively when higher power is used. Your first cost is, therefore, your LAST tube cost.

In order to withstand the momentary overloads always associated with amateur operation, the Eimac 150-T maintains its high degree of vacuum even when the tube elements are red hot. This high degree of vacuum is made possible only because TANTALUM is used for grid and plate material, and because no "Getter" is used.

- |   |                          |     |
|---|--------------------------|-----|
|   | Other EIMAC Tube 150-T   |     |
| (1) Has it a hard (NONEX) glass envelope?   | <input type="checkbox"/> | Yes |
| (2) Is it sufficiently gas-free to permit operation at 4,000 volts?   | <input type="checkbox"/> | Yes |
| (3) Have all internal insulators been eliminated to avoid breakdown?  | <input type="checkbox"/> | Yes |
| (4) Has the "Getter" been eliminated in order to prevent release of gas during momentary overloads?   | <input type="checkbox"/> | Yes |
| (5) Are the plate, grid and filament leads separated widely enough for high-voltage, high-frequency operation?                                      | <input type="checkbox"/> | Yes |
| (6) Is the plate-to-grid feed-back capacity less than 3 ufd.s.?   | <input type="checkbox"/> | Yes |
| (7) Can the plate be operated cherry-red without liberation of gas or damage to the tube... in other words, does it have a TANTALUM plate and grid? | <input type="checkbox"/> | Yes |
| (8) Does it use 50-watts or more of filament heating power and have more than 6 amperes of peak filament emission?                                  | <input type="checkbox"/> | Yes |
| (9) Is 200 MA normal plate current conservative for the amount of filament watts utilized?  | <input type="checkbox"/> | Yes |
| (10) Does it use a vertical-bar grid in order to obtain high mutual conductance and ease of driving?  | <input type="checkbox"/> | Yes |
| (11) Is it unconditionally guaranteed for two years to remain gas-free and against break-down of the seals?   | <input type="checkbox"/> | Yes |

Eimac 150T.....\$24.50

## EIMAC 50-T Now \$13.50 Net

### Use Our Engineering Service

Users of EIMAC tubes are given a perpetual Tube Application Engineering Service. Because EIMAC Tubes are designed to do ALL jobs well, there are many applications which cannot be covered in general circulars. EIMAC Tube owners are invited to send their transmitter problems to us. No charge is made for this service.

"COMPARE AND REFLECT"

Order Through Your Dealer

(Some Territory Still Available. Write for Details)

**Eitel-McCullough, Inc.**  
 SAN BRUNO, CALIFORNIA, U. S.

## The Great EIMAC 50-T TRIODE

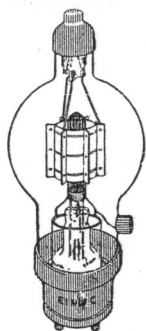

EIMAC 50-T  
\$13.50 Net

● The new Eimac 50-T, little brother to the giant 150-T, is also ready for partial delivery. Only those who actually place deposits with us for this tube will be enabled to secure deliveries. This is the first time that a waiting list has been encountered in the purchase of transmitting tubes. There must be a reason. The verdict is unanimous . . . the Eimac tube is UNSURPASSED.

They are still sitting on our doorstep -- clamoring for this sensational New Tube !!

## and The EIMAC 150-T Triode

ACCLAIMED THE WORLD'S FINEST RADIO TUBE

Place Your Orders With GROSS Today!

DELIVERIES MADE IN ROTATION . . . NO PREFERENCES

● The most amazing tube ever made for the amateur—the tube that cuts your transmitter tube costs in half because its use enables you to "get by" with far less excitation, far lower power input. Fewer stages are required to get highest output. And the tube works as well at 1000 volts as at 3000 or more volts!

● So great has the demand been for this tube that the EIMAC factory is making deliveries in New York to only one distributor . . . GROSS RADIO! Come in and see this new development. Let us tell you all about it. Then place a deposit for one of these tubes. Your order will be filled in rotation. No preference—whether you are a millionaire or work for a living.

● The EIMAC 150-T is already breaking records in amateur stations. Deliveries are being made in rotation as received. Some of the reasons for the instant success of the 150-T are, (1) Oversize Filament, (2) X-ray Vacuum, (3) High Mutual Conductance, (4) Ability to Withstand Momentary Overloads, (5) Lower Excitation Requirements. A typical 1-KW link-coupled tube lineup consists of a 47 oscillator, 45 buffer, EIMAC 50-T buffer and two EIMAC 150-T tubes in the final amplifier, the last two stages operating from a common 2500 volt power supply. Thus it is evident that efficiency and economy work hand in hand only when EIMAC tubes are used.

PRICE . . . . . \$24.50 NET

### GENERAL ELECTRIC PYRANOL COND.

We have been appointed distributors of this famous commercial line of capacitors now for the first time available to the amateur.

	1000 V. D.C.	1500 V. D.C.	2000 V. D.C.
1 mfd. . . . .	\$1.78	\$2.23	\$3.12
2 mfd. . . . .	\$2.67	\$3.71	\$4.75
4 mfd. . . . .	\$4.16	\$5.35	\$6.53

### NICKEL SILVER NAME PLATES

Black background with silver letters and border. Size 1/2" x 1 3/4". Following markings:

Gain	Speech	Doubler
Buffer	Modulator	Class-B
Amplifier	Class C	Filaments
Stand-By	Plates	Grid
Oscillator	Neutralizer	Crystal
Antenna	Antenna	Plate
	10c each	6 for 50c

GROSS CB-70  
 RADIOPHONE-CW TRANSMITTER  
 Output: 75-90 Watts

GROSS CB-100  
 RADIOPHONE-CW TRANSMITTER  
 Output: 130 Watts average

GROSS CW-25  
 CRYSTAL CONTROL TRANSMITTER  
 Output: 25-30 Watts

GROSS CB-25  
 RADIOPHONE-CW TRANSMITTER  
 Output: 25 Watts

Literature and prices on request

### The "EAGLE" Three-Tube Short-Wave Receiver

"Band Spread" over any portion of the tuning range—only finest material used throughout. Employs one '32 R.F., one '32 detector and one '33 Pentode Audio—15 to 200 meters—four coils, supplied. The "EAGLE" is economical—two dry cells will operate the filaments. See March or April 1933 QST for full description of this most excellent value in short-wave receivers.

"Eagle" completely wired and tested, \$11.95. Three tubes tested in your receiver, \$3.00

20% Deposit With All C. O. D. Orders. Remit by M. O. Include Postage. Cable Address: GROSS INC.

GROSS RADIO, INC., 51 Vesey St., New York City, Dept. R

## GREATER DX

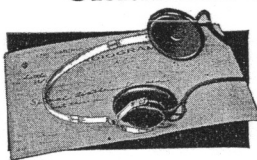

**MORE FUN**  
 from your set with this new sensational TRIMM Headset.

Extremely Light—Automatic Volume Control—High Attenuation of Background Noises—24,000 Ohms Impedance—Finest Quality.

Every "HAM" has been waiting for a Featherweight Headset with all these features. Get yours today and get those distant stations more clearly and easily. There is a difference.

TRIMM RADIO MFG. CO.  
 1528 Armitage Ave. Chicago

## AT LAST



Any Battery Radio Set, whether 2 volt, 6 volt or 32 volt can now be made All Electric, with a Carter Genemotor—the modern "B" Eliminator.

Greater Power—No Current Fluctuation—Minimum Operating Cost—Electrically and Mechanically Guaranteed.

There is a Carter Genemotor for Sound Systems, Two-Way Police Radios, Transmitters, etc.

Write for our latest catalog—it's free.  
**CARTER MOTOR CO.**

365 W. Superior St. Chicago

Radio Dealers and Jobbers who desire to advertise in these columns are invited to write for rates.

# RADIO BUYERS' GUIDE

A Monthly Listing of Reliable Radio Dealers and Jobbers who solicit the patronage of our readers. Buy from your nearest Dealer or Distributor. He is dependable and reliable.

CHICAGO, ILLINOIS

## Chicago Radio Apparatus Company, Inc.

415 South Dearborn Street  
Harrison 2276

Dependable Radio Equipment  
Established 1921

Bulletins on request—we specialize in short wave transmitting and receiving apparatus.  
Catalog Ten cents.

CHICAGO, ILLINOIS

## MID-WEST RADIO MART

520 South State Street  
CHICAGO

Write for Special Catalog—Free

SCHENECTADY, NEW YORK

## ATLANTIC RADIO SUPPLY CO.

712 Broadway

Complete Equipment Stocked for  
Service men—Amateurs—Experimenters

Let us quote you

OAKLAND, CALIFORNIA

## RADIO SUPPLY CO.

2085 BROADWAY.

Hammarlund, Yaxley, Carter, National, Johnson, IRC, Cardwell, Miller, Morrill, Flechteim, Triplett, Haigis Transceivers  
W6GFY

ST. PAUL, MINNESOTA

## LEW BONN COMPANY

2484 University Avenue

Rex L. Munger, W9LIP, Sales Engineer

Radio Wholesaler

Complete Stock

BUFFALO, N. Y.

## DYMAC RADIO

216 E. Genesee St.

CL 2080

Complete Stock Amateur Parts

STANDARD DISCOUNTS

—W8AWK—

LOS ANGELES, CALIFORNIA

## RADIO SUPPLY CO.

912 SO. BROADWAY

The Amateurs'

HEADQUARTERS of the WEST

All Nationally Advertised Parts for Receiving and Transmitting carried in stock at all times.

9 Licensed Amateurs on Our Staff

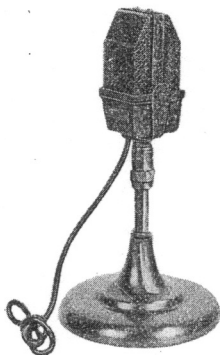
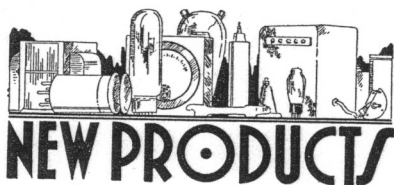

### Amperite Beam Velocity Microphone

PERMITS 8 times more volume than an ordinary Velocity Microphone before it will feed back—and 20 times more than a diaphragm type microphone. In fact it is almost impossible to have feed back with the new Amperite Beam Velocity Microphone, Model RAE-B. Called a Beam Velocity because its angle of pick-up resembles a beam. Although more directional the

sensitivity is the same as to ordinary Velocity, not a damped or close talking microphone.

In most public address installations, the regular Velocity will eliminate acoustic feed back. Rooms with tile walls and similar unusual conditions are met where acoustic feed back is very difficult to handle. For such places, the Beam Velocity Microphone is ideal.

In using the Beam Velocity, it must be remembered that it is very much more directional than the regular Velocity and only to be used in those unusual places where the regular Velocity will feed back.

### New Lafayette Universal Bridge

FOR the benefit of radio service men, amateurs and experimenters who must make accurate measurements of resistance and capacitance values, Wholesale Radio Service Co., Inc., 100 Sixth Ave., New York, N. Y., has brought out the Lafayette Universal Bridge. This is a compact, simplified type of Wheatstone Bridge, and measures resistors from .01 ohm to one million ohms with an accuracy of 1 per cent, and capacitors from .0001 mf. to 100 mf. with an accuracy of 3 per cent.

The whole instrument is only 9 by 4½ by 3 inches, the container being a strong, spot-welded steel box finished in black crackle enamel. There are only two controls on the top panel: a nine-position switch for cutting in different standard resistors and capacitors, and a potentiometer knob travelling over two concentric scales. When the bridge is properly balanced with the aid of an external galvanometer or the output meter in a set analyzer, a direct reading of the value of the unknown unit under test is obtained merely by multiplying the scale reading by the figure opposite the switch setting. A measurement requires only about thirty seconds of time.

Because of the design of the special potentiometer, fractional measurements of resistance, which are important in service work, are made with ease.

The Lafayette Universal Bridge is available in kit form for \$10.95, and in assembled form for \$12.45.

### Back Copies of "RADIO" For Dealer Sales

A VERY limited number of BOUND VOLUMES of all twelve issues of "RADIO" published during 1934 is available for dealer sales. These copies are bound in a heavy, durable loose-leaf ring binder which will give years of service. The retail price of the bound volume is \$3.75. Dealers and jobbers are invited to write for trade prices. This announcement will not be repeated because only a few of these bound volumes are available. Write to "RADIO," Pacific Building, San Francisco, California.

CHICAGO, ILLINOIS

## Chicago Radio Apparatus Company, Inc.

415 South Dearborn Street  
Harrison 2276

Dependable Radio Equipment

Established 1921

Bulletins on request—we specialize in short wave transmitting and receiving apparatus.  
Catalog Ten cents.

BUTLER, MISSOURI

## HENRY RADIO SHOP

Complete stock of Collins, Patterson, National, Hammarlund, Silver, Cornell-Dubilier, Thordarson, Sylvania, Taylor, Cardwell, Triplett, Bliley, Trimm, Johnson, Turner, and others at lowest wholesale prices. Your used apparatus accepted in trade, too. Write for any information.  
211-215 N. MAIN

FRESNO, CALIFORNIA

## PORTS MANUFACTURING CO.

3265 E. Belmont Ave.

Radio W6AVV

National FB7-SW3 and Parts; Hammarlund, Cardwell, Bliley Crystals; Johnson Insulators. Distributors RCA-DeForest Transmitting Tubes  
Established 1914 Send for Wholesale Catalog

SAN FRANCISCO, CALIFORNIA



1452 Market Street.

"The House of a Million Radio Parts"

Hammarlund and National sets and parts.

Sylvania Amateur Transmitting Tubes

Collins Transmitters.

Arcturus Receiving Tubes.

Trimm Phones, all types.

Johnson Antenna Feeders, Insulators,

Transposition Blocks.

SEATTLE, WASHINGTON



## LARGEST PARTS SUPPLY DEPOT IN THE NORTHWEST

Four of Our Employees Are Licensed

W7BRS

Amateurs

W7CR

W7AVC

W7WE

CORNELL DUBILIER, BLILEY, PATTERSON SETS, COLLINS, WARD, LEONARD, UNITED TRANS.

CHICAGO, ILLINOIS

## Newark Electric Company

226 W. Madison St.

Chicago

All Kinds of Equipment for

Service Men - Amateurs - Experimenters  
Write for free catalog

# 6 WORDS THAT MEAN

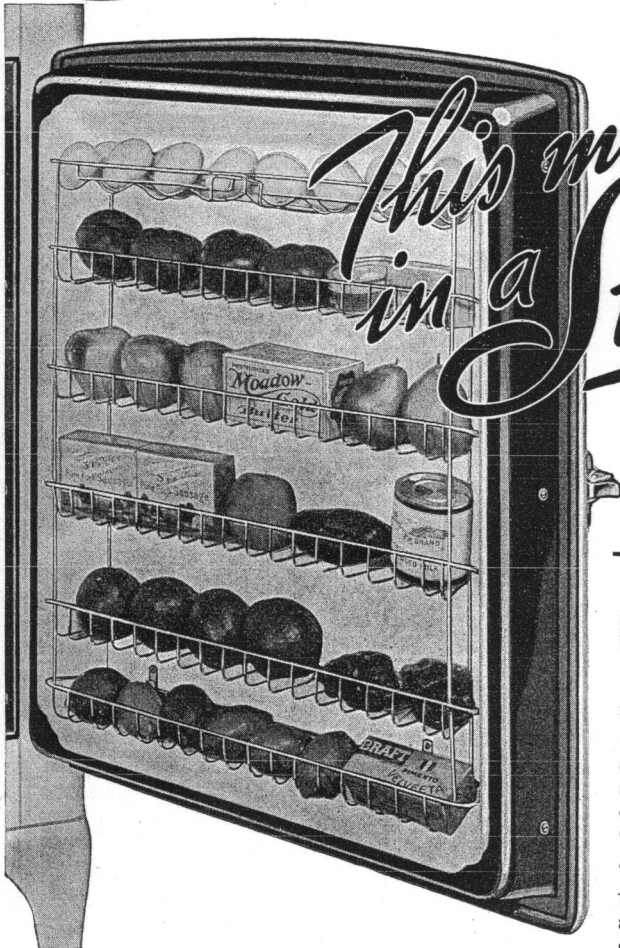

*This much more  
in a Shelvador*

## EXCLUSIVELY IN **CROSLEY** ELECTRIC REFRIGERATORS

**N**INE brand new models—enhanced in beauty, improved in performance where possible. And a new selling slogan—"This much more in a Shelvador!" A slogan that is at once a claim and a demonstration of a definite, tangible advantage that distinguishes the Crosley Shelvador from every other electric refrigerator.

"This much more in a Shelvador"—and twice as easy to find! For the housewife, 50% more "usable" space and half the hunting. For the Crosley dealer, sales, sales, SALES!

During 1934 the Crosley Shelvador was the fastest growing electric refrigerator, in point of sales, in the entire field. And 1935 will be as much greater than 1934 as 1934 was ahead of 1935. Why? Because the Crosley Shelvador is the *one* outstanding feature electric refrigerator on the market. It is way ahead in roominess and convenience, ahead in beauty, ahead in quality, ahead in value. Its advantages are so obvious, so easy to see, that no housewife can fail to realize that if she doesn't get a Crosley Shelvador she doesn't get ALL that electric refrigeration can give her.

Think of the all-purpose utility of the 1935 Crosley Shelvador line: Two table model Shelvadors ranging from 2 to 3 cu. ft. capacity; 4 Shelvador models from 4 to 7 cu. ft.; 3 Tri-Shelvador models from 4.3 to 7 cu. ft. Prices that start as low as \$79.50, delivered. No wonder—you cannot afford NOT to handle Crosley during 1935. Get in touch with your Crosley distributor.

## THE CROSLEY RADIO

*(Pioneer Manufacturer of Radio Receiving Sets)*

### POWERFUL 1935 ADVERTISING CAMPAIGN

Every housewife who reads or hears will know about Shelvador during 1935; for Crosley is inaugurating the biggest, most far-reaching, most commanding advertising campaign in Shelvador history. In many national publications, over the mighty WLW—"the Nation's Station"—the story will be told dramatically, vividly, effectively.

**ALL PRICES INCLUDE DELIVERY..INSTALLATION..ONE YEAR FREE SERVICE**

# BUSINESS

## ...AND 9 BRAND NEW MODELS

*For every purse  
For every family  
For every condition*

### 2 TABLE SHELVADOR MODELS

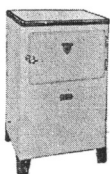

**Table Shelvador FR-20**  
2 cu. ft. NET capacity. 2 ice trays—42 cubes. Semi-hermetic rotary compressor. Dimensions: 36" high, 23 3/4" wide, 25" deep.

**\$79.50**

**Table Shelvador FR-30**  
3.1 cu. ft. NET capacity. 2 ice trays—42 cubes. Rotary compressor. Same dimensions as FR-20.

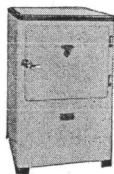

**\$94.50**

#### NEW ROTARY COMPRESSOR

Used on table models. Only 3 moving parts; virtually trouble-free. Semi-hermetically sealed. Uses Theron liquid — non-poisonous, non-inflammable, non-corrosive, odorless.

### 4 SHELVADOR MODELS

ALL CROSLLEY SHELVADOR AND TRI-SHELVADOR MODELS HAVE THESE FEATURES: Automatic interior illumination, ventilated front, no-stop defrosting control, stamped-brass hardware, chromium plated, stainless steel rim around top, white lacquer, porcelain interior.

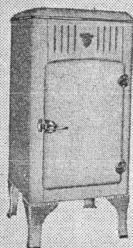

**Shelvador Model FA-40**  
4.09 cu. ft. NET capacity. 3.6 sq. ft. shelf area. 2 ice trays—42 cubes. Dimensions: 52 1/2" high, 23 1/2" wide, 25 1/2" deep.

**\$112.50**

**Shelvador Model FA-50**  
5 cu. ft. NET capacity. 11.3 sq. ft. shelf area. 2 ice trays—42 cubes—one double-depth tray. Dimensions: 56 1/4" high, 25 3/4" wide, 24 1/2" deep.

**\$129.50**

**PFA-50:** Same with porcelain exterior **\$152.00**



**Shelvador Model FA-60**  
6 cu. ft. NET capacity. 13.5 sq. ft. shelf area. 3 ice trays—63 cubes—one double-depth tray. Dimensions: 56 1/4" high, 30 3/4" wide, 25 3/4" deep.

**\$149.50**

**PFA-60:** Same with porcelain exterior **\$174.50**

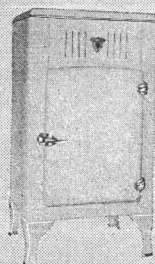

**Shelvador Model FA-70**  
7.08 cu. ft. NET capacity. 14.9 sq. ft. shelf area. 4 ice trays—84 cubes—one double-depth tray. Dimensions: 57 1/2" high, 32 3/4" wide, 25 3/4" deep.

**\$169.50**

**PFA-70:** Same with porcelain exterior **\$194.50**



### 3 TRI-SHELVADOR MODELS

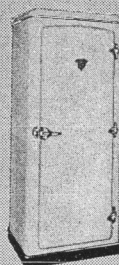

**Tri-Shelvador Model F-43**  
4.3 cu. ft. NET capacity. 9.15 sq. ft. shelf area. 2 ice trays—42 cubes—one double-depth tray. Dimensions: 56 3/4" high, 23 3/4" wide, 23 1/2" deep.

**\$139.50**

**PF-43:** Same with porcelain exterior **\$153.50**

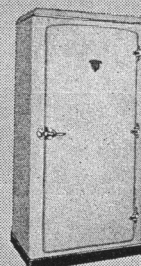

**Tri-Shelvador Model F-55**  
5.51 cu. ft. NET capacity. 11.6 sq. ft. shelf area. 3 ice trays—63 cubes—one double-depth tray. Dimensions: 57 1/4" high, 29" wide, 24 1/4" deep.

**\$164.50**

**PF-55:** Same with porcelain exterior **\$187.00**

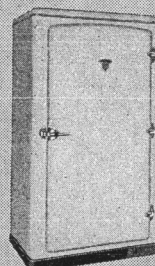

**Tri-Shelvador Model F-70**  
7.08 cu. ft. NET capacity. 14.9 sq. ft. shelf area. 4 ice trays—84 cubes—one double-depth tray. Dimensions: 58 1/2" high, 32 3/4" wide, 25 3/4" deep.

**\$189.50**

**PF-70:** Same with porcelain exterior **\$219.50**

**TRI-SHELVADOR ADDS 3 FEATURES TO THE SHELVADOR**  
The Tri-Shelvador has all the features of the Shelvador and in addition the following:

- 1—SHELvatRAY.** Handy shelf that drops to horizontal position. Place articles on Shelvatray and carry them (Shelvatray and all) to table, range, or cabinet. (Patent pending.)
- 2—SHELvABASKET.** A non-refrigerated basket on bottom of door for greens, carrots, cabbages, and the like. (Patent pending.)
- 3—STORABIN.** Non-refrigerated bin in bottom part of cabinet for reserve bottles, potatoes, onions, and other bulk items. (Patent pending.)

In addition—self-closing stainless steel door to freezing chamber.

Montana, Wyoming, Colorado, New Mexico and west, prices slightly higher.

## CORPORATION • CINCINNATI

POWEL CROSLLEY, Jr., President.



Home of "the Nation's Station"—WLW—500,000 watts—most powerful in the world—70 on your dial.

**ALL PRICES INCLUDE DELIVERY..INSTALLATION..ONE YEAR FREE SERVICE**



# Increase the Fidelity Range of Your Receiver or Amplifier By Using the VARITONE\*

THE VARITONE AUDIO UNIT IS THE ONLY TRANSFORMER OF ITS KIND GIVING CONTINUOUSLY VARIABLE LOW END, HIGH END, OR LOW AND HIGH END EQUALIZATION.

DOES YOUR AMPLIFIER OR SET SOUND

TINNY LIKE THIS?

OR DULL LIKE THIS?

OR LACKING HIGHS AND LOWS LIKE THIS?

● We owe a vote of thanks to our distributors and customers for their patience in waiting for deliveries on the Varitone Units. The first large supply was scooped up in a few days. But we are now caught up and orders will be filled promptly.

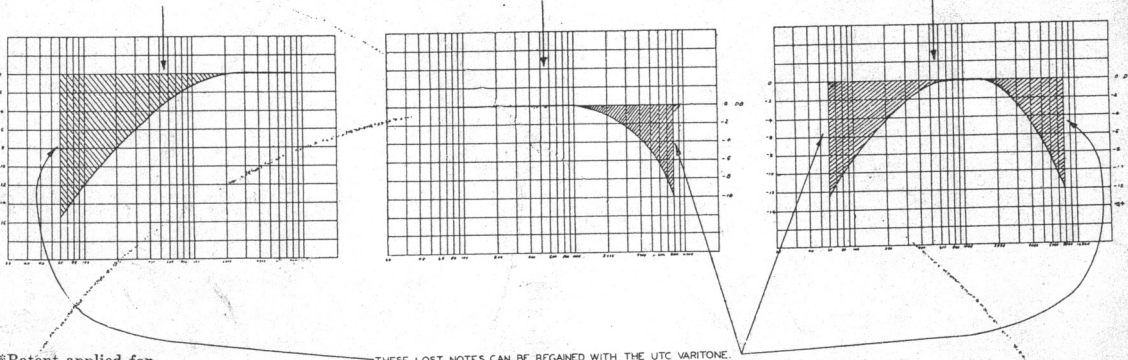

\*Patent applied for

THESE LOST NOTES CAN BE REGAINED WITH THE UTC VARITONE.

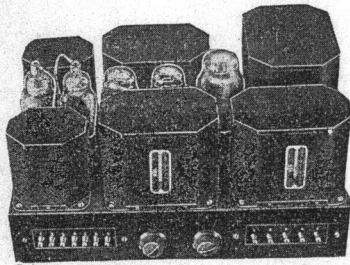

Three stage 45A prime amplifier with VARITONE

VT-1—Designed to work from a single plate or low impedance line-mike to one or two grids. List price \$8.50. Net to dealers \$5.10.

VT-2—Designed for insertion across a 200 ohm or a 500 ohm line or across a 5000 to 20000 ohm plate. List price \$6.00. Net to dealers \$3.60.

The VARITONE is an essential component for High Fidelity theatre and P. A. amplifiers. Manufacturers of such equipment are invited to write us regarding the application of the VARITONE to their equipment.

Affords 15 D B controllable correction of low frequency response, high frequency response or simultaneous correction of low and high frequency response.

Typical Components for use in a popular priced High Fidelity Receiver Amplifier Using the VARITONE as an input source.

	List Price	Net Price
VT-1 Varitone Input Transformer.....	\$8.50	\$5.10
PA-132—from single 57 triode plate to push-pull 45 grids.....	5.00	3.00
PA-245—from two 45 A prime plates to Broadcast and Voice coil lines.....	7.00	4.20
PA-22 —45 A prime plate and filament supply transformer.....	10.00	6.00
PA-40 —A prime input choke.....	4.50	2.70
PA-44 —Output smoothing choke.....	4.50	2.70
	<b>\$39.50</b>	<b>23.70</b>

UTC NIKLSHIELD Audio filter and Power Components are now available in amplifier kits. Quality units that all Hams can afford.

NS-2—1 plate to two grids. Split secondary. 2:1 ratio.....	\$1.50
NS-3—2 plates to two grids, 1.8:1 ratio.....	1.65
NS-2W—1 plate to two grids. Wide range response. 1:1 ratio.....	2.10
NS-21—Push-pull 2A3 plates to 500, 8, 4, 2 ohms.....	2.10
NS-291—single 2A3, 45, 42, 2A5 triode plate to push-pull A prime 2A3, 45, 42, 2A5 grids.....	2.25
NS-292—push-pull 53 or 6A6 triode plates to two or four class B 53 or 6A6 grids.....	2.10
NS-293—push-pull triode 56, 37, 57, 77, 6C6 plates to two or four A prime 45, 2A3, 42, 2A5 grids.....	2.10
NS-294—push-pull 2A3 or 45 plates to two class B 210 or 801 grids.....	3.00
NS-295—push-pull 2A3 or 59 plates to four 46 or 59 class B grids.....	3.00
NS-453—push-pull A prime 45 or 2A3 plates to 5000, 7500, 10,000 ohms.....	3.00
NS-454—Class B 210 plates to 5000, 7500, 10,000 ohms.....	5.10

Net to Hams

\$1.50  
1.65  
2.10  
2.10  
2.25  
2.10  
2.10  
3.00  
3.00  
3.00  
5.10

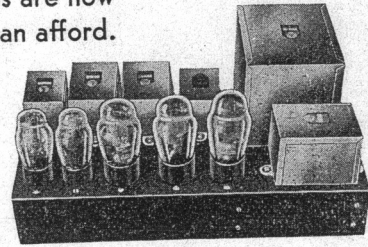

Double push-pull 2A3 amplifier using NIKLSHIELD units

## UNITED TRANSFORMER CORP.

264-266 CANAL STREET

Export Division, 15 Laight St., New York, N. Y.

NEW YORK, N. Y.

Exclusive UTC distributors carrying a complete stock of UTC products.

Goldamer's, Inc.....	610 Huron Road, Cleveland, Ohio
Wholesale Radio Service Co., Inc.....	100 Sixth Ave., New York, N. Y.
Wholesale Radio Service Co., Inc.....	219 Central Ave., Newark, N. J.
Wholesale Radio Service, Inc.....	430 W. Peachtree St. N. W., Atlanta, Ga.
Sun Radio.....	227 Fulton Street, New York, N. Y.
Gross Radio, Inc.....	51 Vesey Street, New York City
Leeds.....	45 Vesey Street, New York City
William Gram.....	1444 Sheridan St., Lansing, Mich.
Mohawk Electric Co.....	1335 State St., Schenectady, N. Y.
Walter Ashe.....	1100 Pine St., St. Louis, Mo.
Radio Shack.....	46 Brattle St., Boston, Mass.
Nutter & Cross.....	990 Milk St., Boston, Mass.
Radio Service Lab. of N. H.....	1008 Elm St., Manchester, New Hampshire
Hatry & Young.....	203 Ann St., Hartford, Conn.

Cameradio Company.....	603 Grant Street, Pittsburgh, Pa.
W. H. Edwards & Co.....	32 Bway, Providence, R. I.
SEATTLE, WASH.—Seattle Radio Supply Inc.....	2319 Second Ave.
Portland Radio Supply Co.....	1300 W. Burnside, Portland, Ore.
Spokane Radio Co., Inc.....	611 First Ave., Spokane, Wash.
San Francisco Radio Exchange.....	1284 Market St., San Francisco, Calif.

### SOUTHERN CALIFORNIA

Pacific Radio Exchange Inc.....	729 S. Main St., Los Angeles
Radio Supply Co.....	912-14 S. Broadway, Los Angeles
Coast Electric Co.....	744 G. St., San Diego
Prest & Dean Radio Co.....	400 American Avenue, Long Beach
Radio Television Supply Co.....	1701 S. Grand Ave., Los Angeles, Calif.
Radio Specialties Co.....	1816 West 8th St., Los Angeles, Calif.